

# CLOVIS UNIFIED SCHOOL DISTRICT

**BID PACKAGE FOR BID NUMBER 2848**

**Paving at Various Sites**

Eimear O'Farrell Ed.D.  
Superintendent

Clovis Unified School District  
1450 Herndon Avenue  
Clovis, California 93611  
(559) 327-9475

**CLOVIS UNIFIED SCHOOL DISTRICT**

**BIDDING PACKAGE TABLE OF CONTENTS**

DESCRIPTION

Notice To Contractors

Instructions To Bidders

Insurance Submittal Form

Declaration of Good Faith Efforts to Use Disable Veteran Business Enterprises

Bid Proposal Form (including Addenda)

Cost Analysis Form (if applicable)

Bid Bond Form

Student Safety Declaration

Noncollusion Affidavit

Health Screening Form

List of Sub-Contractors

Job References

Specifications

Sample Agreement

General Conditions

Payment and Performance Bonds

## **NOTICE TO CONTRACTORS**

Notice is hereby given that Clovis Unified School District (hereinafter referred to as "Owner") will receive sealed bids prior to the date and time stated for the Bid Opening for:

### **Bid 2848 – Paving at Various Sites**

**Bid Package is available for download at no cost from the District Website at:**  
**<https://www.cusd.com/bidschedule.aspx>**

**If documents are downloaded from the District Website, you must notify Sara Malone at [saramalone@cusd.com](mailto:saramalone@cusd.com) to ensure you receive any future addendum notifications/documents.**

Time of completion date for the project(s) shall be **75 Calendar Days**.

Bids will be sealed and filed in the Business Office of the Owner  
**CLOVIS UNIFIED SCHOOL DISTRICT  
PURCHASING DEPARTMENT  
1450 HERNDON AVENUE  
CLOVIS, CALIFORNIA 93611**

On or before **2:00 PM on March 23, 2021**.

Bids must be accompanied by a bidder's bond, cashier's check, or certified check for at least ten percent (10%) of the amount of the base bid and made payable to the Owner. If a bid bond is used, it must be issued by an Admitted Surety (an insurance organization authorized by the Insurance Commissioner to transact surety insurance in the State of California during this calendar year), which shall be given as a guarantee that the bidder will enter into a contract if awarded the work and will be declared forfeited, paid to, or retained by the Owner as liquidated damages if the bidder refuses or neglects to enter into the contract provided by the Owner after being requested to do so.

**Mandatory job walk is scheduled for Tuesday, March 16, 2021 at 9:00 a.m. at Clovis West High School, 1070 E. Teague, Fresno, CA 93720. Meet at flagpole. The job walk will then proceed to various District locations. Potential bidders must sign in at each site. Please practice social distancing.**

The Contractor shall be required to satisfy the conditions set forth in the contract and Education Code section 45125.2 regarding fingerprinting requirements and student safety prior to permitting any contact with students. Upon award of the contract and before beginning work, the Contractor shall be required to provide a verification of compliance with the student safety provisions of the contract and Education Code section 45125.2.

Upon award of the bid, require signature on the enclosed declaration to ensure compliance with the general Conditions and the Education Code.

The successful bidder will be required to furnish a Payment (Labor and Material) Bond in the amount of one hundred per cent (100%) of the contract price, and a Faithful Performance Bond in the amount of one hundred per cent (100%) of the contract price, said bonds to be secured from an Admitted Surety (an insurance organization authorized by the Insurance Commissioner to transact business of insurance in the State of California during this calendar year), and satisfactory to the Owner. The bidder will be required to give satisfactory proof to the Owner of the maintenance of Public Liability Insurance in the amount of not less than \$2,000,000.00 for more than one person injured in one accident, and the maintenance of property damage insurance in an amount not less than \$2,000,000.00.

The successful bidder will be allowed to substitute securities or establish an escrow in lieu of retainage, pursuant to Public Contract Code Section 22300, and as described in the General Conditions.

The Owner will not consider or accept any bids from contractors who are not licensed to do business in the State of California, in accordance with the California Public Contract Code, providing for the licensing of contractors. In accordance with Section 3300 of said Code, the Contractor shall have a **Class "A" or "C-12" license**

In accordance with Public Contract Code 20111.6, Notice is hereby given that the Clovis Unified School District has determined Bidders performing as both a Prime Contractor and General Contractor (A or B license), or an Electrical, Mechanical, and Plumbing Contractor utilized as a Prime Contractor or Subcontractor must be prequalified prior to bidding on this project. For purposes of this prequalification, Electrical, Mechanical, and Plumbing contractors are contractors holding either a C-4, C-7, C-10, C-16, C-20, C-34, C-36, C-38, C-42, C-43, and C-46 California State Contractors license. Prequalification Applications may be obtained from Clovis USD Purchasing Web Site: <https://www.cusd.com/Pre-Qualification.aspx>. Questionnaire and Financial Statement shall be submitted online to Clovis Unified School District **prior to 5:00 pm, March 15, 2021.**

Pursuant to Labor Code sections 1725.5 and 1771.1, all contractors and subcontractors that wish to bid on, be listed in a bid proposal, or enter into a contract to perform public work must be registered with the Department of Industrial Relations. No bid will be accepted nor any contract entered into without proof of the contractor's and subcontractors' current registration with the Department of Industrial Relations to perform public work. If awarded a Contract, the Bidder and its subcontractors, of any tier, shall maintain active registration with the Department of Industrial Relations for the duration of the Project.

This Project is subject to compliance monitoring and enforcement by the Department of Industrial Relations. In bidding on this project, it shall be the Bidder's sole responsibility to evaluate and include the cost of complying with all labor compliance requirements under this contract and applicable law in its bid.

The lowest bid shall be determined as follows: The lowest total of the bid on the base contract and the bids on all additive items and all deductive items. (Public Contract Code section 20103.8, subd. (b)). The District reserves the right to add or deduct any of the additive or deductive items from the project or contract after the lowest responsible and responsive bidder is determined.

The Director of the Department of Industrial Relations of the State of California, in the manner provided by law, has ascertained the general prevailing rate of per diem wages and rate for legal holidays and overtime work as set forth in Article VIII of the Agreement. The Contractor must pay for any labor therein described or classified in an amount not less than the rates specified. Copies of the required rates are on file at the Owner's business office and are available to any interest party on request.

The Owner reserves the right to waive any irregularity and to reject any or all bids.

Unless otherwise required by law, no bidder may withdraw its bid for a period of sixty (60) days after date set for the opening thereof.

Advertise: **March 5, 2021** and  
**March 12, 2021**

Clovis Unified School District  
Michael Johnston  
Associate Superintendent

**END OF SECTION**

## INSTRUCTIONS TO BIDDERS

### **SECURING DOCUMENTS:**

**Bid Package is available for download at no cost from the District Website at:  
<https://www.cusd.com/bidschedule.aspx>**

**If documents are downloaded from the District Website, you must notify Sara Malone at [saramalone@cusd.com](mailto:saramalone@cusd.com) to ensure you receive any future addendum notifications/documents.**

**Mandatory job walk is scheduled for Tuesday, March 16, 2021 at 9:00 a.m. at Clovis West High School, 1070 E. Teague, Fresno, CA 93720. Meet at flagpole. The job walk will then proceed to various district locations. Potential bidders must sign in at each site. Please practice social distancing.**

### **PROPOSALS:**

Proposals to receive consideration shall be made in accordance with the following instructions:

1. Proposals shall be made on a form therefor, obtained from the Architect or Owner. Bids not made on the proper form shall be disregarded. Numbers must be stated in words and figures, and the signatures of all individuals must be in longhand. The completed form should be without interlineation, alterations, or erasures.
2. No proposal will be considered which makes exceptions, changes, or in any manner makes reservations to the terms of the drawings or specifications, except that explanations or alternate proposals may be made on a separate sheet attached to the bid form. They will not, however, be considered in determining low bid.
3. Questions regarding documents, discrepancies, omissions, or doubt as to meanings shall be referred immediately to the Architect who will send written instructions clarifying such questions to each bidder.
4. Each bid must give the full business address of the bidder, and the name of each person signing shall also be typed or printed below the signature. Bids by individuals must be signed by the individual. Bids by partnerships must furnish the full names of all partners and must be signed in the partnership name by one of the partners, or by an authorized representative, followed by the signature and designation of the person signing. Bid by corporations must be signed with the legal name of the corporation, followed by the name of the state of incorporation and by the signature and designation of the president, secretary, or other person authorized to bind the corporation in the matter. Satisfactory evidence of the authority of the officer signing on behalf of a corporation shall be attached.
5. Pursuant to the provisions of Sections 4100 to 4114, inclusive, of the Public Contract Code of the State of California, which are hereby incorporated and made a part hereof, every bidder shall set forth in its bid:
  - A. The name and location of the place of business of each subcontractor who will perform work or labor or render service to the bidder in or about the construction of the work or improvement, or a subcontractor licensed by the State of California who, under subcontract to the bidder, specially fabricates

and installs a portion of the work or improvement according to detailed drawings contained in the plans and specifications, in an amount in excess of one-half (1/2) of one percent (1%) of the bidder's total bid.

- B. The portion of the work which will be done by each such subcontractor. If the bidder fails to specify a subcontractor for any portion of the work to be performed under the contract in excess of one-half (1/2) of one percent (1%) of the bidder's total bid, the bidder agrees to perform that portion itself. The successful bidder shall not, without the consent of the Owner:
- 1) Substitute any person as subcontractor in place of the subcontractor designated in the original bid.
  - 2) Permit any subcontract to be assigned or transferred or allow it to be performed by anyone other than the original subcontractor listed in the bid.
  - 3) Sublet or subcontract any portion of the work in excess of one-half (1/2) of one percent (1%) of the total bid as to which the original bid did not designate a subcontractor.
6. The Director of the Department of Industrial Relations of the State of California, in the manner provided by law, has ascertained the general prevailing rate of per diem wages and rate for legal holidays and overtime work as set forth in Article IX of the Agreement. The Contractor must pay for any labor therein described or classified in an amount not less than the rates specified. Copies of the required rates are on file at the Owner's business office and are available to any interested party on request.
7. All proposals must be accompanied by a completed Noncollusion Declaration. The bidder must certify that the Bid is genuine and is not sham or collusive, or made in the interest of or on behalf of any bidder not named in the bid, and that the bidder has not directly or indirectly induced or solicited any other bidder to put in a sham bid, or any other possible bidder to refrain from bidding, and that the bidder has not in any manner sought by collusion to secure for itself an advantage over any other bidder.
8. Proposals must be accompanied by a certified check, cashier's check, or bidder's bond, for an amount not less than ten percent (10%) of the amount of the base bid, made payable to the order of the Owner. If a bidder's bond accompanies the proposal, said bond shall be secured by an Admitted Surety (an insurance organization authorized by the Insurance Commissioner to transact business of insurance in the State of California during this calendar year) and satisfactory to the Owner. Said check or bond shall be given as a guarantee that the bidder will enter into the contract if awarded the work, and in case of refusal or failure to enter into said contract, the check or bond, as the case may be, shall be payable to the Owner and retained as liquidated damages.
9. Proposals shall be sealed and filed as indicated in the Notice to Contractors. Note regarding facsimiles: EXCEPT FOR BID SECURITY, all submitted before the bid opening documents may be in the form of facsimiles which have been sent elsewhere and sealed before filing with the Owner. (Any bidder who uses or attempts to use the Owner's facsimile equipment will be disqualified immediately.) The originals of the faxed documents must be mailed to the Owner, postmarked

the same as the bid opening, via certified mail, return receipt requested, or hand-delivered to the Owner by the close of business on the day of the bid opening.

Facsimiles of the bid security are not acceptable - the original of the check or bond must be submitted before the bid opening.

10. Bidders shall possess a valid California Contractors License as listed in the Notice to Bidders. A General Building Contractors License (A or C-12) shall be acceptable in accordance with the California Business and Professional Code Section 7057, paragraph (b): A general building contractor may take a prime contract or a subcontract for framing or carpentry project. However, a general building contractor shall not take a prime contract for any project involving trades other than framing or carpentry unless the prime contract requires at least two unrelated building trades or crafts other than framing or carpentry, or unless the general building contractor holds the appropriate specialty license or subcontracts with an appropriately licensed specialty contractor to perform the work. Owner reserves the right to reject any bid as nonresponsive if a listed subcontractor is not licensed at the time the bidder's bid is submitted to Owner, whether or not the bidder listed the unlicensed subcontractor inadvertently. Owner reserves the right to reject any bid as nonresponsive if a listed subcontractor is not licensed to perform the work for which it is listed at the time the bidder's bid is submitted to Owner, whether or not the bidder listed the subcontractor for that particular work inadvertently.

#### **WITHDRAWAL OF PROPOSALS:**

Proposals may be withdrawn by the bidder prior to the time fixed for the submittal of bids. A successful bidder shall not be relieved of the bid unless by consent of the Owner or bidder's recourse to Public Contract Code § 5100 et seq.

#### **OPENING OF PROPOSALS:**

Opening of proposals shall be as soon after the hour set as will be possible; opening and declaration to be as set forth in the Notice to Contractors. Any and all bidders will be permitted to attend. The Owner is allowed the number of days set forth in the Notice to Contractors in which to determine low bidder.

#### **EXAMINATION OF CONTRACT DOCUMENTS AND SITE:**

Before submitting a proposal, bidders shall examine the drawings, read the specifications, the form of contract, and other contract documents. They shall visit the site of the proposed work; examine the building, or buildings, if any, and any work that may have been done thereon. They shall fully inform themselves of all conditions, in, at, and about the site, the building or buildings, if any, and any work that may have been done thereon.

#### **FORM OF CONTRACT:**

The form of contract which the successful bidder will be required to execute, if awarded the work, is attached hereto and is made a part hereof.

#### **ADDENDA OR BULLETINS:**

Any addenda or bulletins, issued during the time of bidding, shall form a part of the drawings and specifications loaned to the bidder for the preparation of its proposal, shall

be covered in the proposal, and shall be made a part of the Contract Documents. All addenda or bulletins shall be signed by the Architect and approved by the Division of State Architect.

**AWARD OF CONTRACT:**

Rejection of any or all proposals, to contract work with whomever and in whatever manner, to abandon work entirely, and/or to waive any informality in receiving of bids is reserved as the right of the Owner. Before the contract or contracts are awarded, the Owner may at its sole discretion require from the proposed Contractor on each project further evidence of the reasonable qualifications of such contractor to faithfully, capably, and reasonably perform such proposed contract and may consider such evidence before making its decision on the award of such proposed contract.

The lowest bid shall be determined as follows: The lowest total of the bid on the base contract and the bids on all additive items and all deductive items. The District reserves the right to add or deduct any of the additive or deductive items from the project or contract after the lowest responsible and responsive bidder is determined.

The contract shall be awarded to the lowest and most responsible bidder as interpreted by the Owner and specified herein and shall be entered into by the successful bidder within ten (10) days after being notified by the Owner. Identity of lowest bidder will be determined by adding to or subtracting from the base bid the cost of such alternatives as Owner decides to include in the work and contract. The award, if made, will be made within sixty (60) days after the opening of proposals.

**EXECUTION OF CONTRACT:**

The Contract shall be signed by the successful bidder in as many originals as the Owner deems necessary and returned, together with the contract bonds and insurance certificates, within ten (10) days after the bidder has received notice that the contract has been awarded.

**CONTRACT BONDS:**

Two bonds, as itemized below and in the forms presented in these contract documents, shall be furnished by the successful bidder at the time of entering into the contract and filed with the Owner. They shall be in the form of surety bonds issued by an Admitted Surety (an insurance organization authorized by the Insurance Commissioner to transact business of insurance in the State of California during this calendar year) and satisfactory to the Owner.

**Performance Bond** in the amount of one hundred percent (100%) of the contract sum to insure Owner during construction and for one year after completion against faulty or improper materials or workmanship and to assure Owner of full and prompt performance of the contract.

**Payment Bond** (Labor and Material) in the amount of one hundred percent (100%) of the contract sum in accordance with the laws of the State of California to secure payment of any and all claims for labor and materials used or consumed in performance of this contract.

**DRAWINGS, SPECIFICATIONS AND ADDENDA OR BULLETINS:**



Return by each bidder of all drawings, specifications and addenda or bulletins in an un mutilated condition and without any marks or annotations is demanded within the time limit indicated under **DEPOSIT** in this section.

#### **SUBSTITUTION OF MATERIALS:**

All materials are mentioned as standards. Should a Contractor desire to substitute materials or methods for those specified, the Contractor shall follow the guidelines stated herein, and in accordance with Section 01-640. Each review of a substitution request by the Architect or its consultants will be billed to the Contractor at an hourly rate as indicated in Section 01-640.

Substitutions can be submitted in two ways: (1) Prior to Bid Opening, and (2) After Award of the Contract. Either submittal of substitutions is further described herein and must conform to the requirements indicated.

(1) Prior to Bid Opening: The Contractor must insure that proposed substitutions of materials by the Contractor or its subcontractors are submitted to the Architect's office a minimum of fourteen (14) calendar days prior to the Bid Opening for review and possible approval of any equipment or materials thought to be equal to or better than those specified in the drawings or specifications. An Addendum will be issued seven (7) calendar days prior to Bid Opening including all equipment and materials deemed equivalent to those specified and approved by the Architect. Submittals must include comparative spec-data of that specified equipment or material and the proposed substitution as indicated on the completed "Substitution Request Form" in accordance with Section 01-640. Submittals without this information will be automatically rejected.

(2) After Award of the Contract: In accordance with the provisions of Section 3400 of the California Public Contract Code, the Contractor awarded the Contract will be provided a period of (40) calendar days after the award of the Contract for submission of data substantiating a request for a substitution of "an equal" item or items. Substitution requests must be made as provided in Article 3.11.4 of the General Conditions.

#### **PAYMENTS:**

Payments to the Contractor on account of the contract shall be made in accordance with the terms of the contract.

#### **TAXES:**

The Owner is exempt from payment of Federal Excise Tax on materials. The Owner will furnish exemption certificates to the Contractor to be used to obtain materials ordinarily subject to Federal Excise Tax without payment of the tax. Bidders shall deduct Federal Excise Taxes from their bid prices before submitting bids, so that such taxes will not be included in the Contract Sum.

#### **TIME OF COMPLETION AND LIQUIDATED DAMAGES:**

Time is of the essence in this contract, and the time of completion for this project shall be **75 Calendar Days**.

Should said work not be completed within the time limit as may be extended as herein provided, damages will be sustained by the Owner. It is understood and agreed that it is and will be impracticable or extremely difficult to determine the actual amount of

damages which the Owner will sustain in the event of and by reason of such delay, and it is therefore agreed that the Contractor will pay the Owner the sum of **\$1000.00 Dollars per calendar** for each and every day's delay beyond the time specified as and for liquidated damages; in case the Contractor fails to make such payment, the Owner may deduct the amount thereof from any money due or that may become due the Contractor under the contract. Should such money not be sufficient to cover the agreed liquidated damages, the Owner shall have the right to recover the balance from the Contractor or his sureties.

The Contractor shall be required to satisfy the conditions set forth in the contract and Education Code section 45125.2 regarding fingerprinting requirements and student safety prior to permitting any contact with students. Upon award of the contract and before beginning work, the Contractor shall be required to provide a verification of compliance with the student safety provisions of the contract and Education Code section 45125.2.

Upon award of the bid, require signature on the enclosed declaration to ensure compliance with the general Conditions and the Education Code.

**END OF SECTION**

REV. 3.97 (8.98)

## **CALIFORNIA SENATE BILL 854 (2014) – APPLIES TO THIS BID PROJECT**

Senate Bill 854, signed into law June 20, 2014, became effectively immediately. It established a new public works contractor registration program which will collect fees to fund compliance monitoring and enforcement, determine prevailing wage and public works coverage, and hear enforcement appeals.

All contractors and subcontractors intending to bid or perform work on public works projects will be required to register, and annually renew, online for the program. The cost to register for the program is currently \$400.00 and is non-refundable. This is a DIR fee paid to the State. The District will not register a contractor, nor collect funds.

Contractors or subcontractors submitting bids must be registered by March 1, 2015. The requirement to use only registered contractors and subcontractors on public works projects, greater than \$1,000, applies to all projects awarded on or after April 1, 2015. No bid can be accepted nor any contract or subcontract entered into nor purchase order issued without proof that the contractor or subcontractor is registered.

Public works refers to construction, alteration, demolition, installation, or repair work (including maintenance) done under contract and paid by public funds. For a more detailed explanation of public works projects, refer to California Labor Code 1720 -1720.6.

This memo is being sent to all vendors currently contracted with the District's Plant Operations and/or Construction Department. What are we asking you to do? If the services you are providing the District, or may provide the District in the future, fall under the definition of "public works", please ensure you are registered with the DIR prior to March 1, 2015. Effective immediately, the District will be required to fill out a form alerting the DIR of the services you are providing the District. Detailed information is required to complete this form. If the services you are currently providing the District fall under "public works" you may be asked to provide information needed to complete the DIR form. We ask that you complete this in a timely manner to avoid interruption in the services you are providing.

More information can be found at The Department of Industrial Relations website;  
<http://www.dir.ca.gov/Public-Works/PublicWorks.html>.

**Effective July 1, 2018, Senate Bill 96 (SB96) increased the thresholds for submitting a PWC-100 form to DIR. The \$1,000 threshold was increased to \$25,000 for Construction Project and \$15,000 for Maintenance Projects. Public Contract Code defines Construction and Maintenance. These terms are not defined by the contractor or the district.**

**Please note – Contractors are required to pay prevailing wage on ALL projects exceeding \$1,000 and are subject to DIR audit and public record requests on all work provided for a public agency. Contractors are required to keep certified records on file for all work performed for a public agency.**

**The District may require PWC-100 submittal for amounts lower than those stated in SB96.**

**Clovis Unified School District**

**Bid 2848 – Paving at Various Sites**

Insurance requirements due at time of bid submittal:

- 1) Insurance Requirements – Proof of Carriage of Insurance – requirement has been revised from A+ requirement to A coverage requirement**
- 2) Proof of coverage to be submitted with bid proposal at due date and time established in the bid packet.**

INSURANCE RATING SUBMITALL FORM

**Bid 2848 – Paving at Various Sites**

Attach report of Insurance Rating to this form. Rating Report information to be obtained from A.M. Best Company – [www.ambest.com](http://www.ambest.com)

**This form and needed report MUST be submitted with bid proposal at due date and time established in bid paperwork**

Name of Bidder: \_\_\_\_\_

**PROPOSAL FORM FOR BID 2848**

CLOVIS UNIFIED SCHOOL DISTRICT  
CONFERENCE ROOM  
1450 HERNDON  
CLOVIS, CALIFORNIA 93611

Dear Board Members:

The undersigned doing business under the firm name of -

---

hereby propose and agree to enter into an agreement, to furnish any and all labor, materials, applicable taxes, equipment and services for the completion of work described hereinafter and in the contract documents:

**Paving at Various Sites**

for the sum(s) quoted below.

**Total Bid**

\_\_\_\_\_ Dollars \$ \_\_\_\_\_

If written notice of the acceptance of this bid is mailed, telegraphed, or delivered to the undersigned within sixty (60) days after the date of opening of the bids, or any time thereafter before this bid is withdrawn, the undersigned will, within ten (10) days after the date of such mailing, telegraphing, or delivering of such notice, execute and deliver a contract in the form of agreement present in these contract documents and give Performance and Payment Bonds in accordance with the specifications and bid as accepted.

The undersigned hereby designates as the office to which such notice of acceptance may be mailed, telegraphed, or delivered:

\_\_\_\_\_  
\_\_\_\_\_

Our Public Liability and Property Damage Insurance is placed with:

\_\_\_\_\_  
\_\_\_\_\_

Our Workers' Compensation Insurance is placed with:

\_\_\_\_\_  
\_\_\_\_\_

Circular letters, bulletins, addenda, etc., bound with the specifications or issued during the time of bidding are included in the proposal, and, in completing the contract, they are to become part thereof.

The receipt of the following addenda to the specifications is acknowledged:

Addendum No. \_\_\_\_\_ Date \_\_\_\_\_ Addendum No. \_\_\_\_\_ Date \_\_\_\_\_

Addendum No. \_\_\_\_\_ Date \_\_\_\_\_ Addendum No. \_\_\_\_\_ Date \_\_\_\_\_

Addendum No. \_\_\_\_\_ Date \_\_\_\_\_ Addendum No. \_\_\_\_\_ Date \_\_\_\_\_

This bid may be withdrawn at any time prior to the scheduled time for the opening of bids or any authorized postponement thereof.

NOTE: Each bid must give the full business address of the bidder and be signed by him with his usual signature. Bids by partnerships must furnish the full name of all partners and must be signed by one of the members of the partnership, or by an authorized representative, followed by the signature and designation of the person signing. Bid by corporations must be signed with the legal name of the corporation, followed by the name of the state of incorporation and by the signature and designation of the president, secretary, or other person authorized to bind it in the matter. The name of each person signing shall also be typed or printed below the signature. Satisfactory evidence of the authority of the officer signing on behalf of a corporation shall be furnished.

Dated \_\_\_\_\_, 20\_\_\_\_

Signed

Print or Type Name

Business Address

Phone #

Fax #

License #

Additional Signature Lines if Applicable:

Signed

Print or Type Name

Business Address

Signed

Print or Type Name

Business Address

Signed

Print or Type Name

Business Address

State of Incorporation if Applicable

( ) Evidence of authority to bind corporation is attached.

END OF SECTION  
REV. 10/96.arch 3.97 (8.98)



Do not substitute Bid  
Bond Form

The Bid Bond Form in  
this packet must be  
used.

Failure to use the Bid  
Bond form in this bid  
packet may result in  
rejection of bid.

## BID BOND

KNOW ALL MEN BY THESE PRESENTS that we the undersigned

\_\_\_\_\_ as Principal and

\_\_\_\_\_ as Surety, are hereby held and firmly bound unto the Clovis Unified School District, acting on behalf of the State Allocation Board, State of California, hereinafter called the "Owner", in the sum of

\_\_\_\_\_ Dollars (\$ \_\_\_\_\_) for payment of which sum, well and truly to be made, we hereby jointly and severally find ourselves, our heirs, executors, administrators, successors, and assigns.

The condition of the above obligation is such that whereas the Principal has submitted to the Owner a certain bid, attached hereto and hereby made a part hereof, to enter into a contract in writing for the

### **BID # 2848 Paving at Various Sites**

in strict accordance with the Contract Documents.

NOW, THEREFORE,

- a. If said bid shall be rejected, or, in the alternate;
- b. If said bid shall be accepted and the Principal shall execute and deliver a contract in the form of agreement attached hereto and shall execute and deliver Performance and Payment Bonds in the forms attached hereto (all properly completed in accordance with said bid), and shall in all other respects perform the agreement created by the acceptance of said bid;

Then this obligation shall be void, otherwise the same shall remain in force and effect, it being expressly understood and agreed that the liability of the Surety for any and all default of the Principal hereunder shall be the amount of this obligation as herein stated.

Surety, for value received, hereby stipulates and agrees that no change, extension of time, alteration or addition to the terms of the contract on the call for bids, or to the work to be performed thereunder, or the specifications accompanying the same, shall in anyway affect its obligation under this bond, and it does hereby waive notice of any such change, extension of time, alteration or addition to the terms of said contract or the call for bids, or to the work, or to the specifications.

In the event suit is brought upon this bond by the Owner and judgment is recovered the Surety shall pay all costs incurred by the Owner in such suit, including a reasonable attorney's fee to be fixed by the court.

IN WITNESS WHEREOF, the above-bounden parties have executed this instrument under several seals this \_\_\_\_ day of \_\_\_\_\_, 20\_\_\_\_, the name and corporate party being hereto affixed and these presents duly signed by its undersigned representative, pursuant to authority of its governing body.

In presence of:

(Individual Principal)

(Seal)

\_\_\_\_\_  
(Address)

\_\_\_\_\_  
(Business Address)

\_\_\_\_\_  
(Individual Principal)

(Seal)

\_\_\_\_\_  
(Address)

\_\_\_\_\_  
(Business Address)

Attest:

(Corporate Principal)

(Business Address)

By:

(Affix Corporate Seal)

Attest:

(Corporate Principal)

(Business Address)

By:

(Affix Corporate Seal)

The rate or premium on this bond is

per thousand.

Total amount of premium charged, \$

(The above must be filled in by Corporate Surety)

END OF SECTION

If: 10/97 (8.98)

STUDENT SAFETY DECLARATION  
Construction, Rehabilitation or Repair Contractors  
(Education Code section 45125.2)

I, \_\_\_\_\_, declare as follows:

1. I am a representative of \_\_\_\_\_, and am authorized to make this declaration on its behalf;

2. Pursuant to Education Code section 45125.2, I shall not permit any employee, agent or subcontractor to have more than limited contact with pupils without taking protective steps as set forth in that section and this declaration.

3. I declare that I have taken one or more of the following protective measures pursuant to Education Code section 45125.2:

a. Neither I, my employees, agents nor subcontractors will have more than limited contact with students.

b. I have installed or will install a physical barrier at the worksite such that no employee, agent or subcontractor will have more than limited contact with students.

c. An employee, agent or subcontractor will continually monitor and supervise all employee(s), agent(s) and subcontractor(s) who will have more than limited student contact. I have submitted fingerprints to the Department of Justice for the supervisory employee(s), agent(s) or subcontractor(s). I have received a response from the Department of Justice, and I certify that none of these supervisory employees, agents or subcontractors have been convicted of a felony as defined in Education Code section 45122.1. A list of these supervisors is attached hereto.

I know the above of my own personal knowledge and if called as a witness could competently testify thereto. I declare under penalty of perjury that the foregoing is true and correct and that this declaration was executed on \_\_\_\_\_, \_\_\_\_\_, at \_\_\_\_\_, California.

\_\_\_\_\_  
Name of Contractor

By : \_\_\_\_\_

clovis\FINGERPRINTING.11.1999

**NONCOLLUSION DECLARATION**

I, \_\_\_\_\_, declare that I am  
(Name of Representative) (Title of Representative)  
of \_\_\_\_\_,  
(Business Name of Bidder)

the party making the foregoing bid, that the bid is not made in the interest of, or on behalf of, any undisclosed person, partnership, company, association, organization, or corporation; that the bid is genuine and not collusive or sham; that the bidder has not directly or indirectly induced or solicited any other bidder to put in a false or sham bid, and has not directly or indirectly colluded, conspired, connived, or agreed with any bidder or anyone else to put in a sham bid, or that anyone shall refrain from bidding; that the bidder has not in any manner, directly or indirectly, sought by agreement, communication, or conference with anyone to fix the bid price of the bidder or any other bidder, or to fix any overhead, profit, or cost element of the bid price, or of that of any other bidder, or to secure any advantage against the public body awarding the contract of anyone interested in the proposed contract; that all statements contained in the bid are true; and, further, that the bidder has not, directly or indirectly, submitted his or her bid price or any breakdown thereof, or the contents thereof, or divulged information or data relative thereto, or paid, and will not pay, any fee to any corporation, partnership, company association, organization, bid depository, or to any member or agent thereof to effectuate a collusive or sham bid.

I declare under penalty of perjury under the laws of the State of California that the foregoing is true and correct.

Executed this \_\_\_\_\_ day of \_\_\_\_\_, 20\_\_ at \_\_\_\_\_,  
California.

(Signature of Representative)

**NOTE: A declaration does not have to be notarized.**

END OF SECTION  
10/96 (8.98)

## Health Screening

Contractor shall require each service provider who provides services to Clovis Unified School District to conduct screening and/or testing for symptoms of COVID-19.

Such screening or testing, at a minimum, shall:

- (1) be conducted at least daily and before a service provider renders services to the District; and
- (2) comply with requirements or recommendations by federal, state, and/or local health officials that are in effect at the time the service provider is providing services to the District.
- (3) The screening may be in the form of the COVID-19 Service Provider Screening Tool included in this packet, which the District may modify to reflect developing requirements or recommendations from federal, state, and/or local health officials. If any service provider tests positive on any indicators of the self-screening tool, he/she must contact the contractor's assigner and remove himself/herself from service until he/she has no positive indicators on the self-screening or he/she has tested negative for COVID-19. It is the responsibility of the contractor's assigner to replace that service provider with a new service provider, who has no positive indicators on the self-screening tool or has tested negative for COVID-19. Contractor shall also require each service provider who provides services to the District to wear face coverings and/or other personal protective equipment as required or recommended by federal, state, and/or local health officials. In the event that the requirements or recommendations of federal, state, and local health official's conflict, contractor shall require each service provider to comply with the requirement/recommendation that is stricter. Contractor shall not allow any service provider who has tested positive for COVID-19, has symptoms of COVID19, or has any positive indicators on the self-screening tool to provide services for the District
- (4) If service provider has no fever or respiratory symptoms, they can provide service AFTER washing their hands and need to follow social distancing as appropriate for service being provided
- (5) Masking with cloth mask and physical distancing (6 feet apart) is required when providing service in district, especially when around district students and staff.

## FORM WITH BID RESPONSE COVID-19 SERVICE PROVIDER SCREEN TOOL

All contractor service providers are required to “self certify” by answering the questions below prior to entering their assigned Clovis Unified School District service location and coming into contact with students and staff.

1. Feeling fever/chills, body aches, headache, repeated shaking/tremors, fatigue, nausea, vomiting, or diarrhea?	YES or NO	If yes → go home
2. New or worsening respiratory symptoms? (Shortness of breath, cough, congestion/runny nose, sore throat, or new loss of taste or smell)	YES or NO	If yes → go home
3. Has anyone in your household been confirmed or have you had close contact with anyone diagnosed with COVID-19 in the past 14 days?	YES or NO	If yes → go home
<b>If you answer "yes" to any of the questions, you <u>must</u> report possible COVID symptoms to your supervisor to comply with Health Department contact tracing. Please stay home or go home and follow the isolation guidelines.</b>		
<p>If you answered YES with symptoms: Isolation until the following requirements have been met:</p> <ul style="list-style-type: none"> <li>a. 10 days since symptoms first appeared <b>and</b></li> <li>b. 24 hours (1 day) with no fever (without the use of fever-reducing medicine) <b>and</b></li> <li>c. other symptoms have improved</li> </ul> <p>If you test negative, you may return sooner when symptom free for 24 hours (1day) with no fever (without the use of fever-reducing medicine).</p>		

Answered YES to BOTH Questions 1 AND 2:

Service Provider needs to stay home and self-isolate until he/she is asymptomatic for three (3) days without the use of any medications, and it has been at least 7 days since the first day of their symptoms. Service provider MUST ensure coverage of District contracted service event.

Answered YES to ONLY Question 2: If symptoms are secondary to underlying disease (such as allergies or asthma) and not worsened compared to baseline, then service provider can report to district location. If symptoms in Question 2 are NEW, service provider needs to follow the same instructions as noted if both Questions 1 AND 2 are YES. Service provider MUST ensure coverage of District contracted service event.

**Contractor to acknowledge screening requirements noted above and return this form with bid response.**

I acknowledge health screening requirements and the mandate to meet all stated screen requirement as terms and conditions of providing services to the District.

\_\_\_\_\_  
Name of Contractor

By : \_\_\_\_\_ Date: \_\_\_\_\_

**Bidder** \_\_\_\_\_

**DESIGNATION OF SUBCONTRACTORS**

In compliance with the provisions of Sections 4100 to 4114, inclusive, of the Public Contract Code of the State of California, and any amendments thereof, each bidder shall set forth below the name and the location of the mill, shop or office of each subcontractor who will perform work or labor or render service to the Contractor in or about the construction of the work or improvement to be performed under these specifications, in an amount in excess of one-half of 1 percent (0.5%) of the bidder's total bid, and the portion of the work which will be done by each subcontractor.

If the Contractor fails to specify a subcontractor for any portion of the work to be performed under the contract, the Contractor shall be deemed to have agreed to perform such portion itself, and shall not be permitted to subcontract that portion of the work except under the conditions hereinafter set forth.

Subletting or subcontracting of any portion of the work as to which no subcontractor was designated in the original bid shall only be permitted in cases of public emergency or necessity, and then only after a finding reduced to writing as a public record of the legislative body of the Owner.

**Note:** Reproduce for additional listings needed beyond the length of this form.

Portion of Work	Name of Subcontractor	Location & License # of Subcontractor*	Subcontractor DIR Registration #
			10000
			10000
			10000
			10000
			10000
			10000
			10000
			10000
			10000
			10000

\* ***If there are similarly named subcontractors in a particular location, list enough information in this column to differentiate. LOCATION OF SUBCONTRACTOR AND LICENSE NUMBER MUST BE PROVIDED IN BID RESPONSE***

**Listing Subcontractors.** As required pursuant to the Subletting and Subcontracting Fair Practices Act, each bidder shall submit with its bid a list of the names, license numbers, DIR registration numbers, and locations of the places of business of each subcontractor that will perform work or labor or render service to the bidder in or about the Project, or that, under subcontract to the bidder, will specially fabricate and install a portion of the work, in an amount in excess of one-half of 1 percent of the total amount of the bidder's bid. A bidder may not list more than one subcontractor for any one portion of the work. A bidder that fails to list a subcontractor for any portion of the work represents that it is fully qualified to and shall perform such work using its own forces. If the bid documents require the bidder to submit alternate bids and the bidder intends to use different or additional subcontractors for the alternates, the bidder must submit a separate list of subcontractors for each such alternate. A bidder shall submit the lists of subcontractors only on the form included in the bid documents.



**BID # 2848**

**CLOVIS UNIFIED SCHOOL DISTRICT**

**Paving at Various Sites**

**JOB REFERENCES**

Bidders must submit a list of at least three (3) projects of similar dollar volume completed within the last 24 months for reference purposes.

DATE	JOB SITE	CONTACT PERSON	TELEPHONE NUMBER

**NAME OF BIDDER** \_\_\_\_\_

3.97 (8.98)

CLOVIS UNIFIED SCHOOL DISTRICT

SPECIFICATIONS  
FOR THE CONSTRUCTION OF  
2020 PARKING LOT AND PLAYCOURT  
REHABILITATION  
AT  
CLOVIS EAST HIGH SCHOOL  
CLOVIS NORTH HIGH SCHOOL  
CLOVIS WEST HIGH SCHOOL  
COPPER HILLS ELEMENTARY SCHOOL  
CUSD DISTRICT OFFICE  
GARFIELD ELEMENTARY SCHOOL  
REAGAN ELEMENTARY SCHOOL

Plans and Specifications Prepared by:

Blair, Church & Flynn  
Consulting Engineers  
A California Corporation  
451 Clovis Avenue, Suite 200  
Clovis, California 93612  
(559) 326-1400  
(559) 326-1500

IDENTIFICATION STAMP  
DIV. OF THE STATE ARCHITECT  
APP. 02-118053 INC:  
REVIEWED FOR  
SS  FLS  ACS   
DATE: 02/21/2020



CLOVIS UNIFIED SCHOOL DISTRICT

SPECIFICATIONS  
FOR THE CONSTRUCTION OF  
2020 PARKING LOT AND PLAYCOURT  
REHABILITATION  
AT  
CLOVIS EAST HIGH SCHOOL  
CLOVIS NORTH HIGH SCHOOL  
CLOVIS WEST HIGH SCHOOL  
COPPER HILLS ELEMENTARY SCHOOL  
CUSD DISTRICT OFFICE  
GARFIELD ELEMENTARY SCHOOL  
REAGAN ELEMENTARY SCHOOL

Plans and Specifications Prepared by:

Blair, Church & Flynn  
Consulting Engineers  
A California Corporation  
451 Clovis Avenue, Suite 200  
Clovis, California 93612  
(559) 326-1400  
(559) 326-1500

IDENTIFICATION STAMP  
DIV. OF THE STATE ARCHITECT  
APP. 02-118050 INC:  
REVIEWED FOR  
SS  FLS  ACS   
DATE: 02/21/2020



CLOVIS UNIFIED SCHOOL DISTRICT

SPECIFICATIONS  
FOR THE CONSTRUCTION OF  
2020 PARKING LOT AND PLAYCOURT  
REHABILITATION  
AT  
CLOVIS EAST HIGH SCHOOL  
CLOVIS NORTH HIGH SCHOOL  
CLOVIS WEST HIGH SCHOOL  
COPPER HILLS ELEMENTARY SCHOOL  
CUSD DISTRICT OFFICE  
GARFIELD ELEMENTARY SCHOOL  
REAGAN ELEMENTARY SCHOOL

Plans and Specifications Prepared by:

Blair, Church & Flynn  
Consulting Engineers  
A California Corporation  
451 Clovis Avenue, Suite 200  
Clovis, California 93612  
(559) 326-1400  
(559) 326-1500

IDENTIFICATION STAMP  
DIV. OF THE STATE ARCHITECT  
APP. 02-118054 INC:  
REVIEWED FOR  
SS  FLS  ACS   
DATE: 02/28/2020



CLOVIS UNIFIED SCHOOL DISTRICT

SPECIFICATIONS  
FOR THE CONSTRUCTION OF  
2020 PARKING LOT AND PLAYCOURT  
REHABILITATION  
AT

CLOVIS EAST HIGH SCHOOL  
CLOVIS NORTH HIGH SCHOOL  
CLOVIS WEST HIGH SCHOOL  
COPPER HILLS ELEMENTARY SCHOOL  
CUSD DISTRICT OFFICE  
GARFIELD ELEMENTARY SCHOOL  
REAGAN ELEMENTARY SCHOOL

Plans and Specifications Prepared by:

Blair, Church & Flynn  
Consulting Engineers  
A California Corporation  
451 Clovis Avenue, Suite 200  
Clovis, California 93612  
(559) 326-1400  
(559) 326-1500

IDENTIFICATION STAMP  
DIV. OF THE STATE ARCHITECT  
APP. 02-118055 INC:  
REVIEWED FOR  
SS  FLS  ACS   
DATE: 02/21/2020



CLOVIS UNIFIED SCHOOL DISTRICT

SPECIFICATIONS  
FOR THE CONSTRUCTION OF  
2020 PARKING LOT AND PLAYCOURT  
REHABILITATION  
AT  
CLOVIS EAST HIGH SCHOOL  
CLOVIS NORTH HIGH SCHOOL  
CLOVIS WEST HIGH SCHOOL  
COPPER HILLS ELEMENTARY SCHOOL  
CUSD DISTRICT OFFICE  
GARFIELD ELEMENTARY SCHOOL  
REAGAN ELEMENTARY SCHOOL

Plans and Specifications Prepared by:

Blair, Church & Flynn  
Consulting Engineers  
A California Corporation  
451 Clovis Avenue, Suite 200  
Clovis, California 93612  
(559) 326-1400  
(559) 326-1500

IDENTIFICATION STAMP  
DIV. OF THE STATE ARCHITECT  
APP. 02-118051 INC:  
REVIEWED FOR  
SS  FLS  ACS   
DATE: 02/21/2020



CLOVIS UNIFIED SCHOOL DISTRICT

SPECIFICATIONS  
FOR THE CONSTRUCTION OF  
2020 PARKING LOT AND PLAYCOURT  
REHABILITATION  
AT  
CLOVIS EAST HIGH SCHOOL  
CLOVIS NORTH HIGH SCHOOL  
CLOVIS WEST HIGH SCHOOL  
COPPER HILLS ELEMENTARY SCHOOL  
CUSD DISTRICT OFFICE  
GARFIELD ELEMENTARY SCHOOL  
REAGAN ELEMENTARY SCHOOL

Plans and Specifications Prepared by:

Blair, Church & Flynn  
Consulting Engineers  
A California Corporation  
451 Clovis Avenue, Suite 200  
Clovis, California 93612  
(559) 326-1400  
(559) 326-1500

IDENTIFICATION STAMP  
DIV. OF THE STATE ARCHITECT  
APP. 02-118049 INC:  
REVIEWED FOR  
SS  FLS  ACS   
DATE: 02/21/2020

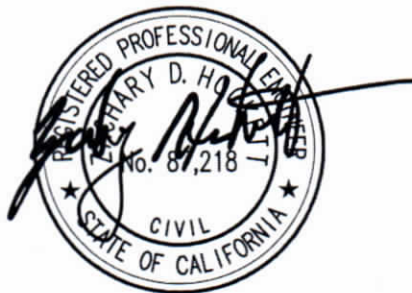

CLOVIS UNIFIED SCHOOL DISTRICT

SPECIFICATIONS  
FOR THE CONSTRUCTION OF

2020 PARKING LOT AND PLAYCOURT  
REHABILITATION  
AT

CLOVIS EAST HIGH SCHOOL  
CLOVIS NORTH HIGH SCHOOL  
CLOVIS WEST HIGH SCHOOL  
COPPER HILLS ELEMENTARY SCHOOL  
CUSD DISTRICT OFFICE  
GARFIELD ELEMENTARY SCHOOL  
REAGAN ELEMENTARY SCHOOL

Plans and Specifications Prepared by:

Blair, Church & Flynn  
Consulting Engineers  
A California Corporation  
451 Clovis Avenue, Suite 200  
Clovis, California 93612  
(559) 326-1400  
(559) 326-1500

IDENTIFICATION STAMP  
DIV. OF THE STATE ARCHITECT

APP. 02-118052 INC:

REVIEWED FOR

SS  FLS  ACS

DATE: 02/21/2020





# TABLE OF CONTENTS

INTRODUCTION

SECTION 1 – GENERAL

SECTION 2 – BIDDING

SECTION 3 – NOT USED

SECTION 4 – SCOPE OF WORK

SECTION 5 – CONTROL OF WORK

SECTION 6 – CONTROL OF MATERIALS

SECTION 7 – LEGAL REGULATIONS AND RESPONSIBILITY TO THE PUBLIC

SECTION 8 – PROSECUTION AND PROGRESS

SECTIONS 9 THROUGH 16 – NOT USED

SECTION 17 – CLEARING AND GRUBBING

SECTION 18 – DUST PALLATIVES

SECTION 19 – EARTHWORK

SECTIONS 20 THROUGH 25 – NOT USED

SECTION 26 – AGGREGATE BASES

SECTIONS 27 THROUGH 28 – NOT USED

SECTION 29 – TREATED PERMEABLE BASES

SECTIONS 30 THROUGH 36 – NOT USED

SECTION 37 – BITUMINOUS SEALS

SECTION 38 – NOT USED

SECTION 39 – ASPHALT CONCRETE

SECTIONS 40 THROUGH 72 – NOT USED

SECTION 73 – CONCRETE IMPROVEMENTS

SECTIONS 74 THROUGH 81 – NOT USED

SECTION 82 – SIGNS AND MERKERS

SECTION 84 – TRAFFIC STRIPES AND PAVEMENT MARKINGS

CLOVIS UNIFIED SCHOOL DISTRICT  
CONSTRUCTION OF 2020 PARKING LOT AND  
PLAYCOURT REHABILITATION IMPROVEMENTS

SPECIAL PROVISIONS

**B. SPECIAL PROVISIONS**

INTRODUCTION

The work covered by this Project shall be done in accordance with these Special Provisions and with the applicable provisions of the Standard Specifications of the State of California, Business and Transportation Agency, Department of Transportation (Caltrans), latest edition, hereinafter referred to as the Standard Specifications; the City of Clovis, City of Fresno, and County of Fresno Standard Plans and Specifications; and Title 21 and Title 24 of the California Code of Regulations (CCR). These Technical Specifications provide additional information, to be used in conjunction with the Standard Specifications, intended to modify or supplement requirements of the Standard Specifications to suit the specific needs of the project.

If a particular section of the Standard Specifications dealing with construction required for this project does not have a like numbered counterpart section in these Special Provisions, such circumstance shall not be construed as an indication that the requirements of that particular section are invalid. Rather, it indicates that the applicable requirements of the Standard Specifications stand as written and shall govern the work. When a like numbered counterpart section is included in these Special Provisions, the requirements of the Standard Specifications shall be considered valid as modified, supplemented, or superseded by the requirements of these Special Provisions. The Standard Specifications and Special Provisions may be collectively referred to hereinafter as "the Specifications."

SECTION 1 - GENERAL

Reference is made to the General Conditions.

SECTION 2 - BIDDING

2-1.08 Examination of Plans, Specifications, Contract, and Site of Work. - The Contractor is required to examine carefully the site of the proposed work, the bid proposal, plans, specifications and Contract Documents for the work contemplated, and it will be assumed that the Contractor (bidder) has investigated and is satisfied as to the conditions to be encountered; as to the character, quality and quantities of the work to be performed and materials to be furnished; and as to the requirements of the specifications, the requirements of the Clovis Unified School District, and the Contract. The submission of a proposal for this work shall be considered prima facie evidence that the Contractor (bidder) has made such examination and is satisfied with the conditions and scope the work.

SECTION 4 - SCOPE OF WORK

4-1.02 Intent of Plans and Specifications. - The Contractor's attention is directed to the provisions of Subsection 4-1.01 of the Standard Specifications. The work to be done consists, in general, of removal of asphalt concrete pavement, concrete curb and sidewalk, signs and wheelstops; and installation of asphalt concrete pavement, concrete curb and sidewalk, wheelstops, pavement striping and marking, signs, and all other related items of work as shown on the construction plans and the specifications for the 2019 Parking Lot and Playcourt Rehabilitation at Various Schools.

All work shall be completed as shown on the plans entitled "Construction of 2019 Parking Lot and Playcourt Rehabilitation at Various Schools," and as indicated in these Technical Specifications.

#### SECTION 5 - CONTROL OF WORK

5-1.04 Coordination and Interpretation of Plans, Standard Specifications, and Special Provisions. - The Contractor's attention is directed to the provisions of Subsection 5-1.04 of the Standard Specifications. The work covered by this Project shall be done in accordance with these Special Provisions and with the applicable provisions of the Standard Specifications; the City of Clovis, City of Fresno, and County of Fresno Standard Plans and Specifications; and Title 21 and Title 24 of the California Code of Regulations (CCR). Shall the referenced specifications conflict with one another, the more stringent requirement shall govern.

5-1.07 Lines and Grades. - No construction staking will be provided to the Contractor. The Contractor shall retain, at his or her own expense, the services of State of California Licensed Land Surveyor or Civil Engineer to provide construction staking for all work involved in the project.

#### SECTION 6 - CONTROL OF MATERIALS

6-1.01 General. - Compaction testing will be done by a firm secured by the Owner for all items of work for which compaction requirements are specified. The Contractor shall give notice to the Engineer a minimum of two working days in advance of the time compaction testing will be required. Compaction tests will be done at locations selected by the Engineer, and the initial tests will be performed at no cost to the Contractor. Further testing in areas requiring recompaction after having failed initial tests will be done at the Contractor's expense, and the cost thereof will be deducted from monies owed the Contractor under progress or final payments. Compaction testing will be done as prescribed for California Test Method 216 (Dry Method) for relative compaction determinations.

6-2.02C Submittals. - The Contractor shall submit copies, checked and approved by him, of all shop drawings, materials and schedules required for the work of the various trades. Submittals shall be delivered promptly so delays in delivery of materials or execution of the work will be avoided. The Engineer will make desired corrections with reasonable promptness and return the submittal to the Contractor. The Contractor shall make any corrections required by the Engineer and submit the required corrected copies for final review and distribution.

The Engineer's review of submittal drawings or schedules shall not relieve the Contractor of responsibility for deviations from the project drawings or specifications, unless he or she has, in writing, called the Engineer's attention to such deviations at the time of original submission and secured written approval from the Engineer. The Engineer's review shall be as complete and thorough as possible but shall not be construed as an "approval" or to relieve the Contractor(s) and material suppliers of responsibility for errors or omissions in the submitted documents.

Promptly after award of the Contract, the Contractor shall prepare and submit to the Engineer a Construction Schedule for the work. The schedule shall be reviewed and revised as necessary for approval by the Engineer and Owner. The Construction Schedule shall show the complete sequence of construction by task. The schedule shall show the dependencies between tasks, show each task's duration and show dates for the beginning and end of each task.

#### Required Submittal Quantities:

- A. Brochures, product information and/or manufacturer's catalog sheets shall be submitted in sequential sets for each material within each category or work: One (1) electronic set shall be submitted.
- B. Shop Drawings, and original details produced for specific portions of the work: One (1) reproducible (sepia) print and bond reproducible print for each sheet or detail.

- C. Samples of finish materials: Minimum of two (2) samples.
- D. Manufactured devices or equipment items: One (1) sample returned to supplier and which, when approved, may be incorporated into the work.
- E. Operating Manuals shall be submitted for all equipment items when required in the various specifications sections. A minimum of three (3) copies unless otherwise noted.

## SECTION 7 - LEGAL RELATIONS AND RESPONSIBILITY TO THE PUBLIC

7-1.02D Permits and Licenses. - The Contractor is responsible to pay all fees and to obtain said permits. The Contractor shall procure the same in accordance with the provisions of Subsection 7-1.04 of the Standard Specifications. An encroachment permit from the City of Clovis, City of Fresno, or County of Fresno is required if work is done within the public right-of-way.

7-1.03 Public Convenience. - Some or all of this work may, of necessity, be required to be done while onsite facilities are being used for other authorized purposes. The Contractor is advised that the construction of this project may be during school hours and therefore, there may be students, faculty, visitors, and District personnel in the vicinity of the work. The Contractor's attention is directed to the applicable provisions of Subsection 7-1.08 of the Standard Specifications.

7-1.04 Public Safety. - The Contractor shall provide safe pedestrian access through or around the work site at all times for the duration of the project. The Contractor shall provide temporary 6' high chain link fencing around the work areas to ensure that students and pedestrians do not get into the work areas. The Contractor's attention is directed to the applicable provisions of Subsection 7-1.09 of the Standard Specifications. Temporary fencing shall be installed between the campus area and the work area.

7-1.02K(6)(b) Preservation of Property. - Prior to excavating, the Contractor shall contact school officials to identify any known utility locations. The Contractor shall exercise extreme caution in excavating and compacting for this project in the area of suspected existing utilities and shall protect existing utilities from damage, inasmuch as their exact location or the exact number of utilities is uncertain.

Attention is also directed to Sections 7-1.06 and 8-1.10 of the Standard Specifications.

7-1.02P Cooperation. - The Contractor shall cooperate with all Clovis Unified School District personnel during their pursuit of normal work activities at the site, whether or not related to this work. There may be other contractors at the site conducting construction or maintenance operations under separate contracts to the District. The Contractor shall cooperate with such other contractors to ensure that his or her activities do not delay or hinder their operations or the related activities of District Personnel. The District reserves the right to direct the order of the Contractor's work at the site as may be necessary to coordinate this work with other onsite operations and activities. The Contractor shall coordinate efforts with the District to ensure that campus irrigation practices and scheduling does not result in the saturation of soils in the work area.

Full compensation for all costs involved in meeting and satisfying the details and requirements specified in this Section shall be included, as part of the contract lump sum bid for the entire project, and no additional payment will be made therefore.

## SECTION 8 - PROSECUTION AND PROGRESS

8-1.04A Beginning of Work. - The Contractor shall begin onsite construction operations within ten (10) calendar days of the commencement date specified by the District in the Notice to Proceed.

8-1.04H Progress Schedule. - The Contractor shall diligently prosecute this work to completion no later than fifty-five (55) calendar days total after the commencement date specified by the District in the

Notice to Proceed. All construction must be completed within the first thirty (30) calendar days of the fifty-five (55) calendar days allotted to the project. The remaining twenty-five (25) calendar days are allotted for the pavement curing period, seal coating, and pavement striping.

At least seven (7) calendar days prior to the commencement date, the Contractor shall submit a proposed progress schedule. The schedule shall indicate the dates proposed for beginning and completion of each part of the work. The schedule will be reviewed by the Engineer for practicability with respect to overall completion time and with respect to potential effects of the work on campus access and parking during construction. No onsite construction operations shall begin prior to the date of the Engineer's approval of the Contractor's proposed progress schedule.

8-1.09 Utility and Non-Highway Facilities. - The Contractor's attention is directed to the provisions of Subsections 7-1.11, 7-1.12, and 8-1.10 of the Standard Specifications. The Contractor shall notify Underground Service Alert (USA), by calling 811, and the District at least 48 hours prior to the scheduled commencement of construction operations to request identification and marking of known utilities in the area of the work. Prior to excavating, the Contractor shall contact school officials to identify any known utility locations. The Contractor shall exercise extreme caution in excavating and compacting for this project in the area of suspected existing utilities and shall protect existing utilities from damage, inasmuch as their exact location or the exact number of utilities is uncertain. The Contractor shall exercise extreme caution in excavation and compaction operations in the area of existing utilities and shall protect them from damage. Marking and identification of utilities shall in no way relieve the Contractor of responsibility to protect and preserve existing utilities and responsibility to repair or replace those damaged as a result of his or her operations. No separate measurement or payment will be made for the protection and preservation of existing utilities or for the repair or replacement of existing utilities damaged by the Contractor, the cost thereof being considered as included in the contract lump sum price for the entire project.

## SECTION 17 - CLEARING AND GRUBBING

17-2.01 Description. - Clearing and Grubbing shall conform to the requirements of Section 16 of the Standard Specifications as modified and supplemented by these Special Provisions and the Plans.

Demolition, where required, shall consist of the clearing of the site, sawcutting, removal of asphalt concrete, pavement structural section, concrete curb and sidewalk, precast concrete wheelstops, post sleeves, signs and other items required to construct new improvements shown on the plans.

Concrete and pavement removal shall conform to the provisions of Section 15 of the Standard Specifications.

17-2.03A Construction. - Where a portion of existing concrete improvements is to be removed, it shall be removed to the next nearest tooled joint or expansion joint of improvements designated to remain. If joint does not exist, sawcut as needed.

Asphalt concrete removal: sawcut to a straight, clean edge. The limits of all items to be removed shall be verified and approved by the Inspector prior to demolition and removal.

In existing turf areas where new paving or concrete facilities are proposed, the existing turf shall be removed to a minimum depth of 6" prior to placing any fill or grading.

17-2.03D Removal and Disposal of Materials. - All materials removed by the Contractor in the course of this work and not designated to be salvaged or relocated onsite shall be legally disposed of by the Contractor at an offsite location secured by the Contractor. Payment of all fees related to disposal is to be paid by the Contractor and the fee shall be included in the lump sum price bid for the work of this contract.

17-2.04 Payment. - Payment for clearing and grubbing will be made as part of the contract lump sum. The price shall be full compensation for doing all work, including all labor, material, tools, equipment and incidentals involved in clearing and grubbing.

## SECTION 18 – DUST PALLIATIVES

18-1.01A Description. - The District will not provide construction water for this project; the Contractor shall develop and pay for a water supply and furnish all water required for the work.

18-1.04 Payment. - No separate payment will be made for construction water, the cost thereof being considered as included in the cost of those items for which it is required. The Contractor shall be responsible for the payment of any and all temporary meter and water use charges imposed by the authority or company from which construction water is obtained.

## SECTION 19 - EARTHWORK

19-1.01A Description. - Earthwork shall conform to the requirements of Section 19 of the Standard Specifications as modified and supplemented by these Special Provisions and the Plans.

Measurement. - No measurement of earthwork operations will be made

19-1.03A Prior to placing any fill material in existing turf areas where new turf is to be established, all existing ground surface shall be scarified. Where new concrete or pavement improvements are to be constructed, all existing turf is to be removed to a minimum depth of six inches.

19-1.03B Unsuitable Material. - Prior to the construction of proposed improvements, the Engineer may require that the Contractor provide and operate a test roller of size and weight meeting the Engineer's approval to identify any soft or spongy areas in the finished subgrade. Subgrade material in such areas shall be removed and replaced to the satisfaction of the Engineer. No additional payment will be made for test rolling or the correction of subgrade deficiencies identified thereby.

19-1.03C Grade Tolerance. - Subgrade shall be accurately graded and compacted to proper profile and section, at elevations determined by subtracting the specified thickness of proposed improvements from finished grade elevations.

Top surface of Subgrade for Non-Vegetative Surface Improvements or Layers thereof: Plus or minus 0.02 foot from planned elevation.

Top surface of Subgrade for Vegetative Surface Improvements or for Bare Ground - Plus or minus 0.05 foot of planned elevation, or as required for finish surface to match adjacent improvements or ground.

The Contractor shall provide smooth transition grading between the limits of grading and new improvements. Included in the grading work are all labor, materials, and equipment to adjust all existing and proposed utility boxes in the area of grading to the new finished grades.

19-1.03A Earthwork Section. - The exposed subgrade shall be excavated/scarified to a depth of at least 12 inches, worked until uniform and free from large clods, moisture conditioned as necessary and recompacted to a minimum of 95% of maximum density based on California Test Method 216 (Dry Method).

Following the preparation of the subgrade, the pavement base sections shall be placed and compacted to a minimum of 95% of maximum density based on California Test Method 216 (Dry Method).

Onsite soils that are determined by the Geotechnical Engineer to be suitable for reuse may be reused as engineered fill, provided they are cleansed of excessive organics, lumps larger than 3-inches, rocks larger than 2-inches, and debris.

Recycled asphalt concrete or aggregate base will be suitable for reuse as engineered fill, provided they are cleansed of excessive organics and debris and they meet the Class 2 aggregate base gradation criteria of the Standard Specifications.

The preferred materials specified for engineered fill are suitable for most applications with the exception of exposure to erosion. Project site protection of exposed soils during the construction phase shall be the sole responsibility of the Contractor, since he or she has complete control of the project site.

Fill soils shall be placed in uncompacted lifts approximately 8-inches thick, moisture-conditioned as necessary and compacted to achieve at least 95% of the maximum dry density as determined by California Test Method 216 (Dry Method). Additional lifts shall be not be placed if the previous lift did not meet the required dry density or if soil conditions are not stable.

19-1.04 Payment. - Payment for earthwork will be made as part of the contract lump sum amount. The price shall be full compensation for doing all work, including furnishing all labor, material, tools, equipment and incidentals involved in the earthwork.

19-3.01C(1) Excavations, depressions, or soft and pliant areas extending below planned finished subgrade levels shall be cleaned to firm, undisturbed soil and backfilled with Engineered Fill. Any buried structures encountered during construction shall be properly removed and backfilled. Concrete footings shall be removed to an equivalent depth of at least 3 feet below proposed footing elevations or as recommended by the Geotechnical Engineer. Any other buried structures shall be removed in accordance with the recommendations of the Geotechnical Engineer. Resulting excavations shall be properly backfilled. The Geotechnical Engineer shall be present during all site clearing and grading operations to test and observe earthwork construction. The Geotechnical Engineer may reject any material that does not meet compaction and stability requirements.

19-5.03 Earthwork compaction shall conform to the requirements of Subsection 19-5 of the Standard Specifications. The relative compaction of all subgrade material, such as that on which aggregate base, asphalt concrete, or Portland cement concrete is to be placed, shall be at least 95% for a minimum depth of twelve inches below subgrade surface.) All soft and spongy material shall be removed to a depth of not less than six inches below subgrade elevation for all hardscape improvements. All compaction in turf and planter areas shall be 85% relative compaction. All relative compaction determinations for the work will be performed in accordance with California Test Method 216 (Dry Method).

196-7.02A Any imported soil to be placed in areas that will receive asphalt or concrete surfacing shall have an "R" value of not less than 50.

Imported non-expansive, non-corrosive fill soil shall consist of a well-graded, slightly cohesive silty sand or sandy silt, with relatively impervious characteristics when compacted. This material shall be approved by the Engineer prior to use and shall be typically possess the following characteristics:

- Maximum Percent Passing No. 200 Sieve – 50%
- Maximum Particle Size – 3"
- Maximum Plasticity Index – 10
- Maximum UBC Standard 29-2 Expansion Index – 15

## SECTION 26 - AGGREGATE BASES

26-1.02B Materials. - Aggregate base shall be a Class 2 aggregate base, with 3/4" maximum gradation .

26-1.03D Spreading. - Placing of imported aggregate shall conform to the requirements of Sections 26-1.03D of the Standard Specifications, except that use of a motor grader will be permitted. The surface of the finished aggregate base at any point shall not vary more than 0.03 feet above or below the specified grade at that point. No more than 50% of the finished surface shall be above or below the specified grade for aggregate base.

26-1.03E Compacting. - The relative compaction of compacted aggregate base material shall not be less than 95% as determined by California Test Method 216 (Dry Method)

26-1.04 Payment. - Payment for aggregate base will be made as part of the contract lump sum amount. The price shall be full compensation for aggregate base, complete and in place, including all labor, materials, tools and equipment required for spreading, compacting and all other items incidental to the work.

26-2.0 Measurement. - No measurement of aggregate base will be made.

#### SECTION 29 – TREATED PERMEABLE BASES

29-1.01A Description - This work shall consist of furnishing and placing pre-emergence herbicide under all new asphaltic concrete pavement.

29-1.01B Standards - In accordance with the following:

CCR-T21	California Code of Regulations, Title 21 Public Works
CBC	California Building Code, California Code of Regulations, Title 24, Part 2, CCR-T24
USDA	United States Department of Agriculture
EPA	Environmental Protection Agency
HSA	The Healthy Schools Act of 2000 (California AB 2260)

All applicable environmental Regulations and Standards.

29-1.01C Submittal - Submit one (1) electronic copy of the following to the Engineer for his or her file and distribution:

1. Product Information.
1. Certificates of Application.
2. Certificate of Compliance for Material.

29-1.01D(1) Quality Assurance - An individual licensed in the State of California shall apply the pre-emergence herbicide. The product shall comply with the current EPA laws at the time of application. The Contractor shall submit the written recommendations from the licensed applicator to the Engineer prior to the application of the herbicide.

29-1.02 Product - The herbicide shall be currently registered by the State Department of Agriculture and the EPA and allowed for the intended use.

29-1.03A Execution – The herbicide shall be applied in accordance with the producer's recommendation, The Healthy Schools Act of 2000 (HAS), and all applicable environmental regulations and standards. Apply the herbicide solution over the surface to be paved prior to the placement of asphalt concrete or other surfacing. The herbicide shall be in spray form and applied at a rate allowable by the State of California and as determined by the licensed applicator. Take all precautions to limit herbicide solution to areas immediately under the proposed pavement. Use shields as necessary and do not apply under windy conditions.

29-1.04 Payment - Payment for soil sterilization will be made as part of the contract lump sum amount for the entire project. The price shall be full compensation for soil sterilization, complete in place, including all labor, material, and tools required for the application for the herbicide and all other item incidental to the work.

29-2.03 Construction - A soil sterilant approved by the Engineer shall be applied over the entire



surface area of the compacted aggregate base rock prior to the placement of asphalt concrete. Soil sterilant shall be applied by an individual licensed for the application of the sterilant. Soil sterilant shall also be applied to all cracks, after cleaning and prior to application of crack filler.

## SECTION 37 – BITUMINOUS SEALS

37-1.01A Description. - This work shall consist of the placement of asphalt-based seal coat at the locations shown on the plans. Asphalt-based seal coat shall be an asphaltic emulsion with selected mineral fillers and blended binders.

37-1.01B Seal Coat. - An asphalt-based seal coat shall be applied over all existing pavement surfaces within the project limits. New pavement surfaces shall not be seal coated, except where called for on the Plans.

37-1.01C Sand Slurry Seal Coat – Where indicated on the plans, a polymer modified asphaltic-based seal coat mixed per the seal coat manufacturer's recommendations shall be applied over all existing pavement surfaces within the project limits.

37-1.02 Materials. – Asphalt-based seal coat shall be either "Ace Seal," as manufactured by Asphalt Coatings Engineering, or equal as approved by the Engineer.

37-1.04 Payment. - Payment for asphalt-based seal coat will be made as part of the contract lump sum amount. The price shall be full compensation for asphalt-based seal coat, complete in place, including all labor, materials, and tools required for surface preparation, seal coat, mineral filler and all other items incidental to the work.

37-2.02A(4)(b) Prior to placement of asphaltic based seal coat, the Contractor must receive written approval from the District Inspector or Engineer. The Contractor must notify the District Inspector and Engineer 48 hours prior to the placement of asphalt-based seal coat.

After the placement of asphaltic-based seal coat, the District Inspector or Engineer must inspect and approve the new seal coat application prior to proceeding. Areas that require additional seal coat shall be provided, as directed by the District Inspector or Engineer.

The District Inspector or Project Engineer is required to inspect and approve crack cleaning and pavement repair locations prior to any seal coat activities. Additional crack cleaning and repair shall be provided to the satisfaction of the District Inspector or Engineer, as directed.

37-2.02C(1) Preparation for Seal Coat. - Immediately prior to applying the sealer, the surface shall be cleaned of all loose material that might adversely affect bonding of the sealer. Any standard cleaning method such as power sweepers and blowers may be employed. In areas where gasoline, grease, oil spots, or chemical stains have been in contact with pavement, "Poly Oil Sil" or approved equal emulsion primer shall be applied to the pavement surface per manufacturer recommendations prior to placing seal coat. In locations where the pavement has been softened by contact with oils, fuels, or other substances, remove and replace pavement as directed by the Engineer.

In existing asphalt concrete pavement, pavement cracks exceeding ½-inch in depth or ¼-inch in width, or both, shall be thoroughly cleaned and repaired with Type A, No. 4 maximum asphalt concrete before placing the sealer. All cracks between ⅛-inch and ¼-inch in width shall be fully cleaned and filled with "Flex Crax," as manufactured by Asphalt Coatings Engineering, or approved equal, in accordance with the manufacturer's recommendations.

Whether or not specifically indicated on the plans, all loose or raveling pavement, potholes and badly distorted or depressed areas, except those lying within areas designated for pavement removal and replacement, shall be properly cleaned and repaired by applying a binder coat and Type A, ⅜-inch maximum asphalt concrete patch conforming to the requirements of Section 39 before placing the seal

coat.

Except as otherwise indicated on the Plans, asphalt-based seal coat shall not be applied to new asphalt concrete pavement. Unless otherwise authorized by the Engineer, asphalt-based seal coat shall not be applied to new asphalt concrete pavement until a minimum of twenty-one (21) calendar days have elapsed since pavement placement.

The new seal coat shall fully cover the appearance of old pavement marking and striping. Otherwise, additional coats of seal coat shall be applied to the surface until the old pavement marking and striping is no longer visible.

Applying Asphaltic Emulsion. - Asphalt-based seal coat shall be applied in accordance with the manufacturer's recommendations. At a minimum, the following application requirements shall be observed.

Two coats of asphalt-based seal coat shall be applied. The first coat shall have added to it a silica sand mineral filler, which has passed a 50 mesh screen, at a rate of 2 to 3 pounds per 1 gallon of concentrated sealer. When the first coat is dry enough to walk on without picking the material up, a second coat shall be applied without mineral filler. If the manufacturer indicates that the product may be diluted, it may be diluted with no more than 20% by volume with clean fresh water with the prior approval of the Engineer. The total application rate shall be as follows.

1. New pavement surfaces – a minimum of 20 gallons of undiluted product per 1,000 square feet, as directed by the Engineer
2. Existing pavement surfaces – a minimum of 35 gallons of undiluted product per 1,000 square feet, as directed by the Engineer.

Applying Polymer Modified Asphaltic Emulsion. – Polymer Modified Asphalt-based seal coat shall be applied in accordance with the manufacturer's recommendations. At a minimum, the following application requirements shall be observed.

Two coats of asphalt-based seal coat shall be applied. The first coat shall have added to it #30 manufactured silica sand, at a rate of 200 to 300 pounds per 100 gallons of concentrated sealer and 1 to 3 gallons of polymer modifier for every 100 gallons of concentrated sealer. When the first coat is dry enough to walk on without picking the material up, a second coat shall be applied without mineral filler or polymer modifier. If the manufacturer indicates that the product may be diluted, it may be diluted with no more than 20% by volume with clean fresh water with the prior approval of the Engineer. The total application rate shall be as follows.

1. New pavement surfaces – a minimum of 20 gallons of undiluted product per 1,000 square feet, as directed by the Engineer
2. Existing pavement surfaces – a minimum of 35 gallons of undiluted product per 1,000 square feet, as directed by the Engineer.

If existing depressions are such that aggregate still protrudes after the second coat of asphalt-based sealer has been applied, the Contractor shall apply a third coat when so directed by the Engineer.

## SECTION 39 - ASPHALT CONCRETE

39-2.01 Description. - Asphalt concrete shall be Type A asphalt concrete produced with aggregate conforming to the grading requirements for ¾" maximum medium aggregate and ½" maximum medium aggregate. Within parking lots and roadways the aggregate shall be ¾" maximum medium. Within the play courts unless otherwise specified on the plans, the aggregate shall be ½" maximum medium. Contractor shall submit to the Engineer for approval prior to ordering any asphalt concrete, the proposed gradation of the asphalt concrete mix proposed for use. No "fine" mixes will be allowed, except for use in crack filling as per the details shown on the plans.

39-2.01A(3)(a) General Proportioning - Before producing asphalt concrete, the Contractor shall submit in writing to the Engineer the gradation of the aggregate and the bitumen ratio for the mix the Contractor proposes to furnish. No asphaltic concrete shall be produced prior to issuance of the Engineer's written approval of the Contractor's proposed aggregate gradation and bitumen ratio. The bitumen ratio shall be no less than 3 and no more than 7 pounds of asphalt per 100 pounds of dry aggregate.

39-2.01B(3) Asphalts. - Asphalt binder to be mixed with aggregate shall be steam-refined paving asphalt conforming to the requirements of Section 92 for viscosity grade (PG 64-10). Asphaltic emulsion for paint binder shall conform to the requirements of Section 94 for Grade SS1, unless otherwise directed or approved by the Engineer.

39-2.01C(1) The Contractor shall taper or feather asphalt concrete to conform to existing surfacing or concrete improvements as directed by the Engineer. No surfacing will be allowed when the air temperature is below 50 degrees F.

Asphaltic concrete shall be laid to the thickness designated on the Plans. The plan thickness is to be considered as a minimum thickness. The Contractor shall lay the asphaltic concrete to a depth required to insure that, after compaction, the in-place compacted thickness is equal to or greater than the specified plan thickness.

39-2.01C(3)(f) Tack Coat and Paint Binder - Where asphalt concrete is placed adjacent to or atop Portland Cement Concrete or asphalt concrete surfaces, except where it is placed atop pavement reinforcing fabric, all surfaces against which asphalt concrete is to be placed shall be coated with a paint binder applied at the rate of no less than 0.02 and no more than 0.10 gallons per square yard. All vertical concrete surfaces that will be in contact with asphalt concrete surfacing and all areas now in place that will be covered with new surfacing materials and feathering operations shall be coated with a paint binder applied at the rate of 0.05 gallons per square yard.

39-2.01A(4)(h)(ii) General Requirements. - The haul vehicles used to transport asphalt concrete from the plant to the job site shall have a 3/8-inch diameter hole located on the driver's side in such a position that the Plant Inspector or Engineer can safely and conveniently insert a thermometer into the asphalt concrete to determine the temperature of the mix from alongside the vehicle. This hole shall be so located that the outside temperature will have a minimum effect on the reading.

The Contractor shall furnish certified load slips to the Engineer as soon as the haul vehicles have been unloaded on the job site.

The Contractor shall provide to the Engineer the truck delivery weight tags for the asphaltic concrete material. The quantity delivered shall be equal to or greater than the calculated in-place quantity based on the specified thickness and area to be paved, as designated on the construction plans and based on a unit density of the asphaltic concrete of 144 pounds per cubic feet.

39-2.01C(15)(a) Compacting. - Compaction operations shall be commenced as soon after spreading as the mixture will support compaction equipment without excessive displacement or deformation. The relative compaction of compacted aggregate base material shall not be less than 95% as determined by ASTM Test Method 1557

39-2.01D Payment. - Payment for asphalt concrete will be made as part of the contract lump sum amount. The price shall be full compensation for asphalt concrete paving, complete in place, including all labor, materials, and tools required for prime coat, paint binder, patching, concrete, spreading, compaction, placement of asphalt-based seal coat and all other items incidental to the work.

## SECTION 73 - CONCRETE IMPROVEMENTS

73-1.01 Description. - This work shall consist of constructing Portland Cement Concrete curb, gutter,

and sidewalk of the form and dimensions shown on the plans and in accordance with the requirements of the Standard Specifications as modified and supplemented by these Special Provisions.

A. General

All concrete improvements shall be installed in accordance with the details shown on the plans.

All off-site work shall comply with the applicable provisions of the City of Clovis, City of Fresno, and/or County of Fresno Standard Drawings and specifications.

All on-site work shall comply with the Plans and all applicable portions of Section 73 of the Standard Specifications.

All concrete shall be, as specified on the plans, 1" x No. 4 aggregate, 6 sack Type II Modified Portland Cement mix, per Section 90 of the Standard Specifications.

B. Construction

Sidewalk, Curb, Gutter, Valley Gutter, Wheelchair Ramp, Mowstrip and Driveway Construction. - After the concrete has been placed, it shall be struck off to proper section and compacted with a grid of parallel metal bars until a layer of mortar not less than 3/8-inch thick has been brought to the surface. All new concrete surfaces shall be broom finished transversely to the line of pedestrian traffic or to the longest dimension of the concrete, as applicable.

C. Finish For Concrete Work

Curbs and mow strips - Trowel smooth and finish with a light brush.

Flat slabs and sidewalks - Medium broom finish, transverse to the primary\y direction of travel.

D. Joints For Concrete Work

The subgrade beneath concrete improvements shall be prepared true to grade and expansion joints for all concrete improvements shall be constructed a minimum of every 45 feet and weakened plane joints shall be placed every 15 feet, except as specifically indicated differently on the Plans.

Expansion joints shall be filled with 3/8-inch thick pre-molded joint filler for the full depth of the joint, conforming to the provisions of Section 51-1.12C of the Standard Specifications. Expansion joints shall be tooled with a 1/4 -inch maximum radius edger.

73-1.03A Prior to pouring any concrete the Contractor shall notify the inspector in order to have the forms inspected and approved. No concrete may be placed without the approval of the inspector

Immediately upon stripping concrete forms and prior to backfill, all rock pockets or honeycombs shall be repaired to the satisfaction of the inspector.

73-1.03B Subgrade Preparation. - Subgrade shall conform to the requirements of Section 19 of these Special Provisions. The subgrade beneath concrete improvements shall be prepared true to grade and cross-section. It shall be compacted to a minimum of 95% relative compaction. All soft and spongy material shall be removed to a depth of not less than six inches below subgrade elevation for all concrete improvements. The District may elect to verify compacted subgrade elevations by measurement made from adjacent existing improvements or by a template supported by forms.

73-1.03E The pigmented curing compound method as described in Section 90 of the Standard

Specifications shall be used for curing all concrete work. The cost of curing compound shall be included in the various concrete bid items. The Contractor shall be responsible for the condition of all concrete work until such time as the contract is finally accepted. The Contractor shall limit vehicular travel across newly poured concrete until such time as the concrete has achieved sufficient strength such that it can support the vehicle weight without being damaged. In no case, however, will vehicles be allowed to cross new concrete improvements until seven (7) calendar days have passed from the date that the concrete was placed.

73-1.04 Payment. - Payment for concrete improvements will be made as part of the contract lump sum amount. The price shall be full compensation for the work, complete in place, including all labor, materials, and tools required for forming, concrete placement, finishing, curing and all other items incidental to the work.

## SECTION 82 – SIGNS AND MARKERS

82-1.01A Description. - Accessible parking signs shall be as shown on the plan and detail drawings, and each parking space for the physically disabled shall be identified by a permanently affixed reflectorized sign. All other signs shall be installed as shown on the plan and detail drawings and shall meet the requirements of Caltrans, City of Clovis, City of Fresno, County of Fresno, and Clovis Unified School District Standards, as applicable.

82-1.04 Payment. - Payment will be made as part of the contract lump sum amount. The price bid shall be full compensation for the work, complete and in place, including all labor, materials, and tools required for furnishing and installation of the signs and all other items incidental to the work.

## SECTION 84 - TRAFFIC STRIPES AND PAVEMENT MARKINGS

84-3.01 Description. - Traffic stripes and pavement marking striping includes the painting of parking stall lines, cross hatching, lettering, disabled symbol and directional arrow and curb painting as shown on the construction plans. Paint on pavement shall not be applied until the asphalt-based seal coat has cured or until a minimum of four (4) days after placement of the seal coat. No paint shall be applied prior to issuance of the Engineer's written approval of the paint material. Paint on curbs, wheelstops, and hardscape shall be scraped clean of loose material prior to striping and painting.

84-3.02 Materials. - Paint shall be either Traffic Line Paint, Fast Dry, White, State of California Specification 8010-12F-04; or Traffic Line Paint, Rapid Dry, White, State of California 8010-12F-02. Blue paint shall be similar to white paint.

84-3.05 Applications. - Paint shall be applied such as to result in a thick uniform appearance that is not translucent. Provide two (2) coats of paint. The international symbol of accessibility shall be painted in blue on the surface of each parking space indicated and shall be a minimum of 3-foot square with a white symbol painted on a blue background. The stall lines for the disabled stall shall also be blue.

All parking lot painting shall be white unless otherwise indicated. All painted stall stripes shall be a minimum of four inches in width. Playcourt paint colors shall be as indicated on the plans, or if not indicated, as directed by the District.

Traffic directional arrow and lettering locations are shown schematically on the construction plans. Arrows shall be centered, or double arrow centered within the traffic aisles and located at the approximate location shown on the plan. Arrow dimensions shown in the arrow detail are minimum dimensions. Arrow may be larger; however, it shall have the same proportions.

84-3.07 Payment. - Payment for traffic stripes and pavement markings will be made as part of the contract lump sum amount. The price shall be full compensation for the work, complete and in place, including all labor, materials and tools required for furnishing and installation of traffic striping and pavement markers and all other items incidental to the work.

END OF SECTION

# CLOVIS UNIFIED SCHOOL DISTRICT

EIMEAR O'FARRELL, ED. D., DISTRICT SUPERINTENDENT

PLANS FOR THE CONSTRUCTION

OF  
2021 PARKING LOT

REHABILITATION IMPROVEMENTS

AT  
CLOVIS EAST AG FARM

FORM 1204 (08/2014)  
APP # 02-178053



**LOCATION MAP**  
NOT TO SCALE

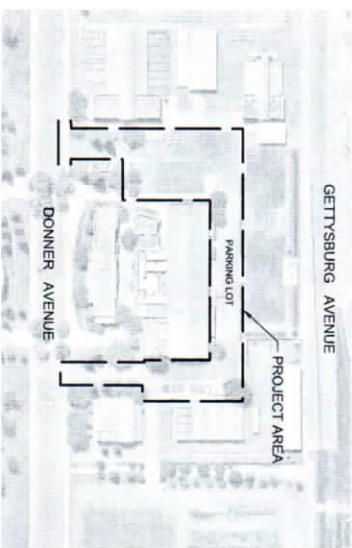

**SITE MAP**  
NOT TO SCALE

ADDRESS  
2916 LINDSAY AVE  
CLOVIS, CA 93611

**PROJECT CONTACTS:**

OWNER: CLOVIS UNIFIED SCHOOL DISTRICT  
1600 HENDON AVE  
CLOVIS, CA 93611  
PHONE: (559) 977-9800

CONTRACTOR: BLAIR CHURCH & FLYNN  
4911 LINDSAY AVE, SUITE 200  
CLOVIS, CA 93611  
PHONE: (559) 281-4800

**SCOPE OF WORK:**

1. GRASS FILL AND SOIL COAT APPLIED TO PARKING LOT
2. RE-STRENGTHEN LOT
3. SPORTY ACCESSIBLE & PAVED TOW SHOULDER
4. IMPROVE AND REPAIR AND DRAINAGE OR MAKE COMPLIANT WITH ADA
5. PAVEMENT
6. REMOVE AND REFACE EXISTING ASPHALT ON DONNER AVENUE FOR CITY OF CLOVIS STANDARDS

**APPLICABLE CODES:**

2018 CALIFORNIA PLUMBING CODE, TITLE 24 PART 1, CODE  
2018 CALIFORNIA MECHANICAL CODE, TITLE 24 PART 2, CODE

**FLOOD HAZARD ZONE INFORMATION:**

1. FLOOD ZONE DESIGNATION: FLOOD HAZARD ZONE 6 AREA 1 OF SPECIAL FLOOD HAZARD
2. FLOOD HAZARD DESIGNATION: MAP 4 APPROXIMATELY
3. FLOOD EFFECTIVE DATE: FEBRUARY 18, 2006
4. FLOOD HAZARD BY FLOODING: N/A

**GENERAL NOTES:**

1. ALL WORK SHALL BE DONE IN ACCORDANCE WITH THE CONSTRUCTION DOCUMENTS AND CITY OF CLOVIS STANDARDS AND SPECIFICATIONS. THE CITY ENGINEER AND THE CONTRACTOR SHALL COORDINATE ALL CONSTRUCTION ACTIVITIES WITH THE SOLE CONTRACTOR FOR THE FACILITIES AND OTHER CONTRACTORS WHO MAY BE WORKING ON THE PROJECT SITE.
2. THE CONTRACTOR SHALL MAINTAIN ALL EXISTING UTILITIES AND STRUCTURES AND OBTAIN ALL NECESSARY PERMITS AND APPROVALS FROM THE CITY OF CLOVIS.
3. THE CONTRACTOR SHALL NOTIFY ALL UTILITIES AND STRUCTURE OWNERS OF THE PROJECT SITE AND OBTAIN ALL NECESSARY PERMITS AND APPROVALS FROM THE CITY OF CLOVIS.
4. ALL CONSTRUCTION SHALL COMPLY WITH THE REQUIREMENTS OF THE 2018 CALIFORNIA PLUMBING CODE (CPC).
5. CONSOLE TO THE APPLICABLE REQUIREMENTS AND SPECIFICATIONS SHALL BE MADE BY THE CONTRACTOR.
6. A 10% GENERAL CLASS PROJECT INSPECTION REPORT SHALL BE SUBMITTED BY THE CONTRACTOR TO THE CITY OF CLOVIS ENGINEER AND THE CITY OF CLOVIS ENGINEER SHALL SIGN AND DATE THE REPORT.
7. A 10% GENERAL CLASS PROJECT INSPECTION REPORT SHALL BE SUBMITTED BY THE CONTRACTOR TO THE CITY OF CLOVIS ENGINEER AND THE CITY OF CLOVIS ENGINEER SHALL SIGN AND DATE THE REPORT.
8. A 10% GENERAL CLASS PROJECT INSPECTION REPORT SHALL BE SUBMITTED BY THE CONTRACTOR TO THE CITY OF CLOVIS ENGINEER AND THE CITY OF CLOVIS ENGINEER SHALL SIGN AND DATE THE REPORT.
9. A 10% GENERAL CLASS PROJECT INSPECTION REPORT SHALL BE SUBMITTED BY THE CONTRACTOR TO THE CITY OF CLOVIS ENGINEER AND THE CITY OF CLOVIS ENGINEER SHALL SIGN AND DATE THE REPORT.
10. THE CONTRACTOR SHALL MAINTAIN ALL EXISTING UTILITIES AND STRUCTURES AND OBTAIN ALL NECESSARY PERMITS AND APPROVALS FROM THE CITY OF CLOVIS.
11. THE CONTRACTOR SHALL MAINTAIN ALL EXISTING UTILITIES AND STRUCTURES AND OBTAIN ALL NECESSARY PERMITS AND APPROVALS FROM THE CITY OF CLOVIS.
12. THE CONTRACTOR SHALL MAINTAIN ALL EXISTING UTILITIES AND STRUCTURES AND OBTAIN ALL NECESSARY PERMITS AND APPROVALS FROM THE CITY OF CLOVIS.
13. THE CONTRACTOR SHALL MAINTAIN ALL EXISTING UTILITIES AND STRUCTURES AND OBTAIN ALL NECESSARY PERMITS AND APPROVALS FROM THE CITY OF CLOVIS.
14. THE CONTRACTOR SHALL MAINTAIN ALL EXISTING UTILITIES AND STRUCTURES AND OBTAIN ALL NECESSARY PERMITS AND APPROVALS FROM THE CITY OF CLOVIS.
15. THE CONTRACTOR SHALL MAINTAIN ALL EXISTING UTILITIES AND STRUCTURES AND OBTAIN ALL NECESSARY PERMITS AND APPROVALS FROM THE CITY OF CLOVIS.
16. THE CONTRACTOR SHALL MAINTAIN ALL EXISTING UTILITIES AND STRUCTURES AND OBTAIN ALL NECESSARY PERMITS AND APPROVALS FROM THE CITY OF CLOVIS.



CONST. DOCUMENTS  
CE-1

**TABLE OF CONTENTS**

SHEET NUMBER	SHEET TITLE
CS-1	COVER SHEET
CS-2	ACCESS COMPLIANCE PLAN
CS-3	BIT AND DIMENSION PLAN
CS-4	DETAILS
TOTAL SHEET COUNT: 4	



Blair Church & Flynn  
CLOVIS, CA 93611  
TEL: (559) 281-4800  
WWW.BCFCONTRACTORS.COM



CLOVIS UNIFIED SCHOOL DISTRICT  
2021 PARKING LOT REHABILITATION  
VARIOUS SITES  
CLOVIS EAST AG FARM  
COVER SHEET

GETTYSBURG AVENUE

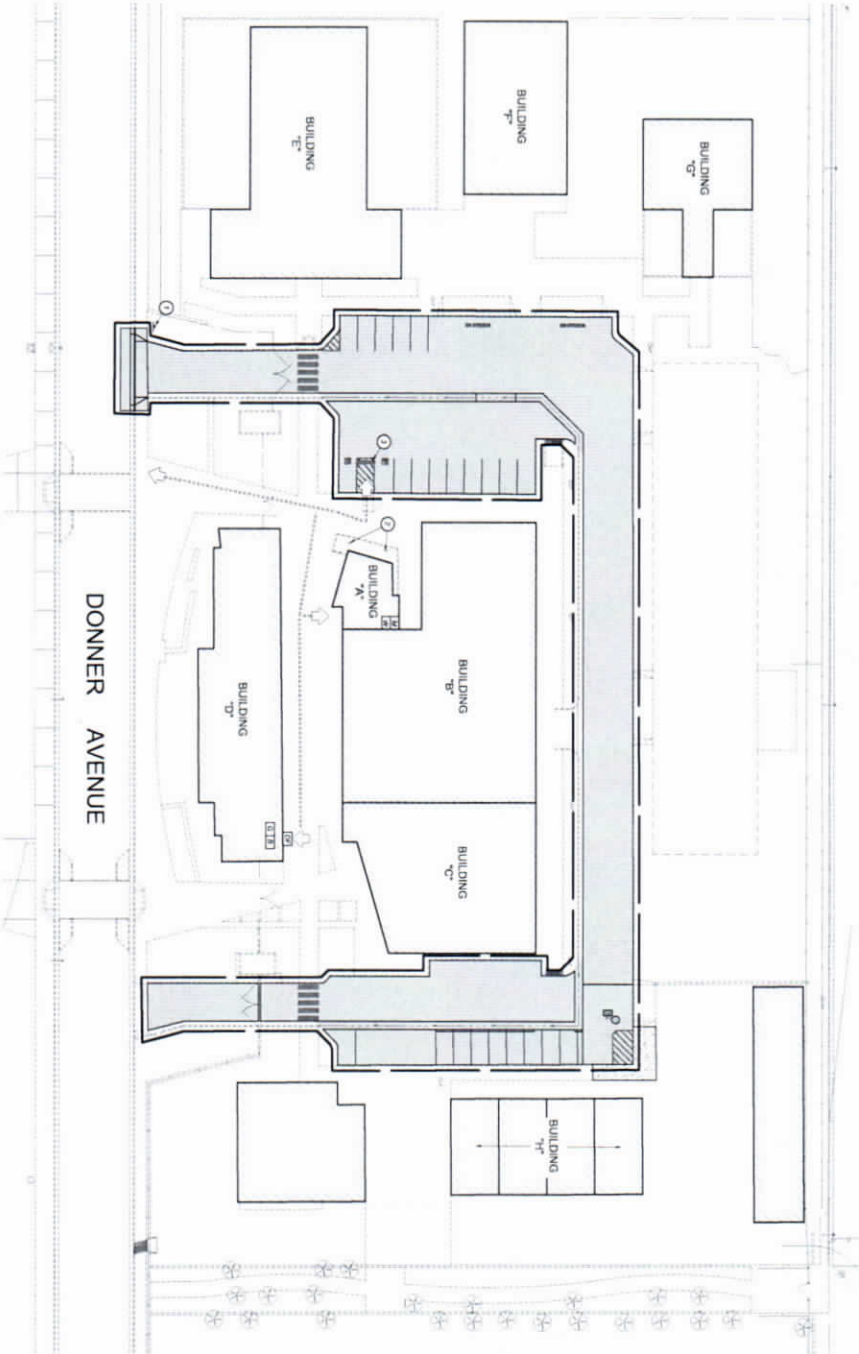

FORM: SDAI (USE ONLY) APP # 02-118053

**SITE LEGEND**

- 1 LIMIT OF WORK
- 2 EXISTING ACCESSIBLE PATH OF TRAVEL PER SDAI APP 02-118053
- 3 ACCESSIBLE PATH OF TRAVEL PER SDAI APP 02-118053
- 4 ACCESSIBLE PATH OF TRAVEL PER SDAI APP 02-118053
- 5 ACCESSIBLE PATH OF TRAVEL PER SDAI APP 02-118053
- 6 ACCESSIBLE PATH OF TRAVEL PER SDAI APP 02-118053
- 7 ACCESSIBLE PATH OF TRAVEL PER SDAI APP 02-118053
- 8 ACCESSIBLE PATH OF TRAVEL PER SDAI APP 02-118053
- 9 ACCESSIBLE PATH OF TRAVEL PER SDAI APP 02-118053
- 10 ACCESSIBLE PATH OF TRAVEL PER SDAI APP 02-118053
- 11 ACCESSIBLE PATH OF TRAVEL PER SDAI APP 02-118053
- 12 ACCESSIBLE PATH OF TRAVEL PER SDAI APP 02-118053
- 13 ACCESSIBLE PATH OF TRAVEL PER SDAI APP 02-118053
- 14 ACCESSIBLE PATH OF TRAVEL PER SDAI APP 02-118053
- 15 ACCESSIBLE PATH OF TRAVEL PER SDAI APP 02-118053
- 16 ACCESSIBLE PATH OF TRAVEL PER SDAI APP 02-118053
- 17 ACCESSIBLE PATH OF TRAVEL PER SDAI APP 02-118053
- 18 ACCESSIBLE PATH OF TRAVEL PER SDAI APP 02-118053
- 19 ACCESSIBLE PATH OF TRAVEL PER SDAI APP 02-118053
- 20 ACCESSIBLE PATH OF TRAVEL PER SDAI APP 02-118053

**NOTES**

- 1 THE PLAN OF THIS PROJECT IS TO BE CONSTRUCTED IN ACCORDANCE WITH THE SDAI APP 02-118053.
- 2 THE PLAN OF THIS PROJECT IS TO BE CONSTRUCTED IN ACCORDANCE WITH THE SDAI APP 02-118053.
- 3 THE PLAN OF THIS PROJECT IS TO BE CONSTRUCTED IN ACCORDANCE WITH THE SDAI APP 02-118053.
- 4 THE PLAN OF THIS PROJECT IS TO BE CONSTRUCTED IN ACCORDANCE WITH THE SDAI APP 02-118053.
- 5 THE PLAN OF THIS PROJECT IS TO BE CONSTRUCTED IN ACCORDANCE WITH THE SDAI APP 02-118053.
- 6 THE PLAN OF THIS PROJECT IS TO BE CONSTRUCTED IN ACCORDANCE WITH THE SDAI APP 02-118053.
- 7 THE PLAN OF THIS PROJECT IS TO BE CONSTRUCTED IN ACCORDANCE WITH THE SDAI APP 02-118053.
- 8 THE PLAN OF THIS PROJECT IS TO BE CONSTRUCTED IN ACCORDANCE WITH THE SDAI APP 02-118053.
- 9 THE PLAN OF THIS PROJECT IS TO BE CONSTRUCTED IN ACCORDANCE WITH THE SDAI APP 02-118053.
- 10 THE PLAN OF THIS PROJECT IS TO BE CONSTRUCTED IN ACCORDANCE WITH THE SDAI APP 02-118053.
- 11 THE PLAN OF THIS PROJECT IS TO BE CONSTRUCTED IN ACCORDANCE WITH THE SDAI APP 02-118053.
- 12 THE PLAN OF THIS PROJECT IS TO BE CONSTRUCTED IN ACCORDANCE WITH THE SDAI APP 02-118053.
- 13 THE PLAN OF THIS PROJECT IS TO BE CONSTRUCTED IN ACCORDANCE WITH THE SDAI APP 02-118053.
- 14 THE PLAN OF THIS PROJECT IS TO BE CONSTRUCTED IN ACCORDANCE WITH THE SDAI APP 02-118053.
- 15 THE PLAN OF THIS PROJECT IS TO BE CONSTRUCTED IN ACCORDANCE WITH THE SDAI APP 02-118053.
- 16 THE PLAN OF THIS PROJECT IS TO BE CONSTRUCTED IN ACCORDANCE WITH THE SDAI APP 02-118053.
- 17 THE PLAN OF THIS PROJECT IS TO BE CONSTRUCTED IN ACCORDANCE WITH THE SDAI APP 02-118053.
- 18 THE PLAN OF THIS PROJECT IS TO BE CONSTRUCTED IN ACCORDANCE WITH THE SDAI APP 02-118053.
- 19 THE PLAN OF THIS PROJECT IS TO BE CONSTRUCTED IN ACCORDANCE WITH THE SDAI APP 02-118053.
- 20 THE PLAN OF THIS PROJECT IS TO BE CONSTRUCTED IN ACCORDANCE WITH THE SDAI APP 02-118053.

**BUILDING LEGEND**

NO.	DESCRIPTION	AREA
1	ADMINISTRATIVE	1,200 SQ. FT.
2	CLASSROOM	1,500 SQ. FT.
3	CLASSROOM	1,500 SQ. FT.
4	CLASSROOM	1,500 SQ. FT.
5	CLASSROOM	1,500 SQ. FT.
6	CLASSROOM	1,500 SQ. FT.
7	CLASSROOM	1,500 SQ. FT.
8	CLASSROOM	1,500 SQ. FT.
9	CLASSROOM	1,500 SQ. FT.
10	CLASSROOM	1,500 SQ. FT.

**PARKING CALCULATIONS:**

TYPE	NO.	TOTAL
1	10	10
2	10	10
3	10	10
4	10	10
5	10	10
6	10	10
7	10	10
8	10	10
9	10	10
10	10	10

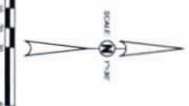

**Blair Church Flynn**

CONSULTING, INC. 3800 S. 10TH ST. SUITE 100, LINCOLN, NE 68502

**Blair Church Flynn**

CONSULTING, INC. 3800 S. 10TH ST. SUITE 100, LINCOLN, NE 68502

2021 RENOVATION REHABILITATION CLOVIS EAST AG FARM ACCESS COMPLIANCE PLAN

CE-2

CLOVIS UNIFIED SCHOOL DISTRICT





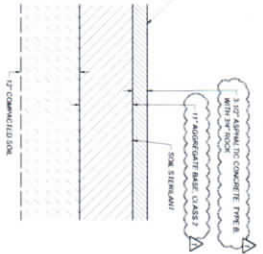

**A** ASPHALT CONCRETE PAVEMENT SECTION  
 CEX-1.1 NOT TO SCALE

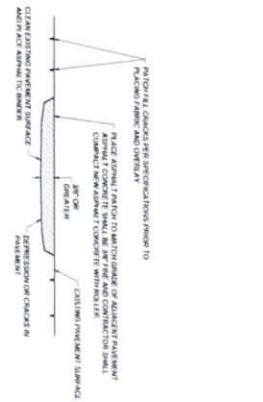

**B** CRACK PATCHING DETAIL  
 CEX-1.1 NOT TO SCALE

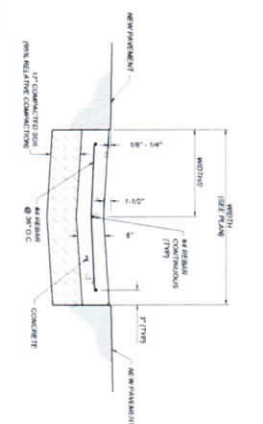

**C** CONCRETE VALLEY GUTTER  
 CEX-1.1 NOT TO SCALE

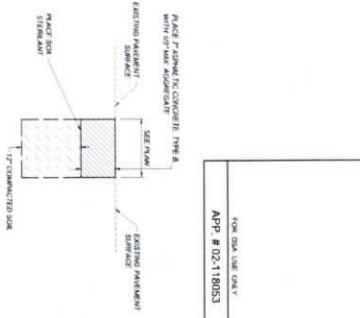

**D** ASPHALT CONCRETE PLUG  
 CEX-1.1 NOT TO SCALE

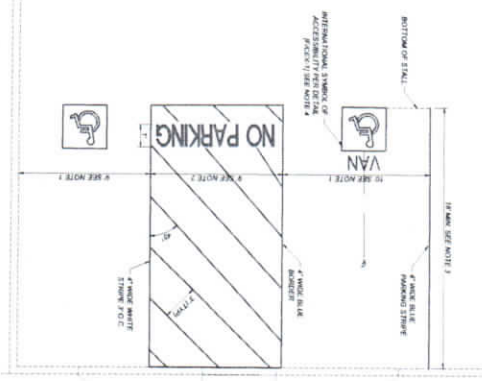

**E** ACCESSIBLE E PARKING STALL DETAIL  
 CEX-1.1 NOT TO SCALE

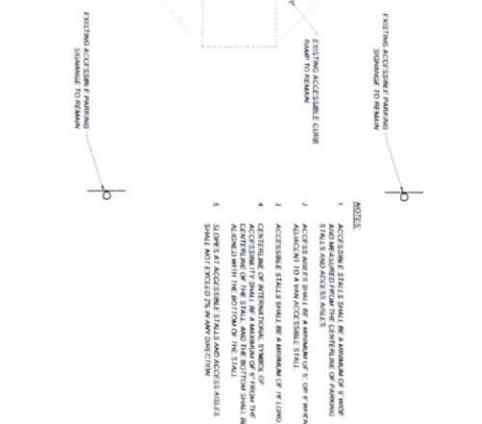

**F** ACCESSIBLE SYMBOL  
 CEX-1.1 NOT TO SCALE

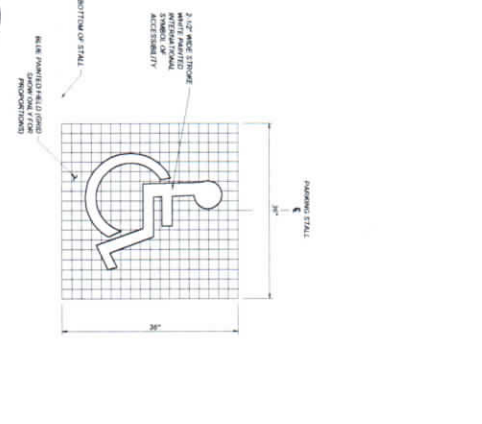

**G** DOWEL BAR DETAIL  
 CEX-1.1 NOT TO SCALE

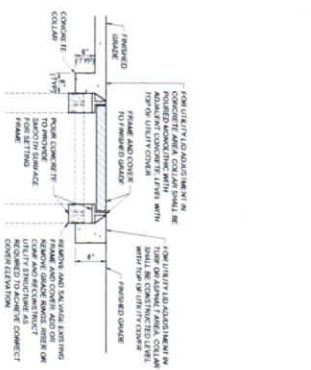

**H** ADJUST UTILITY LID  
 CEX-1.1 NOT TO SCALE

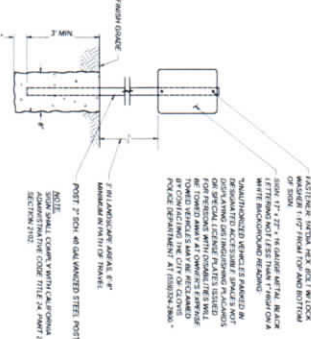

**I** ENTRY SIGN  
 CEX-1.1 NOT TO SCALE

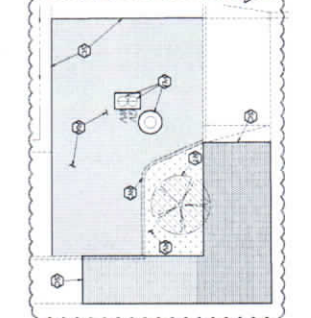

**J** PARTIAL DEMOLITION PLAN  
 CEX-1.1 SCALE 1/8\"/>

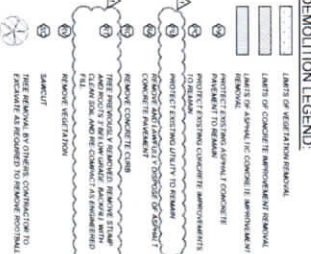

**K** DEMOLITION LEGEND  
 CEX-1.1 NOT TO SCALE

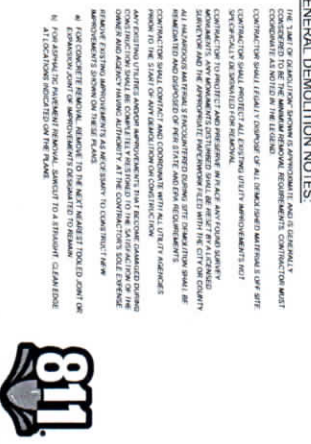

**L** GENERAL DEMOLITION NOTES  
 CEX-1.1 NOT TO SCALE

Blair Church Hymn  
 CLOVIS UNIFIED SCHOOL DISTRICT  
 2021 PAVEMENT REHABILITATION  
 CLOVIS EAST AG FARM  
 DETAILS  
 CONST. DOCUMENTS  
 CEX-1.1  
 811  
 Know what's Below.  
 Call before you dig.

# CLOVIS UNIFIED SCHOOL DISTRICT

EIMEAR O'FARRELL, ED. D., DISTRICT SUPERINTENDENT

PLANS FOR THE CONSTRUCTION

OF

2021 PARKING LOT

REHABILITATION IMPROVEMENTS

AT

CLOVIS NORTH HIGH SCHOOL

DATE: 02-11-2021  
APP: # 02-118000

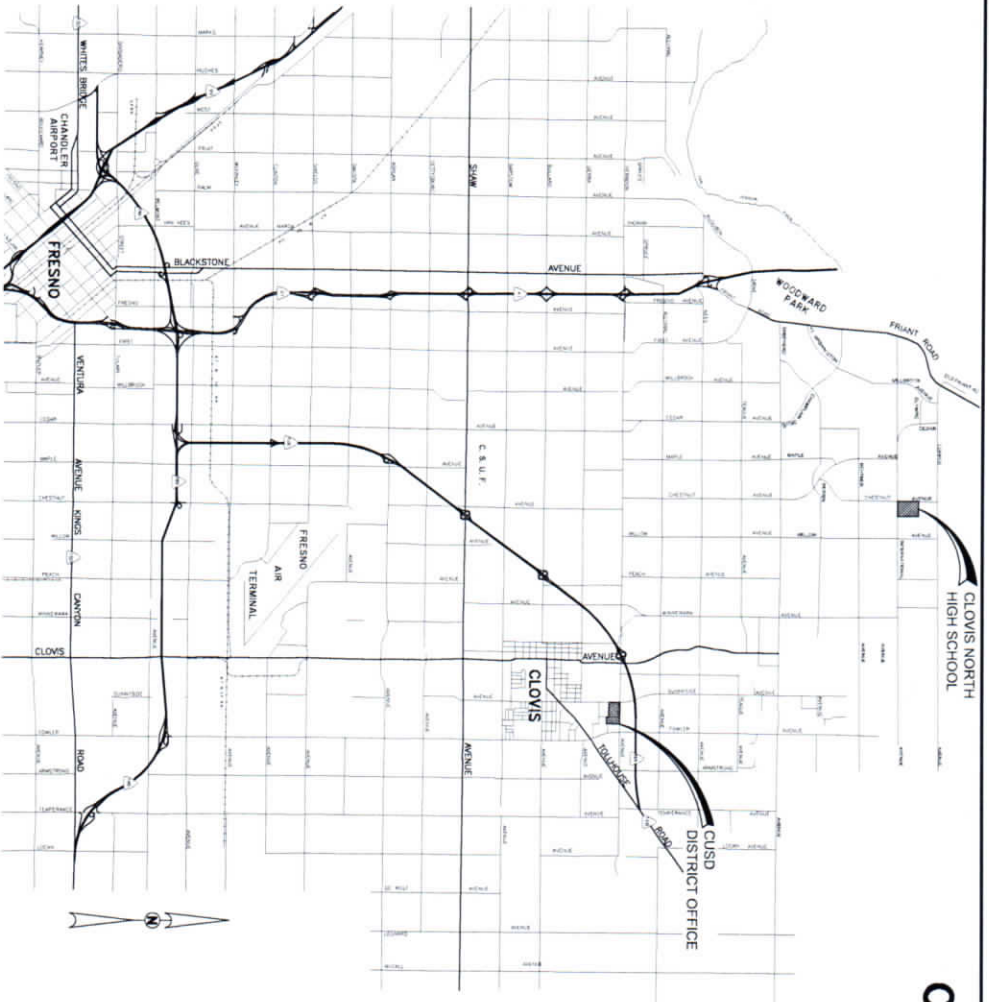

## LOCATION MAP

NOT TO SCALE

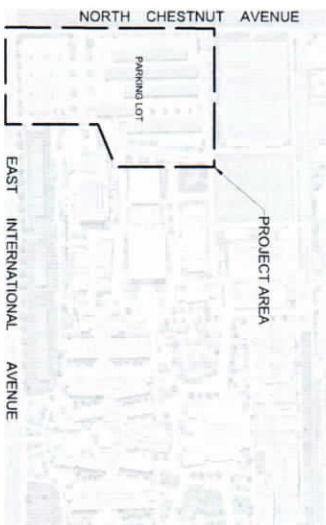

## SITE MAP

NOT TO SCALE

SITE ADDRESS  
2310 INTERNATIONAL AVE  
FRESNO, CA 93728

### PROJECT CONTACTS:

OWNER: CLOVIS UNIFIED SCHOOL DISTRICT  
CLOVIS, CA 93611  
PHONE: (559) 221-2000  
FAX: (559) 221-2000  
PROJECT MANAGER: EIMEAR O'FARRELL  
415 CLOVIS AVENUE, SUITE 700  
CLOVIS, CA 93611  
PHONE: (559) 228-1440

### SCOPE OF WORK:

1. FURNISH AND INSTALL CONCRETE PAVEMENT
2. SEAL JOINTS IN NEW AND EXISTING ASPHALT CONCRETE
3. REPAIR/REPLACE/REMOVE AND REINSTALL NEW ADA COMPLIANT SIGNAGE
4. FURNISH AND INSTALL CONCRETE CURB

### FLOOD HAZARD ZONE INFORMATION:

1. FLOOD ZONE DESIGNATION: ZONE 1, AREA OF MINIMAL FLOODING
2. FLOOD HAZARD DESCRIPTION: MAJOR FLOODING
3. FLOOD EFFECTIVE DATE: 11/26/2009
4. MAP FLOOD ELEVATION: N/A

### GENERAL NOTES:

1. ALL WORK SHALL BE DONE IN ACCORDANCE WITH THE CITY CONSTRUCTION ORDINANCES AND THE STATE OF CALIFORNIA STANDARD SPECIFICATIONS.
2. THE CONTRACTOR SHALL COORDINATE ALL CONSTRUCTION ACTIVITIES WITH THE CLOVIS UNIFIED SCHOOL DISTRICT AND THE CITY OF CLOVIS.
3. THE CONTRACTOR SHALL CONTACT DISTRICT OFFICES FOR INFORMATION ON THE PROJECT AND FOR ANY NECESSARY PERMITS.
4. BEFORE CONSTRUCTION WORK, THE CONTRACTOR SHALL NOTIFY ALL UTILITIES AND OBTAIN NECESSARY PERMITS FROM THE CITY OF CLOVIS AND THE STATE OF CALIFORNIA.
5. ALL CONSTRUCTION SHALL COMPLY WITH THE REQUIREMENTS OF THE 2018 CALIFORNIA BUILDING CODE.
6. CHANGES TO THE AGREEMENT OR SPECIFICATIONS SHALL BE MADE BY ADDENDUM OR CHANGE ORDER.
7. A 15% RETENTION FUND SHALL BE WITHHELD BY THE CITY OF CLOVIS.
8. THE CONTRACTOR SHALL MAINTAIN ACCESS TO ALL ADJACENT PROPERTIES AT ALL TIMES.
9. A 15% RETENTION FUND SHALL BE WITHHELD BY THE CITY OF CLOVIS.
10. THE CONTRACTOR SHALL MAINTAIN ACCESS TO ALL ADJACENT PROPERTIES AT ALL TIMES.



TABLE OF CONTENTS	
SHEET NUMBER	SHEET TITLE
CN-1	COVER SHEET
CN-2	ACCESS COMPLIANCE PLAN
CN-3	BITF AND DIMENSION PLAN
CN-4	DETAILS
CN-5	DETAILS
TOTAL SHEET COUNT: 5	



CONTRACT NO.	2021 UNIFIED SCHOOL DISTRICT
DATE OF CONTRACT	02/11/2021
PROJECT NAME	CLOVIS UNIFIED SCHOOL DISTRICT
PROJECT ADDRESS	2310 INTERNATIONAL AVE, CLOVIS, CA 93611
PROJECT DESCRIPTION	2021 PARKING LOT REHABILITATION IMPROVEMENTS AT CLOVIS NORTH HIGH SCHOOL
PROJECT SHEET	COVER SHEET



CONTRACT NO.	2021 UNIFIED SCHOOL DISTRICT
DATE OF CONTRACT	02/11/2021
PROJECT NAME	CLOVIS UNIFIED SCHOOL DISTRICT
PROJECT ADDRESS	2310 INTERNATIONAL AVE, CLOVIS, CA 93611
PROJECT DESCRIPTION	2021 PARKING LOT REHABILITATION IMPROVEMENTS AT CLOVIS NORTH HIGH SCHOOL
PROJECT SHEET	COVER SHEET

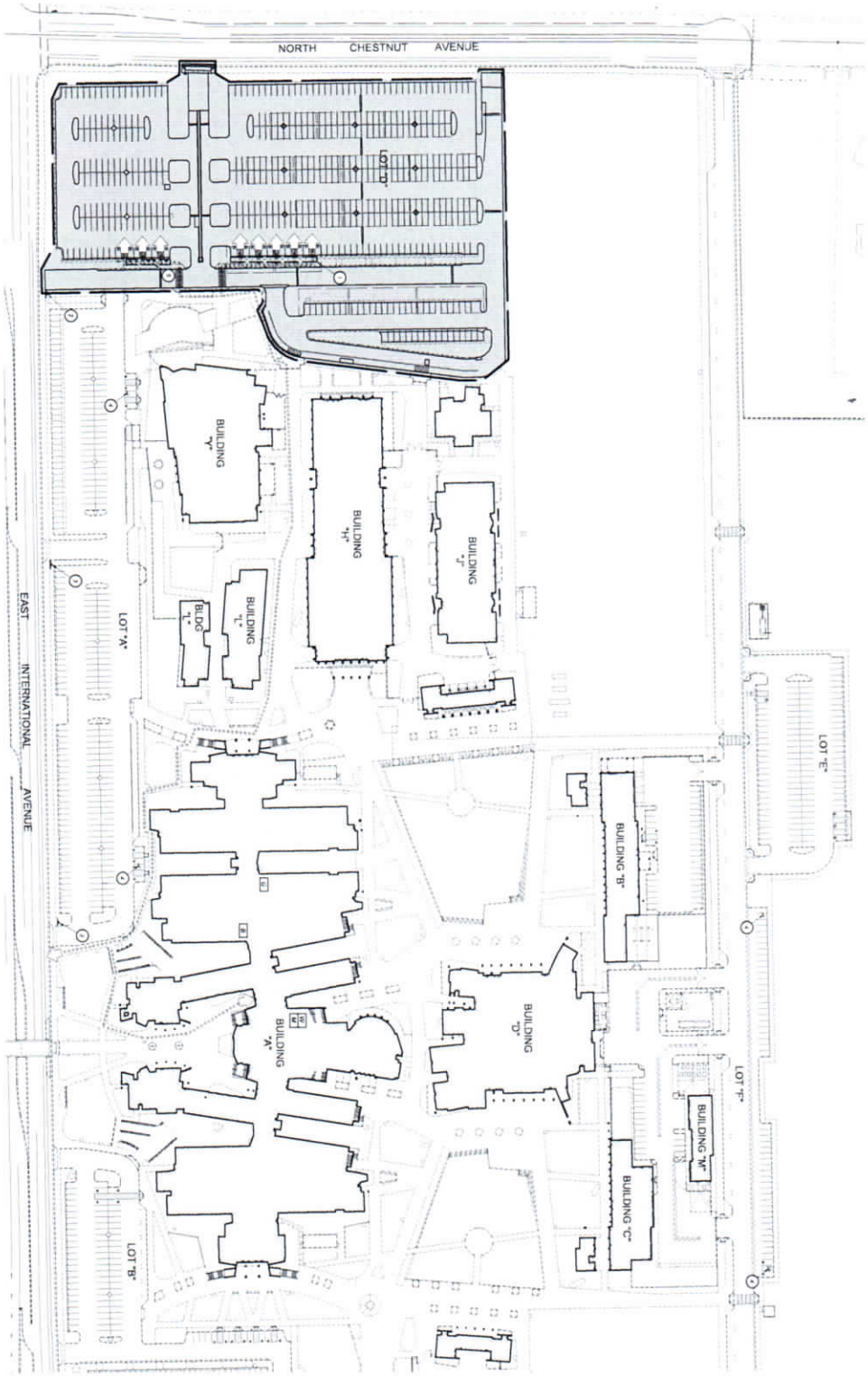

**PARKING CALCULATIONS**

USE	SEAL AREA	NO. OF SPACES	PERCENTAGE OF TOTAL
A	62,158 SQ. FT.	281	4.7%
B	67,558 SQ. FT.	294	4.9%
C	67,558 SQ. FT.	294	4.9%
D	67,558 SQ. FT.	294	4.9%
E	67,558 SQ. FT.	294	4.9%
F	67,558 SQ. FT.	294	4.9%
G	67,558 SQ. FT.	294	4.9%
H	67,558 SQ. FT.	294	4.9%
I	67,558 SQ. FT.	294	4.9%
J	67,558 SQ. FT.	294	4.9%
K	67,558 SQ. FT.	294	4.9%
L	67,558 SQ. FT.	294	4.9%
M	67,558 SQ. FT.	294	4.9%
TOTAL	675,580 SQ. FT.	2,940	49.0%

- BUILDING LEGEND:**
- A COMMUNICATIONS CENTER
  - B COMMUNICATIONS CENTER
  - C COMMUNICATIONS CENTER
  - D COMMUNICATIONS CENTER
  - E COMMUNICATIONS CENTER
  - F COMMUNICATIONS CENTER
  - G COMMUNICATIONS CENTER
  - H COMMUNICATIONS CENTER
  - I COMMUNICATIONS CENTER
  - J COMMUNICATIONS CENTER
  - K COMMUNICATIONS CENTER
  - L COMMUNICATIONS CENTER
  - M COMMUNICATIONS CENTER

**NOTES:**

- THE OWNER SHALL PROVIDE ALL UTILITIES AND CONNECTIONS TO THE BUILDING. THE OWNER SHALL BE RESPONSIBLE FOR THE COST OF ALL UTILITIES AND CONNECTIONS TO THE BUILDING.
- THE OWNER SHALL PROVIDE ALL UTILITIES AND CONNECTIONS TO THE BUILDING. THE OWNER SHALL BE RESPONSIBLE FOR THE COST OF ALL UTILITIES AND CONNECTIONS TO THE BUILDING.
- THE OWNER SHALL PROVIDE ALL UTILITIES AND CONNECTIONS TO THE BUILDING. THE OWNER SHALL BE RESPONSIBLE FOR THE COST OF ALL UTILITIES AND CONNECTIONS TO THE BUILDING.
- THE OWNER SHALL PROVIDE ALL UTILITIES AND CONNECTIONS TO THE BUILDING. THE OWNER SHALL BE RESPONSIBLE FOR THE COST OF ALL UTILITIES AND CONNECTIONS TO THE BUILDING.
- THE OWNER SHALL PROVIDE ALL UTILITIES AND CONNECTIONS TO THE BUILDING. THE OWNER SHALL BE RESPONSIBLE FOR THE COST OF ALL UTILITIES AND CONNECTIONS TO THE BUILDING.
- THE OWNER SHALL PROVIDE ALL UTILITIES AND CONNECTIONS TO THE BUILDING. THE OWNER SHALL BE RESPONSIBLE FOR THE COST OF ALL UTILITIES AND CONNECTIONS TO THE BUILDING.
- THE OWNER SHALL PROVIDE ALL UTILITIES AND CONNECTIONS TO THE BUILDING. THE OWNER SHALL BE RESPONSIBLE FOR THE COST OF ALL UTILITIES AND CONNECTIONS TO THE BUILDING.
- THE OWNER SHALL PROVIDE ALL UTILITIES AND CONNECTIONS TO THE BUILDING. THE OWNER SHALL BE RESPONSIBLE FOR THE COST OF ALL UTILITIES AND CONNECTIONS TO THE BUILDING.
- THE OWNER SHALL PROVIDE ALL UTILITIES AND CONNECTIONS TO THE BUILDING. THE OWNER SHALL BE RESPONSIBLE FOR THE COST OF ALL UTILITIES AND CONNECTIONS TO THE BUILDING.
- THE OWNER SHALL PROVIDE ALL UTILITIES AND CONNECTIONS TO THE BUILDING. THE OWNER SHALL BE RESPONSIBLE FOR THE COST OF ALL UTILITIES AND CONNECTIONS TO THE BUILDING.
- THE OWNER SHALL PROVIDE ALL UTILITIES AND CONNECTIONS TO THE BUILDING. THE OWNER SHALL BE RESPONSIBLE FOR THE COST OF ALL UTILITIES AND CONNECTIONS TO THE BUILDING.
- THE OWNER SHALL PROVIDE ALL UTILITIES AND CONNECTIONS TO THE BUILDING. THE OWNER SHALL BE RESPONSIBLE FOR THE COST OF ALL UTILITIES AND CONNECTIONS TO THE BUILDING.
- THE OWNER SHALL PROVIDE ALL UTILITIES AND CONNECTIONS TO THE BUILDING. THE OWNER SHALL BE RESPONSIBLE FOR THE COST OF ALL UTILITIES AND CONNECTIONS TO THE BUILDING.
- THE OWNER SHALL PROVIDE ALL UTILITIES AND CONNECTIONS TO THE BUILDING. THE OWNER SHALL BE RESPONSIBLE FOR THE COST OF ALL UTILITIES AND CONNECTIONS TO THE BUILDING.
- THE OWNER SHALL PROVIDE ALL UTILITIES AND CONNECTIONS TO THE BUILDING. THE OWNER SHALL BE RESPONSIBLE FOR THE COST OF ALL UTILITIES AND CONNECTIONS TO THE BUILDING.

**Blair Church Flynn**

2021 PAVEMENT REHABILITATION  
VARIOUS SITES  
CLOVIS NORTH HIGH SCHOOL  
ACCESS COMPLIANCE PLAN

**CONST. DOCUMENTS**

**CN-2**

NORTH CHESTNUT AVENUE NORTH CHESTNUT AVENUE

EAST INTERNATIONAL AVENUE

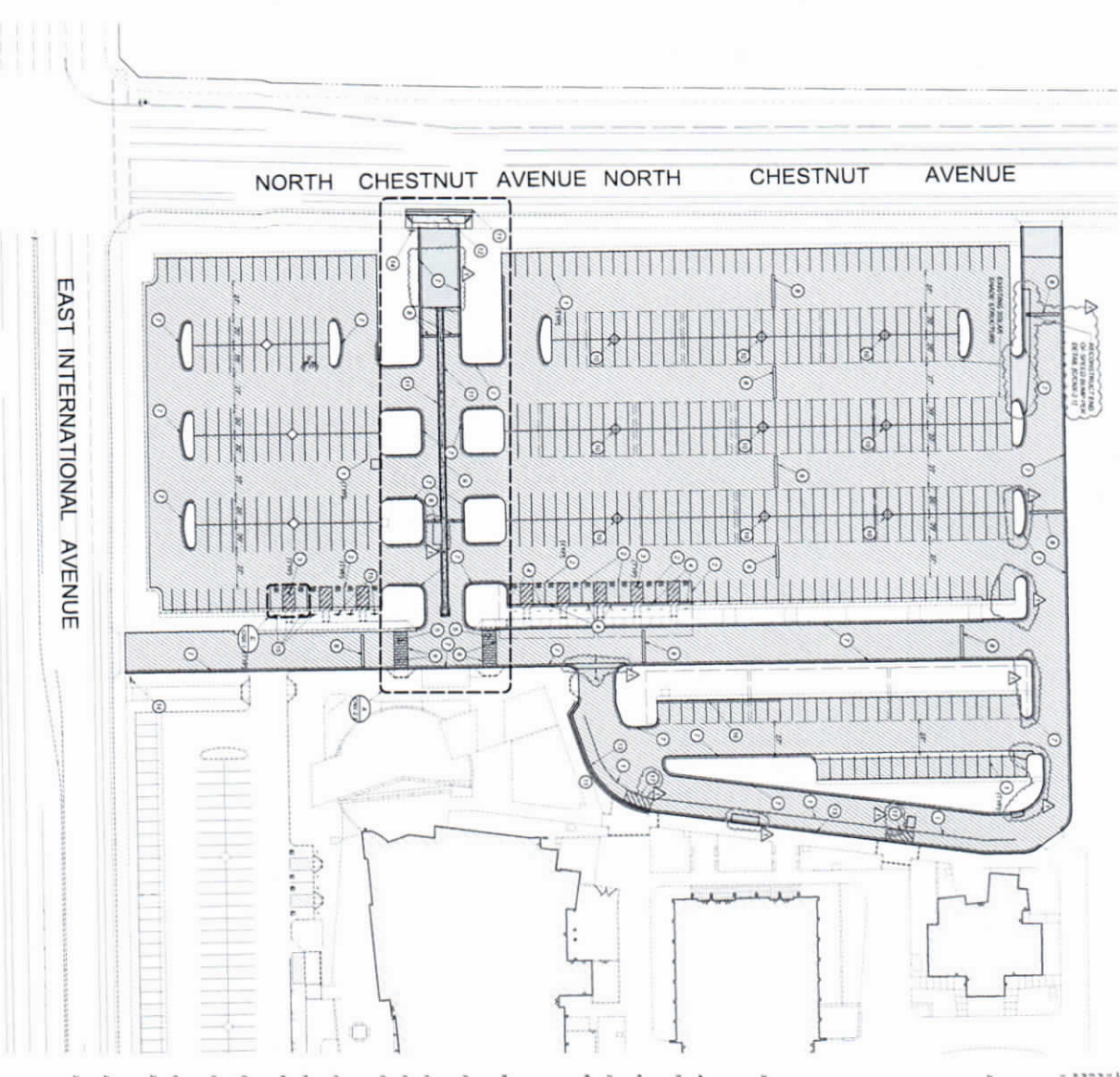

GENERAL NOTES:

1. THE CONTRACTOR SHALL MAINTAIN ACCESS TO ALL ADJACENT PROPERTIES AT ALL TIMES.
2. THE CONTRACTOR SHALL MAINTAIN ACCESS TO ALL ADJACENT PROPERTIES AT ALL TIMES.
3. THE CONTRACTOR SHALL MAINTAIN ACCESS TO ALL ADJACENT PROPERTIES AT ALL TIMES.
4. THE CONTRACTOR SHALL MAINTAIN ACCESS TO ALL ADJACENT PROPERTIES AT ALL TIMES.
5. THE CONTRACTOR SHALL MAINTAIN ACCESS TO ALL ADJACENT PROPERTIES AT ALL TIMES.
6. THE CONTRACTOR SHALL MAINTAIN ACCESS TO ALL ADJACENT PROPERTIES AT ALL TIMES.
7. THE CONTRACTOR SHALL MAINTAIN ACCESS TO ALL ADJACENT PROPERTIES AT ALL TIMES.
8. THE CONTRACTOR SHALL MAINTAIN ACCESS TO ALL ADJACENT PROPERTIES AT ALL TIMES.
9. THE CONTRACTOR SHALL MAINTAIN ACCESS TO ALL ADJACENT PROPERTIES AT ALL TIMES.
10. THE CONTRACTOR SHALL MAINTAIN ACCESS TO ALL ADJACENT PROPERTIES AT ALL TIMES.
11. THE CONTRACTOR SHALL MAINTAIN ACCESS TO ALL ADJACENT PROPERTIES AT ALL TIMES.
12. THE CONTRACTOR SHALL MAINTAIN ACCESS TO ALL ADJACENT PROPERTIES AT ALL TIMES.
13. THE CONTRACTOR SHALL MAINTAIN ACCESS TO ALL ADJACENT PROPERTIES AT ALL TIMES.
14. THE CONTRACTOR SHALL MAINTAIN ACCESS TO ALL ADJACENT PROPERTIES AT ALL TIMES.
15. THE CONTRACTOR SHALL MAINTAIN ACCESS TO ALL ADJACENT PROPERTIES AT ALL TIMES.
16. THE CONTRACTOR SHALL MAINTAIN ACCESS TO ALL ADJACENT PROPERTIES AT ALL TIMES.
17. THE CONTRACTOR SHALL MAINTAIN ACCESS TO ALL ADJACENT PROPERTIES AT ALL TIMES.
18. THE CONTRACTOR SHALL MAINTAIN ACCESS TO ALL ADJACENT PROPERTIES AT ALL TIMES.
19. THE CONTRACTOR SHALL MAINTAIN ACCESS TO ALL ADJACENT PROPERTIES AT ALL TIMES.
20. THE CONTRACTOR SHALL MAINTAIN ACCESS TO ALL ADJACENT PROPERTIES AT ALL TIMES.
21. THE CONTRACTOR SHALL MAINTAIN ACCESS TO ALL ADJACENT PROPERTIES AT ALL TIMES.
22. THE CONTRACTOR SHALL MAINTAIN ACCESS TO ALL ADJACENT PROPERTIES AT ALL TIMES.

CONSTRUCTION LEGEND:

- 1. EXISTING CURB
- 2. NEW CURB
- 3. EXISTING DRIVEWAY
- 4. NEW DRIVEWAY
- 5. EXISTING SIDEWALK
- 6. NEW SIDEWALK
- 7. EXISTING PAVEMENT
- 8. NEW PAVEMENT
- 9. EXISTING ASPHALT
- 10. NEW ASPHALT
- 11. EXISTING CONCRETE
- 12. NEW CONCRETE
- 13. EXISTING BRICK
- 14. NEW BRICK
- 15. EXISTING STONE
- 16. NEW STONE
- 17. EXISTING METAL
- 18. NEW METAL
- 19. EXISTING WOOD
- 20. NEW WOOD

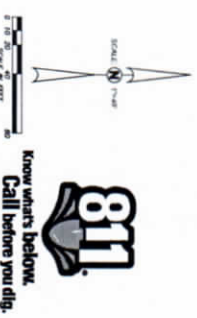

**Blair Church Gym**

2021 PAVEMENT REHABILITATION  
VARIOUS SITES  
CLOVIS NORTH HIGH SCHOOL  
SITE AND DIMENSION PLAN

CONSTRUCTION DOCUMENTS  
DATE: 02-11-2020  
DRAWN BY: [Name]

811 Know what's below. Call before you dig.

NOTE: 2" ASPHALT TO CONCRETE TYPE 8 WITH 12" WALL ADJACENT. 6" SOLOFORM TO BASE CLASS 2 SOIL STRIKER. 1" COMPACTED SOIL.

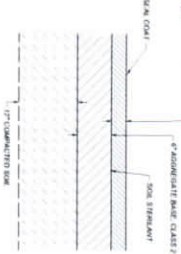

**A** ASPHALT TO CONCRETE PAVEMENT SECTION  
CNX-1 NOT TO SCALE

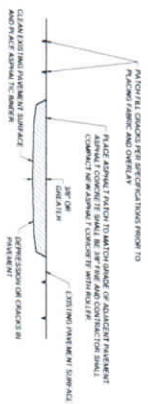

**B** CRACK PATCHING DETAIL  
CNX-1 NOT TO SCALE

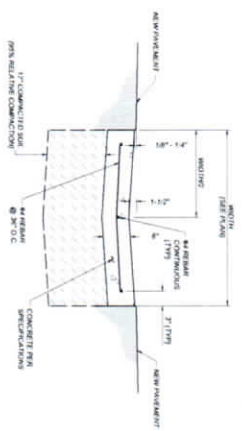

**C** CONCRETE VALLEY GUTTER  
CNX-1 NOT TO SCALE

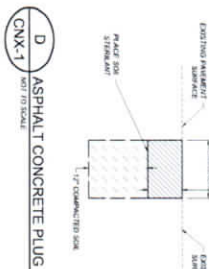

**D** ASPHALT TO CONCRETE PLUG  
CNX-1 NOT TO SCALE

FORM SHOWN ONLY  
APP. # 02-118050

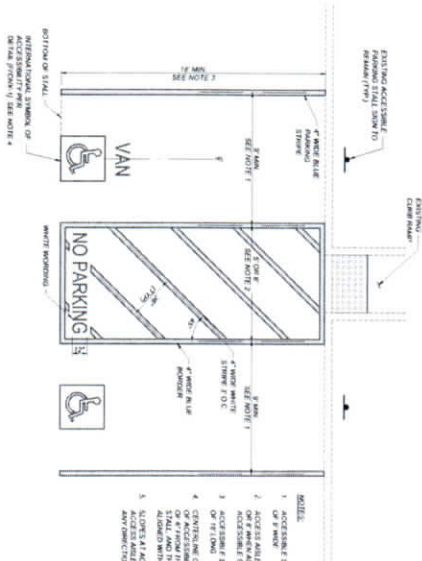

**E** TYPICAL ACCESSIBLE PARKING STALL DETAIL  
CNX-1 NOT TO SCALE

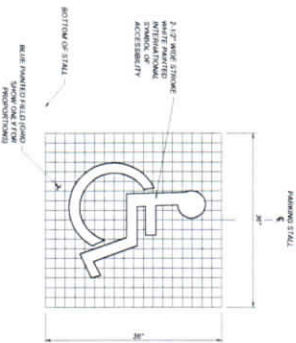

**F** ACCESSIBLE SYMBOL  
CNX-1 NOT TO SCALE

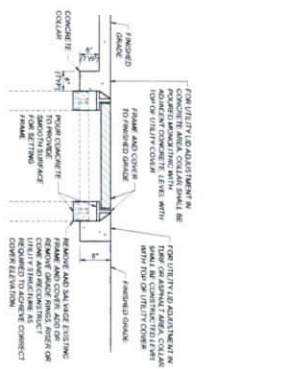

**G** ADJUST UTILITY LID  
CNX-1 NOT TO SCALE

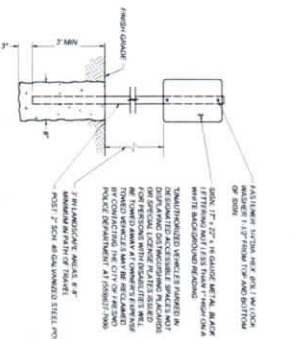

**H** ENTRY SIGN  
CNX-1 NOT TO SCALE

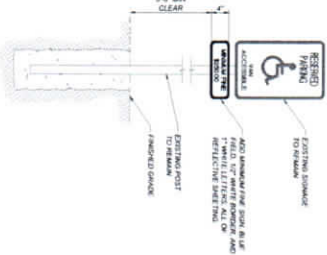

**I** UPDATE TO EXISTING ACCESSIBLE PARKING STALL SIGNAGE  
CNX-1 NOT TO SCALE

Blair Church Gymnasium  
CONSULTING ENGINEERS

CONSULTANT: Blair Church Gymnasium  
PROJECT: 2021 PAVEMENT REHABILITATION  
SHEET: 02A-01

CLAVIS UNIFIED SCHOOL DISTRICT  
2021 PAVEMENT REHABILITATION  
VARIOUS SITES  
CLAVIS NORTH HIGH SCHOOL  
DETAILS

CONST. DOCUMENTS  
CNX-1

NORTH CHESTNUT AVENUE

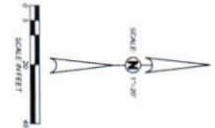
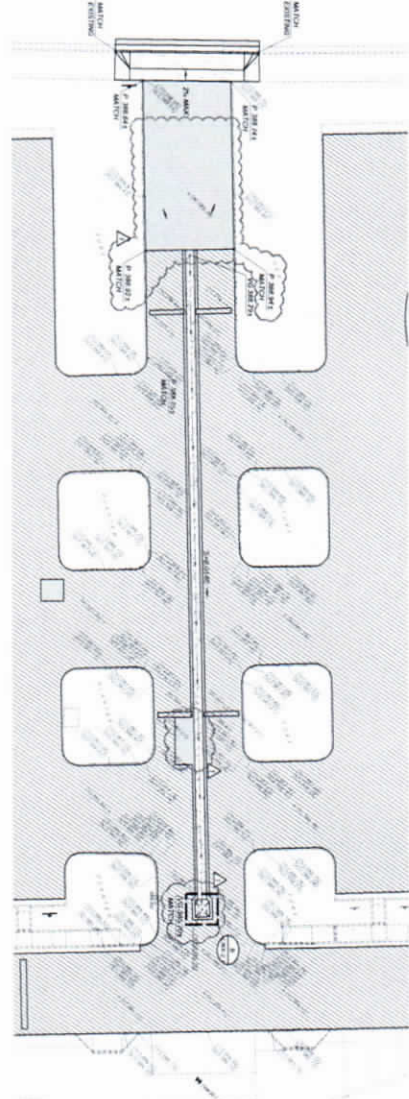

LEGEND

- ASPHALT PAVEMENT
- ASPHALT TO CONCRETE
- CONCRETE EDGE
- GRASS PAVEMENT
- GRASS
- TYPE OF CURB
- UTILITY CONTROL POINT
- CONCRETE IMPROVEMENTS
- CONCRETE
- FLASING AND DIRECTION
- ROAD
- SITE BENCHMARK

NOTE

THE SURVEYING ENGINEER HAS NOT CONDUCTED VISUAL INSPECTIONS OF THE SITE AND THE ELEVATION OF DETERMINED BENCHMARKS AT THE FIELD SITE MAY BE DIFFERENT FROM THE ELEVATION SHOWN ON THIS PLAN. THE ENGINEER SHALL CONDUCT VISUAL INSPECTIONS OF THE SITE AND DETERMINE THE LOCATION OF ALL BENCHMARKS AND THE ELEVATION OF ALL BENCHMARKS AT THE FIELD SITE.

SITE BENCHMARK

THE BENCHMARK IS LOCATED AT THE INTERSECTION OF NORTH CHESTNUT AVENUE AND THE EAST SIDE OF THE PARKING LOT. THE BENCHMARK IS A CONCRETE PILE WITH AN ELEVATION OF 100.00 FEET ABOVE MEAN SEA LEVEL.

UTILITY NOTE

ALL UTILITIES SHOWN ON THIS PLAN ARE BASED ON THE RECORD DRAWINGS AND FIELD SURVEY. THE ENGINEER HAS NOT CONDUCTED VISUAL INSPECTIONS OF THE SITE AND THE LOCATION OF UTILITIES MAY BE DIFFERENT FROM THE LOCATION SHOWN ON THIS PLAN. THE ENGINEER SHALL CONDUCT VISUAL INSPECTIONS OF THE SITE AND DETERMINE THE LOCATION OF ALL UTILITIES AT THE FIELD SITE.

GRADING LEGEND

- PAVEMENT
- NEW PAVED GRADE
- EXISTING GRADE
- DIRECTION OF DRAINAGE

GENERAL GRADING AND DRAINAGE NOTES:

1. THE ENGINEER HAS NOT CONDUCTED VISUAL INSPECTIONS OF THE SITE AND THE ELEVATION OF DETERMINED BENCHMARKS AT THE FIELD SITE MAY BE DIFFERENT FROM THE ELEVATION SHOWN ON THIS PLAN. THE ENGINEER SHALL CONDUCT VISUAL INSPECTIONS OF THE SITE AND DETERMINE THE LOCATION OF ALL BENCHMARKS AND THE ELEVATION OF ALL BENCHMARKS AT THE FIELD SITE.
2. THE ENGINEER HAS NOT CONDUCTED VISUAL INSPECTIONS OF THE SITE AND THE LOCATION OF UTILITIES MAY BE DIFFERENT FROM THE LOCATION SHOWN ON THIS PLAN. THE ENGINEER SHALL CONDUCT VISUAL INSPECTIONS OF THE SITE AND DETERMINE THE LOCATION OF ALL UTILITIES AT THE FIELD SITE.
3. THE ENGINEER HAS NOT CONDUCTED VISUAL INSPECTIONS OF THE SITE AND THE LOCATION OF UTILITIES MAY BE DIFFERENT FROM THE LOCATION SHOWN ON THIS PLAN. THE ENGINEER SHALL CONDUCT VISUAL INSPECTIONS OF THE SITE AND DETERMINE THE LOCATION OF ALL UTILITIES AT THE FIELD SITE.
4. THE ENGINEER HAS NOT CONDUCTED VISUAL INSPECTIONS OF THE SITE AND THE LOCATION OF UTILITIES MAY BE DIFFERENT FROM THE LOCATION SHOWN ON THIS PLAN. THE ENGINEER SHALL CONDUCT VISUAL INSPECTIONS OF THE SITE AND DETERMINE THE LOCATION OF ALL UTILITIES AT THE FIELD SITE.
5. THE ENGINEER HAS NOT CONDUCTED VISUAL INSPECTIONS OF THE SITE AND THE LOCATION OF UTILITIES MAY BE DIFFERENT FROM THE LOCATION SHOWN ON THIS PLAN. THE ENGINEER SHALL CONDUCT VISUAL INSPECTIONS OF THE SITE AND DETERMINE THE LOCATION OF ALL UTILITIES AT THE FIELD SITE.
6. THE ENGINEER HAS NOT CONDUCTED VISUAL INSPECTIONS OF THE SITE AND THE LOCATION OF UTILITIES MAY BE DIFFERENT FROM THE LOCATION SHOWN ON THIS PLAN. THE ENGINEER SHALL CONDUCT VISUAL INSPECTIONS OF THE SITE AND DETERMINE THE LOCATION OF ALL UTILITIES AT THE FIELD SITE.
7. THE ENGINEER HAS NOT CONDUCTED VISUAL INSPECTIONS OF THE SITE AND THE LOCATION OF UTILITIES MAY BE DIFFERENT FROM THE LOCATION SHOWN ON THIS PLAN. THE ENGINEER SHALL CONDUCT VISUAL INSPECTIONS OF THE SITE AND DETERMINE THE LOCATION OF ALL UTILITIES AT THE FIELD SITE.
8. THE ENGINEER HAS NOT CONDUCTED VISUAL INSPECTIONS OF THE SITE AND THE LOCATION OF UTILITIES MAY BE DIFFERENT FROM THE LOCATION SHOWN ON THIS PLAN. THE ENGINEER SHALL CONDUCT VISUAL INSPECTIONS OF THE SITE AND DETERMINE THE LOCATION OF ALL UTILITIES AT THE FIELD SITE.
9. THE ENGINEER HAS NOT CONDUCTED VISUAL INSPECTIONS OF THE SITE AND THE LOCATION OF UTILITIES MAY BE DIFFERENT FROM THE LOCATION SHOWN ON THIS PLAN. THE ENGINEER SHALL CONDUCT VISUAL INSPECTIONS OF THE SITE AND DETERMINE THE LOCATION OF ALL UTILITIES AT THE FIELD SITE.
10. THE ENGINEER HAS NOT CONDUCTED VISUAL INSPECTIONS OF THE SITE AND THE LOCATION OF UTILITIES MAY BE DIFFERENT FROM THE LOCATION SHOWN ON THIS PLAN. THE ENGINEER SHALL CONDUCT VISUAL INSPECTIONS OF THE SITE AND DETERMINE THE LOCATION OF ALL UTILITIES AT THE FIELD SITE.

A GRADING ENLARGEMENT AT PARKING LOT ENTRANCE

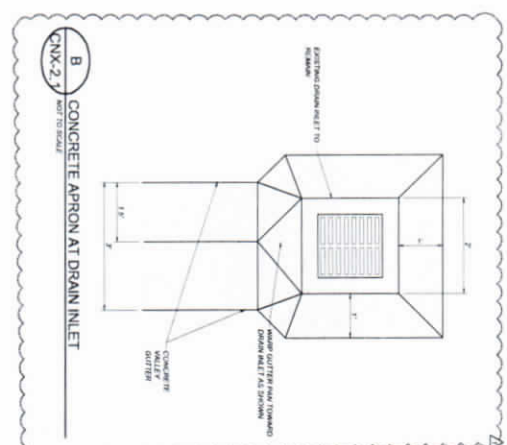

X SPEED BUMP

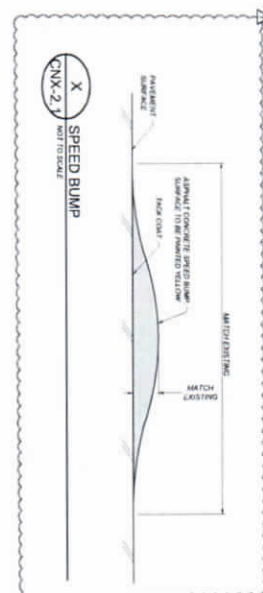

Blair Church Gymnasium  
2021 PAVEMENT REHABILITATION  
VARIOUS SITES  
CLOVIS NORTH HIGH SCHOOL  
DETAILS

CLOVIS UNIFIED SCHOOL DISTRICT

CONST. DOCUMENTS  
CNX-2

811  
Know what's Below.  
Call before you dig.

# CLOVIS UNIFIED SCHOOL DISTRICT

EIMEAR O'FARRELL, ED. D., DISTRICT SUPERINTENDENT

## PLANS FOR THE CONSTRUCTION OF 2021 PARKING LOT REHABILITATION IMPROVEMENTS AT CLOVIS WEST HIGH SCHOOL

FOR DISPLAY ONLY  
APP # 02-118054



**LOCATION MAP**  
NOT TO SCALE

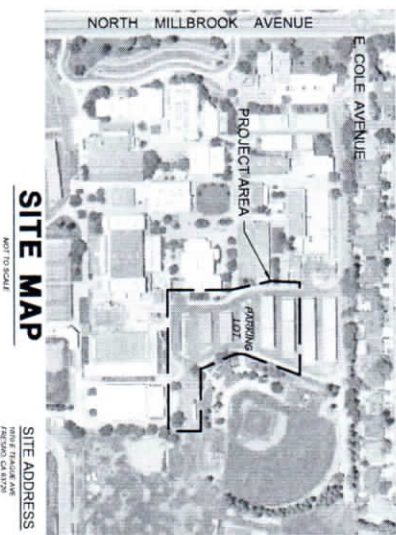

**SITE MAP**  
NOT TO SCALE

SITE ADDRESS  
FRESNO COUNTY

**PROJECT CONTACTS**

CLOVIS UNIFIED SCHOOL DISTRICT  
CLOVIS, CA 93611  
PHONE: (509) 227-8000  
FAX: (509) 227-8000  
BLAIR CHURCH & LYNN  
CONSULTING ENGINEERS  
811 CLOVIS AVE, SUITE 200  
FRESNO, CALIF 93701

**SCOPE OF WORK:**

1. REMOVE AND REPLACE DAMAGED ASPHALT CONCERTE PAVEMENT
2. RE-STRIP PARKING LOT AND INSTALL NEW ASPHALT CONCRETE SURFACE

**APPLICABLE CODES:**

- 2019 CALIFORNIA MODEL CODE, TITLE 24, PART 1, CODE
- 2019 CALIFORNIA MODEL CODE, TITLE 24, PART 2, CODE

**FLOOD HAZARD ZONE INFORMATION:**

1. FLOOD ZONE DESIGNATION: NONE
2. FLOOD HAZARD INFORMATION: NONE
3. FLOOD EFFECTIVE DATE: FEBRUARY 19, 2009
4. MAP: FLOOD ZONE MAP

**GENERAL NOTES:**

1. ALL WORK SHALL BE DONE IN ACCORDANCE WITH THE CONSTRUCTION PERMITS AND THE STATE OF CALIFORNIA STANDARD SPECIFICATIONS FOR PUBLIC WORKS.
2. THE CONTRACTOR SHALL COORDINATE ALL CONSTRUCTION ACTIVITIES WITH THE LOCAL AGENCIES AND THE STATE OF CALIFORNIA STANDARD SPECIFICATIONS FOR PUBLIC WORKS.
3. THE CONTRACTOR SHALL COORDINATE ALL CONSTRUCTION ACTIVITIES WITH THE LOCAL AGENCIES AND THE STATE OF CALIFORNIA STANDARD SPECIFICATIONS FOR PUBLIC WORKS.
4. THE CONTRACTOR SHALL COORDINATE ALL CONSTRUCTION ACTIVITIES WITH THE LOCAL AGENCIES AND THE STATE OF CALIFORNIA STANDARD SPECIFICATIONS FOR PUBLIC WORKS.
5. THE CONTRACTOR SHALL COORDINATE ALL CONSTRUCTION ACTIVITIES WITH THE LOCAL AGENCIES AND THE STATE OF CALIFORNIA STANDARD SPECIFICATIONS FOR PUBLIC WORKS.
6. THE CONTRACTOR SHALL COORDINATE ALL CONSTRUCTION ACTIVITIES WITH THE LOCAL AGENCIES AND THE STATE OF CALIFORNIA STANDARD SPECIFICATIONS FOR PUBLIC WORKS.
7. THE CONTRACTOR SHALL COORDINATE ALL CONSTRUCTION ACTIVITIES WITH THE LOCAL AGENCIES AND THE STATE OF CALIFORNIA STANDARD SPECIFICATIONS FOR PUBLIC WORKS.
8. THE CONTRACTOR SHALL COORDINATE ALL CONSTRUCTION ACTIVITIES WITH THE LOCAL AGENCIES AND THE STATE OF CALIFORNIA STANDARD SPECIFICATIONS FOR PUBLIC WORKS.
9. THE CONTRACTOR SHALL COORDINATE ALL CONSTRUCTION ACTIVITIES WITH THE LOCAL AGENCIES AND THE STATE OF CALIFORNIA STANDARD SPECIFICATIONS FOR PUBLIC WORKS.
10. THE CONTRACTOR SHALL COORDINATE ALL CONSTRUCTION ACTIVITIES WITH THE LOCAL AGENCIES AND THE STATE OF CALIFORNIA STANDARD SPECIFICATIONS FOR PUBLIC WORKS.

**811**  
Know what's below.  
Call before you dig.

CLOVIS UNIFIED SCHOOL DISTRICT

CONST. DOCUMENTS  
CW-1

**TABLE OF CONTENTS**

SHEET NUMBER	SHEET TITLE
CW-1	COVER SHEET
CW-2	ACCESS CONFORMANCE PLAN
CW-3	TEMPORARY AND DEMOLITION PLAN
CW-4	ERT AND DEMOLITION PLAN
CW-5	GRADING AND DRAINAGE PLAN
CW-6	DETAILS

TOTAL SHEET COUNT: 6



Blair Church & Lynn  
CONSULTING ENGINEERS



CONSULTANT  
ME & E  
CLOVIS, CA

2021 PARKING LOT REHABILITATION  
CLOVIS WEST HIGH SCHOOL  
COVER SHEET

CONS. DOCUMENTS  
CW-1





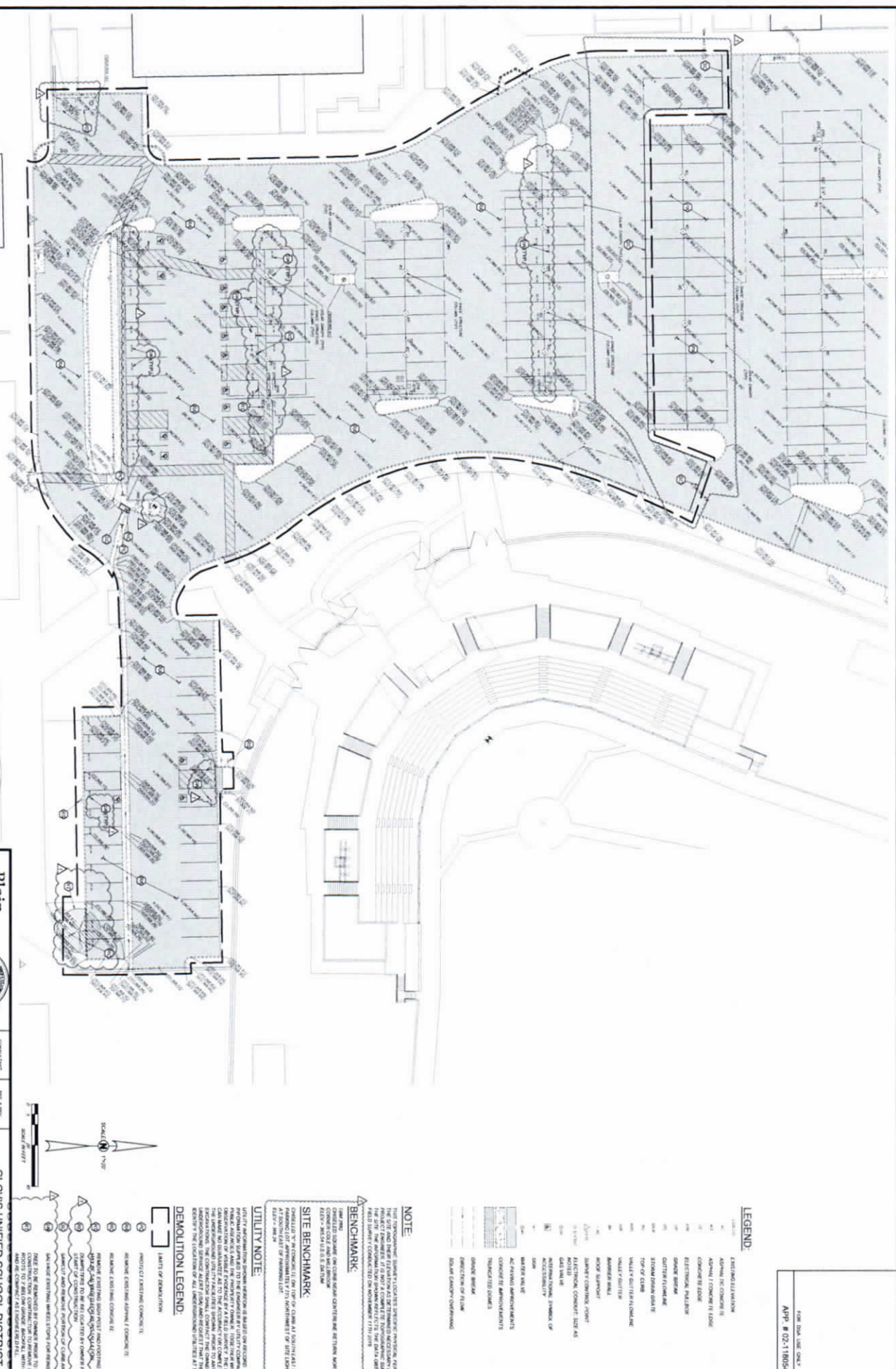

**LEGEND:**

- EXISTING ELEVATION
- ASPHALT (NO CONCRETE IS)
- CONCRETE FLOOR
- ELECTRICAL PANEL
- WOOD FLOORING
- STANDARD WOOD FLOORING
- TYPICAL WOOD FLOORING
- WALLS & CEILING
- ROOF STRUCTURE
- MECHANICAL ROOMS
- ELECTRICAL ROOMS
- WATER MAIN
- SEWER MAIN
- GAS MAIN
- ACCIDENTALS
- INSTRUMENTAL SYMBOLS OR
- ASPHALT PAVEMENT
- CONCRETE PAVEMENT
- TRANSFORMERS
- PAVED DRIVEWAYS
- PAVED SIDEWALKS
- PAVED CURBS
- PAVED PARKING
- PAVED DRIVEWAYS
- PAVED SIDEWALKS
- PAVED CURBS
- PAVED PARKING
- PAVED DRIVEWAYS
- PAVED SIDEWALKS
- PAVED CURBS
- PAVED PARKING
- PAVED DRIVEWAYS
- PAVED SIDEWALKS
- PAVED CURBS
- PAVED PARKING

**NOTE:**  
 THIS TOPOGRAPHIC SURVEY LOCATES THE EXISTING PHYSICAL FEATURES OF THE SITE AND PROVIDES THE ELEVATIONS OF THE SURFACE AND SUBSURFACE OF THE SITE. THE SURFACE ELEVATIONS ARE GIVEN IN FEET ABOVE MEAN SEA LEVEL. THE SUBSURFACE ELEVATIONS ARE GIVEN IN FEET ABOVE MEAN SEA LEVEL.

**SITE BENCHMARK:**  
 CHECKED BY: ENGINEER, DATE: 11/15/2021, OR CIVIL ENGINEER AS SHOWN ON SHEET "A" OF THIS DRAWING SET.

**BENCHMARK:**  
 THE BENCHMARK IS A 6\"/>

**UTILITY NOTE:**  
 THE LOCATION OF ALL UTILITIES SHOWN ON THIS PLAN IS BASED ON RECORD DRAWINGS, FIELD SURVEY, AND OTHER AVAILABLE INFORMATION. THE CONTRACTOR SHALL VERIFY THE LOCATION AND DEPTH OF ALL UTILITIES PRIOR TO CONSTRUCTION.

**DEMOLITION LEGEND:**

- REMOVAL OF EXISTING CONCRETE
- REMOVAL OF EXISTING ASPHALT
- REMOVAL OF EXISTING WOOD FLOORING
- REMOVAL OF EXISTING WALLS & CEILING
- REMOVAL OF EXISTING ROOF STRUCTURE
- REMOVAL OF EXISTING MECHANICAL ROOMS
- REMOVAL OF EXISTING ELECTRICAL ROOMS
- REMOVAL OF EXISTING DRIVEWAYS
- REMOVAL OF EXISTING SIDEWALKS
- REMOVAL OF EXISTING CURBS
- REMOVAL OF EXISTING PARKING
- REMOVAL OF EXISTING DRIVEWAYS
- REMOVAL OF EXISTING SIDEWALKS
- REMOVAL OF EXISTING CURBS
- REMOVAL OF EXISTING PARKING

Blair Church Flynn  
 CONSULTANT

2021 PAVEMENT REHABILITATION  
 CLOVIS WEST HIGH SCHOOL  
 TOPOGRAPHIC & DEMOLITION PLAN

CLOVIS UNIFIED SCHOOL DISTRICT  
 CONST. DOCUMENTS  
 SHEET: CW-3.1

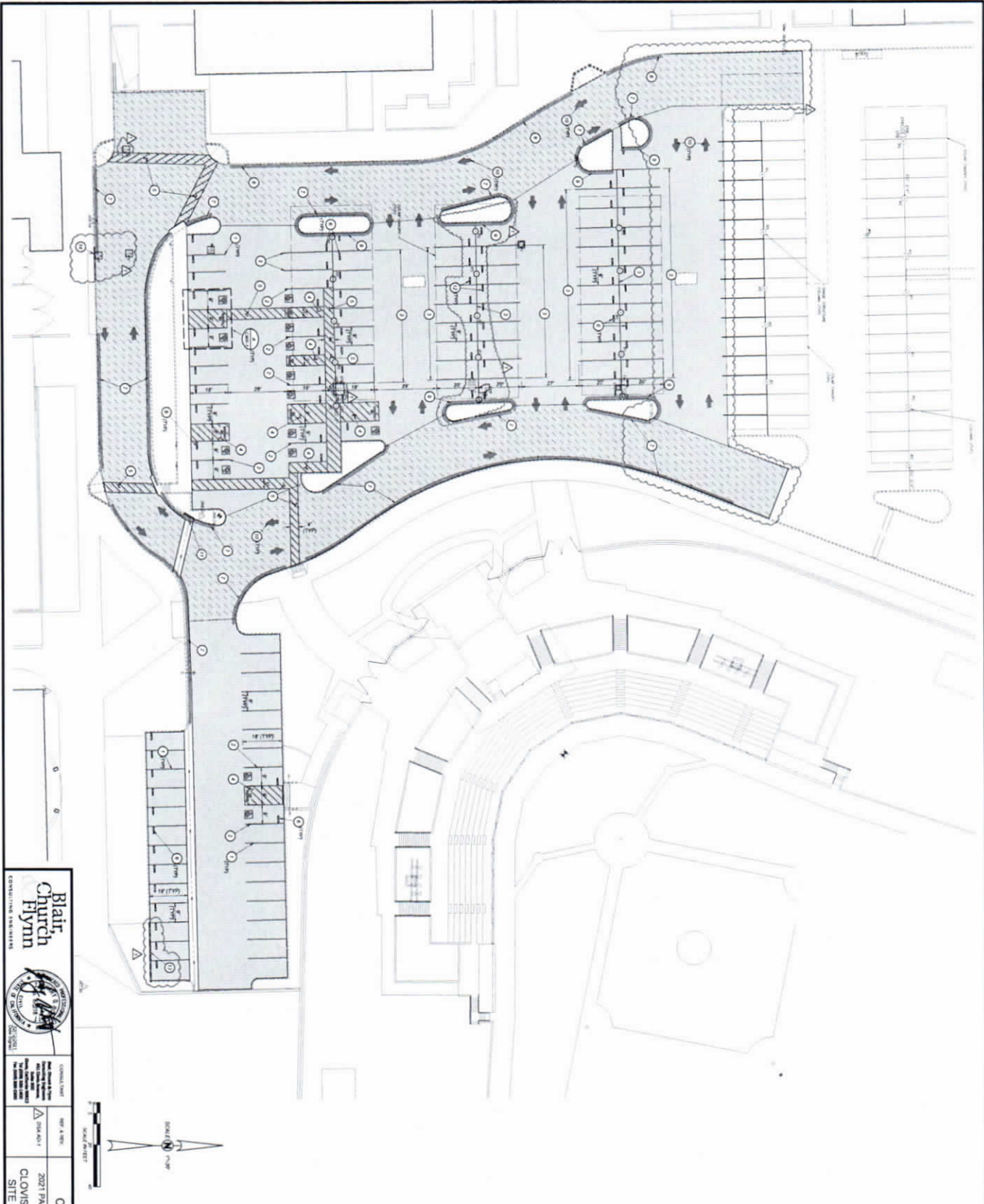

Blair Church Flynn Consulting Engineers

2021 PAVEMENT REHABILITATION VARIOUS SITES CLOVIS WEST HIGH SCHOOL SITE & DIMENSION PLAN

CONST. DOCUMENTS CW-4.1

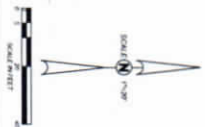

**CONSTRUCTION LEGEND**

- 1. DETAIL REVISIONS
- 2. SHEET LOCATION
- 3. LIMITS OF ASPHALT CONCRETE PAVEMENT REHABILITATION
- 4. LIMITS OF READY MIX ASPHALT CONCRETE PAVEMENT
- 5. LIMITS OF 2" SAND/AGG/10% CONCRETE
- 6. LIMITS OF 4" READY MIX CONCRETE
- 7. LIMITS OF 8" READY MIX CONCRETE
- 8. LIMITS OF 12" READY MIX CONCRETE
- 9. LIMITS OF 16" READY MIX CONCRETE
- 10. LIMITS OF 20" READY MIX CONCRETE
- 11. LIMITS OF 24" READY MIX CONCRETE
- 12. LIMITS OF 28" READY MIX CONCRETE
- 13. LIMITS OF 32" READY MIX CONCRETE
- 14. LIMITS OF 36" READY MIX CONCRETE
- 15. LIMITS OF 40" READY MIX CONCRETE
- 16. LIMITS OF 44" READY MIX CONCRETE
- 17. LIMITS OF 48" READY MIX CONCRETE
- 18. LIMITS OF 52" READY MIX CONCRETE
- 19. LIMITS OF 56" READY MIX CONCRETE
- 20. LIMITS OF 60" READY MIX CONCRETE
- 21. LIMITS OF 64" READY MIX CONCRETE
- 22. LIMITS OF 68" READY MIX CONCRETE
- 23. LIMITS OF 72" READY MIX CONCRETE
- 24. LIMITS OF 76" READY MIX CONCRETE
- 25. LIMITS OF 80" READY MIX CONCRETE
- 26. LIMITS OF 84" READY MIX CONCRETE
- 27. LIMITS OF 88" READY MIX CONCRETE
- 28. LIMITS OF 92" READY MIX CONCRETE
- 29. LIMITS OF 96" READY MIX CONCRETE
- 30. LIMITS OF 100" READY MIX CONCRETE

**GENERAL NOTES**

1. ALL EXISTING PAVING AND CONCRETE TO BE REHABILITATED SHALL BE REHABILITATED TO ORIGINAL FINISH ELEVATION UNLESS OTHERWISE NOTED.
2. ALL EXISTING PAVING AND CONCRETE TO BE REHABILITATED SHALL BE REHABILITATED TO ORIGINAL FINISH ELEVATION UNLESS OTHERWISE NOTED.
3. ALL EXISTING PAVING AND CONCRETE TO BE REHABILITATED SHALL BE REHABILITATED TO ORIGINAL FINISH ELEVATION UNLESS OTHERWISE NOTED.
4. ALL EXISTING PAVING AND CONCRETE TO BE REHABILITATED SHALL BE REHABILITATED TO ORIGINAL FINISH ELEVATION UNLESS OTHERWISE NOTED.
5. ALL EXISTING PAVING AND CONCRETE TO BE REHABILITATED SHALL BE REHABILITATED TO ORIGINAL FINISH ELEVATION UNLESS OTHERWISE NOTED.
6. ALL EXISTING PAVING AND CONCRETE TO BE REHABILITATED SHALL BE REHABILITATED TO ORIGINAL FINISH ELEVATION UNLESS OTHERWISE NOTED.
7. ALL EXISTING PAVING AND CONCRETE TO BE REHABILITATED SHALL BE REHABILITATED TO ORIGINAL FINISH ELEVATION UNLESS OTHERWISE NOTED.
8. ALL EXISTING PAVING AND CONCRETE TO BE REHABILITATED SHALL BE REHABILITATED TO ORIGINAL FINISH ELEVATION UNLESS OTHERWISE NOTED.
9. ALL EXISTING PAVING AND CONCRETE TO BE REHABILITATED SHALL BE REHABILITATED TO ORIGINAL FINISH ELEVATION UNLESS OTHERWISE NOTED.
10. ALL EXISTING PAVING AND CONCRETE TO BE REHABILITATED SHALL BE REHABILITATED TO ORIGINAL FINISH ELEVATION UNLESS OTHERWISE NOTED.
11. ALL EXISTING PAVING AND CONCRETE TO BE REHABILITATED SHALL BE REHABILITATED TO ORIGINAL FINISH ELEVATION UNLESS OTHERWISE NOTED.
12. ALL EXISTING PAVING AND CONCRETE TO BE REHABILITATED SHALL BE REHABILITATED TO ORIGINAL FINISH ELEVATION UNLESS OTHERWISE NOTED.
13. ALL EXISTING PAVING AND CONCRETE TO BE REHABILITATED SHALL BE REHABILITATED TO ORIGINAL FINISH ELEVATION UNLESS OTHERWISE NOTED.
14. ALL EXISTING PAVING AND CONCRETE TO BE REHABILITATED SHALL BE REHABILITATED TO ORIGINAL FINISH ELEVATION UNLESS OTHERWISE NOTED.
15. ALL EXISTING PAVING AND CONCRETE TO BE REHABILITATED SHALL BE REHABILITATED TO ORIGINAL FINISH ELEVATION UNLESS OTHERWISE NOTED.
16. ALL EXISTING PAVING AND CONCRETE TO BE REHABILITATED SHALL BE REHABILITATED TO ORIGINAL FINISH ELEVATION UNLESS OTHERWISE NOTED.
17. ALL EXISTING PAVING AND CONCRETE TO BE REHABILITATED SHALL BE REHABILITATED TO ORIGINAL FINISH ELEVATION UNLESS OTHERWISE NOTED.
18. ALL EXISTING PAVING AND CONCRETE TO BE REHABILITATED SHALL BE REHABILITATED TO ORIGINAL FINISH ELEVATION UNLESS OTHERWISE NOTED.
19. ALL EXISTING PAVING AND CONCRETE TO BE REHABILITATED SHALL BE REHABILITATED TO ORIGINAL FINISH ELEVATION UNLESS OTHERWISE NOTED.
20. ALL EXISTING PAVING AND CONCRETE TO BE REHABILITATED SHALL BE REHABILITATED TO ORIGINAL FINISH ELEVATION UNLESS OTHERWISE NOTED.
21. ALL EXISTING PAVING AND CONCRETE TO BE REHABILITATED SHALL BE REHABILITATED TO ORIGINAL FINISH ELEVATION UNLESS OTHERWISE NOTED.
22. ALL EXISTING PAVING AND CONCRETE TO BE REHABILITATED SHALL BE REHABILITATED TO ORIGINAL FINISH ELEVATION UNLESS OTHERWISE NOTED.
23. ALL EXISTING PAVING AND CONCRETE TO BE REHABILITATED SHALL BE REHABILITATED TO ORIGINAL FINISH ELEVATION UNLESS OTHERWISE NOTED.
24. ALL EXISTING PAVING AND CONCRETE TO BE REHABILITATED SHALL BE REHABILITATED TO ORIGINAL FINISH ELEVATION UNLESS OTHERWISE NOTED.
25. ALL EXISTING PAVING AND CONCRETE TO BE REHABILITATED SHALL BE REHABILITATED TO ORIGINAL FINISH ELEVATION UNLESS OTHERWISE NOTED.
26. ALL EXISTING PAVING AND CONCRETE TO BE REHABILITATED SHALL BE REHABILITATED TO ORIGINAL FINISH ELEVATION UNLESS OTHERWISE NOTED.
27. ALL EXISTING PAVING AND CONCRETE TO BE REHABILITATED SHALL BE REHABILITATED TO ORIGINAL FINISH ELEVATION UNLESS OTHERWISE NOTED.
28. ALL EXISTING PAVING AND CONCRETE TO BE REHABILITATED SHALL BE REHABILITATED TO ORIGINAL FINISH ELEVATION UNLESS OTHERWISE NOTED.
29. ALL EXISTING PAVING AND CONCRETE TO BE REHABILITATED SHALL BE REHABILITATED TO ORIGINAL FINISH ELEVATION UNLESS OTHERWISE NOTED.
30. ALL EXISTING PAVING AND CONCRETE TO BE REHABILITATED SHALL BE REHABILITATED TO ORIGINAL FINISH ELEVATION UNLESS OTHERWISE NOTED.



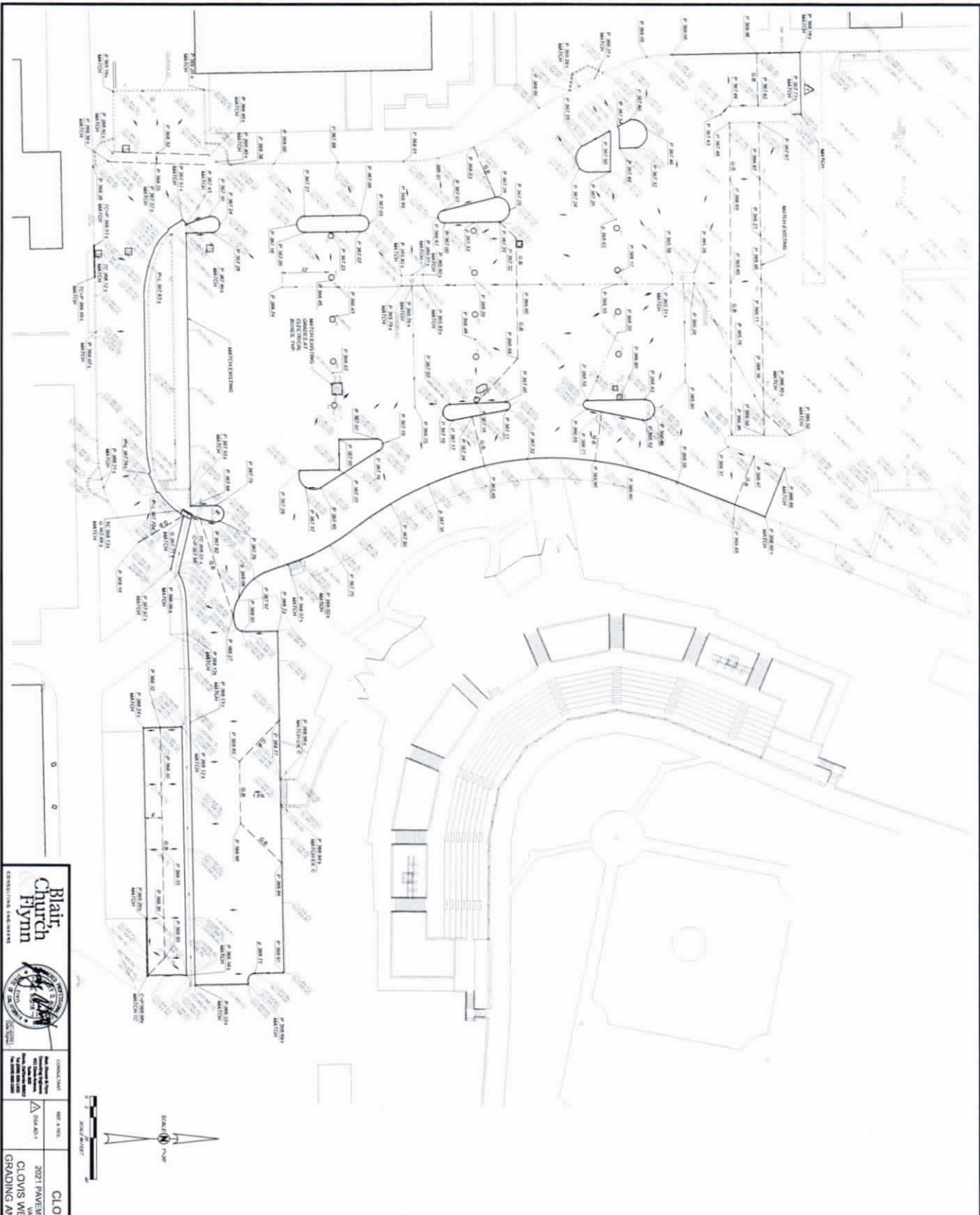

**Blair Church Flynn**  
CONSTRUCTION PERMITS



CONTRACT NO. 2021-1001  
SHEET NO. 1 OF 1  
DATE: 08/11/2021

**811**  
Know what's below.  
Call before you dig.

**CLOVIS UNIFIED SCHOOL DISTRICT**  
2021 PAVEMENT REHABILITATION  
VARIOUS SITES  
CLOVIS WEST HIGH SCHOOL  
GRADING AND DRAINAGE PLAN  
CONST. DOCUMENTS  
CW-5.1

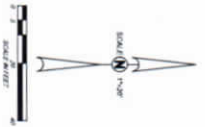

**GRADING LEGEND:**

0	WATER
1	PAVEMENT
2	TOP OF CURB
3	EXISTING ELEVATION
4	NEW PROPOSED ELEVATION
5	DIRECTION OF DRAINAGE
6	SHADE BOUNDARY
7	SMALL

**GENERAL GRADING AND DRAINAGE NOTES:**

1. THE EXISTING ELEVATIONS AND ANNOTATIONS SET OUT BELOW ARE PROVIDED FOR INFORMATION ONLY. THE EXISTING ELEVATIONS AND ANNOTATIONS SHALL BE VERIFIED BY THE CONTRACTOR PRIOR TO THE START OF CONSTRUCTION. THE CONTRACTOR SHALL BE RESPONSIBLE FOR OBTAINING ALL NECESSARY PERMITS AND APPROVALS FROM THE CITY OF CLOVIS AND THE STATE OF CALIFORNIA.
2. THE CONTRACTOR SHALL BE RESPONSIBLE FOR OBTAINING ALL NECESSARY PERMITS AND APPROVALS FROM THE CITY OF CLOVIS AND THE STATE OF CALIFORNIA.
3. THE CONTRACTOR SHALL BE RESPONSIBLE FOR OBTAINING ALL NECESSARY PERMITS AND APPROVALS FROM THE CITY OF CLOVIS AND THE STATE OF CALIFORNIA.
4. THE CONTRACTOR SHALL BE RESPONSIBLE FOR OBTAINING ALL NECESSARY PERMITS AND APPROVALS FROM THE CITY OF CLOVIS AND THE STATE OF CALIFORNIA.
5. THE CONTRACTOR SHALL BE RESPONSIBLE FOR OBTAINING ALL NECESSARY PERMITS AND APPROVALS FROM THE CITY OF CLOVIS AND THE STATE OF CALIFORNIA.
6. THE CONTRACTOR SHALL BE RESPONSIBLE FOR OBTAINING ALL NECESSARY PERMITS AND APPROVALS FROM THE CITY OF CLOVIS AND THE STATE OF CALIFORNIA.
7. THE CONTRACTOR SHALL BE RESPONSIBLE FOR OBTAINING ALL NECESSARY PERMITS AND APPROVALS FROM THE CITY OF CLOVIS AND THE STATE OF CALIFORNIA.
8. THE CONTRACTOR SHALL BE RESPONSIBLE FOR OBTAINING ALL NECESSARY PERMITS AND APPROVALS FROM THE CITY OF CLOVIS AND THE STATE OF CALIFORNIA.
9. THE CONTRACTOR SHALL BE RESPONSIBLE FOR OBTAINING ALL NECESSARY PERMITS AND APPROVALS FROM THE CITY OF CLOVIS AND THE STATE OF CALIFORNIA.
10. THE CONTRACTOR SHALL BE RESPONSIBLE FOR OBTAINING ALL NECESSARY PERMITS AND APPROVALS FROM THE CITY OF CLOVIS AND THE STATE OF CALIFORNIA.

100% SCALE (SEE SHEET)  
APP. # 02-118004

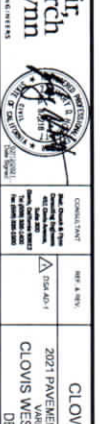
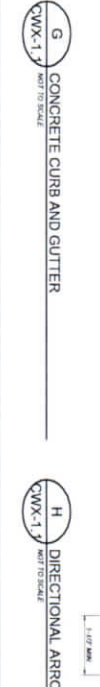
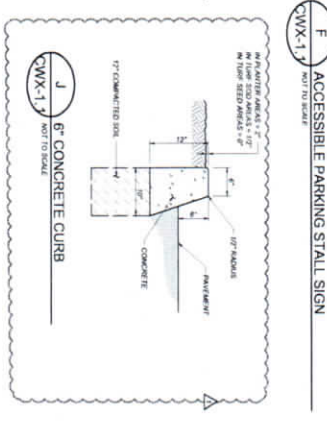
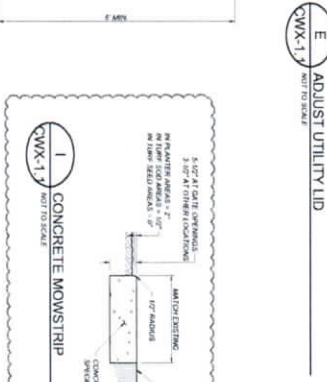
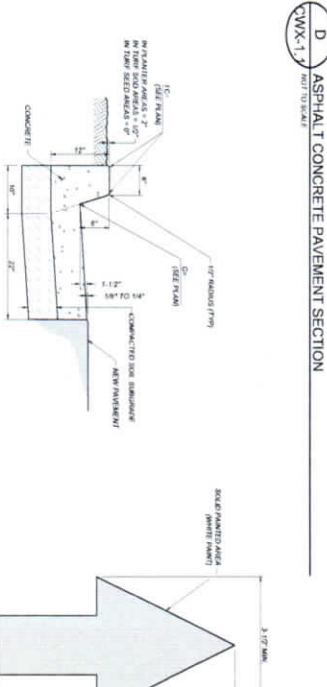
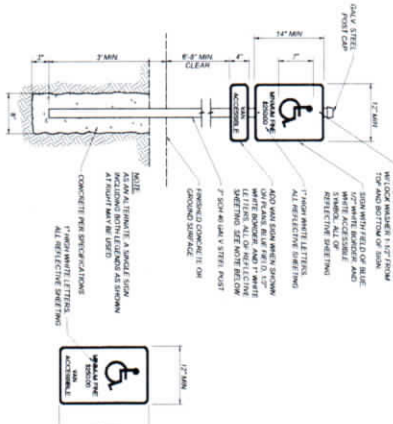
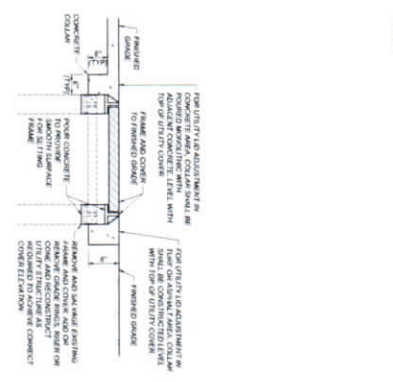
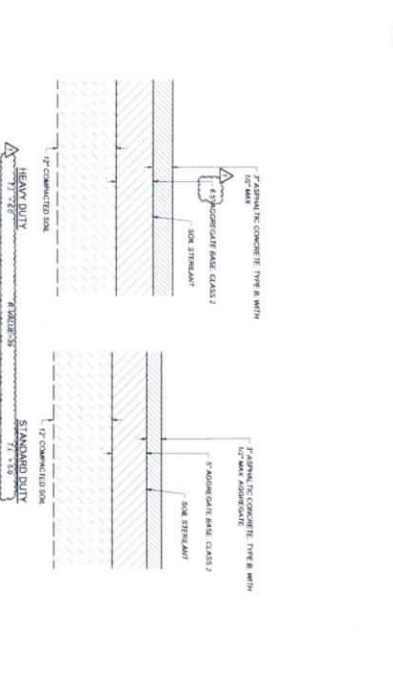
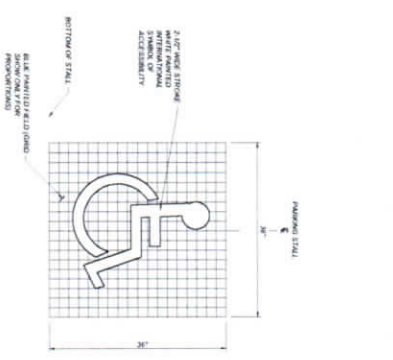
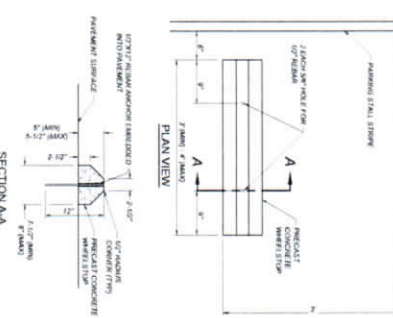
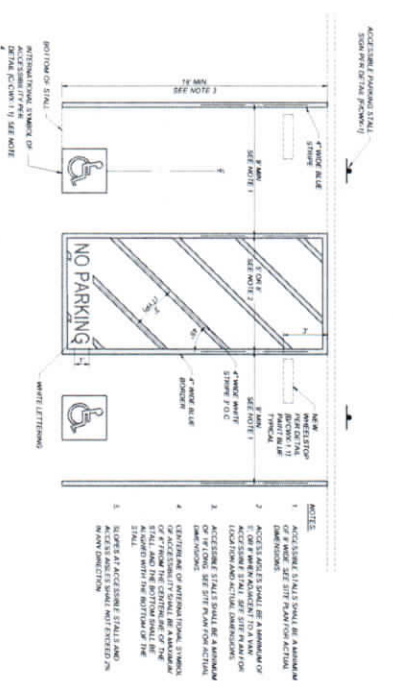

# CLOVIS UNIFIED SCHOOL DISTRICT ELMIEAR O'FARRELL, ED. D., DISTRICT SUPERINTENDENT PLANS FOR THE CONSTRUCTION OF 2021 PARKING LOT AND PLAYCOURT REHABILITATION IMPROVEMENTS AT COPPER HILLS ELEMENTARY SCHOOL

FORM NO. 108 (06/14)  
APP. # 02.118055



**LOCATION MAP**  
NOT TO SCALE

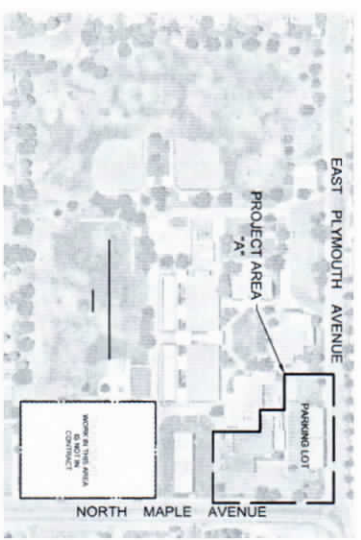

**SITE MAP**  
NOT TO SCALE

ADDRESS  
1811 E. PLYMOUTH AVE  
CLOVIS, CA 93611

**PROJECT CONTACTS:**

**OWNER:**  
CLOVIS UNIFIED SCHOOL DISTRICT  
1811 E. PLYMOUTH AVE  
CLOVIS, CA 93611  
PHONE: (559) 237-8800

**CONS ENGINEER:**  
BLAIR CHURCH FLYNN  
611 COLLEGE AVE  
CLOVIS, CA 93611  
PHONE: (559) 292-1881

**SCOPE OF WORK:**

1. REMOVE AND REPLACE EXISTING ON-SITE COMPACT ASPHALT PAVING AND
2. CONCRETE AND SEAL COT ASPHALT PAVEMENT AT PARKING
3. LOT AND PLAYCOURT
4. RE-STRIP PARKING LOT AND PLAYCOURT

**APPLICABLE CODES:**

- 2018 CALIFORNIA BUILDING CODE, TITLE 24, PART 1.10.01
- FLOOD HAZARD ZONE INFORMATION:**
- |                               |                                     |
|-------------------------------|-------------------------------------|
| 1. FLOOD ZONE DESIGNATION     | ZONE 4 AREA OF SPECIAL FLOOD HAZARD |
| 2. FLOOD PANEL IDENTIFICATION | AMP 4 (RIVERSIDE)                   |
| 3. FLOOD EFFECTIVE DATE       | FEBRUARY 18, 2006                   |
| 4. MAP FLOOD ELEVATION        | 100'                                |

**GENERAL NOTES:**

1. ALL WORK SHALL BE DONE IN ACCORDANCE WITH THE CONSTRUCTION CITY ESTABLISHED AND THE STATE OF CALIFORNIA STANDARD SPECIFICATIONS.
2. THE CONTRACTOR SHALL COORDINATE ALL CONSTRUCTION ACTIVITIES WITH THE SCHOOL DISTRICT'S SIZE OF THE PROJECT AND OTHER CONTRACTORS WHO MAY BE WORKING ON THE PROJECT.
3. THE CONTRACTOR SHALL CONSULT DISTRICT PERSONNEL FOR INFORMATION ON PROJECT SITE.
4. BEFORE COMMENCING WORK, THE CONTRACTOR SHALL NOTIFY ALL UTILITIES OF THE PROJECT AND SHALL VERIFY THE LOCATION AND DEPTH OF ALL UTILITIES TO BE PROTECTED OR MOVED. ANY UTILITY IS AT THE CONTRACTOR'S RISK TO BE DAMAGED FROM ANY WORK PERFORMED AT THE PROJECT SITE.
5. ALL CONSTRUCTION SHALL COMPLY TO THE REQUIREMENTS OF THE 2018 CALIFORNIA BUILDING CODE (CBC).
6. CONDUITS TO THE APPROVED CANNALS AND STRUCTURES SHALL BE MADE BY ACCORDANCE WITH SECTION 4.04, PART 1, TITLE 24, CBC.
7. A TYPICAL REPAIR CLASS 3 PROJECT PROJECTING THE DISTRICT THE WORK SHALL BE DONE IN ACCORDANCE WITH SECTION 4.04, PART 1, TITLE 24, CBC.
8. ALL WORK SHALL BE DONE IN ACCORDANCE WITH THE DISTRICT PROJECT.
9. THE OWNER OF THE DISTRICT AND SUPERVISOR SHALL HAVE THE RIGHT OF THE WORK WITHIN THE WORK. THE CONTRACTOR SHALL BE RESPONSIBLE FOR THE PROTECTION OF THE DISTRICT'S PROPERTY AND THE DISTRICT'S PROPERTY SHALL BE PROTECTED BY THE CONTRACTOR. THE CONTRACTOR SHALL BE RESPONSIBLE FOR THE PROTECTION OF THE DISTRICT'S PROPERTY AND THE DISTRICT'S PROPERTY SHALL BE PROTECTED BY THE CONTRACTOR.
10. THE CONTRACTOR SHALL BE RESPONSIBLE FOR THE PROTECTION OF THE DISTRICT'S PROPERTY AND THE DISTRICT'S PROPERTY SHALL BE PROTECTED BY THE CONTRACTOR.
11. THE CONTRACTOR SHALL BE RESPONSIBLE FOR THE PROTECTION OF THE DISTRICT'S PROPERTY AND THE DISTRICT'S PROPERTY SHALL BE PROTECTED BY THE CONTRACTOR.
12. THE CONTRACTOR SHALL BE RESPONSIBLE FOR THE PROTECTION OF THE DISTRICT'S PROPERTY AND THE DISTRICT'S PROPERTY SHALL BE PROTECTED BY THE CONTRACTOR.

**TABLE OF CONTENTS**

SHEET NUMBER	SHEET TITLE
CH-1	COVER SHEET
CH-2	ACCESS CONFORMANCE PLAN
CH-3	PARTIAL SITE & GRADING PLAN
CH-4	PARTIAL SITE & GRADING PLAN
CH-5	BITUMEN
CH-6	PLAYCOURT DETAILS
TOTAL SHEET COUNT: 6	



**NOTE: BID PACKAGE NOTES IN RED ISSUED BY BCF 3/6/2021**



CLOVIS UNIFIED SCHOOL DISTRICT  
2021 PARKING LOT AND PLAYCOURT REHABILITATION  
COPPER HILLS ELEMENTARY SCHOOL  
COVER SHEET



CONST. DOCUMENTS  
CH-1

E. PLYMOUTH AVENUE

N. MAPLE AVENUE

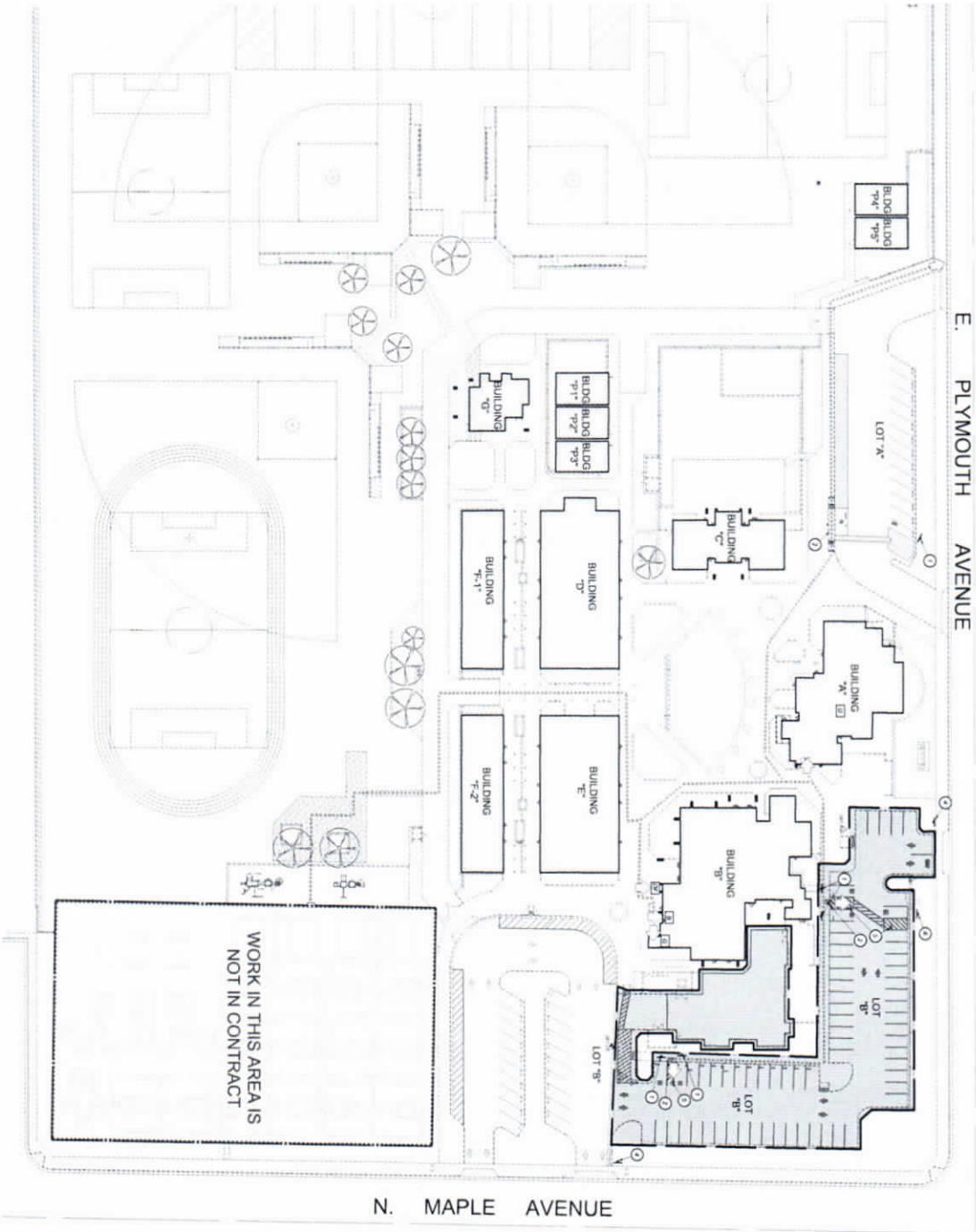

WORK IN THIS AREA  
NOT IN CONTRACT

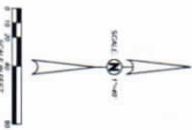

**PARKING CALCULATIONS**

ITEM	QUANTITY	STANDARD	STANDARD TOTAL
1. VISITORS	1	1	1
2. VISITORS	1	1	1
3. VISITORS	1	1	1
4. VISITORS	1	1	1
5. VISITORS	1	1	1
6. VISITORS	1	1	1
7. VISITORS	1	1	1
8. VISITORS	1	1	1
9. VISITORS	1	1	1
10. VISITORS	1	1	1
11. VISITORS	1	1	1
12. VISITORS	1	1	1
13. VISITORS	1	1	1
14. VISITORS	1	1	1
15. VISITORS	1	1	1
16. VISITORS	1	1	1
17. VISITORS	1	1	1
18. VISITORS	1	1	1
19. VISITORS	1	1	1
20. VISITORS	1	1	1
21. VISITORS	1	1	1
22. VISITORS	1	1	1
23. VISITORS	1	1	1
24. VISITORS	1	1	1
25. VISITORS	1	1	1
26. VISITORS	1	1	1
27. VISITORS	1	1	1
28. VISITORS	1	1	1
29. VISITORS	1	1	1
30. VISITORS	1	1	1
31. VISITORS	1	1	1
32. VISITORS	1	1	1
33. VISITORS	1	1	1
34. VISITORS	1	1	1
35. VISITORS	1	1	1
36. VISITORS	1	1	1
37. VISITORS	1	1	1
38. VISITORS	1	1	1
39. VISITORS	1	1	1
40. VISITORS	1	1	1
41. VISITORS	1	1	1
42. VISITORS	1	1	1
43. VISITORS	1	1	1
44. VISITORS	1	1	1
45. VISITORS	1	1	1
46. VISITORS	1	1	1
47. VISITORS	1	1	1
48. VISITORS	1	1	1
49. VISITORS	1	1	1
50. VISITORS	1	1	1

**BUILDING LEGEND**

ITEM	DESCRIPTION	QUANTITY
1	ADMINISTRATIVE	1
2	CLASSROOM	1
3	CLASSROOM	1
4	CLASSROOM	1
5	CLASSROOM	1
6	CLASSROOM	1
7	CLASSROOM	1
8	CLASSROOM	1
9	CLASSROOM	1
10	CLASSROOM	1
11	CLASSROOM	1
12	CLASSROOM	1
13	CLASSROOM	1
14	CLASSROOM	1
15	CLASSROOM	1
16	CLASSROOM	1
17	CLASSROOM	1
18	CLASSROOM	1
19	CLASSROOM	1
20	CLASSROOM	1
21	CLASSROOM	1
22	CLASSROOM	1
23	CLASSROOM	1
24	CLASSROOM	1
25	CLASSROOM	1
26	CLASSROOM	1
27	CLASSROOM	1
28	CLASSROOM	1
29	CLASSROOM	1
30	CLASSROOM	1
31	CLASSROOM	1
32	CLASSROOM	1
33	CLASSROOM	1
34	CLASSROOM	1
35	CLASSROOM	1
36	CLASSROOM	1
37	CLASSROOM	1
38	CLASSROOM	1
39	CLASSROOM	1
40	CLASSROOM	1
41	CLASSROOM	1
42	CLASSROOM	1
43	CLASSROOM	1
44	CLASSROOM	1
45	CLASSROOM	1
46	CLASSROOM	1
47	CLASSROOM	1
48	CLASSROOM	1
49	CLASSROOM	1
50	CLASSROOM	1

**NOTES:**

1. ALL ACCESSIBLE TOILETS SHALL BE PROVIDED WITHIN EACH CLASSROOM AND ADMINISTRATIVE BUILDING.
2. ALL ACCESSIBLE TOILETS SHALL BE PROVIDED WITHIN EACH CLASSROOM AND ADMINISTRATIVE BUILDING.
3. ALL ACCESSIBLE TOILETS SHALL BE PROVIDED WITHIN EACH CLASSROOM AND ADMINISTRATIVE BUILDING.
4. ALL ACCESSIBLE TOILETS SHALL BE PROVIDED WITHIN EACH CLASSROOM AND ADMINISTRATIVE BUILDING.
5. ALL ACCESSIBLE TOILETS SHALL BE PROVIDED WITHIN EACH CLASSROOM AND ADMINISTRATIVE BUILDING.
6. ALL ACCESSIBLE TOILETS SHALL BE PROVIDED WITHIN EACH CLASSROOM AND ADMINISTRATIVE BUILDING.
7. ALL ACCESSIBLE TOILETS SHALL BE PROVIDED WITHIN EACH CLASSROOM AND ADMINISTRATIVE BUILDING.
8. ALL ACCESSIBLE TOILETS SHALL BE PROVIDED WITHIN EACH CLASSROOM AND ADMINISTRATIVE BUILDING.
9. ALL ACCESSIBLE TOILETS SHALL BE PROVIDED WITHIN EACH CLASSROOM AND ADMINISTRATIVE BUILDING.
10. ALL ACCESSIBLE TOILETS SHALL BE PROVIDED WITHIN EACH CLASSROOM AND ADMINISTRATIVE BUILDING.
11. ALL ACCESSIBLE TOILETS SHALL BE PROVIDED WITHIN EACH CLASSROOM AND ADMINISTRATIVE BUILDING.
12. ALL ACCESSIBLE TOILETS SHALL BE PROVIDED WITHIN EACH CLASSROOM AND ADMINISTRATIVE BUILDING.
13. ALL ACCESSIBLE TOILETS SHALL BE PROVIDED WITHIN EACH CLASSROOM AND ADMINISTRATIVE BUILDING.
14. ALL ACCESSIBLE TOILETS SHALL BE PROVIDED WITHIN EACH CLASSROOM AND ADMINISTRATIVE BUILDING.
15. ALL ACCESSIBLE TOILETS SHALL BE PROVIDED WITHIN EACH CLASSROOM AND ADMINISTRATIVE BUILDING.
16. ALL ACCESSIBLE TOILETS SHALL BE PROVIDED WITHIN EACH CLASSROOM AND ADMINISTRATIVE BUILDING.
17. ALL ACCESSIBLE TOILETS SHALL BE PROVIDED WITHIN EACH CLASSROOM AND ADMINISTRATIVE BUILDING.
18. ALL ACCESSIBLE TOILETS SHALL BE PROVIDED WITHIN EACH CLASSROOM AND ADMINISTRATIVE BUILDING.
19. ALL ACCESSIBLE TOILETS SHALL BE PROVIDED WITHIN EACH CLASSROOM AND ADMINISTRATIVE BUILDING.
20. ALL ACCESSIBLE TOILETS SHALL BE PROVIDED WITHIN EACH CLASSROOM AND ADMINISTRATIVE BUILDING.
21. ALL ACCESSIBLE TOILETS SHALL BE PROVIDED WITHIN EACH CLASSROOM AND ADMINISTRATIVE BUILDING.
22. ALL ACCESSIBLE TOILETS SHALL BE PROVIDED WITHIN EACH CLASSROOM AND ADMINISTRATIVE BUILDING.
23. ALL ACCESSIBLE TOILETS SHALL BE PROVIDED WITHIN EACH CLASSROOM AND ADMINISTRATIVE BUILDING.
24. ALL ACCESSIBLE TOILETS SHALL BE PROVIDED WITHIN EACH CLASSROOM AND ADMINISTRATIVE BUILDING.
25. ALL ACCESSIBLE TOILETS SHALL BE PROVIDED WITHIN EACH CLASSROOM AND ADMINISTRATIVE BUILDING.
26. ALL ACCESSIBLE TOILETS SHALL BE PROVIDED WITHIN EACH CLASSROOM AND ADMINISTRATIVE BUILDING.
27. ALL ACCESSIBLE TOILETS SHALL BE PROVIDED WITHIN EACH CLASSROOM AND ADMINISTRATIVE BUILDING.
28. ALL ACCESSIBLE TOILETS SHALL BE PROVIDED WITHIN EACH CLASSROOM AND ADMINISTRATIVE BUILDING.
29. ALL ACCESSIBLE TOILETS SHALL BE PROVIDED WITHIN EACH CLASSROOM AND ADMINISTRATIVE BUILDING.
30. ALL ACCESSIBLE TOILETS SHALL BE PROVIDED WITHIN EACH CLASSROOM AND ADMINISTRATIVE BUILDING.
31. ALL ACCESSIBLE TOILETS SHALL BE PROVIDED WITHIN EACH CLASSROOM AND ADMINISTRATIVE BUILDING.
32. ALL ACCESSIBLE TOILETS SHALL BE PROVIDED WITHIN EACH CLASSROOM AND ADMINISTRATIVE BUILDING.
33. ALL ACCESSIBLE TOILETS SHALL BE PROVIDED WITHIN EACH CLASSROOM AND ADMINISTRATIVE BUILDING.
34. ALL ACCESSIBLE TOILETS SHALL BE PROVIDED WITHIN EACH CLASSROOM AND ADMINISTRATIVE BUILDING.
35. ALL ACCESSIBLE TOILETS SHALL BE PROVIDED WITHIN EACH CLASSROOM AND ADMINISTRATIVE BUILDING.
36. ALL ACCESSIBLE TOILETS SHALL BE PROVIDED WITHIN EACH CLASSROOM AND ADMINISTRATIVE BUILDING.
37. ALL ACCESSIBLE TOILETS SHALL BE PROVIDED WITHIN EACH CLASSROOM AND ADMINISTRATIVE BUILDING.
38. ALL ACCESSIBLE TOILETS SHALL BE PROVIDED WITHIN EACH CLASSROOM AND ADMINISTRATIVE BUILDING.
39. ALL ACCESSIBLE TOILETS SHALL BE PROVIDED WITHIN EACH CLASSROOM AND ADMINISTRATIVE BUILDING.
40. ALL ACCESSIBLE TOILETS SHALL BE PROVIDED WITHIN EACH CLASSROOM AND ADMINISTRATIVE BUILDING.
41. ALL ACCESSIBLE TOILETS SHALL BE PROVIDED WITHIN EACH CLASSROOM AND ADMINISTRATIVE BUILDING.
42. ALL ACCESSIBLE TOILETS SHALL BE PROVIDED WITHIN EACH CLASSROOM AND ADMINISTRATIVE BUILDING.
43. ALL ACCESSIBLE TOILETS SHALL BE PROVIDED WITHIN EACH CLASSROOM AND ADMINISTRATIVE BUILDING.
44. ALL ACCESSIBLE TOILETS SHALL BE PROVIDED WITHIN EACH CLASSROOM AND ADMINISTRATIVE BUILDING.
45. ALL ACCESSIBLE TOILETS SHALL BE PROVIDED WITHIN EACH CLASSROOM AND ADMINISTRATIVE BUILDING.
46. ALL ACCESSIBLE TOILETS SHALL BE PROVIDED WITHIN EACH CLASSROOM AND ADMINISTRATIVE BUILDING.
47. ALL ACCESSIBLE TOILETS SHALL BE PROVIDED WITHIN EACH CLASSROOM AND ADMINISTRATIVE BUILDING.
48. ALL ACCESSIBLE TOILETS SHALL BE PROVIDED WITHIN EACH CLASSROOM AND ADMINISTRATIVE BUILDING.
49. ALL ACCESSIBLE TOILETS SHALL BE PROVIDED WITHIN EACH CLASSROOM AND ADMINISTRATIVE BUILDING.
50. ALL ACCESSIBLE TOILETS SHALL BE PROVIDED WITHIN EACH CLASSROOM AND ADMINISTRATIVE BUILDING.

NOTE: BID PACKAGE NOTES IN RED ISSUED BY BCF 2/17/2021

**Blair Church Flynn**  
CONSTRUCTION MANAGEMENT

**Clowis Unified School District**  
2021 PAVEMENT REHABILITATION  
VARIOUS SITES  
COOPER HILLS ELEMENTARY SCHOOL  
ACCESS COMPLIANCE PLAN

**CONST. DOCUMENTS**  
CH-2

E. PLYMOUTH AVENUE

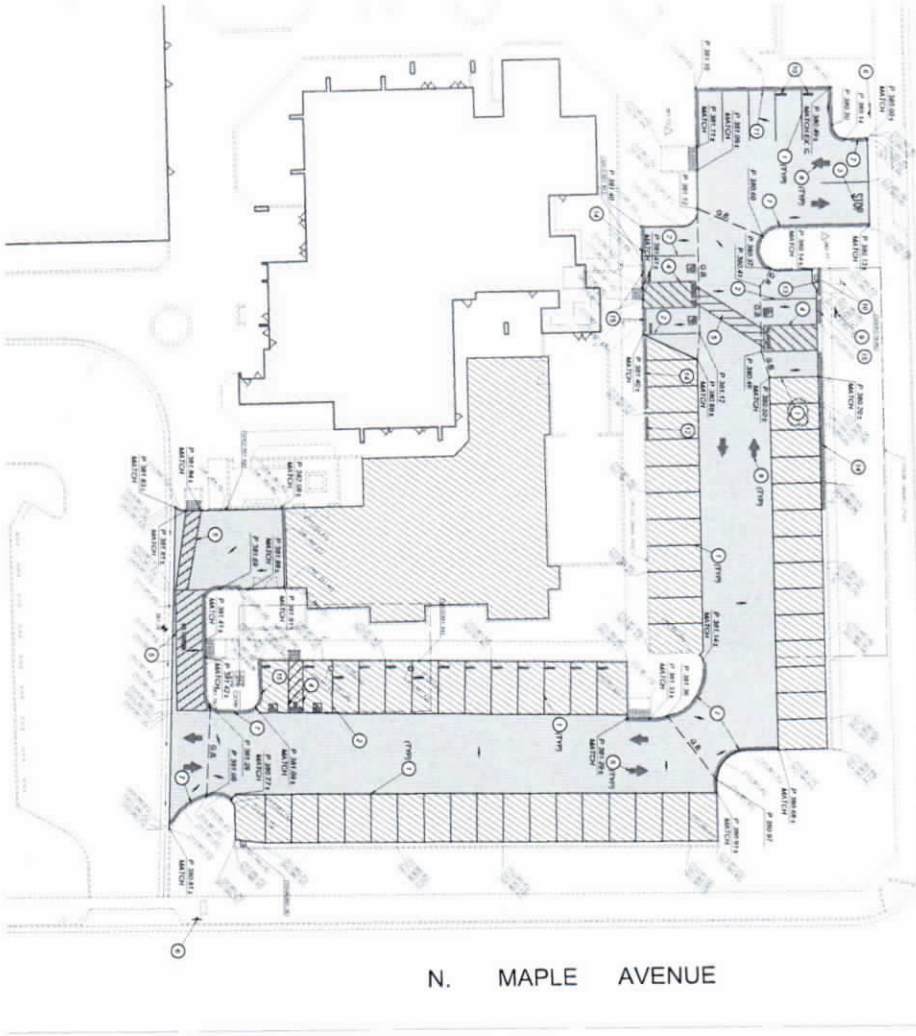

AREA A PARKING LOT

N. MAPLE AVENUE

GENERAL NOTES

1. THE CONTRACTOR SHALL BE RESPONSIBLE FOR OBTAINING ALL NECESSARY PERMITS AND APPROVALS FROM THE CITY OF CLAVIS AND THE CLAVIS SCHOOL DISTRICT.
2. THE CONTRACTOR SHALL BE RESPONSIBLE FOR OBTAINING ALL NECESSARY PERMITS AND APPROVALS FROM THE CITY OF CLAVIS AND THE CLAVIS SCHOOL DISTRICT.
3. THE CONTRACTOR SHALL BE RESPONSIBLE FOR OBTAINING ALL NECESSARY PERMITS AND APPROVALS FROM THE CITY OF CLAVIS AND THE CLAVIS SCHOOL DISTRICT.
4. THE CONTRACTOR SHALL BE RESPONSIBLE FOR OBTAINING ALL NECESSARY PERMITS AND APPROVALS FROM THE CITY OF CLAVIS AND THE CLAVIS SCHOOL DISTRICT.
5. THE CONTRACTOR SHALL BE RESPONSIBLE FOR OBTAINING ALL NECESSARY PERMITS AND APPROVALS FROM THE CITY OF CLAVIS AND THE CLAVIS SCHOOL DISTRICT.
6. THE CONTRACTOR SHALL BE RESPONSIBLE FOR OBTAINING ALL NECESSARY PERMITS AND APPROVALS FROM THE CITY OF CLAVIS AND THE CLAVIS SCHOOL DISTRICT.
7. THE CONTRACTOR SHALL BE RESPONSIBLE FOR OBTAINING ALL NECESSARY PERMITS AND APPROVALS FROM THE CITY OF CLAVIS AND THE CLAVIS SCHOOL DISTRICT.
8. THE CONTRACTOR SHALL BE RESPONSIBLE FOR OBTAINING ALL NECESSARY PERMITS AND APPROVALS FROM THE CITY OF CLAVIS AND THE CLAVIS SCHOOL DISTRICT.
9. THE CONTRACTOR SHALL BE RESPONSIBLE FOR OBTAINING ALL NECESSARY PERMITS AND APPROVALS FROM THE CITY OF CLAVIS AND THE CLAVIS SCHOOL DISTRICT.
10. THE CONTRACTOR SHALL BE RESPONSIBLE FOR OBTAINING ALL NECESSARY PERMITS AND APPROVALS FROM THE CITY OF CLAVIS AND THE CLAVIS SCHOOL DISTRICT.
11. THE CONTRACTOR SHALL BE RESPONSIBLE FOR OBTAINING ALL NECESSARY PERMITS AND APPROVALS FROM THE CITY OF CLAVIS AND THE CLAVIS SCHOOL DISTRICT.
12. THE CONTRACTOR SHALL BE RESPONSIBLE FOR OBTAINING ALL NECESSARY PERMITS AND APPROVALS FROM THE CITY OF CLAVIS AND THE CLAVIS SCHOOL DISTRICT.
13. THE CONTRACTOR SHALL BE RESPONSIBLE FOR OBTAINING ALL NECESSARY PERMITS AND APPROVALS FROM THE CITY OF CLAVIS AND THE CLAVIS SCHOOL DISTRICT.
14. THE CONTRACTOR SHALL BE RESPONSIBLE FOR OBTAINING ALL NECESSARY PERMITS AND APPROVALS FROM THE CITY OF CLAVIS AND THE CLAVIS SCHOOL DISTRICT.
15. THE CONTRACTOR SHALL BE RESPONSIBLE FOR OBTAINING ALL NECESSARY PERMITS AND APPROVALS FROM THE CITY OF CLAVIS AND THE CLAVIS SCHOOL DISTRICT.
16. THE CONTRACTOR SHALL BE RESPONSIBLE FOR OBTAINING ALL NECESSARY PERMITS AND APPROVALS FROM THE CITY OF CLAVIS AND THE CLAVIS SCHOOL DISTRICT.
17. THE CONTRACTOR SHALL BE RESPONSIBLE FOR OBTAINING ALL NECESSARY PERMITS AND APPROVALS FROM THE CITY OF CLAVIS AND THE CLAVIS SCHOOL DISTRICT.
18. THE CONTRACTOR SHALL BE RESPONSIBLE FOR OBTAINING ALL NECESSARY PERMITS AND APPROVALS FROM THE CITY OF CLAVIS AND THE CLAVIS SCHOOL DISTRICT.
19. THE CONTRACTOR SHALL BE RESPONSIBLE FOR OBTAINING ALL NECESSARY PERMITS AND APPROVALS FROM THE CITY OF CLAVIS AND THE CLAVIS SCHOOL DISTRICT.
20. THE CONTRACTOR SHALL BE RESPONSIBLE FOR OBTAINING ALL NECESSARY PERMITS AND APPROVALS FROM THE CITY OF CLAVIS AND THE CLAVIS SCHOOL DISTRICT.
21. THE CONTRACTOR SHALL BE RESPONSIBLE FOR OBTAINING ALL NECESSARY PERMITS AND APPROVALS FROM THE CITY OF CLAVIS AND THE CLAVIS SCHOOL DISTRICT.
22. THE CONTRACTOR SHALL BE RESPONSIBLE FOR OBTAINING ALL NECESSARY PERMITS AND APPROVALS FROM THE CITY OF CLAVIS AND THE CLAVIS SCHOOL DISTRICT.

CONSTRUCTION LEGEND

- 1. CONCRETE
- 2. PAVERSTONE
- 3. TOP OF CURB
- 4. FINISHED GRADE
- 5. CHANGING TO NEW GRADE
- 6. EXISTING GRADE
- 7. EXISTING GRADE
- 8. EXISTING GRADE
- 9. EXISTING GRADE
- 10. EXISTING GRADE
- 11. EXISTING GRADE
- 12. EXISTING GRADE
- 13. EXISTING GRADE
- 14. EXISTING GRADE
- 15. EXISTING GRADE
- 16. EXISTING GRADE
- 17. EXISTING GRADE
- 18. EXISTING GRADE
- 19. EXISTING GRADE
- 20. EXISTING GRADE
- 21. EXISTING GRADE
- 22. EXISTING GRADE

Blair Church of Christ  
COPPER HILLS ELEMENTARY SCHOOL  
PARTIAL SITE & GRADING PLAN

CLAVIS UNIFIED SCHOOL DISTRICT  
2021 PAVEMENT REHABILITATION  
VARIOUS SITES





CH-3.1

WORK IN THIS AREA IS  
NOT IN CONTRACT

N. MAPLE AVENUE

FOR BIDDING USE ONLY  
APP # 00118065

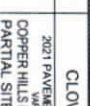
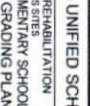
NOTE: BID PACKAGE NOTES IN  
RED ISSUED BY BCF 3/6/2021

					
Blair Church of Christ	City of Clowis CONSTRUCTION SERVICES	CONSULTING ENGINEER	NEP # 4001 S&M	2021 PAVEMENT REHABILITATION WORKSITES BY SCHOOL PARTIAL SITE & GRADING PLAN	CLOWIS UNIFIED SCHOOL DISTRICT CONSTR. DOCUMENTS CH-4





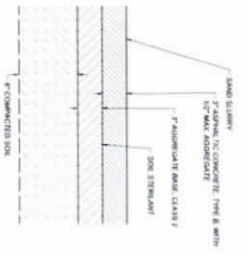

**A** ASPHALT CONCRETE PAVEMENT SECTION  
CHX-1 NOT TO SCALE

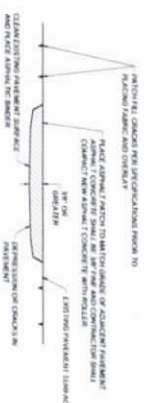

**B** CRACK PATCHING DETAIL  
CHX-1 NOT TO SCALE

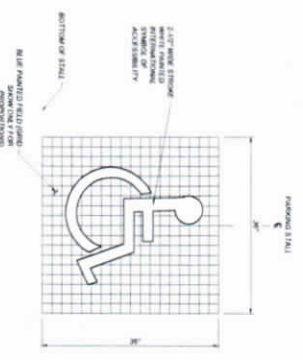

**C** ACCESSIBLE SYMBOL  
CHX-1 NOT TO SCALE

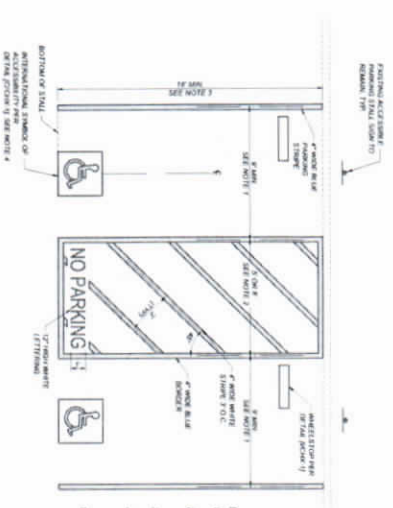

**D** TYPICAL ACCESSIBLE PARKING STALL DETAIL  
CHX-1 NOT TO SCALE

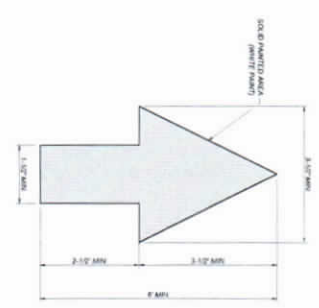

**E** DIRECTIONAL ARROW  
CHX-1 NOT TO SCALE

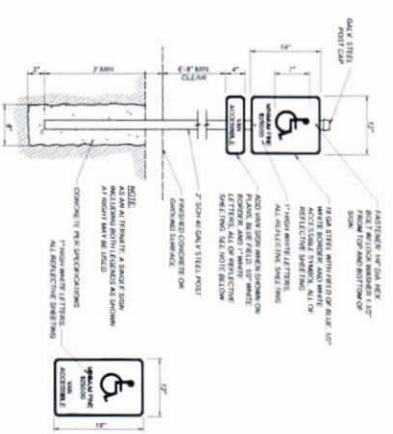

**F** ACCESSIBLE PARKING STALL SIGN  
CHX-1 NOT TO SCALE

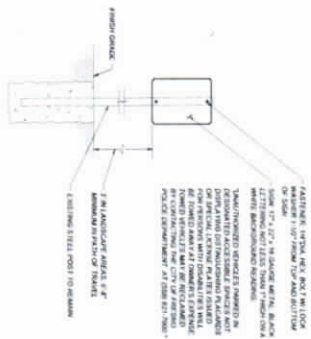

**G** ENTRY TOW AWAY SIGN  
CHX-1 NOT TO SCALE

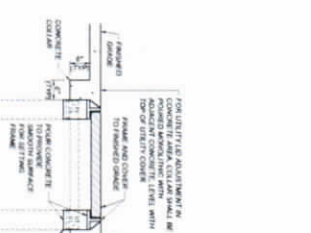

**H** ADJUST UTILITY LID  
CHX-1 NOT TO SCALE

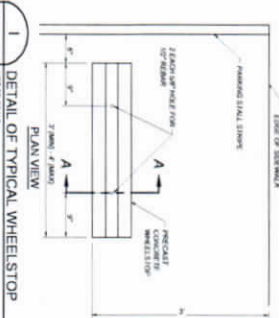

**I** DETAIL OF TYPICAL WHEELSTOP  
CHX-1 NOT TO SCALE

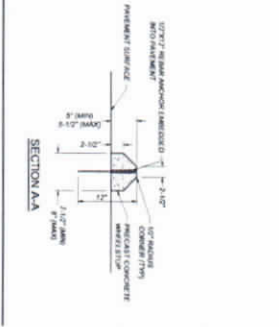

**J** SECTION A-A  
CHX-1 NOT TO SCALE

	CONTRACTOR Blair Church Flynn CONSULTING ENGINEERS	CONSULTING ENGINEER Blair Church Flynn CONSULTING ENGINEERS	PREPARED BY 2021 PAVEMENT REHABILITATION COPPER HILLS ELEMENTARY SCHOOL SITE DETAILS	PROJECT NO. 2021 PAVEMENT REHABILITATION COPPER HILLS ELEMENTARY SCHOOL SITE DETAILS	DRAWING NO. CHX-1
	CLOVIS UNIFIED SCHOOL DISTRICT CONST. DOCUMENTS CHX-1				



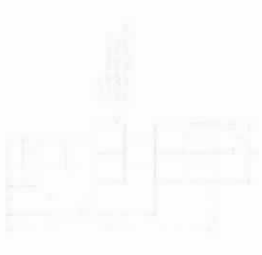
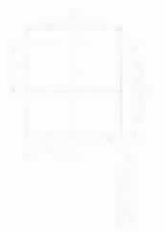
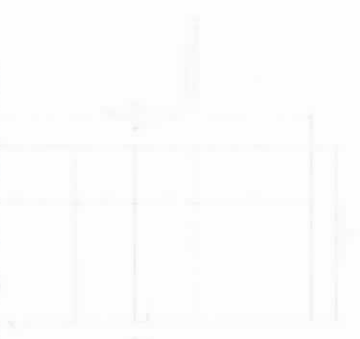
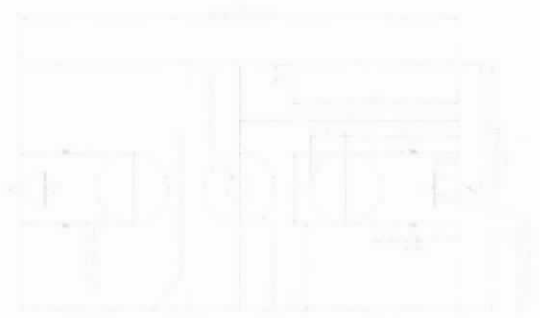

FOR DATA USE ONLY  
APP # 02-18055

DETAILS "A" THROUGH "E" ON THIS SHEET ARE NOT IN THE CONTRACT



GENERAL NOTES FOR APPLICANT'S ATTENTION

NOTE: BID PACKAGE NOTES IN RED ISSUED BY BCF 3/5/2021

				<b>CLOVIS UNIFIED SCHOOL DISTRICT</b>	<b>CONST. DOCUMENTS</b>
<b>Blair Church Hymn</b>				<b>2021 PAVEMENT REHABILITATION VARIOUS SITES</b>	<b>CHX-2</b>
<b>CONSULTING ENGINEER</b>				<b>COPPER HILLS ELEMENTARY SCHOOL PLAYCOURT DETAILS</b>	

# CLOVIS UNIFIED SCHOOL DISTRICT

EIMEAR O'FARRELL, ED. D., DISTRICT SUPERINTENDENT  
**PLANS FOR THE CONSTRUCTION**  
**OF**  
**2021 PARKING LOT**  
**REHABILITATION IMPROVEMENTS**  
**AT**  
**DISTRICT OFFICE**

FOR YOUR USE ONLY  
 APP # 02-178051



**LOCATION MAP**  
 NOT TO SCALE

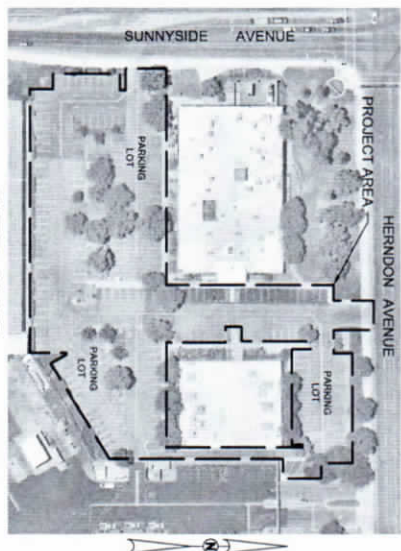

**SITE MAP**  
 NOT TO SCALE

ADDRESS  
 1401 HERNDON AVENUE  
 CLOVIS, CA 93611

**PROJECT CONTACTS**

OWNER: CLOVIS UNIFIED SCHOOL DISTRICT  
 CLAUDIA GARDNER  
 CLAUDIA.GARDNER@CUSD.EDU  
 PHONE: 558.329.4000

CON ENGINEER: RALPH CALDWELL & ASSOCIATES  
 4110 CALDWELL AVENUE  
 CLOVIS, CA 93611  
 PHONE: 558.329.4000

**SCOPE OF WORK**

1. CONCEPT AND FINAL CONSTRUCTION PLAN FOR PARKING LOT
2. PRELIMINARY PERMITS
3. PRELIMINARY BIDDING
4. CONSTRUCTION ADMINISTRATION

**APPLICABLE CODES:**

1. FLOOD HAZARD ZONE INFORMATION
2. CALIFORNIA CIVIL CODE
3. CALIFORNIA CONSTRUCTION CODE
4. CALIFORNIA FIRE CODE

**FLOOD HAZARD ZONE INFORMATION:**

1. FLOOD ZONE INFORMATION
2. FLOOD HAZARD ZONE INFORMATION
3. FLOOD HAZARD ZONE INFORMATION
4. FLOOD HAZARD ZONE INFORMATION

**GENERAL NOTES**

1. ALL WORK SHALL BE DONE IN ACCORDANCE WITH THE CITY OF CLOVIS SPECIFICATIONS AND THE CITY OF CLOVIS SPECIFICATIONS AND THE CITY OF CLOVIS SPECIFICATIONS.
2. THE CONTRACTOR SHALL COMPLY WITH ALL CITY SPECIFICATIONS AND THE CITY OF CLOVIS SPECIFICATIONS AND THE CITY OF CLOVIS SPECIFICATIONS.
3. THE CONTRACTOR SHALL COMPLY WITH ALL CITY SPECIFICATIONS AND THE CITY OF CLOVIS SPECIFICATIONS AND THE CITY OF CLOVIS SPECIFICATIONS.
4. THE CONTRACTOR SHALL COMPLY WITH ALL CITY SPECIFICATIONS AND THE CITY OF CLOVIS SPECIFICATIONS AND THE CITY OF CLOVIS SPECIFICATIONS.
5. THE CONTRACTOR SHALL COMPLY WITH ALL CITY SPECIFICATIONS AND THE CITY OF CLOVIS SPECIFICATIONS AND THE CITY OF CLOVIS SPECIFICATIONS.
6. THE CONTRACTOR SHALL COMPLY WITH ALL CITY SPECIFICATIONS AND THE CITY OF CLOVIS SPECIFICATIONS AND THE CITY OF CLOVIS SPECIFICATIONS.
7. THE CONTRACTOR SHALL COMPLY WITH ALL CITY SPECIFICATIONS AND THE CITY OF CLOVIS SPECIFICATIONS AND THE CITY OF CLOVIS SPECIFICATIONS.
8. THE CONTRACTOR SHALL COMPLY WITH ALL CITY SPECIFICATIONS AND THE CITY OF CLOVIS SPECIFICATIONS AND THE CITY OF CLOVIS SPECIFICATIONS.
9. THE CONTRACTOR SHALL COMPLY WITH ALL CITY SPECIFICATIONS AND THE CITY OF CLOVIS SPECIFICATIONS AND THE CITY OF CLOVIS SPECIFICATIONS.
10. THE CONTRACTOR SHALL COMPLY WITH ALL CITY SPECIFICATIONS AND THE CITY OF CLOVIS SPECIFICATIONS AND THE CITY OF CLOVIS SPECIFICATIONS.



Know what's below.  
 Call before you dig.

CLOVIS UNIFIED SCHOOL DISTRICT  
 VANDERBILT DISTRICT OFFICE  
 COVER SHEET

CONST. DOCUMENTS  
 DO-1

**TABLE OF CONTENTS**

SHEET NUMBER	SHEET TITLE
DO-1	COVER SHEET
DO-2	2021 PARKING LOT REHABILITATION
DO-3	DETAILS

TOTAL SHEET COUNT: 3



WARNING: THE USER OF THIS PLAN SHALL BE RESPONSIBLE FOR OBTAINING ALL NECESSARY PERMITS AND APPROVALS FROM THE APPROPRIATE AGENCIES. THE USER SHALL BE RESPONSIBLE FOR OBTAINING ALL NECESSARY PERMITS AND APPROVALS FROM THE APPROPRIATE AGENCIES. THE USER SHALL BE RESPONSIBLE FOR OBTAINING ALL NECESSARY PERMITS AND APPROVALS FROM THE APPROPRIATE AGENCIES.

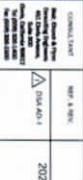

CLOVIS UNIFIED SCHOOL DISTRICT  
 VANDERBILT DISTRICT OFFICE  
 COVER SHEET

CONST. DOCUMENTS  
 DO-1



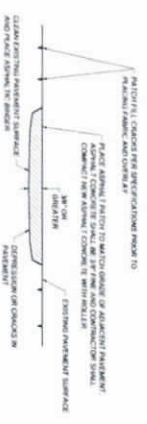

**A** CRACK PATCHING DETAIL  
DOX-1 NOT TO SCALE

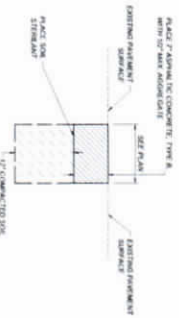

**B** ASPHALT CONCRETE PLUG  
DOX-1 NOT TO SCALE

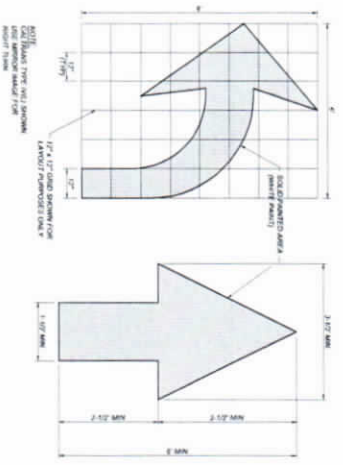

**C** DIRECTIONAL ARROWS  
DOX-1 NOT TO SCALE

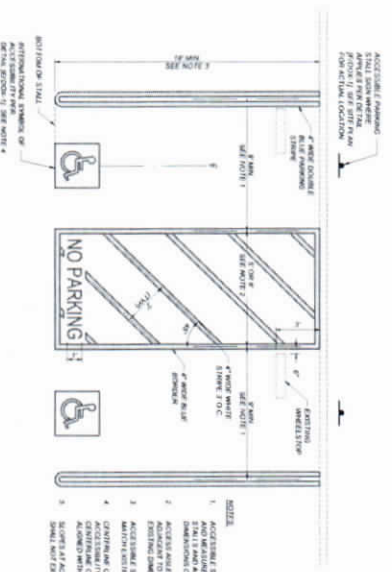

**D** ACCESSIBLE PARKING STALL DETAIL  
DOX-1 NOT TO SCALE

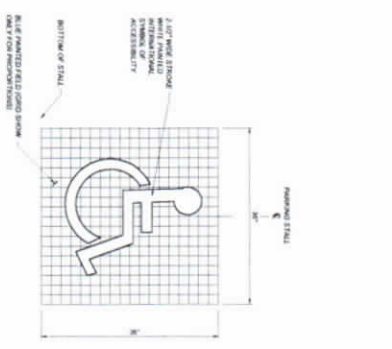

**E** ACCESSIBLE SYMBOL  
DOX-1 NOT TO SCALE

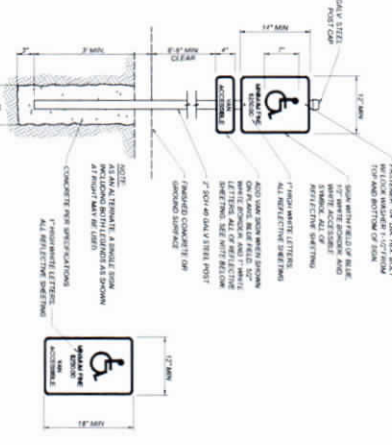

**F** ACCESSIBLE PARKING STALL SIGN  
DOX-1 NOT TO SCALE

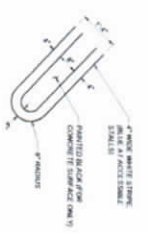

**G** DOUBLE PAVING STRIPE  
DOX-1 NOT TO SCALE

CONTRACTOR: 2021 PAVEMENT REHABILITATION VARIOUS SITES DISTRICT OFFICE DETAILS	2021 PAVEMENT REHABILITATION VARIOUS SITES DISTRICT OFFICE DETAILS	2021 PAVEMENT REHABILITATION VARIOUS SITES DISTRICT OFFICE DETAILS	2021 PAVEMENT REHABILITATION VARIOUS SITES DISTRICT OFFICE DETAILS

# CLOVIS UNIFIED SCHOOL DISTRICT

EMEAR O'FARRELL, ED. D., DISTRICT SUPERINTENDENT

PLANS FOR THE CONSTRUCTION

OF

2021 PARKING LOT AND PLAYCOURT  
REHABILITATION IMPROVEMENTS

AT

GARFIELD ELEMENTARY SCHOOL

1/28/2021 10:00 AM  
APP # 02-118049



## LOCATION MAP

NOT TO SCALE

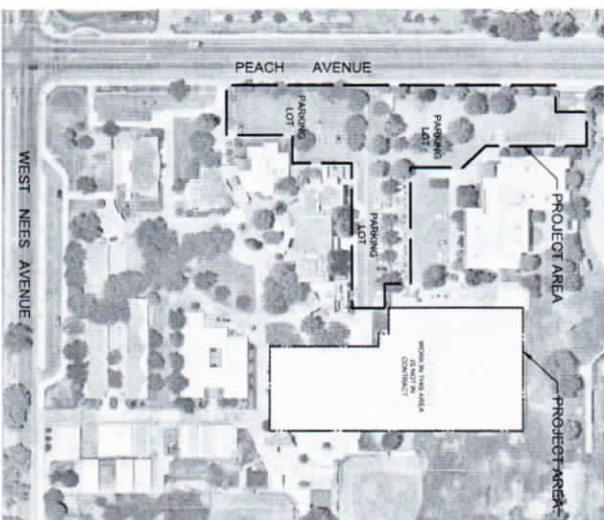

## SITE MAP

NOT TO SCALE

ADDRESS  
17171 W. NEES AVE  
CLOVIS, CA 93618

### PROJECT CONTACTS:

OWNER: CLOVIS UNIFIED SCHOOL DISTRICT  
 PROJECT MANAGER: EMMER O'FARRELL  
 DESIGNER: BLAIR CHURCH & FLYNN  
 ENGINEER: CLOVIS CITY ENGINEER  
 CONTRACT NO: 2021-001

### SCOPE OF WORK:

- REPAIR AND REPLACE DAMAGED OR NON-COMPLIANT ASPHALT
- REPAIR AND REPLACE DAMAGED OR NON-COMPLIANT PLAYCOURT
- CONTRACT FOR AND INSTALL CONCRETE PAVEMENT AT PARKING LOT
- REPAIR PLAYCOURT AND PLAYCOURT

### APPLICABLE CODES:

- 2015 CALIFORNIA BUILDING CODE, TITLE 24, PART 7, CODE
- 2015 CALIFORNIA FIRE CODE, TITLE 24, PART 7, CODE
- 2015 CALIFORNIA PLUMBING CODE, TITLE 24, PART 7, CODE
- 2015 CALIFORNIA ELECTRICAL CODE, TITLE 24, PART 7, CODE

### FLOOD HAZARD ZONE INFORMATION:

- FLOOD ZONE DESIGNATION: ZONE 2, AREA 4 OF 4, 2N  
 FLOOD ZONE: 2N  
 FLOOD ZONE: 2N  
 FLOOD ZONE: 2N



Know what's below.  
Call before you dig.

### CLOVIS UNIFIED SCHOOL DISTRICT

2021 PARKING LOT AND PLAYCOURT REHABILITATION VARIATION SHEET COVER SHEET

CONST. DOCUMENTS

GA-1

### TABLE OF CONTENTS

SHEET NUMBER	SHEET TITLE
GA-1	COVER SHEET
GA-2	ACCESS COMPLIANCE PLAN
GA-3	BID AND BIDDING PLAN
GA-4	DETAILS
GA-5	DETAILS
TOTAL SHEET COUNT: 5	



NOTE: BID PACKAGE NOTES IN RED ISSUED BY BCF 3/6/2021

Blair Church & Flynn  
ENGINEERING AND DESIGN



2021 PARKING LOT AND PLAYCOURT REHABILITATION VARIATION SHEET COVER SHEET

CLOVIS UNIFIED SCHOOL DISTRICT

CONST. DOCUMENTS

GA-1

PEACH AVENUE

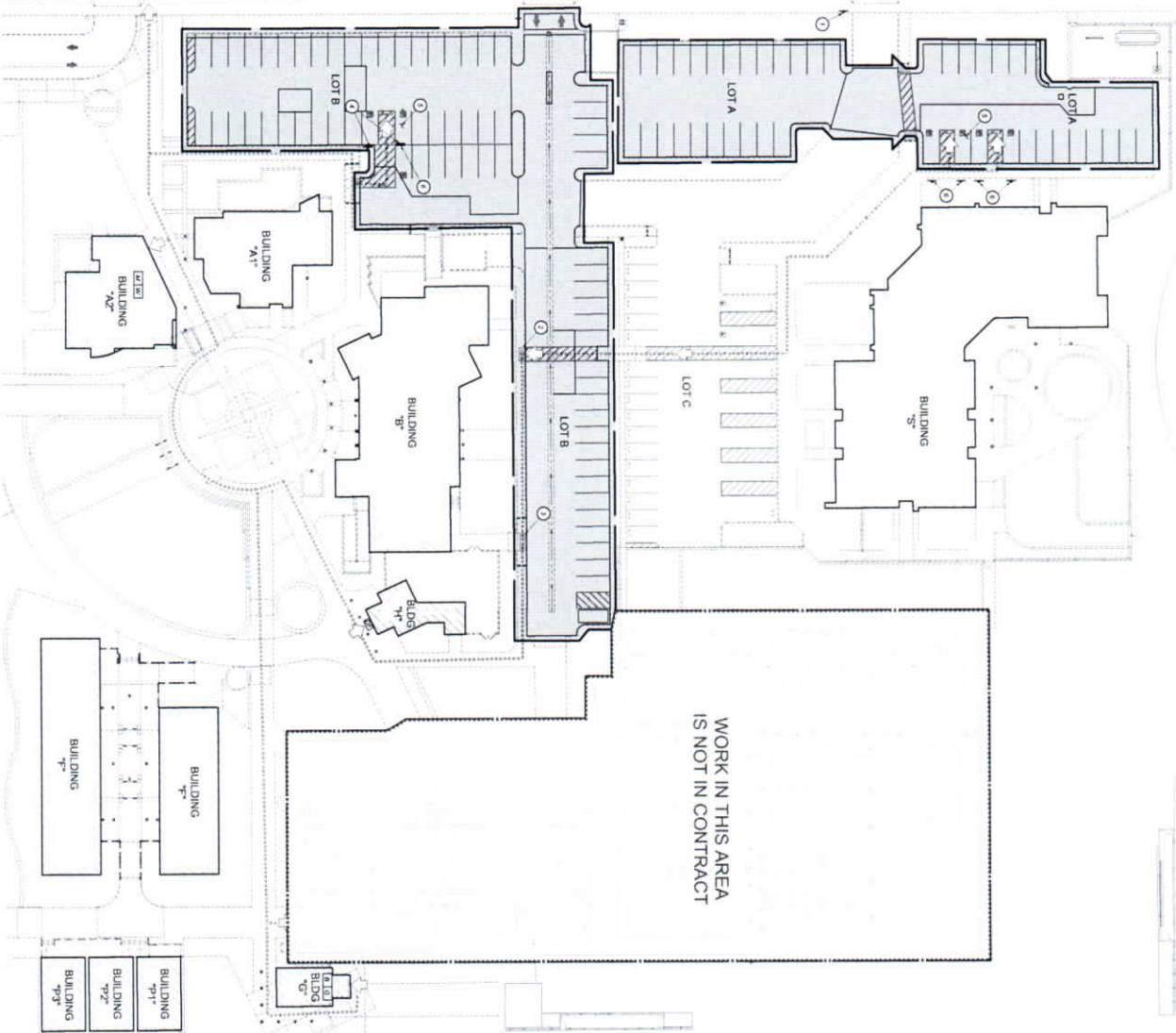

WORK IN THIS AREA IS NOT IN CONTRACT

NOTE: BID PACKAGE NOTES IN RED ISSUED BY BCR-3/9/2021

**Blair Church Flynn**

CONSULTING ENGINEERS

DATE: 2/2021

PROJECT NO: 2021 PAVEMENT REHABILITATION

CLOWIS UNIFIED SCHOOL DISTRICT

GARFIELD ELEMENTARY SCHOOL

ACCESS COMPLIANCE PLAN

CONST. DOCUMENTS

GA-2

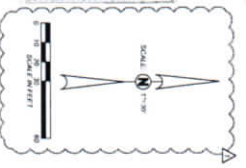

**SITE LEGEND:**

- (1) LIMITS OF WORK
- (2) EXISTING ACCESSIBLE FLOOR OF TRAVEL PER ADA AND 9012785
- (3) ACCESSIBLE PATH RESTRICTION
- (4) ACCESSIBLE PATHWAY RESTRICTION
- (5) ACCESSIBLE PATHWAY RESTRICTION PER ADA AND 9012785
- (6) ACCESSIBLE BARRIER RESTRICTION PER ADA AND 9012785
- (7) ACCESSIBLE SIGN RESTRICTION PER ADA AND 9012785
- (8) ACCESSIBLE SIGN RESTRICTION PER ADA AND 9012785
- (9) ACCESSIBLE SIGN RESTRICTION PER ADA AND 9012785
- (10) ACCESSIBLE SIGN RESTRICTION PER ADA AND 9012785
- (11) ACCESSIBLE SIGN RESTRICTION PER ADA AND 9012785
- (12) ACCESSIBLE SIGN RESTRICTION PER ADA AND 9012785
- (13) ACCESSIBLE SIGN RESTRICTION PER ADA AND 9012785
- (14) ACCESSIBLE SIGN RESTRICTION PER ADA AND 9012785
- (15) ACCESSIBLE SIGN RESTRICTION PER ADA AND 9012785
- (16) ACCESSIBLE SIGN RESTRICTION PER ADA AND 9012785
- (17) ACCESSIBLE SIGN RESTRICTION PER ADA AND 9012785
- (18) ACCESSIBLE SIGN RESTRICTION PER ADA AND 9012785
- (19) ACCESSIBLE SIGN RESTRICTION PER ADA AND 9012785
- (20) ACCESSIBLE SIGN RESTRICTION PER ADA AND 9012785
- (21) ACCESSIBLE SIGN RESTRICTION PER ADA AND 9012785
- (22) ACCESSIBLE SIGN RESTRICTION PER ADA AND 9012785
- (23) ACCESSIBLE SIGN RESTRICTION PER ADA AND 9012785
- (24) ACCESSIBLE SIGN RESTRICTION PER ADA AND 9012785
- (25) ACCESSIBLE SIGN RESTRICTION PER ADA AND 9012785
- (26) ACCESSIBLE SIGN RESTRICTION PER ADA AND 9012785
- (27) ACCESSIBLE SIGN RESTRICTION PER ADA AND 9012785
- (28) ACCESSIBLE SIGN RESTRICTION PER ADA AND 9012785
- (29) ACCESSIBLE SIGN RESTRICTION PER ADA AND 9012785
- (30) ACCESSIBLE SIGN RESTRICTION PER ADA AND 9012785
- (31) ACCESSIBLE SIGN RESTRICTION PER ADA AND 9012785
- (32) ACCESSIBLE SIGN RESTRICTION PER ADA AND 9012785
- (33) ACCESSIBLE SIGN RESTRICTION PER ADA AND 9012785
- (34) ACCESSIBLE SIGN RESTRICTION PER ADA AND 9012785
- (35) ACCESSIBLE SIGN RESTRICTION PER ADA AND 9012785
- (36) ACCESSIBLE SIGN RESTRICTION PER ADA AND 9012785
- (37) ACCESSIBLE SIGN RESTRICTION PER ADA AND 9012785
- (38) ACCESSIBLE SIGN RESTRICTION PER ADA AND 9012785
- (39) ACCESSIBLE SIGN RESTRICTION PER ADA AND 9012785
- (40) ACCESSIBLE SIGN RESTRICTION PER ADA AND 9012785
- (41) ACCESSIBLE SIGN RESTRICTION PER ADA AND 9012785
- (42) ACCESSIBLE SIGN RESTRICTION PER ADA AND 9012785
- (43) ACCESSIBLE SIGN RESTRICTION PER ADA AND 9012785
- (44) ACCESSIBLE SIGN RESTRICTION PER ADA AND 9012785
- (45) ACCESSIBLE SIGN RESTRICTION PER ADA AND 9012785
- (46) ACCESSIBLE SIGN RESTRICTION PER ADA AND 9012785
- (47) ACCESSIBLE SIGN RESTRICTION PER ADA AND 9012785
- (48) ACCESSIBLE SIGN RESTRICTION PER ADA AND 9012785
- (49) ACCESSIBLE SIGN RESTRICTION PER ADA AND 9012785
- (50) ACCESSIBLE SIGN RESTRICTION PER ADA AND 9012785

**PARKING CALCULATIONS:**

LOT #	AREA	PERCENTAGE COVERED	PERCENTAGE AVAILABLE
1	1,500	75%	1,125
2	1,500	75%	1,125
3	1,500	75%	1,125
4	1,500	75%	1,125
5	1,500	75%	1,125
6	1,500	75%	1,125
7	1,500	75%	1,125
8	1,500	75%	1,125
9	1,500	75%	1,125
10	1,500	75%	1,125
11	1,500	75%	1,125
12	1,500	75%	1,125
13	1,500	75%	1,125
14	1,500	75%	1,125
15	1,500	75%	1,125
16	1,500	75%	1,125
17	1,500	75%	1,125
18	1,500	75%	1,125
19	1,500	75%	1,125
20	1,500	75%	1,125
21	1,500	75%	1,125
22	1,500	75%	1,125
23	1,500	75%	1,125
24	1,500	75%	1,125
25	1,500	75%	1,125
26	1,500	75%	1,125
27	1,500	75%	1,125
28	1,500	75%	1,125
29	1,500	75%	1,125
30	1,500	75%	1,125
31	1,500	75%	1,125
32	1,500	75%	1,125
33	1,500	75%	1,125
34	1,500	75%	1,125
35	1,500	75%	1,125
36	1,500	75%	1,125
37	1,500	75%	1,125
38	1,500	75%	1,125
39	1,500	75%	1,125
40	1,500	75%	1,125
41	1,500	75%	1,125
42	1,500	75%	1,125
43	1,500	75%	1,125
44	1,500	75%	1,125
45	1,500	75%	1,125
46	1,500	75%	1,125
47	1,500	75%	1,125
48	1,500	75%	1,125
49	1,500	75%	1,125
50	1,500	75%	1,125

**NOTES:**

1. THE RAILROAD TRAVEL IS NOT IDENTIFIED IN THESE CONSTRUCTION DOCUMENTS COMPLIANT WITH THE CURRENT APPLICABLE DOCUMENTS. THE CONTRACTOR SHALL BE RESPONSIBLE FOR OBTAINING NECESSARY PERMITS AND APPROVALS FROM THE LOCAL AGENCIES AND THE FEDERAL GOVERNMENT FOR THE RAILROAD TRAVEL. THE CONTRACTOR SHALL BE RESPONSIBLE FOR OBTAINING NECESSARY PERMITS AND APPROVALS FROM THE LOCAL AGENCIES AND THE FEDERAL GOVERNMENT FOR THE RAILROAD TRAVEL. THE CONTRACTOR SHALL BE RESPONSIBLE FOR OBTAINING NECESSARY PERMITS AND APPROVALS FROM THE LOCAL AGENCIES AND THE FEDERAL GOVERNMENT FOR THE RAILROAD TRAVEL. THE CONTRACTOR SHALL BE RESPONSIBLE FOR OBTAINING NECESSARY PERMITS AND APPROVALS FROM THE LOCAL AGENCIES AND THE FEDERAL GOVERNMENT FOR THE RAILROAD TRAVEL.

**BUILDING LEGEND:**

BUILDING ID	DESCRIPTION	SIZE (sq ft)	TYPE
A1	SCHOOL	20,000	NEW
A2	ADDITIONAL	10,000	NEW
B	WALKWAY	500	EXIST
C	WALKWAY	500	EXIST
D	WALKWAY	500	EXIST
E	WALKWAY	500	EXIST
F	WALKWAY	500	EXIST
G	WALKWAY	500	EXIST
H	WALKWAY	500	EXIST
I	WALKWAY	500	EXIST
J	WALKWAY	500	EXIST
K	WALKWAY	500	EXIST
L	WALKWAY	500	EXIST
M	WALKWAY	500	EXIST
N	WALKWAY	500	EXIST
O	WALKWAY	500	EXIST
P	WALKWAY	500	EXIST
Q	WALKWAY	500	EXIST
R	WALKWAY	500	EXIST
S	WALKWAY	500	EXIST
T	WALKWAY	500	EXIST
U	WALKWAY	500	EXIST
V	WALKWAY	500	EXIST
W	WALKWAY	500	EXIST
X	WALKWAY	500	EXIST
Y	WALKWAY	500	EXIST
Z	WALKWAY	500	EXIST

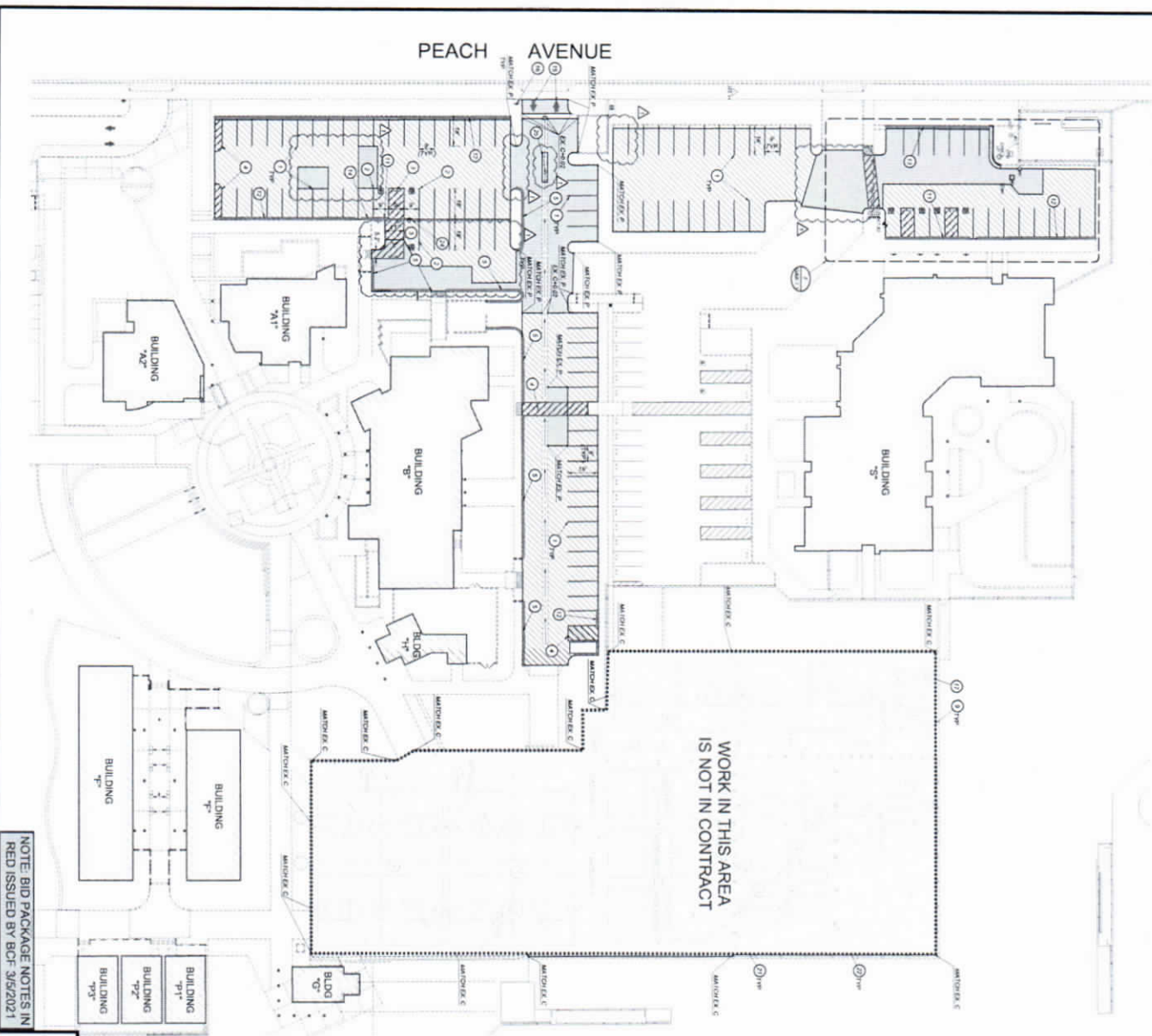

WORK IN THIS AREA IS NOT IN CONTRACT

NOTE: BID PACKAGE NOTES IN RED ISSUED BY BCF 3/9/2021

Blair Church Gymnasium  
CONSTRUCTION PLAN SHEET



CONTRACT NO. 2021-001  
DATE: 03/09/21  
PROJECT: 2021 PAVEMENT REHABILITATION GARFIELD ELEMENTARY SCHOOL SITE & GRADING PLAN

CLOVIS UNIFIED SCHOOL DISTRICT  
CONSTRUCTION DOCUMENTS  
GA-3.1

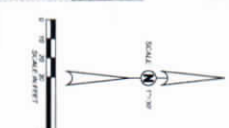

- 1. GENERAL NOTES AND ADDENDUMS OF THIS BIDDING AND PROVISIONS OF THE CONTRACT SHALL BE COMBINED BY THE BIDDERS AND THE SPECIFICATIONS AND ANY CONFLICTS SHALL BE RESOLVED BY THE BIDDERS.
- 2. CONTRACTOR SHALL VERIFY ALL SIZES AND SIZES FROM THE CONTRACT DOCUMENTS AND THE SIZES FROM THE CONTRACT DOCUMENTS SHALL BE THE SAME AS THE SIZES FROM THE CONTRACT DOCUMENTS.
- 3. CONTRACTOR SHALL VERIFY ALL SIZES AND SIZES FROM THE CONTRACT DOCUMENTS AND THE SIZES FROM THE CONTRACT DOCUMENTS SHALL BE THE SAME AS THE SIZES FROM THE CONTRACT DOCUMENTS.
- 4. CONTRACTOR SHALL VERIFY ALL SIZES AND SIZES FROM THE CONTRACT DOCUMENTS AND THE SIZES FROM THE CONTRACT DOCUMENTS SHALL BE THE SAME AS THE SIZES FROM THE CONTRACT DOCUMENTS.
- 5. CONTRACTOR SHALL VERIFY ALL SIZES AND SIZES FROM THE CONTRACT DOCUMENTS AND THE SIZES FROM THE CONTRACT DOCUMENTS SHALL BE THE SAME AS THE SIZES FROM THE CONTRACT DOCUMENTS.
- 6. CONTRACTOR SHALL VERIFY ALL SIZES AND SIZES FROM THE CONTRACT DOCUMENTS AND THE SIZES FROM THE CONTRACT DOCUMENTS SHALL BE THE SAME AS THE SIZES FROM THE CONTRACT DOCUMENTS.
- 7. CONTRACTOR SHALL VERIFY ALL SIZES AND SIZES FROM THE CONTRACT DOCUMENTS AND THE SIZES FROM THE CONTRACT DOCUMENTS SHALL BE THE SAME AS THE SIZES FROM THE CONTRACT DOCUMENTS.
- 8. CONTRACTOR SHALL VERIFY ALL SIZES AND SIZES FROM THE CONTRACT DOCUMENTS AND THE SIZES FROM THE CONTRACT DOCUMENTS SHALL BE THE SAME AS THE SIZES FROM THE CONTRACT DOCUMENTS.
- 9. CONTRACTOR SHALL VERIFY ALL SIZES AND SIZES FROM THE CONTRACT DOCUMENTS AND THE SIZES FROM THE CONTRACT DOCUMENTS SHALL BE THE SAME AS THE SIZES FROM THE CONTRACT DOCUMENTS.
- 10. CONTRACTOR SHALL VERIFY ALL SIZES AND SIZES FROM THE CONTRACT DOCUMENTS AND THE SIZES FROM THE CONTRACT DOCUMENTS SHALL BE THE SAME AS THE SIZES FROM THE CONTRACT DOCUMENTS.
- 11. CONTRACTOR SHALL VERIFY ALL SIZES AND SIZES FROM THE CONTRACT DOCUMENTS AND THE SIZES FROM THE CONTRACT DOCUMENTS SHALL BE THE SAME AS THE SIZES FROM THE CONTRACT DOCUMENTS.
- 12. CONTRACTOR SHALL VERIFY ALL SIZES AND SIZES FROM THE CONTRACT DOCUMENTS AND THE SIZES FROM THE CONTRACT DOCUMENTS SHALL BE THE SAME AS THE SIZES FROM THE CONTRACT DOCUMENTS.
- 13. CONTRACTOR SHALL VERIFY ALL SIZES AND SIZES FROM THE CONTRACT DOCUMENTS AND THE SIZES FROM THE CONTRACT DOCUMENTS SHALL BE THE SAME AS THE SIZES FROM THE CONTRACT DOCUMENTS.
- 14. CONTRACTOR SHALL VERIFY ALL SIZES AND SIZES FROM THE CONTRACT DOCUMENTS AND THE SIZES FROM THE CONTRACT DOCUMENTS SHALL BE THE SAME AS THE SIZES FROM THE CONTRACT DOCUMENTS.
- 15. CONTRACTOR SHALL VERIFY ALL SIZES AND SIZES FROM THE CONTRACT DOCUMENTS AND THE SIZES FROM THE CONTRACT DOCUMENTS SHALL BE THE SAME AS THE SIZES FROM THE CONTRACT DOCUMENTS.
- 16. CONTRACTOR SHALL VERIFY ALL SIZES AND SIZES FROM THE CONTRACT DOCUMENTS AND THE SIZES FROM THE CONTRACT DOCUMENTS SHALL BE THE SAME AS THE SIZES FROM THE CONTRACT DOCUMENTS.
- 17. CONTRACTOR SHALL VERIFY ALL SIZES AND SIZES FROM THE CONTRACT DOCUMENTS AND THE SIZES FROM THE CONTRACT DOCUMENTS SHALL BE THE SAME AS THE SIZES FROM THE CONTRACT DOCUMENTS.
- 18. CONTRACTOR SHALL VERIFY ALL SIZES AND SIZES FROM THE CONTRACT DOCUMENTS AND THE SIZES FROM THE CONTRACT DOCUMENTS SHALL BE THE SAME AS THE SIZES FROM THE CONTRACT DOCUMENTS.
- 19. CONTRACTOR SHALL VERIFY ALL SIZES AND SIZES FROM THE CONTRACT DOCUMENTS AND THE SIZES FROM THE CONTRACT DOCUMENTS SHALL BE THE SAME AS THE SIZES FROM THE CONTRACT DOCUMENTS.
- 20. CONTRACTOR SHALL VERIFY ALL SIZES AND SIZES FROM THE CONTRACT DOCUMENTS AND THE SIZES FROM THE CONTRACT DOCUMENTS SHALL BE THE SAME AS THE SIZES FROM THE CONTRACT DOCUMENTS.
- 21. CONTRACTOR SHALL VERIFY ALL SIZES AND SIZES FROM THE CONTRACT DOCUMENTS AND THE SIZES FROM THE CONTRACT DOCUMENTS SHALL BE THE SAME AS THE SIZES FROM THE CONTRACT DOCUMENTS.
- 22. CONTRACTOR SHALL VERIFY ALL SIZES AND SIZES FROM THE CONTRACT DOCUMENTS AND THE SIZES FROM THE CONTRACT DOCUMENTS SHALL BE THE SAME AS THE SIZES FROM THE CONTRACT DOCUMENTS.

- 1. NOT USED
- 2. NOT USED
- 3. NOT USED
- 4. NOT USED
- 5. NOT USED
- 6. NOT USED
- 7. NOT USED
- 8. NOT USED
- 9. NOT USED
- 10. NOT USED
- 11. NOT USED
- 12. NOT USED
- 13. NOT USED
- 14. NOT USED
- 15. NOT USED
- 16. NOT USED
- 17. NOT USED
- 18. NOT USED
- 19. NOT USED
- 20. NOT USED
- 21. NOT USED
- 22. NOT USED

**GENERAL NOTES:**

THE BIDDERS SHALL VERIFY ALL SIZES AND SIZES FROM THE CONTRACT DOCUMENTS AND THE SIZES FROM THE CONTRACT DOCUMENTS SHALL BE THE SAME AS THE SIZES FROM THE CONTRACT DOCUMENTS.

**CONSTRUCTION LEGEND:**

- 1. CONSTRUCTION DOCUMENTS
- 2. CONTRACTOR'S FIELD NOTES
- 3. FIELD NOTES
- 4. FIELD NOTES
- 5. FIELD NOTES
- 6. FIELD NOTES
- 7. FIELD NOTES
- 8. FIELD NOTES
- 9. FIELD NOTES
- 10. FIELD NOTES
- 11. FIELD NOTES
- 12. FIELD NOTES
- 13. FIELD NOTES
- 14. FIELD NOTES
- 15. FIELD NOTES
- 16. FIELD NOTES
- 17. FIELD NOTES
- 18. FIELD NOTES
- 19. FIELD NOTES
- 20. FIELD NOTES
- 21. FIELD NOTES
- 22. FIELD NOTES

APP # 02-118049







**DETAIL NOT USED**

**C** FOURSQUARE  
GAX-2.1 NOT TO SCALE

**DETAIL NOT USED**

**DETAIL NOT USED**

**E** HOPSCOTCH  
GAX-2.1 NOT TO SCALE

**D** TETHERBALL COURT  
GAX-2.1 NOT TO SCALE

**B** VOLLEYBALL COURT  
GAX-2.1 NOT TO SCALE

**A** BASKETBALL COURT  
GAX-2.1 NOT TO SCALE

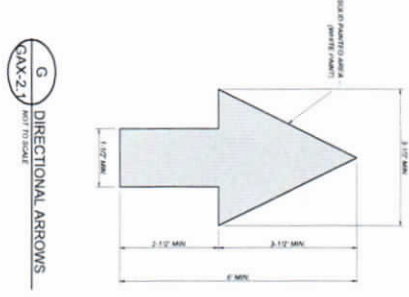
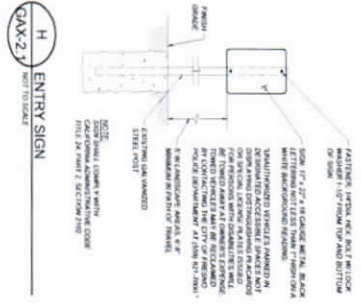
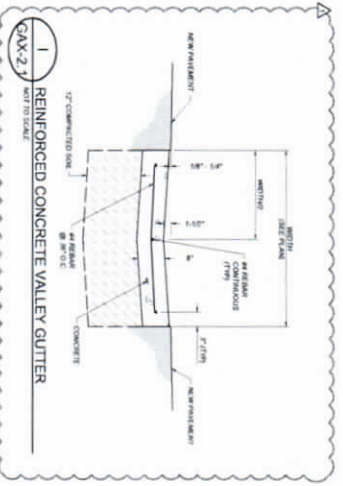

**F** TETHERBALL POSTS  
GAX-2.1 NOT TO SCALE

**DETAIL NOT USED**

		<b>Blair Church Hymn</b> CLOVIS UNIFIED SCHOOL DISTRICT	
2021 PAVEMENT REHABILITATION VARIOUS SITES GARFIELD ELEMENTARY SCHOOL DETAILS		CONST. DOCUMENTS <b>GAX-2.1</b>	

# CLOVIS UNIFIED SCHOOL DISTRICT

EIMEAR O'FARRELL, ED. D., DISTRICT SUPERINTENDENT

## PLANS FOR THE CONSTRUCTION OF 2021 PARKING LOT REHABILITATION IMPROVEMENTS AT REAGAN ELEMENTARY SCHOOL

DATE: 02-1-2021  
APP: # 02-1-1802



### LOCATION MAP

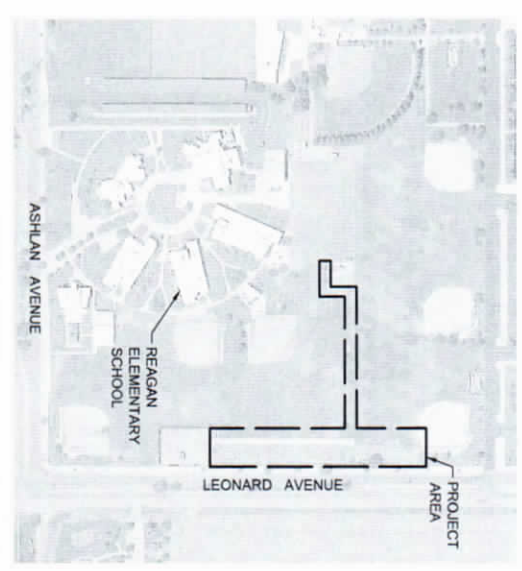

### SITE MAP

ADDRESS  
REAGAN ELEMENTARY SCHOOL  
CLOVIS, CA 93611

**PROJECT CONTACTS:**  
OWNER: CLOVIS UNIFIED SCHOOL DISTRICT  
CLOVIS, CA 93611  
PHONE: (559) 297-2000  
CONTRACTOR: EIMEAR O'FARRELL  
407 CLOVIS AVE, SUITE 200  
CLOVIS, CA 93611  
PHONE: (559) 297-1000

**SCOPE OF WORK:**  
1. REMOVE AND REPLACE ASPHALT PAVING LOT  
2. REMOVE AND REPLACE SIDEWALK ACCESSIBLE PAV  
3. RE-PAVING (ASPHALT)  
4. CURB CONCRETE WALKS AND ACCESSIBLE WALKING ACCESSIB  
5. NEW CHAIN LINK FENCING

**FLOOD HAZARD ZONE INFORMATION:**  
1. FLOOD ZONE DESIGNATION: ZONE X AREA OF SPECIAL FLOOD HAZARD  
2. FLOOD PREVENTION DATE: FEBRUARY 19, 2005

**APPLICABLE CODES:**  
2001 CALIFORNIA ZONING CODE, TITLE 24 PART 1 CODE  
2001 CALIFORNIA BUILDING CODE, TITLE 24 PART 2 CODE

**TABLE OF CONTENTS**

SHEET NUMBER	SHEET TITLE
RE-1	COVER SHEET
RE-2	ACCESS CONFORMANCE PLAN
RE-3	TOPOGRAPHIC SURVEY
RE-4.1	CONSTRUCTION PLAN
RE-5.1	UTILITY AND UTILIZATION PLAN
RE-6.1	GRADING AND DRAINAGE PLAN
RE-7.1	DETAILS
RE-8.2	DETAILS

TOTAL SHEET COUNT: 8



Blair Church Flynn  
CLOVIS UNIFIED SCHOOL DISTRICT



DATE: 02-1-2021  
APP: # 02-1-1802

CLOVIS UNIFIED SCHOOL DISTRICT  
VARIOUS SITES  
REAGAN ELEMENTARY SCHOOL  
COVER SHEET



CONSTRUCTION DOCUMENTS  
RE-1



SEE BOTTOM RIGHT



NOTE:  
THIS TOPOGRAPHIC SURVEY LOCATES SPECIFIC PHYSICAL FEATURES OF THE SITE AND THE ELEVATION AS DETERMINED NECESSARY FOR THE PROJECT. THE APPLICABLE SURVEYING METHODS AND DATA OBTAINED BY FIELD SURVEYING CONSIDERED ON PARAGRAPHS 4 & 5.19.

SITE BENCHMARK:  
APPROXIMATELY 4.50' CORNER OF CONCRETE CURB AND GROUND SURFACE.

PROJECT BENCHMARK:  
CONCRETE CURB ON CONCOURSE SIDE OF STREET AT PARALLEL TO PARALLEL TO STREET ELEVATION OF 4.50' CORNER OF CONCRETE CURB AND GROUND SURFACE.

UTILITY NOTE:  
UTILITY INFORMATION SHOWN HEREON IS BASED ON RECORD INFORMATION SUPPLIED TO THE ENGINEER BY THE UTILITY OWNERS AND CONTRACTORS AND IS NOT A FIELD SURVEY. THE ENGINEER HAS CONDUCTED VISUAL AND SURFACE CHECKS TO VERIFY THE LOCATION AND DEPTH OF UTILITIES AS SHOWN HEREON. THE CONTRACTOR SHALL VERIFY THE LOCATION AND DEPTH OF UTILITIES AND REQUEST THAT THE OWNER PROVIDE THE LOCATION OF ALL UNDERGROUND UTILITIES AT THE SITE.

**LEGEND:**

100.00	EXISTING ELEVATION
100.00	ASPHALT CONCRETE FLOOR
100.00	CONCRETE
100.00	CONCRETE EDGE
100.00	GRASS PAVEMENT
100.00	GUTTER FLOORING
100.00	STREET DRAIN CROSS CURB
100.00	TYPE OF CURB
100.00	WALLY GUTTER FLOORING
100.00	WALLY GUTTER
100.00	WALLY GUTTER (CONCRETE)
100.00	DOORWAY
100.00	WATER VALVE
100.00	MANHOLE
100.00	CONCRETE AND REINFORCEMENT
100.00	CONCRETE CURB AND GUTTER
100.00	CONCRETE CURB AND GUTTER
100.00	CONCRETE
100.00	WATER

SEE TOP LEFT

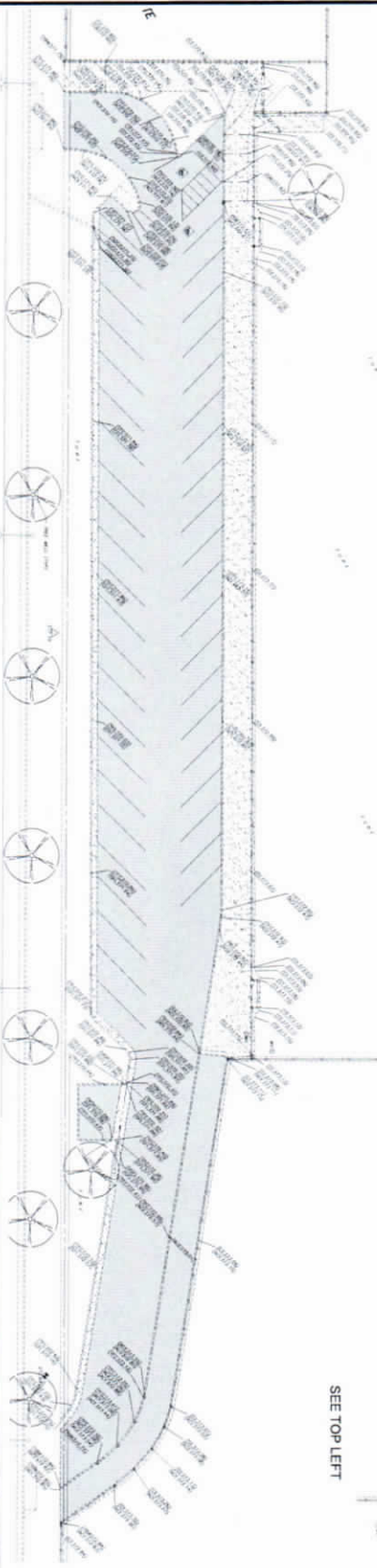

LEONARD AVENUE

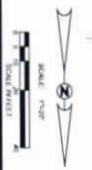

			2021 PAVEMENT REHABILITATION VARIOUS SITES REAGAN ELEMENTARY SCHOOL TOPOGRAPHIC SURVEY	CONST. DOCUMENTS RE-3
	CONTRACT DATE: APR. 4, 2024	SHEET NO.: 004-40-1	PROJECT NO.: 2021-004	DRAWN BY: [Name]

DATE: 04/04/24  
APP. # 02118002





SEE BOTTOM RIGHT

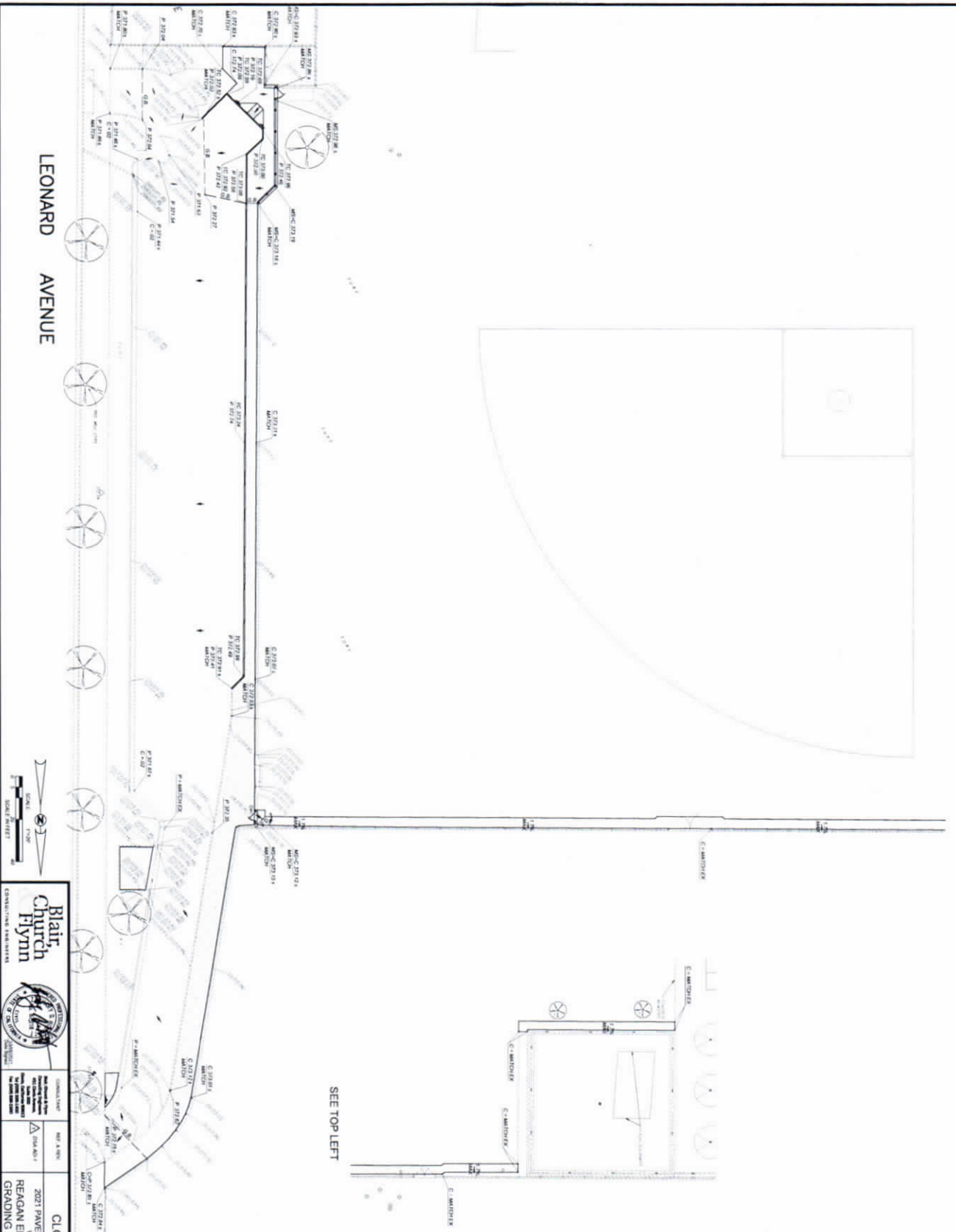

**GRADING LEGEND:**

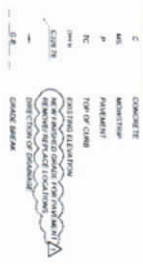

**GENERAL GRADING AND DRAINAGE NOTES:**

1. THE RECOMMENDATIONS AND INFORMATION SET OUT BELOW ARE PROVIDED FOR INFORMATION ONLY. THE CONTRACTOR SHALL BE RESPONSIBLE FOR THE PRODUCTION OF THE FINAL GRADING AND DRAINAGE PLAN AND SHALL BE RESPONSIBLE FOR OBTAINING ALL NECESSARY PERMITS AND APPROVALS.
2. THE CONTRACTOR SHALL BE RESPONSIBLE FOR VERIFYING THE ACCURACY OF ALL INFORMATION PROVIDED AND FOR OBTAINING ALL NECESSARY PERMITS AND APPROVALS.
3. THE CONTRACTOR SHALL BE RESPONSIBLE FOR OBTAINING ALL NECESSARY PERMITS AND APPROVALS.
4. THE CONTRACTOR SHALL BE RESPONSIBLE FOR OBTAINING ALL NECESSARY PERMITS AND APPROVALS.
5. THE CONTRACTOR SHALL BE RESPONSIBLE FOR OBTAINING ALL NECESSARY PERMITS AND APPROVALS.
6. THE CONTRACTOR SHALL BE RESPONSIBLE FOR OBTAINING ALL NECESSARY PERMITS AND APPROVALS.
7. THE CONTRACTOR SHALL BE RESPONSIBLE FOR OBTAINING ALL NECESSARY PERMITS AND APPROVALS.
8. THE CONTRACTOR SHALL BE RESPONSIBLE FOR OBTAINING ALL NECESSARY PERMITS AND APPROVALS.
9. THE CONTRACTOR SHALL BE RESPONSIBLE FOR OBTAINING ALL NECESSARY PERMITS AND APPROVALS.
10. THE CONTRACTOR SHALL BE RESPONSIBLE FOR OBTAINING ALL NECESSARY PERMITS AND APPROVALS.
11. THE CONTRACTOR SHALL BE RESPONSIBLE FOR OBTAINING ALL NECESSARY PERMITS AND APPROVALS.

**Blair Church Flynn**

CLOWIS UNIFIED SCHOOL DISTRICT  
2021 PAVEMENT REHABILITATION  
VARIOUS SITES  
REAGAN ELEMENTARY SCHOOL  
GRADING AND DRAINAGE PLAN

**811**  
Know what's below.  
Call before you dig.

CONST. DOCUMENTS  
RE-6.1





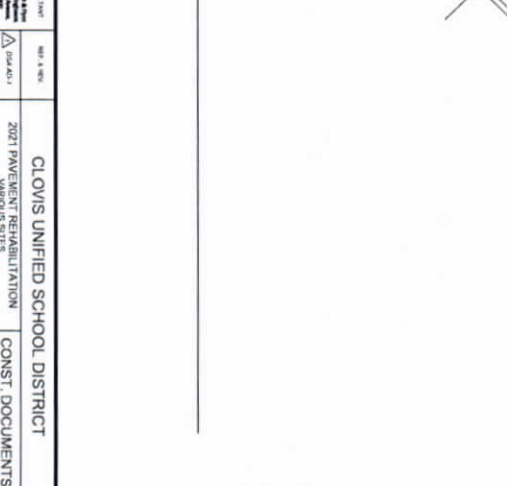
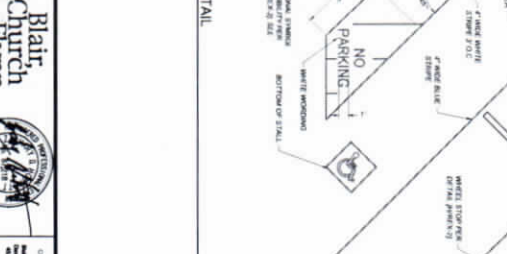
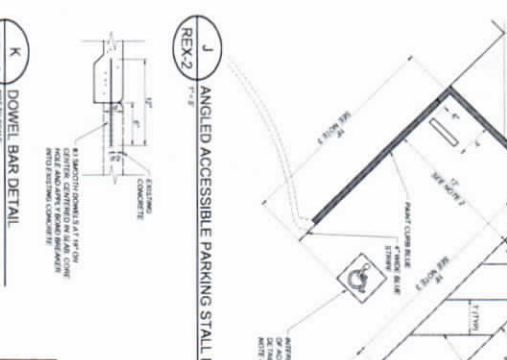
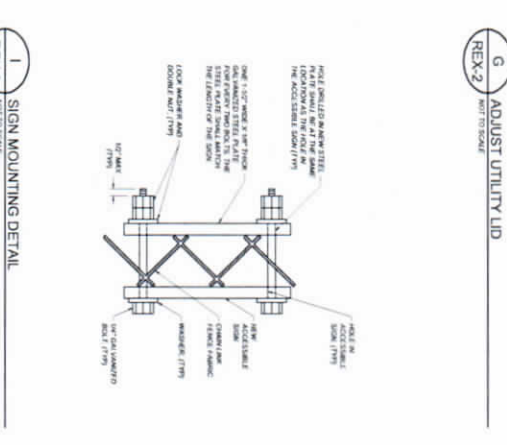
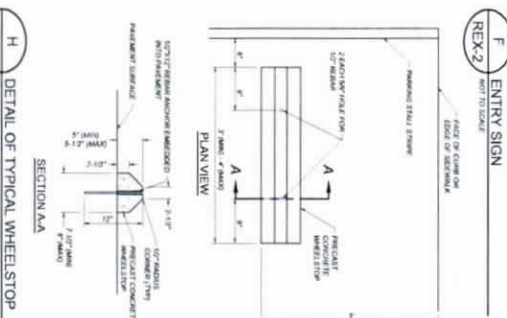
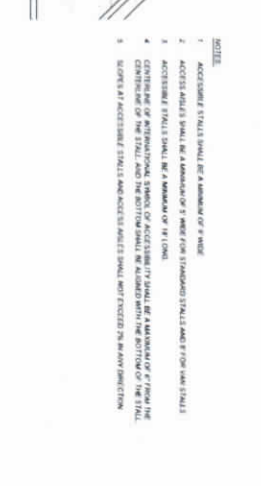
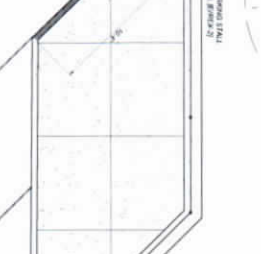
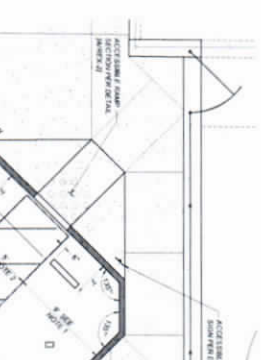
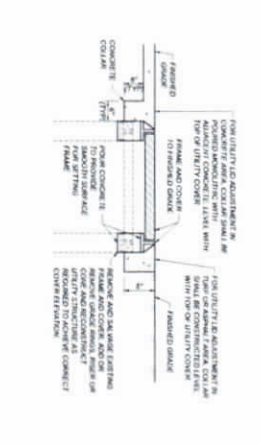
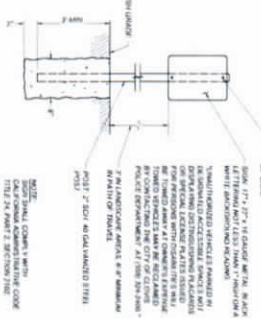
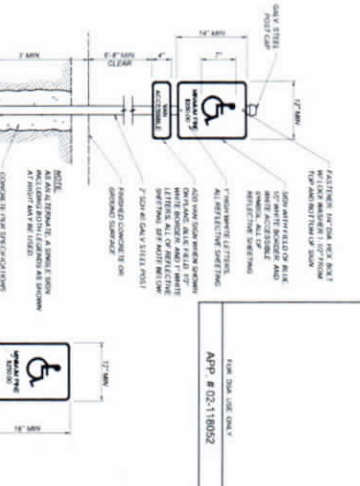
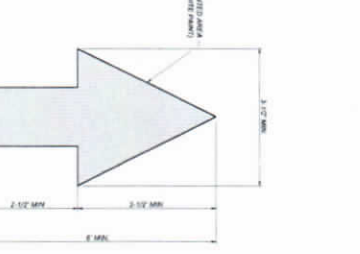
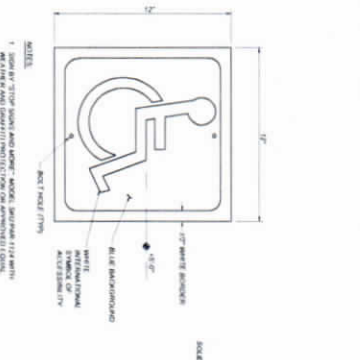
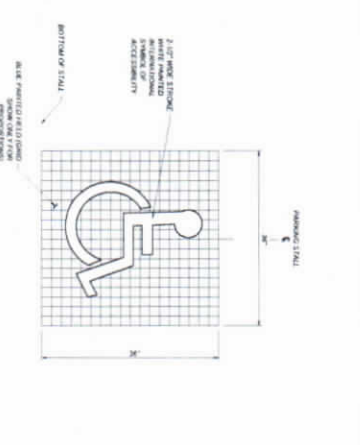
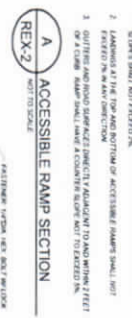
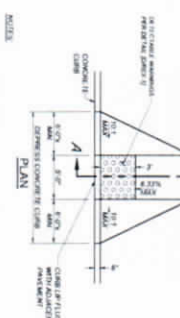
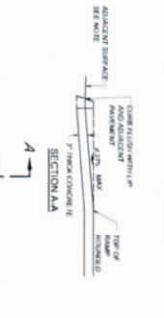

A ACCESSIBLE RAMP SECTION

B ACCESSIBLE SYMBOL

C ENTRY ACCESSIBILITY SIGN

D DIRECTIONAL ARROWS

E ACCESSIBLE PARKING STALL SIGN

F ENTRY SIGN

G ADJUST UTILITY LID

H DETAIL OF TYPICAL WHEELSTOP

I SIGN MOUNTING DETAIL

J ANGLED ACCESSIBLE PARKING STALL DETAIL

K DOWEL BAR DETAIL

L ACCESSIBLE RAMP SECTION

M SIGN MOUNTING DETAIL

N ADJUST UTILITY LID

O ANGLED ACCESSIBLE PARKING STALL DETAIL

P DOWEL BAR DETAIL

Q ACCESSIBLE RAMP SECTION

R SIGN MOUNTING DETAIL

S ADJUST UTILITY LID

T ANGLED ACCESSIBLE PARKING STALL DETAIL

<p>Blair Church Hymn</p>		<p>Blair Unified School District Const. Documents</p>	
<p>2021 PAVEMENT REHABILITATION WABOUS SITES REAGAN ELEMENTARY SCHOOL DETAILS</p>		<p>REAGAN ELEMENTARY SCHOOL DETAILS</p>	
<p>REAGAN ELEMENTARY SCHOOL DETAILS</p>		<p>REAGAN ELEMENTARY SCHOOL DETAILS</p>	

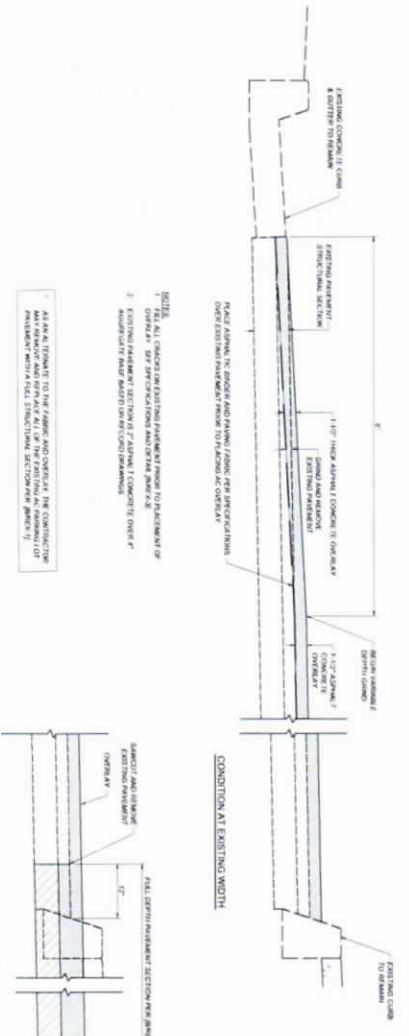

**A** EDGE-GRIND & C. OVERLAY WITH FABRIC<sup>®</sup>  
NOT TO SCALE  
REX-3

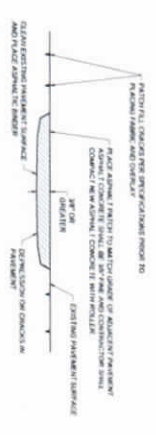

**B** CRACK PATCHING DETAIL  
NOT TO SCALE  
REX-3

<p>Blair Church Flynn</p>	<p>CITY OF CLOVIS</p>	<p>CLOVIS UNIFIED SCHOOL DISTRICT</p>
<p>CONTRACT NO. 2021-01-01</p> <p>DATE: 01/15/2021</p> <p>PROJECT: 2021 PAVEMENT REHABILITATION VARIOUS SITES</p>	<p>APP. A 001</p> <p>DATE: 01/15/2021</p> <p>PROJECT: 2021 PAVEMENT REHABILITATION VARIOUS SITES</p>	<p>2021 PAVEMENT REHABILITATION VARIOUS SITES</p> <p>REAGAN ELEMENTARY SCHOOL</p> <p>DETAILS</p>
<p>CONTRACT NO. 2021-01-01</p> <p>DATE: 01/15/2021</p> <p>PROJECT: 2021 PAVEMENT REHABILITATION VARIOUS SITES</p>	<p>APP. A 001</p> <p>DATE: 01/15/2021</p> <p>PROJECT: 2021 PAVEMENT REHABILITATION VARIOUS SITES</p>	<p>CONTRACT NO. 2021-01-01</p> <p>DATE: 01/15/2021</p> <p>PROJECT: 2021 PAVEMENT REHABILITATION VARIOUS SITES</p>

## AGREEMENT BETWEEN OWNER AND CONTRACTOR

THIS AGREEMENT, dated the \_\_\_\_\_ day of \_\_\_\_\_, 20\_\_\_\_, in the County of Fresno, State of California, is by and between Clovis Unified School District (hereinafter referred to as "DISTRICT"), and \_\_\_\_\_ (hereinafter referred to as "CONTRACTOR").

The DISTRICT and the CONTRACTOR, for the consideration stated herein, agree as follows:

1. The complete contract includes all of the Project documents described in the General Conditions. The Project documents are complementary, and what is called for by anyone shall be as binding as if called for by all.

2. CONTRACTOR shall perform within the time set forth in Paragraph 4 of this Agreement everything required to be performed, and shall provide and furnish all the labor, materials, necessary tools, expendable equipment, and all utility and transportation services as described in the complete contract and required for construction of

### **BID # 2848 Paving at Various Sites**

All of said work to be performed and materials to be furnished shall be completed in a good workmanlike manner in strict accordance with the plans, drawings, specifications and all provisions of the complete contract as hereinabove defined. The CONTRACTOR shall be liable to the DISTRICT for any damages arising as a result of a failure to fully comply with this obligation, and the CONTRACTOR shall not be excused with respect to any failure to so comply by any act or omission of the Architect, Engineer, Inspector, Division of State Architect, or representative of any of them, unless such act or omission actually prevents the CONTRACTOR from fully complying with the requirements of the Project documents, and unless the CONTRACTOR protests at the time of such alleged prevention that the act or omission is preventing the CONTRACTOR from fully complying with the Project documents. Such protest shall not be effective unless reduced to writing and filed with the DISTRICT within three (3) working days of the date of occurrence of the act or omission preventing the CONTRACTOR from fully complying with the Project documents.

3. DISTRICT shall pay to the CONTRACTOR, as full consideration for the faithful performance of the contract, subject to any additions or deductions as provided in the Project documents, the sum of \_\_\_\_\_ Dollars and \_\_ cents (\$\_\_\_\_\_)

4. The work shall be commenced on or before the fifth (5th) day after receiving the DISTRICT's Notice to Proceed and shall be completed within **75** calendar days.

5. Time is of the essence. If the work is not completed in accordance with Paragraph 4 above, it is understood that the DISTRICT will suffer damage. It being impractical and infeasible to determine the amount of actual damage, in accordance with Government Code Section 53069.85, it is agreed that CONTRACTOR shall pay to

DISTRICT as fixed and liquidated damages, and not as a penalty, the sum One Thousand Dollars (\$1000.00) for each calendar day of delay until work is completed and accepted. This amount shall be deducted from any payments due to or to become due to CONTRACTOR. CONTRACTOR and CONTRACTOR'S surety shall be liable for the amount thereof. Time extensions may be granted by the DISTRICT as provided in the General Conditions.

6. In the event CONTRACTOR for a period of ten (10) calendar days after receipt of written demand from DISTRICT to do so, fails to furnish tools, equipment, or labor in the necessary quantity or quality, or to prosecute said work and all parts thereof in a diligent and workmanlike manner, or after commencing to do so within said ten (10) calendar days, fails to continue to do so, then the DISTRICT may exclude the CONTRACTOR from the premises, or any portion thereof, and take possession of said premises or any portion thereof, together with all material and equipment thereon, and may complete the work contemplated by this Agreement or any portion of said work, either by furnishing the tools, equipment, labor or material necessary, or by letting the unfinished portion of said work, or the portion taken over by the DISTRICT to another contractor, or by a combination of such methods. In any event, the procuring of the completion of said work, or the portion thereof taken over by the DISTRICT, shall be a charge against the CONTRACTOR, and may be deducted from any money due or to become due to CONTRACTOR from the DISTRICT, or the CONTRACTOR shall pay the DISTRICT the amount of said charge, or the portion thereof unsatisfied. The sureties provided for under this Agreement shall become liable for payment should CONTRACTOR fail to pay in full any said cost incurred by the DISTRICT.

7. The CONTRACTOR agrees to and does hereby indemnify and hold harmless the DISTRICT, its governing board, officers, agents, and employees from every claim or demand made, and every liability, loss, damage, or expense, of any nature whatsoever, which may be incurred by reason of:

(a) Liability for damages for (1) death or bodily injury to persons; (2) injury to, loss or theft of property; or (3) any other loss, damage or expense arising under either (1) or (2) above, sustained by the CONTRACTOR upon or in connection with the work called for in this Project, except for liability resulting from the sole active negligence, or willful misconduct of the DISTRICT.

(b) Any injury to or death of any person(s) or damage, loss or theft of any property caused by any act, neglect, default or omission of the CONTRACTOR, or any person, firm, or corporation employed by the CONTRACTOR, either directly or by independent contract, arising out of, or in any way connected with the work covered by this Agreement, whether said injury or damage occurs on or off District property.

The CONTRACTOR, at CONTRACTOR's own expense, cost, and risk shall defend any and all actions, suits, or other proceedings that may be brought or instituted against the DISTRICT, its governing board, officers, agents or employees, on any such claim, demand or liability, and shall pay or satisfy any judgment that may be rendered against the DISTRICT, its governing board, officers, agents or employees in any action, suit or other proceedings as a result thereof.

8. CONTRACTOR shall take out, prior to commencing the work, and maintain, during the life of this contract, and shall require all subcontractors, if any, whether primary or secondary, to take out and maintain:

Public Liability Insurance for injuries including accidental death, to any one person or any one accident, in an amount not less than \$2,000,000.00;

Property Damage Insurance in an amount not less than \$2,000,000.00;

Insurance Covering Special Hazards: The following special hazards shall be covered by rider or riders to above-mentioned public liability insurance or property damage insurance policy or policies of insurance, or by special policies of insurance in amounts as follows:

Automotive and truck where operated in amounts as above

Material hoist where used in amounts as above

9. Public Contract Code Section 22300 permits the substitution of securities for any monies withheld by a public agency to ensure performance under a contract. At the request and expense of the CONTRACTOR, securities equivalent to the amount withheld shall be deposited with the public agency, or with a state or federally chartered bank in California as the escrow agent, who shall then pay such monies to the CONTRACTOR. The District retains the sole discretion to approve the bank selected by the CONTRACTOR to serve as escrow agent. Upon satisfactory completion of the contract, the securities shall be returned to the CONTRACTOR. Securities eligible for investment shall include those listed in Government Code Section 16430 or bank or savings and loan certificates of deposit. The CONTRACTOR shall be the beneficial owner of any securities substituted for monies withheld and shall receive any interest thereon.

In the alternative, under Section 22300, the CONTRACTOR may request DISTRICT to make payment of earned retentions directly to the escrow agent at the expense of the CONTRACTOR. Also, at the CONTRACTOR's expense, the CONTRACTOR may direct investment of the payments in securities, and the CONTRACTOR shall receive interest earned on such investment upon the same conditions as provided for securities deposited by CONTRACTOR. Upon satisfactory completion of the contract, CONTRACTOR shall receive from the escrow agent all securities, interest and payments received by escrow agent from DISTRICT pursuant to the terms of Section 22300. CONTRACTOR shall pay to each subcontractor, not later than 20 days after receipt of such payment, the respective amount of interest earned, net of costs attributed to retention withheld from each subcontractor, on the amount of retention withheld to insure performance of the CONTRACTOR.

10. Each and every provision of law and clause required by law to be inserted in this Agreement shall be deemed to be inserted herein and the Agreement shall be read and enforced as though it were included herein, and if through mistake or otherwise any such provision is not inserted, or is not currently inserted, then upon application of either party the Agreement shall forthwith be physically amended to make such insertion or correction.

11. The complete contract as set forth in Paragraph 1 of this Agreement constitutes the entire Agreement of the parties. No other agreements, oral or written, pertaining to the work to be performed, exists between the parties. This Agreement can be modified only by an amendment in writing, signed by both parties and pursuant to action of the Governing Board of the District.

12. The complete contract as set forth in Paragraph 1 of this Agreement constitutes the entire Agreement of the parties. No other agreements, oral or written, pertaining to the work to be performed, exists between the parties. This Agreement can be modified only by an amendment in writing, signed by both parties and pursuant to action of the Governing Board of the District.

13. CONTRACTOR shall comply with those provisions of the Labor Code requiring payment of prevailing wages, keeping of certified payroll records, overtime pay, employment of apprentices, and workers' compensation coverage, as further set forth in the General Conditions, and shall file the required workers' compensation certificate before commencing work.

IN WITNESS WHEREOF, the parties hereto have caused this Agreement to be executed.

**DISTRICT**

**CONTRACTOR**

By: \_\_\_\_\_  
Signature

By: \_\_\_\_\_  
Signature\* (see next p.)

Michael Johnston  
Associate Superintendent Admin Services

\_\_\_\_\_  
Title

(Second signature required only for corporation)

By: \_\_\_\_\_  
Signature\*\* (see next p.)

\_\_\_\_\_  
Print Name

\_\_\_\_\_  
Title

(CORPORATE SEAL OF CONTRACTOR, if corporation)

\_\_\_\_\_  
Contractor's License No.

\_\_\_\_\_  
Tax ID/Social Security No.

\*If CONTRACTOR is a corporation, the first signature must be by one of the following officers of the corporation: Chairman of the Board, President, or any Vice President.

\*\*If CONTRACTOR is a corporation, the second signature must be by a different person from the first signature and must be by one of the following officers of the corporation: Secretary, any Assistant Secretary, the Chief Financial Officer, or any Assistant Treasurer.

00700  
GENERAL CONDITIONS for GENERAL  
CONTRACTOR  
CLOVIS UNIFIED SCHOOL DISTRICT

**GENERAL CONDITIONS FOR GENERAL CONTRACTOR**

**ARTICLE 1. DEFINITIONS**

The following terms have the following meanings, notwithstanding that any such terms may be elsewhere defined in the Contract Documents. Any terms not expressly defined in this Article but defined in other portions of the Contract Documents have the respective meanings so given.

- (a) **Action of the Governing Board** is a vote of a majority of the membership in a lawful meeting.
- (b) **Addenda** are the changes in plans specifications, drawings, and Contract Documents which have been authorized in writing by the DISTRICT or ARCHITECT, and which alter, explain, or clarify the Contract Documents prior to the bid deadline. The Plan Review Agency responsible for plan review and approval will also review and approve the Addenda.
- (c) **Approval** means written authorization by ARCHITECT or DISTRICT, as appropriate, for specific applications. Approvals required by the Plan Review Agency shall mean written authorization by that agency.
- (d) **ARCHITECT** – The individual, or the assigned representative, who was retained by DISTRICT to prepare the bid documents: i.e., the construction plans and specifications. As used in these General Conditions, ARCHITECT may be a licensed Architect, Mechanical Engineer, Electrical Engineer, Civil Engineer, or any other design professional licensed in the State of California to provide design services.
- (e) **As shown, as indicated, and as detailed** refer to drawings accompanying the specification.
- (f) **As Directed, Accepted, Rejected, Approved** or others of similar meaning which authorize any exercise of judgment shall be distinctly understood to mean that such power to direct, accept, reject, and approve shall be vested only in DISTRICT and/or the ARCHITECT.
- (g) **Building** – Includes all structures, drives, and walks, steps, approaches and site.
- (h) **Called For** – As called for, shown, noted, and/or indicated in the specifications and/or drawings. (SEE ARTICLE 20, Drawings & Specifications)
- (i) **Contract** – All of the Contract Documents.
- (j) **Contract Documents** – Includes, collectively, to the extent applicable to the Project: Notice Calling for Bids/Notice to Contractors, Instructions to Bidders, Bid Form, Bid Bond or other statutory bid security, Request for Proposal, Request for Qualifications, Prime Bidder Good Faith Effort Worksheet, Prime Bidder Certificate, Pre-Construction Services Agreement, Roof Project Certification, Designation of Subcontractors, Workers' Compensation Certificate, Drug-Free Workplace Certification, Iran Contracting Act Certification, Change Orders, Shop Drawing Transmittals, any Information required of CONTRACTOR, any pre-qualification forms submitted, Sufficient Funds Declaration, Non-collusion Declaration, Faithful Performance Bond, Payment Bond, Insurance Certificates, Additional Insured Endorsements, Declarations Pages, Guarantees, Warranties, Fingerprinting Notice and Acknowledgement, Independent Student Contact Form, DVBE documentation, any Escrow Agreement, CONTRACTOR's Certificate Regarding Non-Asbestos Containing Materials, General Conditions, any Special Conditions, Plans, Drawings, Specifications, the Lease- Leaseback or Owner-Contractor Agreement (between DISTRICT and CONTRACTOR) and all



**00700  
GENERAL CONDITIONS for GENERAL  
CONTRACTOR  
CLOVIS UNIFIED SCHOOL DISTRICT**

modifications, addenda and amendments thereto, Site Lease, Sublease, and Lease and Sublease Agreement.

- (k) **Contract Sum** – The total amount payable by the DISTRICT to the CONTRACTOR as stated in the Agreement, including authorized adjustments, for performance of the Work. Can also be referred to as the Contract Cost.
- (l) **Contract Time** – The duration of the Project as defined in the Agreement.
- (m) **CONTRACTOR** or **DISTRICT** are those mentioned as such in the Agreement. They are treated throughout the Contract Documents as if they are of singular number and neutral gender.
- (n) **Days** – Days shall be considered calendar days.
- (o) **Deferred Approvals** – Deferred Approvals are items identified in the drawings and/or specifications that require the CONTRACTOR to prepare drawings and/or calculations and other data for submission to the Plan Review Agency for formal review and approval into the Contract Documents. For Deferred Approvals requiring a structural engineer's stamp and calculations, a structural engineer licensed in the State of California shall be utilized in the submittal process. The CONTRACTOR shall pay all costs associated with the preparation and approval of the deferred approvals.
- (p) **Delay Days** – Delay Days shall be considered working days. Assuming a 5-day workweek, delay days shall be converted into calendar days by a factor of 1.4. Hence 10 Delay Days = 14 Calendar Days. Delay Days will be evaluated and identified as one of the three categories listed below. Excusable delays will create adjustments in the Contract Time. Compensable delays will create adjustments in both the Contract Sum and Contract Time. In the event of Concurrent Delays, no delay damages are recoverable by either the DISTRICT or the CONTRACTOR, and no extension of time shall be granted for Concurrent Delays. Concurrent Delays shall be evaluated using schedule updates, daily reports, notices, and any other records of delaying events. In the event of a delay, the CONTRACTOR shall provide a "Notice of Delay" within 24 hours of the *delaying* event, and submit a schedule depicting the delay with all substantiating documentation within **seven (7) days** of the *delaying* event.

<u>Excusable &amp; Compensable</u>	<u>Excusable &amp; Non-Compensable</u>	<u>Inexcusable</u>
Delays caused by the DISTRICT, the ARCHITECT, or the DISTRICT'S forces or separate contractors	<ol style="list-style-type: none"> <li>1. Unusually severe weather</li> <li>2. Strikes or labor shortages</li> <li>3. Acts of God</li> <li>4. Fires, war, Acts of government &amp; pestilence</li> </ol>	Delays caused by the CONTRACTOR, Subcontractor(s), materialmen, or suppliers, including concurrent delays.

- (q) **DISTRICT or Owner** – As indicated in the Bid Form, Notice to Contractors and the AGREEMENT.
- (r) **Equipment and/or Furnishing Modifiers:**

**F.B.O.** – Where the indication "F.B.O." is noted on the drawings or listed in the specifications, such item(s) are shown or listed for information and will be "Furnished by OWNER or OTHERS" and installed by CONTRACTOR. The CONTRACTOR shall verify all dimensions and details necessary for the proper installation.

00700  
GENERAL CONDITIONS for GENERAL  
CONTRACTOR  
CLOVIS UNIFIED SCHOOL DISTRICT

**N.I.C.** – Where the indication "N.I.C." is noted on the drawings or listed in the specifications, such item(s) is/are shown or listed for the purpose of general information and is/are "Not in Contract." Installation and connection to services for such work are not in the contract; however coordination is required by CONTRACTOR for utility service locations and/or connection types.

**I.C.** – "IN CONTRACT": All item(s) shown or listed in the drawings and specifications are in the Contract and are part of the Work. The naming of any item(s) shall mean to provide the item(s), that is furnishing (including all incidental and accessory items thereto) and installing (including all labor necessary to achieve full and complete functioning of the item(s) according to the best practices of the trades involved).

When and if the indication "I.C." is noted on the drawings or listed in the specifications, such a designation is listed only for clarity, in order to set the item(s) apart from the "F.B.O." and "N.I.C." item(s).

- (s) **Locality** in which the Work is performed means the city and/or county in which the public work is done.
- (t) **Materials** – Materials incorporated in the project or used or consumed in the performance of the Work.
- (u) **Plan Review Agency** is the agency responsible for the review and approval of the Plans, Specifications, Addenda, Substitution Requests (if appropriate), Change Orders, and the alike.
- (v) **Project** is the planned undertaking as provided for in the Contract Documents, possibly including construction by separate contractors.
- (w) **Provide** shall include "provide complete in place," that is, "furnish and install."
- (x) **Safety Orders** are those issued by the Division of Industrial Safety and OSHA safety and health standards for construction.
- (y) **Shop Drawings and Submittals** - They are generally treated throughout the Contract Documents as if they are one and the same.
- (z) **Similar** – Shall be taken in its general sense and not meaning identical, and all details of such work shall be in proper relation to the location and connection of other parts of the Work.
- (aa) **Standards, Rules, and Regulations** referred to are recognized printed standards and shall be considered as one and a part of these specifications within limits specified.
- (bb) **Subcontractor**, as used herein, includes those having a direct contractual relationship with CONTRACTOR and one who furnishes material worked to a special design according to plans, drawings, and specifications of this Work, but does not include one who merely furnishes material not so worked.
- (cc) **Surety** is the person, firm, or corporation that executes as surety the CONTRACTOR's Bid Security, faithful performance bond and/or payment bond.
- (dd) **Work** of the CONTRACTOR or Subcontractor includes labor or materials (including, without limitation, equipment and appliances) or both, incorporated in, or to be incorporated in the construction covered by the Contract, including, but not limited to, punch list items. The Work shall constitute a "work of improvement" under Civil Code section 8050 and Public Contract Code section 7107.

00700  
GENERAL CONDITIONS for GENERAL  
CONTRACTOR  
CLOVIS UNIFIED SCHOOL DISTRICT

- (ee) **Workers** include laborers, workers, and mechanics.
- (ff) **CONSTRUCTION ADMINISTRATION DOCUMENTS: Terms, uses and protocols.**  
Notwithstanding any other provisions in the General Conditions, the following terms and definitions shall be used by all Architects, Engineers and Contractors and shall conform to "Constructware" terms. Architects, Engineers and Contractors shall utilize the Constructware software program to enter and process all Administration documents, including but not limited to those listed below, payment-related documents and other documents referenced throughout. The Constructware software, log-in credentials and training for the Constructware software program will be provided by the District upon request.
- (1) **RFI** – The term "RFI" shall mean Request for Information. An RFI is a written instrument prepared by the CONTRACTOR and submitted to the ARCHITECT. An RFI shall be considered a tool for requesting additional information, above and beyond that which is available in the Contract Documents and all reference standards, and fulfilling the Contract coordination requirements for which CONTRACTOR is obligated to perform. The RFI shall not be used for requesting design and/or material substitutions.

Prior to issuing an RFI the CONTRACTOR, Subcontractor, material suppliers and the like shall thoroughly review the Contract Documents and refer to all reference standards for the information sought.

When submitting an RFI, the document shall specify the date issued and the date the information is needed by. However the contractual response time shall be **fourteen (14) days** from the date the ARCHITECT receives the RFI, unless more time is needed under the circumstances. The CONTRACTOR shall plan its work and submit questions in sufficient time to accommodate the response time. If the Contract requires a CPM schedule, the CONTRACTOR shall include in the RFI the CPM Activity Number and the originating Subcontractor.

The CONTRACTOR shall make efforts to coordinate the Work in a timely fashion, so as to alleviate priority RFI's. If the RFI is considered a priority, the CONTRACTOR shall state the word "Priority" on the document, and the CONTRACTOR shall provide weekly RFI Priority Schedules. The CONTRACTOR shall issue and maintain weekly RFI Priority Schedules.

The RFI Priority Schedule shall include a listing of pending requests, including the most current request, and rank the RFI's in order of priority. The ARCHITECT shall endeavor to respect the CONTRACTOR's requested order of priorities and requested response dates.

The ARCHITECT and/or Engineer's response to the RFI shall be considered a Supplemental Instruction (SI) in which the Contract Sum and/or Time is not altered. If the RFI response alters the Contract Sum and/or Time, a Construction Change Directive (CCD) or a Request for Proposal (RFP) may be issued for the changed condition(s).

Should the CONTRACTOR determine the response to the RFI creates changes in the Contract Sum and/or Time, the CONTRACTOR shall submit a change order request (COR) to the ARCHITECT for review, along with a Time Extension Request (if required)

- (2) **SI** – The term "SI" shall mean Supplemental Instruction. The SI is a written instrument prepared by the ARCHITECT and submitted to the CONTRACTOR. The SI can order changes in the Work that does not affect the Contract Sum and/or Time. Supplemental Instructions can also be made in a RFI response by issuing a formal SI document or by written letter from the ARCHITECT'S office.
- (3) **RFP** – The term "RFP" shall mean Request for Proposal. The RFP is a written instrument prepared by the ARCHITECT and submitted to the CONTRACTOR. The RFP is a request for

00700

**GENERAL CONDITIONS for GENERAL  
CONTRACTOR  
CLOVIS UNIFIED SCHOOL DISTRICT**

changes in the Contract Sum and/or Time, for potential changed Contract conditions, for which the Contract Sum and/or Time may or may not be affected. As appropriate, the CONTRACTOR shall provide the full and complete terms of the request in a Change Order Request (COR)

within **ten (10) days** of receipt of the RFP: If the RFP results in added time the CONTRACTOR shall provide a Time Extension Request within the same **ten (10) days**. If the DISTRICT accepts the full terms of the RFP, the RFP shall be incorporated into a Construction Change Directive (CCD) and/or a Change Order (CO), and the approved Time Extension, if any, shall become incorporated into the next monthly schedule update to reflect the time impact(s).

- (4) **CCD** – The term “CCD” shall mean Construction Change Directive. The CCD is a written instrument prepared by the ARCHITECT and submitted to the CONTRACTOR. The CCD is a written order directing a change in the Work and stating the required pricing method, if any, in the Contract Sum, and the Contract Time adjusted to reflect a previously approved Time Extension Request, if any.

The CCD, without invalidating the Contract, may order changes in the Work within the general scope of the Contract, consisting of additions, deletions, or other revisions within. The CCD shall become effective when the ARCHITECT, CONTRACTOR, AND OWNER have signed the CCD.

- (5) **COR** – The term “COR” shall mean Change Order Request. The COR is a written instrument prepared by the CONTRACTOR and submitted to the ARCHITECT. The COR is the CONTRACTOR’s method for requesting the full and complete terms for changes in the Contract Sum and/or Time, if any. All of the terms of the COR need to be identified, and without reservations, so that the DISTRICT and/or ARCHITECT can consider the full impact of the COR. The provisions and format of the request are identified under Article entitled **CHANGES AND EXTRA WORK**. ARCHITECT shall endeavor to respond to the COR on or within **fourteen (14) days** of receipt.

- (6) **CO** – The term “CO” shall mean Change Order. The Change Order shall state the change in Work and the Contract Sum and/or Time adjustments, if any. RFP’s and/or CCD’s may be incorporated into a Change Order, after any adjustments in the Contract Sum and/or Time have been reviewed and accepted by the DISTRICT and ARCHITECT. The Change Order, and items contained therein, cannot be incorporated into the progress payments until the Change Order has been fully executed and accepted the Governing Board. Upon the Governing Board’s approval, the ARCHITECT will issue the fully executed Change Order to the Plan Review Agency responsible for plan review and approval for written approval of the Change Order.

**ARTICLE 2. STATUS OF CONTRACTOR**

- (a) CONTRACTOR is and shall at all times be deemed to be an independent CONTRACTOR and shall be wholly responsible for the manner in which it performs the services required of it by the terms of the Contract Documents. Nothing herein contained shall be construed as creating the relationship of employer and employee, or principal and agent, between the DISTRICT and CONTRACTOR or any of CONTRACTOR’s agents, employees, or Subcontractors. CONTRACTOR assumes exclusively the responsibility for the acts of its employees and Subcontractors as they relate to the services to be provided during the course and scope of their employment. CONTRACTOR, its agents and employees and Subcontractors shall not be entitled to any rights or privileges of DISTRICT employees and shall not be considered in any manner to be DISTRICT employees. DISTRICT shall be permitted to monitor the activities of the CONTRACTOR to determine compliance with the terms of the Contract Documents.
- (b) CONTRACTOR (including all subcontractors) is required by law to be licensed and regulated by the Contractors’ State License Board. Any CONTRACTOR not so licensed is subject to penalties under the law, and the contract will be considered void pursuant to Section 7028.7 of

00700

**GENERAL CONDITIONS for GENERAL  
CONTRACTOR  
CLOVIS UNIFIED SCHOOL DISTRICT**

the Business and Professions Code. Any questions concerning a CONTRACTOR may be referred to the Registrar, Contractors' State License Board, 9821 Business Park Drive, Sacramento, CA 95827.

**ARTICLE 3. CHANGE IN NAME AND NATURE OF CONTRACTOR'S LEGAL ENTITY**

- (a) Before CONTRACTOR makes any change in the name or legal nature of the CONTRACTOR's entity, CONTRACTOR shall first notify the DISTRICT in writing and cooperate with DISTRICT in making such changes as the DISTRICT may request in the Contract Documents regarding possible change in Ownership, Principals, or Officers.

**ARTICLE 4. CONTRACTOR'S SUPERVISION, PROSECUTION, AND PROGRESS**

- (a) During progress of the Work, CONTRACTOR shall keep on the Work site a competent superintendent satisfactory to DISTRICT, who shall remain on the Work site during the performance of the CONTRACTOR's Work and for the necessary coordination thereof. Before commencing the Work herein, CONTRACTOR shall give written notice to DISTRICT and ARCHITECT of the name, qualifications and experience of such superintendent. If the superintendent is found unsatisfactory by DISTRICT, CONTRACTOR shall replace the superintendent with one acceptable to the DISTRICT. Superintendent shall not be changed or removed from the project except with written consent of DISTRICT, unless a superintendent proves to be unsatisfactory to CONTRACTOR and ceases to be in its employ, in which case, CONTRACTOR shall notify DISTRICT and ARCHITECT in writing and replace said superintendent with one acceptable to the DISTRICT. Superintendent shall represent CONTRACTOR and all directions given to superintendent shall be as binding as if given to CONTRACTOR.
- (b) CONTRACTOR shall supervise and direct the Work competently and efficiently, devoting such attention thereto and applying such skills as may be necessary to perform the Work in accordance with the Contract Documents. CONTRACTOR shall carefully study and compare all plans, drawings, specifications, and other instructions and shall at once report to ARCHITECT any error, inconsistency, or omission which CONTRACTOR or its employees may discover. The CONTRACTOR represents itself to DISTRICT as a skilled, knowledgeable, and experienced CONTRACTOR. The CONTRACTOR shall be liable to the DISTRICT for damage resulting from errors, inconsistencies, or omissions in the Contract Documents that the CONTRACTOR knew about or that an experienced CONTRACTOR would have recognized and which CONTRACTOR did not report.
- (c) The CONTRACTOR shall verify all indicated dimensions before ordering materials or equipment, or before performing work. The CONTRACTOR shall take field measurements, verify field conditions, and shall carefully compare such field measurements and conditions and other information known to the CONTRACTOR with the Contract Documents before commencing work. Errors, inconsistencies, or omissions discovered shall be reported to the DISTRICT and ARCHITECT at once. Upon commencement of any item of work, the CONTRACTOR shall be responsible for dimensions related to such item of work and shall make any corrections necessary to make work properly fit at no additional cost to DISTRICT. This responsibility for verification of dimensions is a non-delegable duty and may not be delegated to Subcontractors or agents.
- (d) Omissions from the plans, drawings or specifications, or the mis-description of customary and usual details of work which are manifestly necessary to carry out the work, or which are customarily performed, shall not relieve the CONTRACTOR from performing such omitted or mis-described work, but they shall be performed as if fully and correctly set forth and described in the plans, drawings and specifications.

**00700**  
**GENERAL CONDITIONS for GENERAL**  
**CONTRACTOR**  
**CLOVIS UNIFIED SCHOOL DISTRICT**

- (e) The CONTRACTOR shall be solely responsible for the means, methods, techniques, sequences, and procedures of construction. The CONTRACTOR shall be responsible for the construction schedule and overall sequence of construction. The CONTRACTOR shall insure that the finished Work complies with the Contract Documents.
- (f) Pursuant to Public Contract Code section 6109, no CONTRACTOR may perform work on a public works project with a subcontractor who is ineligible to perform work on the project pursuant to sections 1777.1 or 1777.7 of the Labor Code.
- (g) DISTRICT shall have the right, but not the obligation, to require the removal from the Work of any superintendent, staff member, agent, or employee of the CONTRACTOR, any subcontractor, material or equipment supplier, etc., for cause.
- (h) CONTRACTOR shall attend DISTRICT's Project meetings as scheduled by the Contract Documents, or as otherwise instructed by Owner, to discuss the current status of the Project and the future progress of the Work. Contractor shall have five (5) days after receipt of Owner's Project meeting minutes to provide written objections and suggested corrections.

**ARTICLE 5. SUBCONTRACTORS**

- (a) CONTRACTOR agrees to bind every Subcontractor by terms of the Contract Documents as far as such terms are applicable to Subcontractor's work. If CONTRACTOR subcontracts any part of the Work, CONTRACTOR shall be as fully responsible to DISTRICT for acts and omissions of any Subcontractor and of persons either directly or indirectly employed by any Subcontractor, as it is for acts and omissions of persons directly employed by CONTRACTOR. Nothing contained in Contract Documents shall create any contractual relation between any Subcontractor and DISTRICT, nor shall the Contract Documents be construed to be for the benefit of any Subcontractor.
- (b) DISTRICT's consent to any Subcontractor shall not in any way relieve CONTRACTOR of any obligations under the Contract Documents and no such consent shall be deemed to waive any provision of the Contract Documents.
- (c) CONTRACTOR must submit with its bid, a Designation of Subcontractors pursuant to the Subletting and Subcontracting Fair Practices Act. If CONTRACTOR specifies more than one Subcontractor for the same portion of Work or fails to specify a Subcontractor, and such portion of the Work exceeds one-half of one percent of the total bid, CONTRACTOR agrees that it is fully qualified to perform and shall perform such work itself, unless CONTRACTOR provides for substitution or addition of Subcontractors. Substitution or addition of Subcontractors shall be permitted only as authorized under the Subletting and Subcontracting Fair Practices Act, California Public Contract Code Section 4100, et. seq.
- (d) In accordance with California Business and Professions Code Section 7059, if CONTRACTOR is designated as a "specialty CONTRACTOR" (as defined in Section 7058 of the Public Contract Code), all of the work to be performed outside of the CONTRACTOR's license specialty shall be performed by a licensed Subcontractor in compliance with the Subletting and Subcontracting Fair Practices Act, California Public Contract Code Section 4100, et seq.
- (e) A copy of each bid sheet, if in writing, or, if not in writing, then a written statement signed by the CONTRACTOR giving the name of the Subcontractor and the terms and conditions of such subcontract, shall be filed with the DISTRICT before the CONTRACTOR begins Work. Each subcontract shall contain a reference to the Agreement between the DISTRICT and the CONTRACTOR and the terms of that Agreement and all parts of the Contract Documents shall be made a part of such subcontract insofar as applicable to the work covered thereby. Each

**00700**  
**GENERAL CONDITIONS for GENERAL**  
**CONTRACTOR**  
**CLOVIS UNIFIED SCHOOL DISTRICT**

subcontract will provide for termination in accordance with the Article entitled DISTRICT'S RIGHT TO TERMINATE AGREEMENT of these General Conditions. Each subcontract shall provide for its annulment by the CONTRACTOR at the order of the ARCHITECT if in the ARCHITECT's opinion the Subcontractor fails to comply with the requirements of the Contract Documents insofar as the same may be applicable to this Work. Nothing herein contained shall relieve the CONTRACTOR of any liability or obligation hereunder.

- (f) The CONTRACTOR agrees that the State and DISTRICT have the right to review, obtain, and copy all records pertaining to performance of the contract. The CONTRACTOR agrees to provide the State or the DISTRICT with any relevant information requested and shall permit the State or the DISTRICT access to its premises upon reasonable notice for purposes of interviewing employees and inspecting records. The CONTRACTOR agrees to maintain such records for a period of three years after final payment under the contract.
- (g) Each subcontract agreement for a portion of the Work is assigned by the CONTRACTOR to the DISTRICT provided that:
  - A. Assignment is effective only after termination of the Contract Documents with the CONTRACTOR by the DISTRICT for cause and only for those subcontract agreements which the DISTRICT accepts by notifying the Subcontractor in writing; and
  - B. Assignment is subject to the prior rights of the surety, if any, obligated under any bond relating to the Contract Documents.

**ARTICLE 6. PROHIBITED INTERESTS**

- (a) No official of DISTRICT who is authorized in such capacity and on behalf of DISTRICT to negotiate, make, accept, or approve, or to take part in negotiating, making, accepting or approving any architectural, engineering, inspection, construction or material supply contract or any subcontract in connection with construction of the Project, may be or become directly or indirectly interested financially in this Project or in any part thereof. No officer, employee, ARCHITECT, attorney, engineer or inspector of or for DISTRICT who is authorized in such capacity and on behalf of DISTRICT to exercise any executive, supervisory or other similar functions in connection with construction of Project may be or become directly or indirectly interested financially in this Project or in any part thereof. CONTRACTOR shall receive no compensation and shall repay DISTRICT for any compensation received by CONTRACTOR hereunder, should CONTRACTOR aid, abet or knowingly participate in violation of this Article.

**ARTICLE 7. DISTRICT'S INSPECTOR**

- (a) One or more Inspector(s), including special inspectors, as required, will be employed by DISTRICT in accordance with the requirements of Title 24, Part 1 of the California Code of Regulations and will be assigned to the Project. Duties of an Inspector are specifically defined in Section 4-342 of Title 24, 2007 California Administrative Code.
- (b) No work shall be performed by the CONTRACTOR solely upon the instructions or comments by the Inspector. The Inspector has no authority to interpret the Contract Documents or order extra work and any extra work performed without the written instruction of the DISTRICT shall be at CONTRACTOR's sole cost and expense and there will be no delay damages incurred by DISTRICT for such work.
- (c) No work shall be carried on except with the knowledge and under the inspection of the Inspector(s). The Inspector shall have free and adequate access to any or all parts of Work at any time. CONTRACTOR shall furnish Inspector reasonable opportunities and equipment

00700  
GENERAL CONDITIONS for GENERAL  
CONTRACTOR  
CLOVIS UNIFIED SCHOOL DISTRICT

necessary for obtaining such information as may be necessary to keep Inspector fully informed respecting progress and manner of work and character of materials. Inspection of Work shall not relieve CONTRACTOR from any obligation to fulfill the Contract Documents. The DISTRICT shall have authority to stop work whenever provisions of Contract Documents are not being complied with and such noncompliance is discovered. CONTRACTOR shall instruct its employees accordingly.

**ARTICLE 8. ARCHITECT'S STATUS**

- (a) The ARCHITECT
- (1) The ARCHITECT shall be one of the DISTRICT's representatives during construction and shall observe the progress and quality of the Work on behalf of the DISTRICT. ARCHITECT shall have the authority to act on behalf of DISTRICT only to the extent expressly provided in the Contract Documents. ARCHITECT shall have authority to stop Work whenever such stoppage may be necessary in ARCHITECT's reasonable opinion to insure the proper execution of the Contract Documents.
  - (2) The ARCHITECT shall be, in the first instance, the judge of the performance of the Work. ARCHITECT shall exercise authority under the Contract Documents to enforce CONTRACTOR's faithful performance.
  - (3) The ARCHITECT shall have all authority and responsibility established by law, including Title 24 of the California Code of Regulations. The ARCHITECT has the authority to enforce compliance with the Contract Documents and the CONTRACTOR shall promptly comply with instructions from the ARCHITECT or an authorized representative of the ARCHITECT.
  - (4) On all questions related to the quantities, the acceptability of material, equipment or workmanship, the execution, progress or sequence of Work, the interpretation of plans, specifications or drawings, and the acceptable performance of the CONTRACTOR, the decision of the ARCHITECT shall govern and shall be precedent to any payment unless otherwise ordered by the Governing Board. The progress and completion of the Work shall not be impaired or delayed by virtue of any question or dispute arising out of or related to the foregoing matters and the instructions of the ARCHITECT relating thereto.
  - (5) General supervision and direction of the Work by the ARCHITECT shall in no way imply that the ARCHITECT or its representatives are in any way responsible for the safety of the CONTRACTOR or its employees or that the ARCHITECT or its representatives will maintain supervision over the CONTRACTOR's construction methods or personnel other than to ensure that the quality of the finished Work is in accordance with the Contract Documents.

**ARTICLE 9. NOTICE OF TAXABLE POSSESSORY INTEREST**

- (a) The terms of the Agreement may result in the creation of a possessory interest. If such a possessory interest is vested in a private party to the Agreement, the private party may be subjected to the payment of property taxes levied on such interest.

**ARTICLE 10. ASSIGNMENT OF ANTITRUST ACTIONS**

- (a) Public Contract Code Section 7103.5 provides:
- (1) In entering into a public works contract or a subcontract to supply goods, services, or materials pursuant to a public works contract, the CONTRACTOR or Subcontractor offers and agrees to assign to the awarding body (DISTRICT) all rights, title, and interest in and to



**00700**  
**GENERAL CONDITIONS for GENERAL**  
**CONTRACTOR**  
**CLOVIS UNIFIED SCHOOL DISTRICT**

all causes of action it may have under Section 4 of the Clayton Act (15 U.S.C. Section 15) or under the Cartwright Act (Chapter 2 (commencing with Section 16700) of Part 2 of Division 7 of the Business and Professions Code), arising from purchases of goods, services, or materials pursuant to the public works contract or the subcontract. This assignment shall be made and become effective at the time the awarding body tenders final payment to the CONTRACTOR, without further acknowledgment by the parties.

- (2) CONTRACTOR, for itself and all Subcontractors, agrees to assign to DISTRICT all rights, title, and interest in and to all such causes of action CONTRACTOR and all Subcontractors may have under the Contract Documents. This assignment shall become effective at the time DISTRICT tenders final payment to the CONTRACTOR and CONTRACTOR shall require assignments from all Subcontractors to comply herewith.

**ARTICLE 11. OTHER CONTRACTS**

- (a) CONTRACTOR is aware that this Project site may be split into several phases and/or separate contracts. DISTRICT reserves the right to let other contracts in connection with this Work, and it shall be the duty of the CONTRACTOR to actively schedule and coordinate its work with the DISTRICT's forces or other contractors. No extra costs or delays shall be considered as a result of any such scheduling, coordination and cooperation. CONTRACTOR shall afford other contractors reasonable opportunity for introduction and storage of their materials and execution of their work and shall properly connect and coordinate its work with such other contractors.
- (b) If any part of CONTRACTOR's Work depends for proper execution or results upon work of any other Contractor, the CONTRACTOR shall inspect and promptly report to ARCHITECT in writing any defects in such work that render it unsuitable for such proper execution and results. CONTRACTOR will be held accountable for damages to DISTRICT for that work which it failed to inspect or should have inspected. CONTRACTORS' failure to inspect and report shall constitute its acceptance of other Contractor's work as fit and proper for reception of its work, except as to defects which may develop in other Contractors' work after execution of CONTRACTOR's work.
- (c) To insure proper execution of its subsequent work, CONTRACTOR shall measure and inspect work already in place and shall at once report to the ARCHITECT in writing any discrepancy between executed work and Contract Documents.
- (d) It is the obligation of CONTRACTOR to ascertain to its own satisfaction the scope of the Project and nature of any other contracts that have been or may be awarded by DISTRICT in prosecution of the Project to the end that CONTRACTOR may perform its Contract in the light of such other contracts, if any.
- (e) Nothing herein contained shall be interpreted as granting to CONTRACTOR exclusive occupancy of the Project. CONTRACTOR shall not cause any unnecessary hindrance or delay to any other contractor working on the Project. If simultaneous execution of any contract for the Project is likely to cause interference with performance of some other contract or contracts, DISTRICT shall decide which contractor shall cease work temporarily and which contractor shall continue or whether work can be coordinated so that contractors may proceed simultaneously at no additional cost to the DISTRICT.
- (f) If the Project is split into phases and/or separate contracts, then CONTRACTOR has made allowances for any delays or damages which may arise from coordination with contractors for other phases or contracts. If any delays should arise from a contractor working on a different phase or contract, CONTRACTOR's sole remedy for damages, including delay damages, shall be against the contractor who caused such damage and not the DISTRICT. CONTRACTOR

00700  
GENERAL CONDITIONS for GENERAL  
CONTRACTOR  
CLOVIS UNIFIED SCHOOL DISTRICT

shall provide access to contractors for other phases or contracts as necessary to prevent delays and damages to contractors working on other phases or contracts.

**ARTICLE 12. OCCUPANCY**

- (a) DISTRICT reserves the right to occupy buildings and/or portions of the site at any time before completion, and such occupancy shall not constitute final acceptance of any part of Work covered by Contract Documents, nor shall such occupancy extend the date specified for completion of the Work. The warranty period for the Work will begin upon recording of the notice of completion.
- (b) The DISTRICT and the CONTRACTOR shall agree in writing to the responsibilities assigned to each of them for payments, security, maintenance, heat, utilities, damage to the Work, insurance, and the period for correction of the Work. Immediately prior to such partial occupancy or use, the DISTRICT, the CONTRACTOR, and the ARCHITECT shall jointly inspect the area to be occupied or portion of the Work to be used in order to determine and record the condition of the Work.

**ARTICLE 13. DISTRICT'S RIGHT TO TERMINATE AGREEMENT**

- (a) If the CONTRACTOR refuses or fails to complete the Work or any separable part thereof with such diligence as will insure its completion within the time specified or any permitted extension thereof, or fails to complete said Work within such time, or if the CONTRACTOR should file a petition for relief as a debtor, or should relief be ordered against CONTRACTOR as a debtor under Title 11 of the United States Code, or if CONTRACTOR should make a general assignment for the benefit of its creditors, or if a receiver should be appointed on account of its insolvency, or if it should refuse or should fail to supply enough properly skilled workers or proper materials to complete the Work in the time specified, or if CONTRACTOR should fail to make prompt payment to Subcontractors for materials or labor, or disregard laws or ordinances or instructions of DISTRICT, or if CONTRACTOR or its Subcontractors should otherwise violate any provision of the Contract Documents, then DISTRICT may, without prejudice to any other right or remedy, serve written notice upon CONTRACTOR and its surety of DISTRICT's intention to terminate the Contract. Such notice shall contain the reasons for such intention to terminate. Unless within **ten (10) days** after the service of such notice such condition shall cease or such violation shall cease and arrangements satisfactory to DISTRICT for the correction thereof have been made, the Contract shall cease and terminate. In such case, CONTRACTOR shall not be entitled to receive any further payment until the Work is finished to DISTRICT's satisfaction.
- (b) In the event of any such termination, DISTRICT shall immediately serve written notice thereof upon surety and CONTRACTOR, and surety shall have the right to take over and perform the Contract, provided, however, that if surety within **seven (7) days** after service upon it of notice of termination does not give DISTRICT written notice of its intention to take over and perform the Contract, or does not commence performance thereof within **fifteen (15) days** after service of the notice of termination by DISTRICT on surety, DISTRICT may take over the Work and prosecute it to completion by Agreement or by any other method it may deem advisable for the account and at the expense of CONTRACTOR, and CONTRACTOR and its surety shall be liable to DISTRICT for any excess cost or other damages occasioned by the DISTRICT thereby. Time is of the essence in the Contract. If the DISTRICT takes over the Work as hereinabove provided, the DISTRICT may, without liability for so doing, take possession of and utilize in completing the Work such materials, supplies, equipment and other property belonging to the CONTRACTOR as may be on the site of the Work and necessary therefore.

00700  
GENERAL CONDITIONS for GENERAL  
CONTRACTOR  
CLOVIS UNIFIED SCHOOL DISTRICT

- (c) If the expense of finishing the Work, including compensation for additional architectural, managerial, and administrative services, exceeds the unpaid balance of the Agreement, CONTRACTOR shall pay the difference to DISTRICT. Expense incurred by DISTRICT as herein provided, and damage incurred through CONTRACTOR's default, shall be certified to DISTRICT by ARCHITECT. If the unpaid balance under the Agreement shall exceed the expense of finishing the Work, including compensation for additional architectural, managerial, temporary service and administrative services, such excess shall be paid to CONTRACTOR.
- (d) In the event that sufficient funds are not appropriated to complete the Project or the DISTRICT determines that sufficient funds are not available to complete the Project, DISTRICT may terminate or suspend the completion of the Project at any time by giving written notice to the CONTRACTOR. In the event that the DISTRICT exercises this option, the DISTRICT shall pay for any and all work and materials completed or delivered onto the site, and the value of any and all work then in progress and orders actually placed which cannot be canceled up to the date of notice of termination. The value of work and materials paid for shall include a factor of 15% for the CONTRACTOR's overhead and profit and there shall be no other costs or expenses paid to CONTRACTOR. All work, materials, and orders paid for pursuant to this provision shall become the property of the DISTRICT.
- (e) DISTRICT may, without cause, order CONTRACTOR in writing to suspend, delay, or interrupt the Work in whole or in part for such period of time as DISTRICT may determine. Adjustment shall be made for increases in the cost of performance of the Contract caused by suspense, delay, or interruption.
- (f) The foregoing provisions are in addition to and not in limitation of any other rights or remedies available to the DISTRICT.

**ARTICLE 14. BONDS**

- (a) Unless otherwise specified in the Special Conditions and within ten (10) days of the Notice of Award of the Contract, CONTRACTOR shall furnish a surety bond in an amount equal to **one hundred percent (100%)** of the Contract Sum as security for faithful performance of the Contract Documents and shall furnish a separate bond in an amount equal to **one hundred percent (100%)** of the contract price as security for payment to persons performing labor and furnishing materials in connection with this Project. Bonds shall be in the form set forth in these Contract Documents. If CONTRACTOR fails to furnish the required bonds, DISTRICT may terminate the Contract for cause.
- (b) To the extent, if any, that the Contract Sum is increased in accordance with the Contract Documents, CONTRACTOR shall cause the amount of the performance and payments bonds to be increased accordingly and shall promptly deliver satisfactory evidence of such increase to DISTRICT. To the extent available, the bonds shall further provide that no change or alteration of the Contract Documents (including, without limitation, an increase in the Contract Sum, as referred to above), extensions of time, or modifications of the time, terms, or conditions of payment to CONTRACTOR will release the surety.
- (c) Only bonds executed by admitted surety insurers as defined in Code of Civil Procedure section 995.120 shall be accepted. The surety insurers must, unless otherwise agreed to by DISTRICT in writing, at the time of issuance of the bonds, have a rating not lower than "A-" as rated by A.M. Best Company, Inc., or other independent rating companies. DISTRICT reserves the right to approve or reject the surety insurers selected by CONTRACTOR and to require CONTRACTOR to obtain bonds from surety insurers satisfactory to OWNER.

00700  
GENERAL CONDITIONS for GENERAL  
CONTRACTOR  
CLOVIS UNIFIED SCHOOL DISTRICT

**ARTICLE 15. SUBSTITUTION OF SECURITIES**

- (a) Pursuant to the requirements of Public Contract Code section 22300, upon CONTRACTOR's request, DISTRICT will make payment to CONTRACTOR of any earned retention funds withheld from payments under the Contract Documents if CONTRACTOR deposits with the DISTRICT or in escrow with a California or federally chartered bank acceptable to DISTRICT, securities eligible for the investment pursuant to Government Code Section 16430 or bank or savings and loan certificates of deposit, upon the following conditions:
- (1) CONTRACTOR shall be the beneficial owner of any securities substituted for monies withheld and shall receive any interest thereon.
  - (2) All expenses relating to the substitution of securities under Section 22300 and under this Article, including, but not limited to DISTRICT's overhead and administrative expenses, and expenses of the escrow agent shall be the responsibility of the CONTRACTOR.
  - (3) If CONTRACTOR chooses to enter into an escrow agreement, such agreement shall be satisfactory to DISTRICT, which agreement shall be in the form provided as part of the Contract Documents and which shall allow for the conversion to cash to provide funds to meet defaults by the CONTRACTOR including, but not limited to, termination of the CONTRACTOR's control over the Work, stop notices filed pursuant to law, assessment of liquidated damages or amounts to be kept or retained under the provisions of the Contract Documents.
  - (4) Securities, if any, shall be returned to CONTRACTOR only upon satisfactory completion of the Project.
- (b) To minimize the expense caused by such substitution of securities, CONTRACTOR shall, prior to or at the time CONTRACTOR requests to substitute security, deposit sufficient security to cover the entire amount to be then withheld and to be withheld under the General Conditions of the Contract Documents. Should the value of such substituted security at any time fall below the amount for which it was substituted, or any other amount which the DISTRICT determines to withhold, CONTRACTOR shall immediately and at CONTRACTOR's expense deposit additional security qualifying under Section 22300 until the total security deposited is no less than equivalent to the amount subject to withholding under the Contract Documents.
- (c) In the alternative, under Section 22300, the CONTRACTOR may, prior to submittal of first Application for Payment, request DISTRICT to make payment of earned retentions directly to the escrow agent at the expense of the CONTRACTOR. Also at the CONTRACTOR's expense, the CONTRACTOR may direct investment of the payments into securities, and CONTRACTOR shall receive interest earned on such investment upon the same conditions as provided for securities deposited by CONTRACTOR. Upon satisfactory completion of the Project, CONTRACTOR shall receive from the escrow agent all securities, interest and payments received by the escrow agent from DISTRICT, pursuant to the terms of Section 22300. If CONTRACTOR elects to receive interest on moneys withheld in retention by DISTRICT, CONTRACTOR shall, at the request of any subcontractor, make that option available to the subcontractor regarding any monies withheld in retention by the CONTRACTOR from the subcontractor. If the CONTRACTOR elects to receive any interest on any monies withheld in retention by the Owner, then the subcontractor shall receive the identical rate of interest received by the CONTRACTOR on any retention monies withheld from the subcontractor by the CONTRACTOR, less any actual pro rata costs associated with administering and calculating that interest. In the event the interest rate is a fluctuating rate, the rate for the subcontractor shall be determined by calculating the interest rate paid during the time that retentions were

00700  
GENERAL CONDITIONS for GENERAL  
CONTRACTOR  
CLOVIS UNIFIED SCHOOL DISTRICT

withheld from the subcontractor. If the CONTRACTOR elects to substitute securities in lieu of retention, then, by mutual consent of the CONTRACTOR and subcontractor, the subcontractor may substitute securities in exchange for the release of monies held in retention by CONTRACTOR. This shall apply only to those subcontractors performing more than five percent (5%) of the CONTRACTOR'S total bid. The CONTRACTOR shall not require any subcontractor to waive any provision of this section.

- (d) If any provision of this Article shall be found to be illegal or unenforceable, then, notwithstanding, the remainder of this Article shall remain in full force and effect, and only such provision shall be deemed stricken.

**ARTICLE 16. LIABILITY, PROPERTY, BUILDER'S RISK AND OTHER INSURANCE REQUIREMENTS**

- (a) If this box  is checked, then (1) the DISTRICT's Owner-Controlled Insurance Program ("OCIP") applies to the Project and (2) attached as Exhibit "I" to these General Conditions is a description of OCIP and its insurance requirements, which apply in place of each of the following provisions of this Article 16, and all of Articles 17 and 18, unless otherwise provided in said Exhibit.
- (b) **Liability and Property Insurance.** Before the commencement of the Work, within ten (10) days of the Notice of Award of the Contract, and within limits acceptable to the DISTRICT, the CONTRACTOR shall purchase from and maintain such commercial general liability insurance per occurrence for bodily injury, personal injury and property damage as set forth in the Contract Documents and automobile liability insurance per accident for bodily injury and property damage combined single limit as set forth in the Contract Documents as will protect the CONTRACTOR from claims set forth below, which may arise out of or result from the CONTRACTOR's operations under the Contract and for which the CONTRACTOR may be legally liable, whether such operations are by the CONTRACTOR, by a Subcontractor, by Sub-subcontractor, by anyone directly or indirectly employed by any of them, or by anyone for whose acts any of them may be liable:
- (1) Claims for damages because of bodily injury (including emotional distress), sickness, disease, or death of any person other than the CONTRACTOR's employees. This coverage shall be provided in a form at least as broad as Insurance Services Office (ISO) Form CG 0001 11188;
  - (2) Claims for damages arising from personal or advertising injury in a form at least as broad as ISO Form CG 0001 11188;
  - (3) Claims for damages because of injury or destruction of tangible property, including loss of use resulting therefrom, arising from operations under the Contract Documents;
  - (4) Claims for damages because of bodily injury, death of a person, or property damage arising out of the ownership, maintenance, or use of a motor vehicle, all mobile equipment, and vehicles moving under their own power and engaged in the Work;
  - (5) Claims involving blanket contractual liability applicable to the CONTRACTOR's obligations under the Contract Documents, including liability assumed by and the indemnity and defense obligations of the CONTRACTOR and the Subcontractors; and
  - (6) Claims involving Operations/Premises and Completed Operations/Products, Independent Contractors' coverage, and Broad Form property damage, without any exclusions for collapse, explosion, demolition, underground coverage, and excavating. Coverage for completed operations must be at least as broad as CG 2010 11185.

00700  
GENERAL CONDITIONS for GENERAL  
CONTRACTOR  
CLOVIS UNIFIED SCHOOL DISTRICT

- (c) If commercial general liability insurance or another insurance form with a general aggregate limit is used, either the general aggregate limit shall apply separately to the project location (with the ISO CG 2501 or insurer's equivalent endorsement provided to the DISTRICT) or the general aggregate limit shall be twice the required occurrence limit.
- (d) Any deductible or self-insured retention must be declared to and approved by the DISTRICT. At the option of the DISTRICT, either the insurer shall reduce or eliminate such deductibles or self-insured retentions as respects the DISTRICT, its Board of Trustees, members of its Board of Trustees, officers, employees, agents and volunteers; or the CONTRACTOR shall procure a bond guaranteeing payment of losses and related investigations, claim administration and defense expenses.
- (e) **Subcontractor Insurance Requirements.** The CONTRACTOR shall require its subcontractors and any sub-subcontractors to take out and maintain similar public liability insurance and property damage insurance in like amounts.
- (f) **DISTRICT Insurance.** The DISTRICT shall be responsible for purchasing and maintaining its usual liability insurance or self-insurance. Optionally, the DISTRICT may purchase and maintain other insurance for self-protection against claims that may arise from operations under the Contract Documents.
- (g) **Additional Insured Endorsement Requirements.** The CONTRACTOR shall name, on any policy of insurance, the DISTRICT, the ARCHITECT, and their respective officers, employees and agents as additional insureds. Subcontractors shall name the CONTRACTOR, the DISTRICT, and the ARCHITECT, and their respective officers, employees and agents as additional insureds. The Additional Insured Endorsement included on all such insurance policies shall state that coverage is afforded the additional insured with respect to claims arising out of operations performed by or on behalf of the insured. If the additional insureds have other insurance, which is applicable to the loss, such other insurance shall be excess to any policy of insurance required herein. The amount of the insurer's liability shall not be reduced by the existence of such other insurance
- (h) **Consent of Insurer.** Partial occupancy or use in accordance with the Contract Documents shall not commence until the DISTRICT's insurance company providing property insurance has consented to such partial occupancy or use by endorsement or otherwise. The DISTRICT and the CONTRACTOR shall take reasonable steps to obtain consent of the insurance company and shall, without mutual consent, take no action with respect to partial occupancy or use that would cause cancellation, lapse, or reduction of the insurance.
- (i) **Other Insurance.** The CONTRACTOR shall provide all other insurance required to be maintained under applicable laws, ordinances, rules, and regulations.
- (j) **Compliance.** In the event of the failure of CONTRACTOR to furnish and maintain any insurance required by this Article, the CONTRACTOR shall be in default under the Contract. Compliance by CONTRACTOR with the requirement to carry insurance and furnish certificates, policies, Additional Insured Endorsement and Declarations Page evidencing the same shall not relieve the CONTRACTOR from liability assumed under any provision of the Contract Documents, including, without limitation, the obligation to defend and indemnify the DISTRICT and the ARCHITECT.
- (k) **Builder's Risk / "All Risk" Insurance/Course of Construction Insurance.** The DISTRICT has Builder's Risk / "All Risk" Insurance / Course of Construction Insurance on all insurable work included under the Contract Documents. The DISTRICT's Builder's Risk / "All Risk"

00700  
GENERAL CONDITIONS for GENERAL  
CONTRACTOR  
CLOVIS UNIFIED SCHOOL DISTRICT

Insurance / Course of Construction Insurance provides coverage for the DISTRICT only and not the CONTRACTOR or any other party.

**ARTICLE 17. PROOF OF CARRIAGE OF INSURANCE**

- (a) Subject to Article 16 above, CONTRACTOR shall not commence Work nor shall it allow any Subcontractor to commence work under the Contract Documents until all required insurance certificates, Additional Insured Endorsements, and Declarations Pages have been obtained and delivered in duplicate to and approved by DISTRICT. Such insurance shall be with an insurance company or companies lawfully authorized to do business in California as admitted insurers, with a minimum financial rating of A, Class XII status, as rated by the most current edition of Best's Key Rating Guide, published by A.M. Best Company.
- (b) Subject to Article 16 above, certificates and insurance policies shall include the following:
  - (1) A clause stating:

"This policy shall not be non-renewed, canceled, or reduced in required limits of liability or amounts of insurance until notice has been mailed to DISTRICT stating the date of cancellation or reduction. The date of cancellation or reduction may not be less than thirty (30) days after date of mailing notice."
  - (2) Language stating in particular those insured, extent of insurance, location, and operation to which insurance applies, expiration date, to whom cancellation and reduction notice will be sent, and length of notice period for cancellation and reduction of insurance.
  - (3) Language stating that the DISTRICT and ARCHITECT, and their respective officers, agents and employees are named additional insureds under the policy described and that such insurance policy shall be primary to any insurance or self-insurance maintained by the DISTRICT, and any other insurance carried by the DISTRICT with respect to the matters covered by such policy shall be excess and non-contributing.
- (c) Subject to Article 16 above, the CONTRACTOR and its Subcontractors shall produce a certified copy of any required insurance policy upon written request of the DISTRICT.
- (d) Subject to Article 16 above, in case of CONTRACTOR's failure or refusal to provide the required insurance, the DISTRICT may, at DISTRICT's option, take out and maintain, at the expense of the CONTRACTOR, such insurance in the name of CONTRACTOR or Subcontractor, as the DISTRICT may deem proper and may deduct the cost of taking out and maintaining such insurance from any sums which are due or to become due to the CONTRACTOR under the Contract Documents.

**ARTICLE 18. WORKERS' COMPENSATION INSURANCE**

- (a) Subject to Article 16 above, in accordance with the provisions of Section 3700 of the California Labor Code, the CONTRACTOR and every Subcontractor shall be required to secure the payment of compensation to its employees.
- (b) Subject to Article 16 above, the CONTRACTOR shall provide, during the term of the Contract, workers' compensation insurance for all of its employees engaged in work under the Contract Documents on or at the site of the Project, and, in case any of its Work is sublet, the CONTRACTOR shall require the Subcontractor similarly to provide workers' compensation insurance for all the latter's employees engaged in work under the subcontract. Any class of

00700  
GENERAL CONDITIONS for GENERAL  
CONTRACTOR  
CLOVIS UNIFIED SCHOOL DISTRICT

employee or employees not covered by a Subcontractor's insurance shall be covered by the CONTRACTOR's insurance. In case any class of employees engaged in Work under the Contract Documents on or at the site of the Project is not protected under the workers' compensation laws, the CONTRACTOR shall provide or shall cause a Subcontractor to provide, adequate insurance coverage for the protection of such employees not otherwise protected before the commencement of the Work. The CONTRACTOR shall file with the DISTRICT certificates of its insurance as required under this Article and in compliance with Labor Code section 3700. A **thirty (30) day** notice shall be provided to DISTRICT before the cancellation or reduction of any such insurance of CONTRACTOR or Subcontractor. CONTRACTOR shall submit proof of insurance and shall provide endorsements on the forms provided by the DISTRICT or on forms approved by the DISTRICT. Such endorsements shall be submitted concurrently with the Contract Documents and within ten (10) days of the Notice of Award of the Contract.

- (c) Subject to Article 16 above, prior to commencing Work, the CONTRACTOR shall sign and file with the DISTRICT the certificate required by the Labor Code section 1861, acknowledging the requirement to insure against liability for workers' compensation and promising to comply with this requirement before commencing Work under the contract and continuing to comply thereafter. The form of this certificate is included below.

*--- The remaining portion of this page has been left blank ---*



---

ARTICLE 18 (d) – Workers' Compensation Certificate

**WORKERS' COMPENSATION CERTIFICATE**

I am aware of the provisions of Labor Code section 3700, which require every employer to be insured against liability for workers' compensation or to undertake self-insurance in accordance with the provisions of that code, and I will comply with such provisions before commencing the performance of the Work of this contract and will continue to comply during performance.

\_\_\_\_\_

Date

\_\_\_\_\_

Name of Contractor

By: \_ Signature

\_\_\_\_\_

Print Name

\_\_\_\_\_

Title

(In accordance with Article 5 [commencing at Section 1860], Chapter 1, Part 7, Division 2 of the Labor Code, the above certificate must be signed and filed with the awarding body prior to performing any work under the contract.)

00700  
GENERAL CONDITIONS for GENERAL  
CONTRACTOR  
CLOVIS UNIFIED SCHOOL DISTRICT

- (e) Subject to Article 16 above, if the CONTRACTOR fails to maintain workers' compensation insurance, the DISTRICT may take out such insurance, and deduct and retain the amount of premium for such insurance from any sums due the CONTRACTOR.

ARTICLE 19. INTENTIONALLY LEFT BLANK

ARTICLE 20. DRAWINGS AND SPECIFICATIONS

- (a) Drawings and Specifications are intended to delineate and describe the Project and its component parts to such a degree as will enable a skilled and competent CONTRACTOR to intelligently bid upon the Work, coordinate the Work and to carry out the Work to a successful conclusion. If, as and to the extent that Public Contract Code section 1104 is deemed to apply after the Award of Contract, CONTRACTOR shall not be required to assume responsibility for the completeness and accuracy of architectural or engineering plans and specifications, notwithstanding any other provision in the Contract Documents, except to the extent that CONTRACTOR discovered or should have discovered and reported any errors and omissions to the ARCHITECT or DISTRICT as the result of any review of the plans and specifications by CONTRACTOR required by the Instructions to Bidders or other Contract Documents, whether or not actually performed by CONTRACTOR.
- (b) Drawings and Specifications are intended to comply with all laws, ordinances, rules and regulations of constituted authorities having jurisdiction, and where referred to in the Contract Documents, these laws, ordinances, rules, and regulations shall be considered as a part of the Contract within the limits specified. The CONTRACTOR shall bear all expenses of correcting work done contrary to applicable laws, ordinances, rules and regulations if the CONTRACTOR performed the work (1) without first consulting the ARCHITECT for further instructions regarding the work, or (2) disregarded the ARCHITECT's instructions regarding the work.
- (c) Questions regarding interpretation of drawings and specifications shall be clarified by the ARCHITECT; provided, however, that in the event ARCHITECT determines that CONTRACTORS requests for information (RFI's) are not justified or do not reflect adequate competent supervision, coordination, and / or knowledge by the CONTRACTOR or his/her Subcontractors, CONTRACTOR shall be required to pay ARCHITECT'S reasonable and customary fees in processing and responding to such requests. Should the CONTRACTOR commence Work or any part thereof without seeking clarification, and/or performing its own coordination obligations, the CONTRACTOR waives any claim for extra work or damages as a result of any ambiguity, conflict, or lack of information.
- (d) Figured dimensions on drawings shall govern, but work not dimensioned or mis-described shall be as directed. Work not particularly shown, mis-described, or specified shall be the same as similar parts that are shown or specified. Large scale drawings shall take precedence over smaller scale drawings as to shape and details of construction. Specifications shall govern as to materials, workmanship, and installation procedures. Drawings and specifications are intended to be fully cooperative and to agree. If through the process of Contract required coordination, CONTRACTOR observes that drawings and specifications are in conflict, CONTRACTOR shall promptly notify the ARCHITECT in writing, and any necessary changes shall be adjusted as provided in the Article entitled **Changes and Extra Work**; provided, however, that the specification calling for the higher quality material or workmanship shall prevail without additional cost to DISTRICT.
- (e) Materials or work described in words, which so applied, have a well known technical or trade meaning shall be deemed to refer to such recognized standards.

**00700**  
**GENERAL CONDITIONS for GENERAL**  
**CONTRACTOR**  
**CLOVIS UNIFIED SCHOOL DISTRICT**

- (f) It is not the intention of the Contract Documents to go into detailed descriptions of any materials and/or methods commonly known to the trade under "trade name" or "trade term." The mere mention or notation of such "trade name" or "trade term" shall be considered a sufficient notice to CONTRACTOR that it will be required to complete the work so named with all its incidental and accessory items according to the best practices of the trade.
- (g) The naming of any material and/or equipment shall mean furnishing and installing, including all incidental and accessory items thereto and/or labor necessary to achieve full and complete functioning of the material and/or equipment according to the best practices of the trade(s) involved, unless specifically noted otherwise.
- (h) One (1) full set of Contract Documents shall be provided to CONTRACTOR by the DISTRICT along with an electronic file (CD-ROM) of the complete set of the Contract Documents. If the CONTRACTOR requires more than the one (1) set of Contract Documents, CONTRACTOR shall print such drawings at no additional cost to the DISTRICT. It is the responsibility of the CONTRACTOR to note on the Contract Documents all addenda and clarifications to the Contract Documents that occurred prior to bid.
- (i) Electronic copies as provided for herein related to shop drawings, submittals, and close-out documents shall be in the following formats: All small document copies (8 1/2x11) shall be .pdf format, and all large document copies shall be in .tif format.

**ARTICLE 21. OWNERSHIP OF DRAWINGS**

- (a) All plans, drawings, designs, specifications, and other incidental Architectural and engineering work or materials and other Contract Documents and copies thereof furnished by DISTRICT are DISTRICT's property. They shall not be used in other work and shall be returned to DISTRICT on request at completion of Work, and may be used by DISTRICT as it may require, without any additional costs to DISTRICT. Electronic copies of the documents will not be provided except with expressed written consent of the DISTRICT and / or the ARCHITECT.

**ARTICLE 22. DETAIL DRAWINGS AND INSTRUCTIONS**

- (a) In case of ambiguity, conflict, or lack of information, ARCHITECT shall furnish additional instructions by means of drawings or otherwise, as necessary for proper execution of the Work. All such drawings and instructions shall be consistent with Contract Documents, true developments thereof, and reasonably inferable therefrom. Such additional instructions shall be furnished with reasonable promptness, provided that CONTRACTOR informs the ARCHITECT of the relationship of the request to the critical path of construction. Refer to the term, use, and protocol of an RFI defined in the Article entitled "Definitions".
- (b) Work shall be executed in conformity therewith and CONTRACTOR shall do no work without proper drawings and instructions.
- (c) The ARCHITECT will furnish necessary additional details to more fully explain the Work, which details shall be considered as part of the Contract Documents.
- (d) Should any details be more elaborate, in the opinion of the CONTRACTOR, than scale drawings and specifications warrant, CONTRACTOR shall give written notice thereof to the ARCHITECT within **twenty-one (21) days** of receipt. In case no notice is given to the ARCHITECT within **twenty-one (21) days**, it will be assumed the details are reasonable development of the scale drawings. In case notice is given, then it will be considered, and if found justified, the ARCHITECT will either modify the drawings or shall recommend to DISTRICT a change order for the extra work involved.

00700  
GENERAL CONDITIONS for GENERAL  
CONTRACTOR  
CLOVIS UNIFIED SCHOOL DISTRICT

- (e) All parts of the described and shown construction shall be of the best quality of their respective kinds and the CONTRACTOR is hereby advised to use all diligence to become fully involved as to the required construction and finish, and in no case to proceed with the different parts of the Work without obtaining first from the ARCHITECT such directions and/or drawings as may be necessary for the proper performance of the Work.

**ARTICLE 23. SHOP DRAWINGS**

- (a) Commensurate with the requirements of the Project schedule and within **forty-five (45) days** of the Notice to Proceed, the CONTRACTOR shall submit to ARCHITECT **four (4) hard** copies and one electronic copy, checked, coordinated and approved by CONTRACTOR, of all shop or setting list drawings, schedules, and materials list required for the work of various trades. If this project consists of any remodel / modernization work, field dimensions require verification prior to the preparation of the Shop Drawings. ARCHITECT shall review such drawings, schedules and materials list only for conformance with the design concept of Project and compliance with information given in Contract Documents, and return as approved or disapproved with guidance as to required corrections within **thirty (30) days**, unless more time is needed for the review. CONTRACTOR shall make any corrections required by ARCHITECT and submit **four (4)** final hard copies and one electronic copy of the shop drawing to ARCHITECT, and furnish such other copies as may be needed for construction within **fourteen (14) days** or as required by the Contract Schedule. ARCHITECT's approval of such drawings, schedules, or materials list shall not relieve CONTRACTOR from responsibility for deviations unless CONTRACTOR has in writing called ARCHITECT's attention to such deviations at time of submission and secured ARCHITECT's written approval, nor shall it relieve CONTRACTOR from responsibility for errors in shop drawings or schedules.
- (1) The ARCHITECT is entitled to additional review time to review complex and difficult submittals, including but not limited to structural steel shop drawings, mechanical equipment, electrical equipment, and special system components and parts. The CONTRACTOR shall breakout critical submittals into separate packages so as to expedite the review process of an individual item. The coordination of the overall submittal packages shall be the responsibility of the CONTRACTOR.
- (2) Shop Drawings requiring "**Deferred Approval**" require a substantial amount of time for agency review and approval. Deferred Approvals generally require re-submittal to the approving Plan Review Agency. The CONTRACTOR shall apply its skill and knowledge to expedite the Deferred Approval(s) from preparation to approval. The CONTRACTOR shall submit the shop drawings / submittals so as not to delay the Project schedule. Notwithstanding anything to the contrary herein, the CONTRACTOR shall make submittals of all Deferred Approvals to the ARCHITECT within **forty-five (45) days** of the Notice to Proceed. ARCHITECT shall review such Deferred Approval submittals, shall endeavor to obtain review by the Plan Review Agency, and shall return as approved or disapproved with guidance as to the required corrections within sixty (60) days, unless further time is needed under the circumstances. If resubmittals are required, ARCHITECT shall endeavor to review and return the resubmittal within sixty (60) days. CONTRACTOR shall allow sufficient time in its scheduling for corrections and resubmittals of Deferred Approval items in conformance with these requirements.
- (b) All submittals of shop drawings, catalog cuts, data sheets, schedules, and material lists shall be complete and shall conform to contract drawings and specifications. The CONTRACTOR shall prepare layout and coordination drawings to demonstrate the accuracy and fit of the materials and work.

**00700**  
**GENERAL CONDITIONS for GENERAL**  
**CONTRACTOR**  
**CLOVIS UNIFIED SCHOOL DISTRICT**

- (c) The term "shop drawing" as used herein shall be understood to include, but not be limited to, coordination efforts by CONTRACTOR, detail design calculations for the development of the shop drawing, fabrication and installation drawings, lists, graphs, and operating instructions.
- (d) Shop drawings shall be submitted at a time sufficiently early to allow review of same by the Plan Review Agency (if required), and the ARCHITECT, and to accommodate the rate of construction progress required under the Contract Documents. CONTRACTOR will be required to pay ARCHITECT's reasonable and customary fees in order to expedite review of shop drawings which are not submitted in a timely fashion. CONTRACTOR may be assessed \$100 a day for each day it is late in submitting a shop drawing or sample.
- (e) All shop drawing submittals shall be accompanied by an accurately completed transmittal form using the format found herein, or as approved by the DISTRICT. Any shop drawing submittal not accompanied by such a form, or where all applicable items on the form are not completed, will be returned for resubmittal. The CONTRACTOR may authorize a material or equipment supplier to deal directly with the ARCHITECT with regard to shop drawings. However, ultimate responsibility for the accuracy and completeness of the information contained in the submittal shall remain with the CONTRACTOR.
- (f) Normally, a separate transmittal form shall be used for each specific item, scheduled activity task, or class of material or equipment for which a submittal is required. However, due to the critical nature of a submittal, a submittal can be broken into separate sub-submittals in order to obtain the review of a more critical portion(s) of a submittal prior to the review of other sub-submittals. The transmittal form shall include the CPM Activity / Submittal /Task Number, Early Start (ES), Early Finish (EF), Late Finish (LF) and the float for the activity. Transmittal of shop drawings on various items using a single transmittal form will be permitted only when the items taken together constitute a manufacturer's "package" or are so functionally related that expediency indicates review of the group or package as a whole. At its option, the CONTRACTOR or Supplier may obtain from the ARCHITECT quantities of the shop drawing transmittal form at reproduction cost.
- (g) CONTRACTOR's review and approval of shop drawings and submittals shall include the following stamp:

"The CONTRACTOR has reviewed and approved not only the field dimensions but the construction criteria and has also made written notation regarding any information in the shop drawings or submittal that does not conform to the Contract Documents. This shop drawing or submittal has been coordinated with all other shop drawings and submittals received to date by CONTRACTOR, and this duty of coordination has not been delegated to the Owner's separate Contractors, Subcontractors, material suppliers, the ARCHITECT, or the engineers on this project.

\_\_\_\_\_  
Signature of CONTRACTOR"
- (h) Within **thirty (30) days** after receipt of shop drawings, the ARCHITECT will endeavor to return one or more prints of each drawing to CONTRACTOR with ARCHITECT's comments noted thereon. The CONTRACTOR shall make a complete and acceptable submittal to the ARCHITECT for the ARCHITECT's review by the second submission of drawings. The DISTRICT shall withhold funds due the CONTRACTOR to cover additional costs of the ARCHITECT's review beyond the second submission and any other costs incurred by DISTRICT.
- (i) If prints of the shop drawing are returned to the CONTRACTOR marked "**NO EXCEPTIONS TAKEN**," formal revision of said drawing will not be required. If prints of the drawing are

00700  
GENERAL CONDITIONS for GENERAL  
CONTRACTOR  
CLOVIS UNIFIED SCHOOL DISTRICT

returned to the CONTRACTOR marked "**MAKE CORRECTIONS NOTED**," formal resubmittal of said drawings will not be required. If prints of the drawing are returned to the CONTRACTOR marked "**REVISE AND RESUBMIT**," the CONTRACTOR shall revise said drawing and shall resubmit **four (4)** copies plus one (1) electronic copy of the revised drawing to the ARCHITECT. If prints of the drawing are returned to the CONTRACTOR marked "**REJECTED RESUBMIT**," the CONTRACTOR shall resubmit **four (4)** new copies plus one (1) electronic copy of the drawing to the ARCHITECT. Submittals being resubmitted for revisions or submitted due to previous rejection, the CONTRACTOR shall provide a written response indicating the nature of the correction(s) and/or cloud the revised item(s). All submittals returned "**rejected**" or "**revise and resubmit**" shall be copied and distributed as noted in section (a) of this Article.

- (j) Fabrication of an item shall not be commenced before the ARCHITECT has reviewed the pertinent shop drawings and returned copies to the CONTRACTOR marked with "NO EXCEPTIONS TAKEN," or "MAKE CORRECTIONS NOTED." Revisions indicated on shop drawings shall be considered as changes necessary to meet the requirements of the Contract Documents and shall not be taken as the basis of claims for extra work. The review of such drawings by the ARCHITECT will be limited to checking for general agreement with the Contract Documents, and shall in no way relieve the CONTRACTOR of responsibility for errors or omissions contained therein, nor shall such review operate to waive or modify any provision contained in the Project documents. Fabricating dimensions, quantities of material, applicable code requirements, and other contract requirements shall be the CONTRACTOR's responsibility. Coordinate integral and adjacent materials with other contracts prior to final shop drawings and fabrication.
- (k) No work represented by required shop drawings shall be purchased or commenced until the applicable submittal has been approved. The Work shall conform to the approved shop drawings and all other requirements of the Contract Documents. The CONTRACTOR shall not proceed with any related work which may be affected by the work covered under shop drawings until the applicable shop drawings have been approved, particularly where piping, machinery, and equipment and the required arrangements and clearances are involved.
- (l) Except where the preparation of a shop drawing is dependent upon the approval of a prior shop drawing, all shop drawings pertaining to the same class or portion of the Work shall be submitted simultaneously.
- (m) Calculations of a structural nature must be approved by the Plan Review Agency.
- (n) THE CONTRACTOR SHALL HAVE NO CLAIM FOR DAMAGES OR EXTENSION OF TIME DUE TO ANY DELAY RESULTING FROM THE CONTRACTOR HAVING TO MAKE THE REQUIRED REVISIONS TO SHOP DRAWINGS UNLESS REVIEW BY THE ARCHITECT IS DELAYED BEYOND THE TIME PROVIDED HEREIN AND THE CONTRACTOR CAN ESTABLISH THAT THE ARCHITECT'S DELAY IN REVIEW ACTUALLY RESULTED IN A DELAY IN THE CONTRACTOR CONSTRUCTION SCHEDULE. CONTRACTOR SHALL NOT BE ENTITLED TO ANY CLAIM FOR DAMAGES RESULTING FROM THE *PLAN REVIEW AGENCY* REVIEW. HOWEVER, DISTRICT MAY CONSIDER AN EXTENSION OF TIME DUE TO ANY DELAY CAUSED BY THE *PLAN REVIEW AGENCY* REVIEW.

**ARTICLE 24. SURVEY, LAYOUT AND FIELD ENGINEERING**

- (a) The CONTRACTOR performing the Work shall provide all layouts necessary to complete the Work. Layout shall include coordination drawings as well as the physical performance of the layout by the CONTRACTOR.

00700  
GENERAL CONDITIONS for GENERAL  
CONTRACTOR  
CLOVIS UNIFIED SCHOOL DISTRICT

- (b) Surveys to determine location of property lines and corners will be supplied by DISTRICT. Surveys to determine locations of construction, grading, site utilities and site work, shall be provided by the CONTRACTOR.
- (c) "Record Drawings" of site development shall be prepared by the CONTRACTOR, indicating revisions to the grading and the underground utility locations (horizontal and vertical locations) on the RECORD DRAWINGS provided by the CONTRACTOR as required to provide accurate as-built information. All other record drawing information including but not limited to building and hardscape shall be noted on the Contract Documents. The DISTRICT shall, at its option, confirm all grades and utility locations are accurate prior to final payment to the CONTRACTOR.

**ARTICLE 25. SOILS INVESTIGATION REPORT & CLAIMS FOR CONCEALED OR UNKNOWN CONDITIONS**

- (a) When a soils investigation report has been obtained from test holes at the site, such report is available for the CONTRACTOR's use in preparing its bid and Work under this Agreement. Any information obtained from such report or any information given on drawings as to surface and subsurface soil condition or to elevations of existing grades or elevations of underlying rock is approximate only. If, during the course of Work under this Agreement, CONTRACTOR encounters subsurface or latent conditions that differ materially from those indicated in the soils investigation report, then CONTRACTOR shall notify the DISTRICT immediately upon discovery of the condition.
- (b) If, during the course of Work under the Contract Documents, CONTRACTOR encounters subsurface or otherwise concealed physical conditions, that differ materially from those indicated in the Contract Documents, or unknown physical conditions of an unusual nature, which differ materially from those ordinarily found to exist and generally recognized as inherent in contract activities of the character provided for in the Contract Documents, then CONTRACTOR shall notify the DISTRICT of the discovery of the condition before the condition is materially changed, disturbed and/or covered. CONTRACTOR shall submit notice of possible claim for additional time and/or cost, no later than **three (3) days** after the first observance of the conditions.
- (c) WARNING: DISTRICT DOES NOT WARRANT THE SOILS AT THE PROJECT SITE. SOILS INVESTIGATION REPORT IS PROVIDED FOR CONTRACTOR'S INFORMATION ONLY. DISTRICT DOES NOT WARRANT THE SOILS CONDITIONS OF THE SITE AND CONTRACTOR IS FULLY RESPONSIBLE TO ASCERTAIN SITE CONDITIONS FOR THE PURPOSES OF DETERMINING CONSTRUCTION MEANS AND METHODS PRIOR TO COMMENCING CONSTRUCTION.

**ARTICLE 26. TESTS AND INSPECTIONS**

- (a) Tests and inspections will comply with California Code of Regulations Title 24, Part 1, Section 4-335.
- (b) If the Contract Documents, DISTRICT's instructions, laws, ordinances, or any public authority require any work to be specially tested or approved, CONTRACTOR shall give notice in accordance with such authority of its readiness for observation or inspection at least **two (2) working days** prior to being tested or covered up. If inspection is by authority other than DISTRICT, CONTRACTOR shall inform the DISTRICT's Inspector of the date fixed for such inspection. CONTRACTOR shall secure required certificates of inspection. Observations by DISTRICT's Inspector shall be promptly made, and where practicable, at source of supply. If any work should be covered up without approval or consent of DISTRICT's Inspector, it must be uncovered for examination and satisfactorily reconstructed at CONTRACTOR's expense in

**00700  
GENERAL CONDITIONS for GENERAL  
CONTRACTOR  
CLOVIS UNIFIED SCHOOL DISTRICT**

compliance with the Contract Documents. Costs of retests, and/or reinspections of any materials found to be not in compliance with the Contract Documents shall be paid for by the DISTRICT and deducted from the Contract. Other costs for tests and inspections shall be paid by the DISTRICT.

**ARTICLE 27. TRENCHES**

- (a) CONTRACTOR shall provide adequate sheeting, shoring, and bracing, or equivalent method, for the protection of life and limb in trenches and open excavation that conform to applicable safety standards.
- (b) If the Contract involves the excavation of any trench or trenches five feet or more in depth, the CONTRACTOR shall, in advance of excavation, submit to the DISTRICT or to whomever DISTRICT designates a detailed plan showing the design of shoring, bracing, sloping or other provisions to be made for worker protection from the hazard of caving ground during the excavation of such trench or trenches. If such plan varies from the Shoring System Standards established by the Construction Safety Orders of the Division of Industrial Safety, the plan shall be prepared by a registered civil or structural engineer employed by the CONTRACTOR, and all costs therefore shall be included in the price named in the Agreement for completion of the Work as set forth in the Contract Documents. In no case shall such plan be less effective than that required by the Construction Safety Orders. No excavation of such trench or trenches shall be commenced until said plan has been accepted by CAL-OSHA and a CAL-OSHA permit for such plan delivered to the DISTRICT. (Labor Code Section 6705; Health and Safety Code Section 17922.5.)
- (c) If the Contract Documents involve the digging of trenches or excavations that extend deeper than five (5) feet below the surface, the following shall apply:
  - (1) The CONTRACTOR shall promptly, and before the following conditions are disturbed, notify the DISTRICT, in writing, of any:
    - (A) Material that the CONTRACTOR believes may be hazardous waste, as defined in Section 25117 of the Health and Safety Code, which is required to be removed to a Class I, Class II, or Class III disposal site in accordance with provisions of existing law.
    - (B) Subsurface or latent physical conditions at the site different from those indicated by information about the site made available to bidders prior to the deadline for submitting bids.
    - (C) Unknown physical conditions at the site of any unusual nature, different materially from those ordinarily encountered and generally recognized as inherent in work of the character provided for in the Contract.
  - (2) The DISTRICT shall promptly investigate the conditions, and if it finds that the conditions do materially so differ, or do involve hazardous waste, and cause a decrease or increase in the CONTRACTOR's cost of, or the time required for, performance of any part of the Work shall issue a change order under the procedures described in the Contract Documents.
  - (3) In the event a dispute arises between the DISTRICT and the CONTRACTOR, whether the conditions materially differ or involve hazardous waste, or cause a decrease or increase in the CONTRACTOR's cost of, or time required for, performance of any part of the Work, the CONTRACTOR shall not be excused from any scheduled completion date



00700

**GENERAL CONDITIONS for GENERAL  
CONTRACTOR  
CLOVIS UNIFIED SCHOOL DISTRICT**

provided for by the Contract Documents, but shall proceed with all the Work to be performed under the Contract Documents. The CONTRACTOR shall retain any and all rights provided either by contract or by law which pertain to the resolution of disputes and protests between the contracting parties (Public Contract Code section 7104).

**ARTICLE 28. DOCUMENTS ON JOBSITE**

- (a) CONTRACTOR shall keep on the job site at all times one legible copy of all Contract Documents, including and annotated with addenda and change orders, and all approved drawings, plans, schedules and specifications. Said documents shall be kept in good order and available to ARCHITECT, ARCHITECT'S representatives, and all authorities having jurisdiction. CONTRACTOR shall be acquainted with and comply with the provisions of said regulations as they relate to this Project. (See particularly the duties of CONTRACTOR, 24 Cal. Code of Regulations Sec. 4-343.) CONTRACTOR shall also be acquainted with and comply with all California Code of Regulations provisions relating to conditions on this Project, particularly Titles 8 and 17.

**ARTICLE 29. STATE AUDIT**

- (a) Pursuant to and in accordance with the provisions of Government Code Section 8546.7, or any amendments thereto, all books, records and files of the DISTRICT, the CONTRACTOR, or any Subcontractor connected with the performance of the Contract Documents involving the expenditure of public funds in excess of Ten Thousand Dollars (\$10,000.00), including, but not limited to, the costs of administration of the Contract Documents, shall be subject to the examination and audit of the State Auditor at the request of the DISTRICT or as part of any audit of the DISTRICT for a period of **three (3) years** after final payment is made under the Agreement.

**ARTICLE 30. SUBSTITUTIONS**

- (a) CONTRACTOR shall follow all instructions and requirements set forth in **INSTRUCTIONS TO BIDDERS**, for compliance with this Article. All substitution requests related to structural items, fire safety issues, life safety issues and accessibility compliance issues shall be reviewed and approved by the Plan Review Agency.
- (b) Whenever in specifications any materials, process, service or equipment is indicated or specified by brand name, trade name, proprietary name or by name of manufacturer, such specification shall be deemed to be used for the purpose of facilitating description of material, process, service or equipment desired and shall be deemed to be followed by the words "or approved equal," and CONTRACTOR may, unless otherwise stated, offer any material, process, service, or equipment which shall be substantially equal or better in every respect to that so indicated or specified subject to DISTRICT or ARCHITECT approval.
- (c) All materials are mentioned as standards. Should a CONTRACTOR or bidder desire to substitute materials or methods for those specified, the CONTRACTOR or bidder shall follow the guidelines stated herein, and in accordance with the Contract Documents and Public Contract Code Section 3400. Each review of a substitution request by the ARCHITECT or its consultants may be billed to the CONTRACTOR or bidder at an hourly rate not to exceed \$150.00 per hour.
- (d) If material, process, service, or equipment offered by CONTRACTOR is not, in the opinion of ARCHITECT, or DISTRICT, equal or better in every respect to that specified, then CONTRACTOR shall furnish the material, process, service, or equipment specified. The burden

00700  
GENERAL CONDITIONS for GENERAL  
CONTRACTOR  
CLOVIS UNIFIED SCHOOL DISTRICT

of proof as to equality of any material, process, service, or equipment shall rest with CONTRACTOR. This provision authorizing submission of "or equal" substantiating data shall not in any way authorize an extension of time for performance of the Agreement.

Substitutions can be submitted in two ways:

- 1) Up to fourteen (14) working days prior to bid opening, or
  - 2) Up to thirty (30) working days after the Notice to Proceed has been issued for the Contract.
    - (1) Prior to Bid Opening: The CONTRACTOR or bidder must insure that proposed substitutions of materials by the CONTRACTOR or bidder are submitted to the ARCHITECT'S office a minimum of fourteen (14) working days prior to the bid opening for review and possible approval of any equipment or materials thought to be equal to or better than those specified in the drawings or specifications. An Addendum will be issued at a maximum of seven [7] working days and a minimum of three [3] working days prior to bid opening including all equipment and materials deemed equivalent to those specified and approved by Architect. Submittals will include comparative spec-data of that specified equipment or material and the proposed substitution as indicated on the completed "Substitution Request Form" in accordance with the Contract Documents. Submittals without this information will be automatically rejected.
    - (2) After Notice to Proceed: Submittals will include comparative spec-data of that specified equipment or material and the proposed substitution as indicated on the completed "Substitution Request Form" in accordance with the Contract Documents. Submittals without this information will be automatically rejected. Substitutions submitted after the thirty (30) day period will not be considered unless the product has been discontinued or the proposed working product will be of benefit to DISTRICT.
- (e) If, after the Contract has been awarded, the CONTRACTOR furnishes material, process, service, or equipment more expensive than that specified, any difference in cost of such material, process, service, or equipment so furnished shall be borne by CONTRACTOR. Any engineering, design fees, or approval agencies' fees required to make adjustments in material or work of all trades directly or indirectly affected by the approved substituted items shall be borne entirely by CONTRACTOR. Any difference in cost between an approved substitution that is lower in cost and the originally specified item shall be refunded by CONTRACTOR to DISTRICT.
- (f) Price, fitness and quality being equal with regard to supplies, the DISTRICT may prefer supplies grown, manufactured, or produced in California and next prefer supplies partially manufactured grown, or produced in California, provided the bids of said suppliers or the prices quoted by them do not exceed by more than 5% of the lowest bids/prices quoted by out of state suppliers, the major portion of the manufacture of the supplies is not done outside of California, and the public good will be served thereby. (Government Code section 4330-4334).
- (g) SUBMITTALS shall not be used as a means of requesting a substitution, the procedure for which is defined in this Article 30.

#### ARTICLE 31. SAMPLES

- (a) Consistent with the Contract Documents and within **thirty (30) working days** following the Notice to Proceed, CONTRACTOR shall furnish for approval, all samples as required in specifications together with catalogs and supporting data required by ARCHITECT. This provision shall not authorize any extension of time for performance of the Work. ARCHITECT

00700  
GENERAL CONDITIONS for GENERAL  
CONTRACTOR  
CLOVIS UNIFIED SCHOOL DISTRICT

shall review such samples as to conformance with design concept of work and for compliance with information given in the Contract Documents and shall approve or disapprove them within **fifteen (15) working days** from receipt.

- (b) Unless specified otherwise, sampling, preparation of samples and tests shall be in accordance with the latest standards of the American Society for Testing and Materials.
- (c) Samples shall, upon demand of ARCHITECT or DISTRICT, be submitted for tests or examinations, and considered before incorporation into the Work. CONTRACTOR shall be solely responsible for delays due to samples not being submitted in time to allow for tests. Acceptance or rejection will be expressed in writing. Work shall be equal to approved samples in every respect. Samples that are of value after testing will remain the property of the CONTRACTOR.

#### ARTICLE 32. CONSTRUCTION SCHEDULES

- (a) District shall notify bidders by Addendum prior to bid opening establishing the criteria for the Contractor prepared Construction Schedule. The criteria will determine the scheduling information required for the project being bid and the time allowed for submittal of the proposed schedule following award of the Contract.
  - (1) **PPS**: A Preliminary Project Schedule (PPS) within **twenty-one (21) days** after receiving the Notice to Proceed (NTP). The PPS shall include a detailed plan for the work to be completed in the first **ninety (90) days** of the Contract.
  - (2) **BPS**: A Baseline Project Schedule (BPS) within **sixty (60) days** after receiving the NTP. The BPS shall not show more than 10% of the total activities as critical, and no activity shall have a duration longer than **thirty (30) days**. The BPS shall indicate the beginning and completion dates of all phases of construction and shall use the "critical path method" (commonly called CPM) for the planning and scheduling, of all work required under the Project documents. The schedule will separately identify those milestones or events that must be completed before other portions of the Work can be accomplished. The BPS shall incorporate and schedule float for inclement weather and resulting muddy site conditions due to rain. Scheduled float for non-working rain related days and resulting muddy site conditions shall be based upon the latest and nearest available data from acceptable data issued from the National Weather Service.
  - (3) **MSU**: Monthly Schedule Updates (MSU) the updated schedule that accurately indicates the actual progress of the Work for the prior month, and the remaining planned completion of the Work.
  - (4) **SIS**: Short Interval Schedules (SIS) shall be provided at regularly scheduled meetings, and include the Construction Schedule activity numbers. The SIS shall be a **three (3) week** schedule, based upon the most recent MSU. The SIS shall include a **one (1) week** look-back, the current weeks work, and **one (1) week** thereafter. The information on the SIS shall be of sufficient detail to evaluate inspection requests.
- (b) The scheduling is necessary for the DISTRICT'S adequate monitoring of the progress of the Work and it is to be used in the preparation of the Progress Payment Applications. The DISTRICT may disapprove such a schedule and require modification to it if, in the opinion of the ARCHITECT or DISTRICT, adherence to the progress schedule will cause the Work not to be completed in accordance with the **Agreement**. CONTRACTOR shall adhere to any such modifications required by the DISTRICT. Between the Monthly Schedule Updates (MSU's), it is the obligation of the CONTRACTOR to monitor the progress of the Work against the current

00700

**GENERAL CONDITIONS for GENERAL  
CONTRACTOR  
CLOVIS UNIFIED SCHOOL DISTRICT**

MSU Construction Schedule activities, and to notify the Architect and OWNER in writing of all changed activity start dates and finish dates.

- (c) CONTRACTOR will exchange scheduling information with Subcontractors and suppliers. CONTRACTOR will order work, equipment, and materials with sufficient lead time to avoid interruption of the Work.
- (d) The CONTRACTOR shall also, if requested by the ARCHITECT or DISTRICT, provide revised schedules within **fifteen (15) days** if, at any time, the ARCHITECT or DISTRICT considers the completion date to be in jeopardy. The revised schedule shall be designed to show how the CONTRACTOR intends to accomplish the Work to meet the original completion date. The form and method employed by the CONTRACTOR shall be the same as for the original progress schedule. The CONTRACTOR shall modify any portions of the schedule that become infeasible because of "activities behind schedule" or for any other valid reason. CONTRACTOR will provide documents and justification for any schedule changes. An activity that cannot be completed by its original completion date shall be deemed to be behind schedule.
- (e) IF CONTRACTOR SUBMITS A REVISED SCHEDULE SHOWING AN EARLIER COMPLETION DATE FOR THE PROJECT, DISTRICT'S ACCEPTANCE OF THIS REVISED SCHEDULE SHALL NOT ENTITLE CONTRACTOR TO ANY DELAY CLAIM OR DAMAGES DUE TO ANY SUCH REVISED SCHEDULE.
- (f) In connection with the DSA Construction Oversight Process, which includes the use of inspection cards and review of changes to the DSA-approved construction documents, the CONTRACTOR must include specific tasks in its baseline schedule to take into account these procedures since they are critical path issues.

**ARTICLE 33. MATERIALS AND WORK**

- (a) Except as otherwise specifically stated in this Agreement, CONTRACTOR shall provide and pay for all materials, supplies, tools, equipment, labor, transportation, superintendence, temporary constructions of every nature, and all other services and facilities of every nature whatsoever necessary to execute and complete the Project within the specified time.
- (b) Unless otherwise specified, all materials shall be new and the best of their respective kinds and grades as noted or specified, and workmanship shall be of good quality.
- (c) Materials shall be furnished in ample quantities and at such times as to insure uninterrupted progress of Work and shall be stored properly and protected as required.
- (d) CONTRACTOR shall, after issuance of the Notice to Proceed by DISTRICT, place orders for materials and/or equipment as specified so that delivery may be made without delays to the Work. CONTRACTOR shall, upon demand by the ARCHITECT, furnish to the ARCHITECT documentary evidence showing that orders have been placed.
- (e) DISTRICT reserves the right, due to any neglect in not complying with the above instructions, to place orders for such materials and/or equipment as it may deem advisable in order that the Work may be completed by the date specified in the Agreement, and all expenses incidental to the procuring of these materials and/or equipment shall be paid for by the CONTRACTOR.
- (f) No materials, supplies, or equipment for Work under the Contract Documents shall be purchased subject to any chattel mortgage or under a conditional sale or other agreement by which an interest therein or in any part thereof is retained by the seller or supplier. CONTRACTOR warrants good title to all material, supplies, and equipment installed or

00700  
GENERAL CONDITIONS for GENERAL  
CONTRACTOR  
CLOVIS UNIFIED SCHOOL DISTRICT

incorporated in the Work and agrees upon completion of all Work to deliver the premises, together with all improvements and appurtenances constructed or placed thereon by it, to DISTRICT free from any claims, liens, or charges. CONTRACTOR further agrees that neither it nor any person, firm, or corporation furnishing any materials or labor for any work covered by the Contract Documents shall have any right to any lien upon the premises or any improvement or appurtenance thereon, except that CONTRACTOR may install metering devices or other equipment of utility companies or of political subdivisions, title to which is commonly retained by the utility company or political subdivision. In the event of installation of any such metering device or equipment, CONTRACTOR shall advise DISTRICT as to the owner thereof.

- (g) Nothing contained in this Article, however, shall defeat or impair the rights of persons furnishing material or labor under any bond given by CONTRACTOR for their protection or any rights under any law permitting such persons to look to funds due CONTRACTOR in the hand of DISTRICT, and this provision shall be inserted in all subcontracts and material contracts and notice of its provisions shall be given to all persons furnishing materials or labor when no formal contract is entered into for such materials or labor.
- (h) Materials and/or equipment and the attendant liability for its protection and safety shall remain in the CONTRACTOR until incorporated in the Work and accepted by the DISTRICT; no part of the materials and/or equipment shall be removed from its place of storage except for immediate installation in the Work; and CONTRACTOR shall keep an accurate inventory of all materials and/or equipment in a manner satisfactory to the DISTRICT or its authorized representative. Refer to the Article entitled SCHEDULE OF VALUES AND PROGRESS PAYMENT APPLICATIONS for material title.

**ARTICLE 34. INTEGRATION OF WORK**

- (a) CONTRACTOR shall do all cutting, fitting, patching, and preparation of work as required to make its several parts come together properly, and fit it to receive or be received by work of other contractors; including both the CONTRACTOR's and DISTRICT's forces. In the event of clarifications, the CONTRACTOR shall follow all Supplemental Instructions (SI's) given by the ARCHITECT.
- (b) All costs caused by defective or ill-timed work shall be borne by CONTRACTOR.
- (c) CONTRACTOR shall not endanger any work by cutting, excavating, or otherwise altering work and shall not cut or alter work of any other CONTRACTOR without the written consent of the ARCHITECT. CONTRACTOR shall be solely responsible for protecting existing work on adjacent properties and shall obtain all required permits for shoring and excavations near property lines.
- (d) When modifying existing work or installing new work adjacent to existing work, CONTRACTOR shall match, as closely as conditions of the site and materials will allow, the finishes, textures, and colors of the original work, refinishing new work as required to match existing work at no additional cost to DISTRICT.

**ARTICLE 35. OBTAINING OF PERMITS, LICENSES AND EASEMENTS**

- (a) Permits, licenses, and certificates necessary for prosecution of Work, shall be secured and paid for by CONTRACTOR, unless otherwise specified. All such permits, licenses, and certificates shall be delivered to the ARCHITECT before they are required for the Work to be performed or demand is made for the certificate of final payment, whichever comes first. CONTRACTOR shall, and shall require Subcontractors to, maintain CONTRACTOR's licenses in effect as required by law.

00700  
GENERAL CONDITIONS for GENERAL  
CONTRACTOR  
CLOVIS UNIFIED SCHOOL DISTRICT

- (b) Easements for permanent structures or permanent changes in existing facilities shall be secured and paid for by DISTRICT, unless otherwise specified.
- (c) Permits and charges for utility services by serving utilities shall be secured and paid for by DISTRICT, including development and capitol facility fees, Electrical and Gas Rule 16 and/or Rule 20 fees, Cable and Telephone fees.
- (d) If applicable, the DISTRICT shall file a Notice of Intent to comply with the terms of the general permit to discharge storm water associated with construction activity (WQ Order No. 920-08-DWQ). The Notice of Intent must be sent to the following address along with the appropriate payment: California State Water Resources Control Board, Division of Water Quality, Storm Water Permit Unit, P.O. Box 100, Sacramento, CA 95812-0100. The CONTRACTOR may also call the State Water Board's Construction Activity Storm Water Hotline at (916) 341-5272. The Notice of Intent shall be filed prior to the start of any construction activity.

**ARTICLE 36. INTENTIONALLY LEFT BLANK**

**ARTICLE 37. EXISTING UTILITY LINES; REMOVAL, RESTORATION**

- (a) Pursuant to Government Code Section 4215, the DISTRICT assumes the responsibility for removal, relocation, and protection of utilities located on the construction site at the time of commencement of construction –that are not identified in the Contract Documents . The CONTRACTOR shall be compensated for the costs of locating, repairing damage not due to the failure of the CONTRACTOR to exercise reasonable care, and removing or relocating existing main or trunkline utility facilities not indicated in the Contract Documents with reasonable accuracy, and for equipment on the Project necessarily idled during such work... The CONTRACTOR shall not be assessed for liquidated damages for delay in completion of the - work caused by failure of the DISTRICT to provide for removal or relocation of –existing main or trunkline utility facilities. -
- (b) The CONTRACTOR shall be responsible for removal, relocation, and protection of (1) existing main or trunkline utilities located on the construction site at the time of commencement of construction that are identified in the Contract Documents and (2) all utilities, other than existing main or trunkline utilities, located on the construction site at the time of commencement of construction.
- (c) This Article shall not be construed to preclude assessment against the CONTRACTOR for any other delays in completion of the Work. Nothing in this Article shall be deemed to require the DISTRICT to indicate the presence of existing service laterals or appurtenances whenever the presence of such utilities on the construction site can be inferred from the presence of other visible facilities, such as buildings, meter junction boxes, on or adjacent to the site of the construction.
- (d) As part of the Work to be performed, CONTRACTOR shall provide the notices and proceed in accordance with Government Code Sections 4216.2, 4216.3 and 4216.4 (available at <http://www.Digalert.com>), and shall pay all fees charged pursuant to Government Code Section 4216, et seq.
- (e) Prior to any underground excavation and/or trenching (example: disturbance of the site of any kind, demolition of any form, trenching, digging, removing of concrete, or scraping of grass, etc.) within the CONTRACTOR's scope of Work, the CONTRACTOR shall (1) visit the construction site, examine the building(s), if any, and any work that may have been done thereon, and assess the presence of visible facilities, on or adjacent to the construction site that would

00700  
GENERAL CONDITIONS for GENERAL  
CONTRACTOR  
CLOVIS UNIFIED SCHOOL DISTRICT

indicate the presence of underground utilities on the construction site; (2) review the plans and specifications, all applicable "as built" documents, and all other applicable Contract Documents, to ascertain the existence and location of underground utilities not identified in the Contract Documents; and (3) perform pothole testing as necessary to ascertain the existence and location of underground utilities not identified in the Contract Documents.

- (f) If the CONTRACTOR at any time discovers utility facilities not identified in the Contract Documents, or any errors or omissions in the plans and specifications, "as built" documents, or other contract Documents, the CONTRACTOR shall immediately notify the DISTRICT in writing.
- (g) Should the CONTRACTOR damage a utility service, CONTRACTOR shall provide both the DISTRICT and the ARCHITECT with notice. The DISTRICT shall have the authority to repair the damaged service, or the DISTRICT and/or ARCHITECT can direct CONTRACTOR to repair the damaged service. In the event CONTRACTOR damages a service(s) that is not the DISTRICT's responsibility to remove, relocate, and protect pursuant to subsection (a), or the CONTRACTOR does not take reasonable care as described in subsection (e), CONTRACTOR shall repair service at no cost to the DISTRICT, CONTRACTOR is required to schedule, notify and coordinate with "U.S.A. Locates" for the location(s) of all off-site services and or service connections.-
- (h) The DISTRICT will provide the CONTRACTOR the "DISTRICT's -"Locate Utilities Request Form to ensure successful scheduling and documentation of requests for locating of underground utilities to prevent damage to DISTRICT utilities and property during the construction process. Failure to comply by the CONTRACTOR which results in damage to DISTRICT's utilities and property shall obligate CONTRACTOR to make necessary repairs to damaged utilities and/or property at no cost to the DISTRICT.

**ARTICLE 38. WORK TO COMPLY WITH APPLICABLE LAWS AND REGULATIONS**

- (a) CONTRACTOR shall give all notices and comply with all laws, ordinances, rules, and regulations applicable to the Work as indicated and specified. All Work shall be performed in conformance with all applicable laws, ordinances, rules, and regulations, including, but not limited to California Code of Regulations, Title 24, Parts 1 through 5, Part 7, Part 9, and Title 19.
- (b) If CONTRACTOR observes that plans, drawings or specifications are at variance with any applicable law, ordinance, rule, or regulation, CONTRACTOR shall promptly notify ARCHITECT in writing and any changes deemed necessary by the ARCHITECT shall be adjusted as provided for at **ARTICLE 59, CHANGES AND EXTRA WORK**. If CONTRACTOR performs any Work which it knew, or through exercise of reasonable care should have known, to be contrary to such laws, ordinances, rules or regulations, and without such notice to ARCHITECT, CONTRACTOR shall bear all costs arising therefrom. Where plans, drawings or specifications state that materials, processes, or procedures must be approved by the Plan Review Agency, State Fire Marshal (SFM), or other body or agency, CONTRACTOR shall be responsible for satisfying the requirements of such bodies or agencies.

**ARTICLE 39. ACCESS TO WORK**

- (a) DISTRICT and its representatives shall at all times have access to the Work wherever it is in preparation or progress. CONTRACTOR shall provide safe and proper facilities for such access so that DISTRICT's representatives may perform their functions.

00700  
GENERAL CONDITIONS for GENERAL  
CONTRACTOR  
CLOVIS UNIFIED SCHOOL DISTRICT

**ARTICLE 40. TIMELY PAYMENTS BY CONTRACTOR**

- (a) CONTRACTOR shall pay to each of its subcontractors, not later than the 10th day following each payment to CONTRACTOR by DISTRICT the respective amounts allowed CONTRACTOR on account of work performed by the respective subcontractor's to the extent of such subcontractor's interest therein.

**ARTICLE 41. INTENTIONALLY LEFT BLANK**

**ARTICLE 42. INTENTIONALLY LEFT BLANK**

**ARTICLE 43. INTENTIONALLY LEFT BLANK**

**ARTICLE 44. CLEANING UP**

- (a) CONTRACTOR shall at all times keep Work site free from CONTRACTOR generated debris such as waste, rubbish, and excess materials and equipment caused by this work, at the least on a daily basis. CONTRACTOR shall not leave debris under, in, or about the Work site. Upon completion of CONTRACTOR's Work, CONTRACTOR shall clean all interior and exterior materials installed by CONTRACTOR, and any areas and surfaces where debris and/or overspray has collected as a direct or indirect result of the CONTRACTOR's Work. If the project consists of any street improvements (paving / gutter and/or sidewalk surfaces), drain inlets and any pipeline facilities, such work shall also be free of any debris and sediments. CONTRACTOR shall be responsible for removing all hazardous waste from the job-site in containers provided by CONTRACTOR.
- (b) CONTRACTOR will provide dumpsters for the collecting and disposal of non-hazardous CONTRACTOR-generated waste from the Work EXCEPT as noted in the Contract Documents. CONTRACTOR shall be responsible for placing waste into such dumpsters. If CONTRACTOR fails to clean up, the DISTRICT shall do so and all of the costs thereof shall be charged to the CONTRACTOR.
- (c) The DISTRICT shall provide final cleaning after the CONTRACTOR's clean up has been completed and if not satisfactory to the DISTRICT, CONTRACTOR will be billed any cost incurred by the DISTRICT. CONTRACTOR's final cleaning shall include all clean-up as described in the summary of work.

**ARTICLE 45. PATENTS, ROYALTIES, AND INDEMNITIES**

- (a) The CONTRACTOR shall hold and save the DISTRICT and its governing board, officers, agents, and employees harmless from liability of any nature or kind, including cost and expense, for or on account of any patented or unpatented invention, process, article, or appliance manufactured or used in the performance of the Contract, including its use by the DISTRICT, unless otherwise specifically provided in the Contract Documents, to the extent such liability arises from the negligence or willful misconduct of the CONTRACTOR.

**ARTICLE 46. GUARANTEE**

- (a) CONTRACTOR warrants that the Work (which includes any equipment furnished by CONTRACTOR as part of the materials) shall:
  - (1) Be free from defects in workmanship and material; Be free from defects in any design performed by CONTRACTOR;



00700  
GENERAL CONDITIONS for GENERAL  
CONTRACTOR  
CLOVIS UNIFIED SCHOOL DISTRICT

- (2) Be new, and conform and perform to the requirements stated in the specifications and where detail requirements are not so stated, shall conform to applicable industry standards; and
  - (3) Be suitable for the use stated in the specifications.
- (b) The warranty period for discovery of defective Work shall commence on the date stamped on the Notice of Completion verifying County recordation and continue for the period set forth in the specifications or for one year if not so specified. If, during the warranty period, the Work is not available for use due to defective Work, such time of unavailability shall not be counted as part of the warranty period. The warranty period for corrected defective Work shall continue for a duration equivalent to the original warranty period.
- (c) DISTRICT shall give CONTRACTOR prompt written notice after discovery of any defective Work. CONTRACTOR shall correct any such defective Work, as well as any damage to any other part of the Work resulting from such defective Work, and shall provide repair, replacement, or reimbursement, at its sole expense, in a manner approved by the DISTRICT and with due diligence and dispatch as required to make the Work ready for use (without impact to the DISTRICT's operations) by DISTRICT, ordinary wear and tear, unusual abuse or neglect excepted. Such corrections shall include, but not be limited to, any necessary adjustments, modifications, changes of design (unless of DISTRICT's design), removal, repair, replacement or reinstallation, and shall include all necessary parts, materials, tools, equipment, transportation charges and labor as may be necessary, and cost of removal and replacement of Work shall be performed at a time and in such a manner so as to minimize the disruption to DISTRICT's use of the Work.
- (d) In the event of failure of CONTRACTOR or Surety to commence and pursue with diligence any such repairs or replacements within **five (5) days** after being notified in writing, DISTRICT is hereby authorized to proceed to have defects repaired or replaced and made good at the expense of the CONTRACTOR and the Surety who hereby agree to pay any costs and charges therefore immediately on demand.
- (e) If, in the opinion of the DISTRICT, defective Work creates a dangerous condition or requires immediate correction or attention to prevent further loss to the DISTRICT or to prevent interruption of operations of the DISTRICT, the DISTRICT will attempt to give the written notice required by this Article. If the CONTRACTOR or Surety cannot be contacted or neither complies with the DISTRICT's requirements for correction within a reasonable time as determined by the DISTRICT, the DISTRICT may, notwithstanding the provisions of this Article, proceed to make such correction or provide such attention and the costs of such correction or attention shall be charged against the CONTRACTOR and Surety. Such action by the DISTRICT will not relieve the CONTRACTOR and Surety of the guarantees provided in this Article or elsewhere in the Contract Documents.
- (f) This Article does not in any way limit the guarantees on any items for which a longer guarantee is specified or on any items for which a manufacturer gives a guarantee for a longer period. CONTRACTOR shall furnish to DISTRICT two (2) hard copies plus 3 electronic copies on compact disc, and all appropriate guarantee or warranty certificates upon completion of the Project or upon request by DISTRICT.
- (g) All guarantees required under this Article shall be in writing on the Guarantee form included in the Contract Documents or as furnished by the DISTRICT.
- (h) CONTRACTOR shall provide to DISTRICT two (2) hard copies plus 3 electronic copies of instruction and maintenance manuals for all items that require same.

00700  
GENERAL CONDITIONS for GENERAL  
CONTRACTOR  
CLOVIS UNIFIED SCHOOL DISTRICT

- (i) The rights and remedies outlined in this Article are in addition to all others available to the DISTRICT.

**ARTICLE 47. DUTY TO PROVIDE COMPETENT WORKERS**

- (a) CONTRACTOR and Subcontractors shall at all times enforce strict discipline and good order among their employees and shall not employ on the Work any person not skilled or competent in the work assigned to such person. It shall be the responsibility of CONTRACTOR to ensure compliance with this Article.
- (b) Any person in the employ of the CONTRACTOR or Subcontractors whom DISTRICT or ARCHITECT may deem incompetent, unfit, troublesome or otherwise undesirable shall be excluded from the Work site and shall not again be employed on it except with the written consent of DISTRICT.

**ARTICLE 48. EMPLOYMENT OF LABOR/PREVAILING WAGE RATES**

- (a) The Project is a public work, the Work shall be performed as a public work and pursuant to California Labor Code Section 1770 et seq., the Director of Industrial Relations has determined the general prevailing rate of per diem wages and the general prevailing rate for holiday and overtime work in the locality in which the Work is to be performed, for each craft, classification or type of worker needed for the Project. Per diem wages shall be deemed to include employer payments for health and welfare, pension, vacation, apprenticeship or other training programs, and similar purposes. Copies of the rates are on file at DISTRICT's principal office. The rate of prevailing wage for any craft, classification or type of workmanship to be employed on this Project is the rate established by the applicable collective bargaining agreement which rate so provided is adopted by this reference and shall be effective for the life of this Contract or until the Director of the Department of Industrial Relations determines that another rate be adopted. It shall be mandatory upon the CONTRACTOR and on any Subcontractor to pay not less than the said specified rates to all workers employed in the execution of this Agreement.
- (b) The CONTRACTOR and any Subcontractor under the CONTRACTOR as a penalty to DISTRICT shall forfeit not more than Fifty Dollars (\$50.00) for each calendar day or portion thereof for each worker paid less than the stipulated prevailing rates for such work or craft in which such worker is employed. The difference between such stipulated prevailing wage rates and the amount paid to each worker for each calendar day or portion of a calendar day for which each worker was paid less than the stipulated prevailing wage rate shall be paid to each worker by the CONTRACTOR or Subcontractor.
- (c) Nothing contained herein shall be deemed to supersede any applicable laws, orders, or regulations issued by competent authority governing wages, hours of work of the employment of labor, nor to condone any violation of such laws, orders, or regulations.
- (d) DISTRICT shall post at appropriate conspicuous weatherproof points on the site of the Project a schedule showing the Prevailing Wage Determinations published by the Director of the California Department of Industrial Relations, which are applicable to the Project.
- (e) The CONTRACTOR and each Subcontractor shall keep or cause to be kept an accurate record for work on this Project showing the names, addresses, social security numbers, work classification, straight time and overtime hours worked and occupations of all laborers, workers and mechanics employed by them in connection with the performance of the Contract or any subcontract, and showing also the actual per diem wage paid to each of such workers, which records shall be open at all reasonable hours to inspection by DISTRICT, its officers and agents and to the representatives of the Division of Labor Law Enforcement of the State Department of

00700  
GENERAL CONDITIONS for GENERAL  
CONTRACTOR  
CLOVIS UNIFIED SCHOOL DISTRICT

Industrial Relations. CONTRACTOR and each Subcontractor shall comply with Labor Code section 1776. The CONTRACTOR and each subcontractor shall furnish a certified copy of all payroll records directly to the Labor Commissioner monthly or more frequently, if so specified in the Contract and in a format the Labor Commissioner prescribes.

- (f) For public works contracts awarded on and after January 1, 2015, those public works projects shall be subject to compliance monitoring and enforcement by the Department of Industrial Relations.
- (g) The CONTRACTOR shall be responsible for ensuring that the labor standards provisions are followed by its Subcontractors, and shall be responsible for the Labor Code violations of its Subcontractors.
- (h) It is the policy of the DISTRICT to strictly enforce the public works prevailing wage requirements set for in the California Labor Code. To that end, the CONTRACTOR and Subcontractors found to be repeat violators of the Labor Code are subject to debarment from bidding on, or being awarded, any public works construction contract to the extent provided by law.
- (i) As of March 1, 2015, the CONTRACTOR and any proposed Subcontractors shall not be qualified to submit a bid or to be listed in a bid or GMP proposal for the Project unless currently registered and qualified under California Labor Code section 1725.5 to perform public work as defined by Division 2, Part 7, Chapter 1 (§§1720 et seq.) of the Labor Code.
- (j) As of April 1, 2015, the CONTRACTOR and any proposed Subcontractors shall not be qualified to enter into, or engage in the performance of, the Contract unless currently registered and qualified under Labor Code section 1725.5 to perform public work.

**ARTICLE 49. HOURS OF WORK**

- (a) As provided in Article 3 (commencing at Section 1810), Chapter 1, Part 7, Division 2 of the Labor Code, eight (8) hours of labor shall constitute a legal day's work. The time of service of any worker employed at any time by the CONTRACTOR or by any Subcontractor on any subcontract under the Contract upon the Work or upon any part of the Work contemplated by the Contract shall be limited and restricted by the Contract to eight (8) hours per day, and forty (40) hours during any one week, except as hereinafter provided. Notwithstanding the provisions hereinabove set forth, work performed by employees of CONTRACTOR in excess of eight (8) hours per day and forty (40) hours during any one week, shall be permitted upon this public work upon compensation for all hours worked in excess of eight (8) hours per day at not less than one and one-half times the basic rate of pay.
- (b) The CONTRACTOR shall keep and shall cause each Subcontractor to keep an accurate record showing the name of and actual hours worked each calendar day and each calendar week by each worker employed by CONTRACTOR in connection with the Work or any part of the Work contemplated by the Contract Documents. The record shall be kept open at all reasonable hours to the inspection of the DISTRICT and to the Division of Labor Standards Enforcement, Department of Industrial Relations. Daily reports shall be transmitted to the ARCHITECT/DISTRICT using the form provided in the Specification Section entitled "**FORMS AND REPORTS**" or on a form provided by the DISTRICT.
- (c) Pursuant to Labor Code Section 1813, the CONTRACTOR or subcontractor shall pay to the DISTRICT a penalty of twenty-five Dollars (\$25) for each worker employed in the execution of this Contract by the CONTRACTOR or by any Subcontractor for each calendar day during which such worker is required or permitted to work more than eight (8) hours in any one

**00700**  
**GENERAL CONDITIONS for GENERAL**  
**CONTRACTOR**  
**CLOVIS UNIFIED SCHOOL DISTRICT**

calendar day and 40 hours in any one calendar week in violation of the provisions of Article 3 (commencing at Section 1810), Chapter 1, Part 7, Division 2 of the Labor Code. Regular work hours are deemed to be 7:00 a.m. to 3:30 p.m. Monday through Friday excluding holidays.

- (d) Any work performed after regular working hours, or on Saturdays, Sundays or other holidays shall be performed without additional expense to DISTRICT, unless DISTRICT has agreed to pay CONTRACTOR the premium portion of the overtime rate.
- (e) Should overtime work be required due to delays caused by CONTRACTOR, CONTRACTOR will be responsible for the costs associated with Supervision and Inspection by the DISTRICT. These costs will be deducted from the Contract Sum.

**ARTICLE 50. PAYROLL RECORDS**

- (a) Pursuant to the provisions of Labor Code Section 1776, the CONTRACTOR shall keep and shall cause each Subcontractor performing any portion of the Work under the Contract Documents to keep an accurate payroll record, showing the name, address, Social Security number, work classification, straight time and overtime hours worked each day and week, and the actual per diem wages paid to each journeyman, apprentice, worker, or other employee employed by CONTRACTOR in connection with the Work. Each payroll record shall contain or be verified by a written declaration that is made under penalty of perjury, stating both of the following:
  - (1) The information contained in the payroll record is true and correct.
  - (2) The employer has complied with the requirements of sections 1771, 1811 and 1815 for any work performed by his or her employees on the public works project.
- (b) The payroll records enumerated under subdivision (a) shall be certified and shall be available for inspection at all reasonable hours at the principal office of the CONTRACTOR on the following basis:
  - (1) A certified copy of an employee's payroll record shall be made available for inspection or furnished to the employee or his or her authorized representative on request.
  - (2) A certified copy of all payroll records enumerated in subdivision (a) shall be made available for inspection or furnished upon request to a representative of the DISTRICT, the Division of Labor Standards Enforcement, and the Division of Apprenticeship Standards of the Department of Industrial Relations.
  - (3) A certified copy of all payroll records enumerated in subdivision (a) shall be made available for inspection upon request by the public or copies thereof made; provided, however, that a request by the public shall be made through either the DISTRICT, the Division of Apprenticeship Standards, or the Division of Labor Standards Enforcement. If the requested payroll records have not been provided pursuant to paragraph (2), the requesting party shall, prior to being provided the records, reimburse the costs of preparation by the CONTRACTOR, Subcontractors, and the entity through which the request was made. The public shall not be given access to the records at the principal office of the CONTRACTOR.
  - (4) The form of certification shall be as follows:

I, \_\_\_\_\_ (Name-print), the undersigned, am \_\_\_\_\_  
(position in business) with the authority to act for and on behalf of

00700  
GENERAL CONDITIONS for GENERAL  
CONTRACTOR  
CLOVIS UNIFIED SCHOOL DISTRICT

\_\_\_\_\_(Name of business and/or  
CONTRACTOR), certify under penalty of perjury that the records or copies thereof  
submitted and consisting of \_\_\_\_\_  
(description, number of pages) are the originals or true, full and correct copies of the  
originals which depict the payroll record(s) of the actual disbursements by way of cash,  
check, or whatever form to the individual or individuals named.

Dated: \_\_\_\_\_  
Signature: \_\_\_\_\_

- (c) CONTRACTOR or subcontractor shall file a certified copy of the payroll records enumerated in subdivision (a) with the entity that requested the records within ten (10) days after receipt of a written request. In the event that the CONTRACTOR or subcontractor fails to comply within the 10-day period, the CONTRACTOR or subcontractor shall, as a penalty to the DISTRICT, forfeit twenty-five Dollars (\$25) for each calendar day, or portion thereof, for each worker, until strict compliance is effectuated. Upon the request of the Division of Apprenticeship Standards or the Division of Labor Standards Enforcement, these penalties shall be withheld from progress payments then due. Contractor is not subject to a penalty assessment pursuant to this provision due to the failure of a subcontractor to comply.
- (d) Any copy of payroll records made available for inspection as copies and furnished upon request to the public by the DISTRICT, the Division of Apprenticeship Standards, or the Division of Labor Standards Enforcement shall be marked or obliterated in such a manner as to prevent disclosure of an individual's name, address, and social security number. The name and address of the CONTRACTOR awarded the Contract or the subcontractor performing the Contract shall not be marked or obliterated. Any copy of records made available for inspection by, or furnished to, a joint labor-management committee established pursuant to the federal Labor Management Cooperation Act of 1978 (29 U.S.C. Sec. 175a) shall be marked or obliterated only to prevent disclosure of an individual's name and social security number. A joint labor management committee may maintain an action in a court of competent jurisdiction against an employer who fails to comply with Labor Code section 1774. The court may award restitution to an employee for unpaid wages and may award the joint labor management committee reasonable attorney's fee and costs incurred in maintaining the action. An action may not be based on the employer's misclassification of the craft of a worker on its certified payroll records. Nothing stated herein limits any other available remedies for a violation.
- (e) The CONTRACTOR shall inform the DISTRICT of the location of the payroll records enumerated under subdivision (a), including the street address, city and county, and shall, within five (5) working days, provide a written notice of a change of location and address.

**ARTICLE 51. APPRENTICES**

- (a) The CONTRACTOR acknowledges and agrees that, if the Contract Documents involve a dollar amount greater than or a number of working days greater than that specified in Labor Code Section 1777.5, the provisions of Labor Code Section 1777.5 govern the Contract Documents. It shall be the responsibility of the CONTRACTOR to ensure compliance with this Article and with Labor Code Section 1777.5 for all apprenticing occupations.
- (b) Apprentices of any crafts or trades may be employed and, when required by Labor Code Section 1777.5, shall be employed provided they are properly registered in full compliance with the provisions of the Labor Code.

00700  
GENERAL CONDITIONS for GENERAL  
CONTRACTOR  
CLOVIS UNIFIED SCHOOL DISTRICT

- (c) Every such apprentice shall be paid the prevailing wage paid to apprentices under the regulations of the craft or trade at which he or she is employed, and shall be employed only at the work of the craft or trade to which he or she is registered.
- (d) Only apprentices, as defined in Section 3077, who are in training under apprenticeship standards and written apprentice agreements under Chapter 4 (commencing at Section 3070), Division 3 of the Labor Code, are eligible to be employed on public works. The employment and training of each apprenticeship shall be in accordance with the provisions of the apprenticeship standards and apprentice agreements under which he or she is training or the rules and regulations of the California Apprenticeship Council.
- (e) Pursuant to Labor Code Section 1777.5, the CONTRACTOR and any Subcontractors employing workers in any apprenticeship craft or trade in performing any Work under the Contract Documents shall apply to the applicable joint apprenticeship committee for a certificate approving the CONTRACTOR or Subcontractor under the applicable apprenticeship standards for the employment and training of apprentices.
- (f) Every CONTRACTOR and Subcontractor shall submit contract award information to the applicable joint apprenticeship committee which shall include an estimate of journeyman hours to be performed under the Contract Documents, the number of apprentices to be employed and the approximate dates the apprentices will be employed.
- (g) If the CONTRACTOR or Subcontractor willfully fails to comply with Labor Code Section 1777.5, then, upon a determination of noncompliance by the Chief of the Division of Apprenticeship Standards, it :
  - (1) may be denied the right to bid on any subsequent project for one year from the date of such determination and for a period of three years for any second or subsequent violation;
  - (2) shall forfeit as a penalty to the DISTRICT one hundred dollars (\$100) per day for each calendar day of noncompliance, which shall be withheld from any payment due or to become due under the terms of this Agreement and which may also be reduced or changed by the Chief to apprentice employment rather than a penalty; and
  - (3) shall forfeit as a penalty to the DISTRICT three hundred dollars (\$300) per day for each calendar day of noncompliance.
- (h) The CONTRACTOR and all Subcontractors shall comply with Labor Code Section 1777.6, which section forbids certain discriminatory practices in the employment of apprentices.
- (i) CONTRACTOR shall become fully acquainted with the law regarding apprentices prior to commencement of the Work. Special attention is directed to Sections 1777.5, 1777.6, and 1777.7 of the Labor Code, and Title 8, California Code of Regulations, Section 200 et seq. Questions may be directed to the State Division of Apprenticeship Standards, 455 Golden Gate Avenue, San Francisco, California. The responsibility of compliance with Article 51 is with the CONTRACTOR.

**ARTICLE 52. LABOR - FIRST AID**

- (a) The CONTRACTOR shall maintain emergency first aid treatment for CONTRACTOR's workers on the Project which complies with the Federal Occupational Safety and Health Act of 1970 (29 U.S.C.A., Sec. 651 et seq.).

00700  
GENERAL CONDITIONS for GENERAL  
CONTRACTOR  
CLOVIS UNIFIED SCHOOL DISTRICT

**ARTICLE 53. PROTECTION OF PERSONS AND PROPERTY**

- (a) The CONTRACTOR shall be responsible for all damages to persons or property that occur as a result of its fault or negligence in connection with the prosecution of the Contract Documents and shall take all necessary measures and be responsible for the proper care and protection of all materials delivered and work performed until completion and final acceptance by the DISTRICT. The CONTRACTOR shall remove all mud, water, or other elements as may be required for the proper protection and prosecution of its Work. CONTRACTOR shall provide such heat, covering, and enclosures as are necessary to protect all work, materials, equipment, appliances, and tools against damage by weather conditions. All Work shall be solely at the CONTRACTOR's risk with the exception of damage to the Work caused by "acts of God" as defined in Public Contract Code Section 7105.
- (b) CONTRACTOR shall take, and require Subcontractors to take, all necessary precautions for the safety of workers and shall comply with all applicable federal, state, local and other safety laws, standards, orders, rules, regulations, and building codes to prevent accidents or injury to persons on, about, or adjacent to the Work site and to provide a safe and healthful place of employment. CONTRACTOR shall furnish, erect, properly maintain at all times, and remove as required by other scheduled activities, as directed by DISTRICT or ARCHITECT or as required by the conditions and progress of work, all necessary safety devices, safeguards, construction canopies, signs, audible devices for protection of the blind, safety rails, belts and nets, barriers, lights, and watchmen for protection of workers and the public and shall post danger signs warning against hazards created by such features in the course of construction. CONTRACTOR shall designate a responsible employee, whose duty shall be to post information regarding protection and obligations of workers and other notices required under occupational safety and health laws, to comply with reporting and other occupational safety requirements, and to protect the life, safety, and health of workers. The CONTRACTOR shall report the name and position of the person so designated in writing to DISTRICT. CONTRACTOR shall correct any violations of safety laws, standards, orders, rules, or regulations. Upon the issuance of a citation or notice of violation by the Division of Occupational Safety and Health, the CONTRACTOR at CONTRACTOR's expense shall correct such violation immediately.
- (c) In an emergency affecting safety of person or of Work or of adjoining property, CONTRACTOR, without special instruction or authorization from ARCHITECT or DISTRICT, is hereby permitted to act, at its discretion, to prevent such threatened loss or injury; and CONTRACTOR shall so act if so authorized or instructed by ARCHITECT or DISTRICT. Any compensation claimed by CONTRACTOR on account of emergency work shall be determined by written agreement with the DISTRICT.
- (d) CONTRACTOR shall take adequate precautions to protect existing roads, sidewalks, curbs, pavements, utilities, adjoining property and structures (including, without limitation, protection from settlement or loss of lateral support), and to avoid damage thereto, and repair any damage thereto caused by construction operations.
- (e) CONTRACTOR shall (unless waived by the DISTRICT in writing):
- (1) When performing new construction on existing sites, become informed and take into specific account the maturity of the students on the site; and perform work which may interfere with school routine before or after school hours; enclose working area with a substantial barricade; and arrange work to cause a minimum amount of inconvenience and danger to students and faculty in their regular school activities.

00700  
**GENERAL CONDITIONS for GENERAL  
 CONTRACTOR  
 CLOVIS UNIFIED SCHOOL DISTRICT**

- (2) Provide substantial barricades around any shrubs or trees indicated to be preserved.
- (3) Deliver materials to the building area over the route designated by ARCHITECT.
- (4) When directed by DISTRICT, take preventive measures to eliminate objectionable dust caused by CONTRACTOR's work. Should the contractor not maintain proper dust control the DISTRICT will provide dust control with all costs being the responsibility of the CONTRACTOR.
- (5) Enforce all instructions of DISTRICT and ARCHITECT regarding signs, advertising, fires, and smoking and require that all workers comply with all regulations while on construction site.
- (6) Take care to prevent disturbing or covering any survey markers, monuments, or other devices marking property boundaries or corners. If such markers are disturbed by accident, an approved civil engineer at no cost to the DISTRICT shall replace them.

**ARTICLE 54. NON-DISCRIMINATION**

- (a) In the performance of the terms of this Agreement, CONTRACTOR agrees that it will not engage in nor permit such Subcontractor as it may employ to engage in unlawful discrimination in employment of persons because of the race, religious creed, color, national origin, ancestry, physical handicap, medical condition, marital status, or sex of such persons.

**ARTICLE 55. SCHEDULE OF VALUES AND PROGRESS PAYMENT APPLICATIONS**

- (a) CONTRACTOR shall furnish on a form approved by DISTRICT:
  - (1) Within **ten (10) days** of Notice to Proceed and commensurate with the specification section entitled **SCHEDULE OF VALUES**, provide a detailed preliminary estimate giving a complete breakdown of Contract Price for each area of the project and/or site, which shall include all Subcontractor/supplier agreements showing the dollar amounts of these agreements to justify the schedule of values, and showing separate line items for the material cost(s) and installation cost(s).
  - (2) A periodical itemized estimate of Work done for purpose of making partial payments thereon.
  - (3) Within **ten (10) days** of a request by DISTRICT, a schedule of estimated monthly payments which shall be due CONTRACTOR under the **Contract Documents**.
- (b) Values employed in making up any of these schedules are subject to the ARCHITECT's written approval and will be used only for determining the basis of partial payments and will not be considered as fixing a basis for additions to or deductions from contract price.
  - (1) Unless otherwise agreed in writing, payment for CONTRACTOR's mobilization costs shall be cost loaded as follows:

<b>Contract Completion Percentage</b>	<b>Payment for Mobilization Percentage</b>
When 5% of the Contract Sum is billed, then...	50% of mobilization cost can be billed.
When 10% of the Contract Sum is billed, then...	25% of mobilization cost can be billed.
When 20% of the Contract Sum is billed, then...	20% of mobilization cost can be billed.



00700  
GENERAL CONDITIONS for GENERAL  
CONTRACTOR  
CLOVIS UNIFIED SCHOOL DISTRICT

When 50% of the Contract Sum is billed, then...	5% of mobilization cost can be billed.
--	--

- (c) Materials included in the progress payments shall be stored properly and protected as required to prevent damage, including but not limited to, rust, dents, scratches, and decay. Materials stored on-site and subject to payment, shall be gated and secured to prevent theft and/or vandalism. When the CONTRACTOR requests payment for materials not incorporated in the Work, the following terms and conditions shall apply:
- (1) For permanent materials delivered to the project site, or stored in an approved location off-site, an allowance of one hundred percent (100%) of the material costs plus freight charges as invoiced and less retention may be made. The allowance will be based upon validated invoices or bills for such materials, including freight charges, and a copy thereof shall be made a part of the documented records for the project. All permanent materials approved for payment will have been tested by the DISTRICT for compliance with the requirements of the Contract Documents. Payment will only be made for permanent materials that conform to the requirements of the Contract Documents.
  - (2) No allowance shall be made for fuels, form lumber, false work, temporary structures, or other materials of any kind that will not become an integral part of the finished contraction.
  - (3) All permanent materials, for which an allowance is requested, shall be stored in an approved manner where damage is not likely to occur. If any of the store materials are lost or become damages in any manner, CONTRACTOR shall be responsible for repairing or replacement of such damaged materials. The value of the lost or damaged materials permanent materials shall be deducted from the CONTRACTOR's subsequent progress payments until replacement has been accomplished.
  - (4) Permanent materials, for which payment has been made, either wholly or partially, shall not be removed from the approved location until such time that it is incorporated into the Work, unless approved by the DISTRICT and/or the ARCHITECT.
  - (5) The following must accompany the written request for payment of stored materials, if required by the DISTRICT:
    - (A) Consent of the Surety specifying the material type and the bid items in which the material is to be used.
    - (B) Validating invoices showing that payment for the material has been made.
    - (C) A notarized statement from CONTRACTOR attesting that the invoices, as submitted do not include charges and/or fees for placing, handling, erecting or any other charges and/or markups other than the actual material cost, sales tax(es) if applicable, and freight charges.
    - (D) Bill of lading showing delivery of the material.
    - (E) Inspection test reports, and certifications if required by the Contract Documents.
    - (F) CONTRACTOR shall obtain a negotiable warehouse receipt, endorsed over to DISTRICT for materials and/or equipment stored in an off-site warehouse.
    - (G) Certificate of insurance clearly indicating that the materials or equipment is fully insured against theft, fire, vandalism, malicious mischief, as well as other coverage required under the Contract Documents.
  - (6) Nothing in these General Conditions shall be interpreted as requiring DISTRICT to pay for stored materials. DISTRICT shall decide on a case-by-case basis whether it will pay for stored materials. Some factors DISTRICT will consider are: CONTRACTOR's ability to meet the Project Schedule and milestones, the effectiveness of CONTRACTOR's quality

00700  
GENERAL CONDITIONS for GENERAL  
CONTRACTOR  
CLOVIS UNIFIED SCHOOL DISTRICT

control plan, how record drawings are being maintained and kept up, the status of the material submittals, and the on-going cleanliness of the Project and the Project Site. No payment will be made for stored materials that have not been submitted and accepted.

- (7) If the permanent materials are stored off-site, CONTRACTOR must pay DISTRICT's representative's transportation and lodging to see the permanent materials.
  - (8) Full title to the materials and/or equipment shall vest with DISTRICT at the time of delivery to the site, warehouse, or other storage location.
- (d) Commensurate with the Articles entitled PAYMENTS and WAIVER AND RELEASE FORMS and other requirements of the Contract, and upon receipt of the ARCHITECT's approval of the Request for Payment, the DISTRICT will subtract a sum equal to five percent (5%) of the value of the Work performed up to the last day of the previous month, less the aggregate of previous payments. The value of the Work completed shall be an estimate only. No inaccuracy or error in said estimate shall operate to release the CONTRACTOR, or any surety, from damages arising from such Work or from enforcing each and every provision of this Contract, and the DISTRICT shall have the right subsequently to correct any error made in any estimate for payment. The CONTRACTOR shall not be entitled to have any payment requests processed, or be entitled to have any payment made for Work performed, so long as any lawful or proper direction given by the DISTRICT concerning the Work, or any portion thereof, remains uncomplied with. At any time after fifty percent (50%) of the Contract work has been completed and the DISTRICT's Board, in its sole discretion, finds that satisfactory progress is being made, the DISTRICT may choose not to subtract the retention from remaining payment requests, and upon receipt of the CONTRACTOR's bonding company letter of approval for such.
- (e) DISTRICT shall have the right, if necessary for the protection of the DISTRICT, to issue joint checks made payable to the CONTRACTOR and Subcontractors and/or material or equipment suppliers. The joint check payees shall be responsible for the allocation and disbursement of funds included as part of any such joint payment. However, DISTRICT has no duty to issue joint checks. In no event shall any joint check payment be construed to create any contract between the DISTRICT and a Subcontractor of any tier, any obligation from the DISTRICT to such Subcontractor, or rights in such Subcontractor against the DISTRICT.

**ARTICLE 56. CONTRACTOR CLAIMS**

- (a) If the CONTRACTOR claims compensation for any damage sustained by reason of the acts of the DISTRICT or its agents, or if the CONTRACTOR disagrees with the DISTRICT's or Architect's decisions regarding a CONTRACTOR's Change Order Request (COR), the CONTRACTOR shall provide written "Notice" to the DISTRICT **within (5) days** of the earliest of the following events: (a) the Completion of the Work; (b) the thirtieth (30th) continuous day without labor by Contractor; or (c) Contractor's submission of a final payment application, and provide within **fourteen (14) days** of that event the factual basis supporting the claim (unless otherwise specified in writing by the DISTRICT). The written "Notice" shall state the summary points for which the factual basis will support the claim and cite in detail the Contract Documents (including plans and specifications) upon which the claim is to be based. CONTRACTOR's failure to notify the DISTRICT within such a period shall be deemed a waiver and relinquishment of such a claim. If such notice is given within the specified time, District shall respond in accordance with the procedures set forth herein. Refer to the Articles entitled, "**DEFINITIONS**", "**DISPUTES - CLAIMS PROCEDURE**", "**CHANGES AND EXTRA WORK**", "**NOTICE**" and "**WAIVER AND RELEASE FORMS**" for related Contract requirements.
- (b) In addition, on or before the end of the month for which the claim has been filed, the CONTRACTOR shall also file with the DISTRICT the **WAIVER AND RELEASE FORMS**, for

00700  
GENERAL CONDITIONS for GENERAL  
CONTRACTOR  
CLOVIS UNIFIED SCHOOL DISTRICT

which the claim and the amount of the claim are identified. If the claim is not indicated on the **WAIVER AND RELEASE FORMS**, CONTRACTOR's claim shall be forfeited and invalidated and it shall not be entitled to consideration for time or payment on account of any such claim.

- (c) Pending final resolution of any Claim, unless otherwise agreed to in writing, the CONTRACTOR shall proceed diligently with performance of the Work, and the DISTRICT shall continue to make any undisputed payments in accordance with the Contract Documents.
- (d) The CONTRACTOR shall certify, at the time of submission of a claim, as follows:

I, \_\_\_\_\_, being the \_\_\_\_\_ (Must be an officer) of \_\_\_\_\_ (CONTRACTOR), declare under penalty of perjury under the laws of the State of California, and do personally certify and attest that: I have thoroughly reviewed the attached claim for additional cost and/or extension of time, and know its contents, and said claim is made in good faith; the supporting data is truthful, accurate and complete; that the amount requested accurately reflects the adjustment for which the CONTRACTOR believes the DISTRICT is liable; and further, that I am familiar with California Penal Code section 72 pertaining to false claims, and further know and understand that submission or certification of a false claim may lead to fines, imprisonment and/or other severe legal consequences.

By: \_\_\_\_\_

CONTRACTOR understands and agrees that any claim submitted without this certification does not meet the terms of the Contract Documents, that DISTRICT or DISTRICT representatives, may reject the claim on that basis and that unless CONTRACTOR properly and timely files the claim with the certification, CONTRACTOR cannot further pursue the claim in any forum. A condition precedent will not have been satisfied.

- (e) Failure to request money based on costs, or time extensions, as part of a COR constitutes a complete waiver of CONTRACTOR's right to claim the omitted money or time. All money or time for an issue must be included in the COR at the time submitted.

**ARTICLE 57. DISPUTES – CLAIMS PROCEDURE**

- (a) Claims shall be handled pursuant to the procedures set forth in Public Contract Code section 9204, including claim, written response, payments, meet and confer conference, statement of disputed and undisputed portions after the meet and confer conference and non-binding mediation, and Government Code claim provisions as set forth below. In addition, for claims that are \$375,000 or less, the provisions of Public Contract Code section 20104 et. seq. also apply, to the extent they do not conflict with Public Contract Code section 9204.
  - (1) DISTRICT shall conduct a reasonable review of the claim and shall respond in writing to any written claim within 45 days of receipt of the claim. During that 45 day period, plus any extension, DISTRICT may request in writing additional documentation supporting the claim or relating to defenses to the claim the DISTRICT may have against the CONTRACTOR. DISTRICT shall review any additional documentation CONTRACTOR supplies in response to that request within the 45 day, plus any extension, timeline. After receipt of a claim, the 45-day period may be extended by DISTRICT and CONTRACTOR. The written response shall identify which portion of the claim is disputed and what portion is undisputed. If DISTRICT needs approval from its governing board to provide the written response, and the governing board does not meet within the 45 days or any extended period of time, then the DISTRICT shall have up to

**00700**  
**GENERAL CONDITIONS for GENERAL**  
**CONTRACTOR**  
**CLOVIS UNIFIED SCHOOL DISTRICT**

three days after the next publicly noticed meeting of the governing board to provide the written response. Any payment due on an undisputed portion of the claim shall be processed and made within sixty (60) days after the DISTRICT issues the written response. DISTRICT's failure to respond to a claim within the above time periods or to otherwise meet the above time requirements shall result in the claim being deemed rejected in its entirety.

- (2) If the CONTRACTOR disputes the DISTRICT's written response, or the DISTRICT fails to respond within the time prescribed, the CONTRACTOR may so notify the DISTRICT, in writing, either within 15 days of receipt of the DISTRICT's response or within 15 days of the DISTRICT's failure to respond within the time prescribed, respectively, and demand an informal conference to meet and confer for settlement of the issues in dispute. Upon a written demand sent by registered or certified mail return receipt requested, the DISTRICT shall schedule a meet and confer conference for settlement of the dispute, which shall take place within 30 days of the demand. Upon written agreement of the DISTRICT and CONTRACTOR, the conference may take place during regularly scheduled Project meetings. If CONTRACTOR fails to timely notify the DISTRICT that it wishes to meet and confer, then CONTRACTOR will have waived all rights to (a) recover money or time on the issues for which a claim was required, (b) submit a Government Code claim for such money or time, and (c) initiate any action, proceeding or litigation for such money or time. CONTRACTOR will not have satisfied a condition precedent or exhausted administrative remedies.
- (3) Within ten (10) business days after the conclusion of the meet and confer conference, the DISTRICT shall give a written statement to the CONTRACTOR identifying the portion of the claim that remains in dispute and the portion that is undisputed. Any payment due on an undisputed portion of the claim shall be processed and made within sixty (60) days after the DISTRICT issues the written statement. Within ten (10) business days of issuance of DISTRICT's written statement, CONTRACTOR shall identify in writing the disputed portion of the claim that shall be submitted to non-binding mediation (which may consist of any nonbinding process, including but not limited to neutral evaluation or a dispute review board), with the DISTRICT and CONTRACTOR sharing the costs equally. The DISTRICT and CONTRACTOR shall mutually agree to a mediator within ten (10) business days after the CONTRACTOR has identified in writing the disputed portion of the claim. If they cannot agree upon a mediator, then each shall select a mediator and those two mediators shall select a qualified neutral third party to mediate the disputed portion of the claim. (Each party shall bear the fees and costs its respective mediator charged in connection with the selection of the neutral mediator). The parties may mutually waive in writing the requirement for mediation. If CONTRACTOR fails to timely notify the DISTRICT in writing that it wishes to mediate pursuant to this paragraph, CONTRACTOR will have waived all right to further pursue the claim. The parties shall reasonably cooperate to schedule and attend a mediation as soon as reasonably possible. DISTRICT's failure to respond to the claim within the above time periods or to otherwise meet the above time requirements shall result in the claim being deemed rejected in its entirety.
- (4) If the claim or any portion remains in dispute after the mediation and CONTRACTOR wishes to pursue it, the CONTRACTOR must file a timely and proper Government Code claim. The filing of a Government Code claim is specifically required in addition to all contractual procedures described herein. Failure to timely file a Government Code claim shall act as complete waiver of CONTRACTOR's rights to (a) recover money or time on the issues for which a Government Code claim was required, and (b) initiate any action, proceeding or litigation for such money or time. CONTRACTOR will not have satisfied a condition precedent or exhausted administrative remedies. DISTRICT and

00700

**GENERAL CONDITIONS for GENERAL  
CONTRACTOR  
CLOVIS UNIFIED SCHOOL DISTRICT**

CONTRACTOR shall proceed with the Government Code claim according to Government Code, Section 900 et seq., and as otherwise permitted by law. For purposes of the applicable Government Code provisions, and as provided in Public Contract Code section 20104.2(e), the running of the time period within which a CONTRACTOR must file a Government Code claim shall be tolled from the time the CONTRACTOR submits a written claim until the time that the claim is denied.

- (a) Despite submission or rejection of a COR or claim, the CONTRACTOR shall proceed diligently with performance of the Work as directed by DISTRICT, and the DISTRICT shall continue to make any undisputed payments in accordance with the Contract Documents.
- (b) All meetings and correspondence relative to disputes and claims, which involve offers of good faith and negotiations, are subject to the Evidence Code section 1152 exclusions.

**ARTICLE 58. PAYMENTS**

- (a) Each month, on a date to be determined by the DISTRICT, the CONTRACTOR shall be entitled to submit a progress payment invoice for unpaid Work provided to the DISTRICT. The invoice shall be on a form approved and/or provided by the DISTRICT and submitted to the PROJECT INSPECTOR for review. Within **seven (7) days** of submission, the ARCHITECT will review the CONTRACTOR's invoice for legitimacy, and if any corrections or adjustments are required, CONTRACTOR shall be required to resubmit the corrected invoice within **three (3) days** of the request. Upon receipt of the corrected invoice, the ARCHITECT will verify the corrections. DISTRICT, within **thirty (30) days** after receipt of the invoice from the ARCHITECT shall pay the CONTRACTOR a sum equal to ninety-five percent (95%) of value of the CONTRACTOR's invoice. Payments for Change Order items can be included in the CONTRACTOR's invoice, that is after the Change Order has been fully executed and approved by the DISTRICT Governing Board and/or authorized representative. ARCHITECT will endeavor to provide DISTRICT with signed copies of the CONTRACTOR's invoice on or before **seven (7) days** of receipt from CONTRACTOR. Work completed as estimated shall be an estimate only and no inaccuracy or error in said estimate shall operate to release CONTRACTOR or Surety from any damages arising from such work or from enforcing each and every provision of the Contract Documents, and DISTRICT shall have the right subsequently to correct any error made in any estimate for payment. CONTRACTOR SHALL NOT BE ENTITLED TO HAVE ANY PAYMENT ESTIMATES PROCESSED OR BE ENTITLED TO HAVE ANY PAYMENT FOR WORK PERFORMED SO LONG AS ANY LAWFUL OR PROPER DIRECTION CONCERNING WORK, OR ANY PORTION THEREOF, GIVEN BY THE DISTRICT OR ARCHITECT REMAINS UNCOMPLIED WITH BY THE CONTRACTOR.
- (b) DISTRICT has discretion to require from the CONTRACTOR any of the following information with the application for payment:
  - (1) certified payroll covering the period of the prior application for payment;
  - (2) unconditional waivers and releases from all Subcontractors/suppliers for which payment was requested under the prior application for payment;
  - (3) receipts or bills of sale for any items.
  - (4) Signature of the Inspector, confirming that the maintenance of the Record Drawings is being kept up-to-date, and that the Record Drawings are not being used as a construction set.
- (c) Before payment is made hereunder, a certificate in writing shall be signed by the Project Inspector stating the Contract Documents have been adhered to and to confirm the estimates in the certification of application for payment, then submitted to the ARCHITECT. The ARCHITECT shall state the work for which the payment is claimed has been performed in general conformance with the terms of the Contract Documents and that the amount stated in

00700  
GENERAL CONDITIONS for GENERAL  
CONTRACTOR  
CLOVIS UNIFIED SCHOOL DISTRICT

the certificate is due under the terms of the Contract Documents, in which the certificate shall be attached to and made a part of the application made and filed with the DISTRICT, provided that if the ARCHITECT or the Project Inspector shall, within **three (3) days** after written demand therefore, fail to deliver such certificate to the DISTRICT, the CONTRACTOR may file its application with the DISTRICT without said certificate, but together with such application shall file a statement that demand was made for such certificate and that the same was refused. Thereupon, the DISTRICT will either allow said application as presented or shall reject all or part of it. It is understood, moreover, that the certificate of the ARCHITECT shall not be conclusive upon the DISTRICT, but shall be advisory only.

- (d) NO PAYMENT BY DISTRICT HEREUNDER SHALL BE INTERPRETED SO AS TO IMPLY THAT DISTRICT HAS INSPECTED, APPROVED, OR ACCEPTED ANY PART OF THE WORK. The final payment of five percent (5%) of the value of the Work done under the Contract Documents, if unencumbered, shall be made **thirty-five (35) days** after recording by the DISTRICT of the Notice of Completion. ACCEPTANCE WILL BE MADE ONLY BY ACTION OF THE GOVERNING BOARD OF DISTRICT.
- (e) Unless otherwise provided, on or before making request for final payment of the undisputed amount due under the Contract Documents, CONTRACTOR shall submit to DISTRICT, in writing a summary of all claims for compensation under or arising out of the Contract Documents which were timely filed. The acceptance by CONTRACTOR of the payment of the final amount shall constitute a waiver of all claims against DISTRICT under or arising out of the Contract Documents, except those previously made, in a timely manner and in writing, and identified by CONTRACTOR as unsettled at the time of CONTRACTOR's final request for payment.

**ARTICLE 59. CHANGES AND EXTRA WORK**

- (a) DISTRICT may, as provided by law and without affecting the validity of the Contract Documents, order changes, modifications, deletions, and extra work by issuance of written change orders from time to time during the progress of the Project, with the Contract Sum and time being adjusted accordingly. All such work shall be executed under conditions of the original Contract Documents. DISTRICT has discretion to order changes on a "Unit Price," "Negotiated Sum," or "Time and Material" basis with adjustments to time made after CONTRACTOR has justified the impact on the critical path of the Project. The following records shall also be kept by CONTRACTOR:
  - (1) CONTRACTOR shall maintain its records in such a manner as to provide a clear distinction between the direct costs of any extra work and/or deductive work and the original Contract Work. This requirement pertains to the costs for wholly or partially approved Change Order Requests (COR's), Construction Change Directives (CCD's), Change Orders (CO's) and work CONTRACTOR considered to be potential Change Orders.
  - (2) CONTRACTOR shall furnish within seven (7) days after the Notice to Proceed, a complete listing of CONTRACTORS and Subcontractors hourly labor rates, indicating the direct hourly wage rate, payroll taxes and insurance costs.
- (b) Notwithstanding any other provision in the Contract Documents, the adjustment in the Contract Sum, if any, and the adjustment in the Contract Time, if any, set out in a change order shall constitute the entire compensation and/or adjustment in the Contract Time due CONTRACTOR arising out of the change in the work covered by the change order unless otherwise provided in the change order. The amount of the compensation due CONTRACTOR shall be calculated pursuant to **subparagraph (e)** of this Article. The entire compensation shall not include any additional charges not set forth in **subparagraph (e)** and shall not include delay damages (due

00700

**GENERAL CONDITIONS for GENERAL  
CONTRACTOR  
CLOVIS UNIFIED SCHOOL DISTRICT**

to processing of a change order, refusal to sign a change order) indirect, consequential, and incidental costs including any Project management costs, extended home office and field office overhead, administrative costs and profit other than those amounts authorized under **subparagraph (e)** of this Article.

- (c) In giving instructions, ARCHITECT shall have authority to make minor changes in the Work, not involving a change in cost, and not inconsistent with the purposes of the Project. The DISTRICT's authorized representative may authorize changes in work involving a change in cost and/or time. Except in an emergency endangering life or property, no extra work or change shall be made unless pursuant to a written order from DISTRICT, authorized by DISTRICT'S representative, and no claim for addition to Contract Sum shall be valid unless so ordered.
- (d) If the ARCHITECT determines that work required to be done constitutes extra work outside the scope of the Contract Documents, the ARCHITECT shall issue a request for a detailed proposal (RFP) or issue a Construction Change Directive (CCD) to the CONTRACTOR. CONTRACTOR will respond with a detailed proposal (COR) upon receipt of the RFP or CCD within fourteen (14) days of receipt of such documents. If the work is to be performed by a Subcontractor, CONTRACTOR must include a detailed bid from the Subcontractor.
- (e) Value of any such extra work, change, or deduction shall be determined at the discretion of DISTRICT in one or more of the following ways:
  - (1) By "**Unit Prices**" contained in CONTRACTOR's original bid and incorporated in the Contract Documents or fixed by subsequent "**Negotiated Sum**" agreement between DISTRICT and CONTRACTOR.
  - (2) By cost of labor and material and percentage for overhead and profit ("**time and material**"). If the value is determined by this method the following requirements shall apply:
    - (A) Daily Reports by CONTRACTOR.
      - (i) General. At the close of each working day, the CONTRACTOR shall submit a daily report to the Inspector, on forms approved by the DISTRICT, together with applicable delivery tickets, listing all labor, materials, and equipment involved for that day, and for other services and expenditures when authorized concerning extra work items, including any schedule delay days required. An attempt shall be made to reconcile the report daily, and the Inspector and the CONTRACTOR shall sign it. In the event of disagreement, pertinent notes shall be entered by each party to explain points that cannot be resolved immediately. Each party shall retain a signed copy of the report. Reports by Subcontractors or others shall be submitted through the CONTRACTOR. The CONTRACTOR shall organize and forward copies of the CONTRACTOR's and Inspector's reports to the ARCHITECT upon the completion of each "Time and Material" activity. ANY REPORTS NOT SUBMITTED IN A TIMELY MANNER AND NOT SIGNED BY THE INSPECTOR SHALL NOT BE CONSIDERED AS A PART OF THE COSTS CONSIDERED FOR THE CHANGE ORDER. THE CONTRACTOR SHALL NOTIFY THE INSPECTOR PRIOR TO STARTING THE WORK EACH DAY.
      - (ii) Labor. The report shall show names of workers, classifications, and hours worked and hourly rate. Project Superintendent expenses are not allowed.
      - (iii) Tool and Equipment Rental. No payment will be made for the use of tools which have a replacement value of **\$250** or less or where an invoice is not provided.

00700

**GENERAL CONDITIONS for GENERAL  
CONTRACTOR  
CLOVIS UNIFIED SCHOOL DISTRICT**

Regardless of ownership, the rates to be used in determining equipment rental costs shall not exceed listed rates prevailing locally at equipment rental sources, or distributors, at the time the work is performed. The rental rates paid shall include the cost of fuel, oil, lubrication, supplies, small tools, necessary attachments, repairs, and maintenance of any kind, depreciation, storage, insurance, and all incidentals. Necessary loading and transportation costs for equipment used on the extra work shall be included.

If equipment is used intermittently and, when not in use, could be returned to its rental source at less expense to the DISTRICT than holding it at the Work site, it shall be returned, unless the CONTRACTOR elects to keep it at the Work site at no expense to the DISTRICT.

All equipment shall be acceptable to the ARCHITECT, in good working condition, and suitable for the purpose for which it is to be used. Manufacturer's ratings and manufacturer's approved modifications shall be used to classify equipment and it shall be powered by a unit of at least the minimum rating recommended by the manufacturer.

- (iv) Equipment. The report shall show type of equipment, size, identification number, and hours of operation, including loading and transportation, if applicable, and hourly/daily cost.
- (v) Other Services and Expenditures. Other services and expenditures shall be described in such detail as the DISTRICT may require.

(B) Basis for Establishing Costs

- (i) Labor. The costs of labor will be the actual cost for wages prevailing locally for each craft classification or type of workers at the time the extra work is done, plus employer payments of payroll taxes and insurance, health and welfare, pension, vacation, apprenticeship funds, and other direct costs resulting from federal, state or local laws, as well as assessments or benefits required by lawful collective bargaining agreements. In no event shall the total cost of all employer payments exceed 20% of the actual cost for wages. The use of labor classifications, which would increase the extra work cost, will not be permitted unless the CONTRACTOR establishes the necessity for such additional costs. Labor costs for equipment operators and helpers shall be reported only when such costs are not included in the invoice for equipment rental.
- (ii) Materials. The cost of materials reported shall be at invoice or lowest current price at which such materials are locally available and delivered to the Work site in the quantities involved, plus sales tax, freight and delivery. The DISTRICT reserves the right to approve materials and sources of supply, or to supply materials to the CONTRACTOR if necessary for the progress of the Work. No markup shall be applied to any material provided by the DISTRICT.
- (iii) Tool and Equipment Rental. No payment will be made for the use of tools which have a replacement value of \$250 or less or where an invoice is not provided. Regardless of ownership, the rates to be used in determining equipment rental costs shall not exceed listed rates prevailing locally at equipment rental source, or distributors, at the time the work is performed. The rental rates paid shall include the cost of fuel, oil, lubrication, supplies, small tools, necessary attachments, repairs, and maintenance of any kind, depreciation, storage, insurance, and all incidentals. Necessary loading and transportation costs for equipment used on the extra work shall be included. If equipment is used



00700

**GENERAL CONDITIONS for GENERAL CONTRACTOR**

**CLOVIS UNIFIED SCHOOL DISTRICT**

intermittently and, when not in use, could be returned to its rental source at less expense to the DISTRICT than holding it at the Work site, it shall be returned, unless the CONTRACTOR elects to keep it at the Work site at no expense to the DISTRICT. All equipment shall be acceptable to the ARCHITECT, in good working condition, and suitable for the purpose for which it is to be used. Manufacturer's ratings and manufacturer's approved modifications shall be used to classify equipment and it shall be powered by a unit of at least the minimum rating recommended by the manufacturer.

- (iv) Other Items. The DISTRICT may authorize other items, which may be required on the extra work. Such items include labor, services, material, and equipment which are different in their nature from those required by the Work and which are of a type not ordinarily available from the CONTRACTOR or any of the Subcontractors. Invoices covering all such items in detail shall be submitted with the request for payment.
  - (v) Invoices. Vendors' invoices for material, equipment rental, and other expenditures shall be submitted with the request for payment. If invoices or other documentation does not substantiate the request, the DISTRICT may establish the cost of the item involved at the lowest price, which was current at the time of the report.
- (3) The following form for "EXTRA WORK and/or DEDUCTIVE WORK" and the "OVERHEAD & PROFIT (O&P) PERCENTAGE SCHEDULE" shall be used as applicable by the provision in the Contract Documents, the CONTRACTOR shall provide written "Notice" to the DISTRICT **within five (5) days** after sustaining of such damage, or being notified of an adverse decision, and provide within **fourteen (14) days** of the event the factual basis supporting the claim (unless otherwise specified). The written "Notice" shall state the summary points for which the factual bases will support the claim and cite in detail the Contract Documents (including plans and specifications) upon which the claim is to be based. CONTRACTOR's failure to notify the DISTRICT within such a period shall be deemed a waiver and relinquishment of such a claim. If such notice is given within the specified time, the procedure for its consideration shall be as stated above in these General Conditions. Refer to the Articles entitled, "**DEFINITIONS**," "**CONTRACTOR CLAIMS**," "**DISPUTES – CLAIMS PROCEDURE**," "**NOTICE**" and "**WAIVER AND RELEASE FORMS**" for related Contract requirements. The claim, once submitted, shall be a "Certified Claim."

In addition, on or before the end of the month for which the claim has been filed, the CONTRACTOR shall also file with the DISTRICT the **WAIVER AND RELEASE FORMS**, for which the claim and amount of the claim is identified. If the claim is not indicated on the **WAIVER AND RELEASE FORMS**, CONTRACTOR's claim shall be forfeited and invalidated and it shall not be entitled to consideration for time or payment on account of any such claim.

- (4) If DISTRICT and CONTRACTOR fail to agree to the quantification of costs and/or time to be placed into a Change Order, the DISTRICT at its own discretion may issue a Construction Change Directive (CCD) for those costs and/or time impacts that is deemed appropriate for the changed work conditions. Notwithstanding the lack of agreement upon a Change Order, the CONTRACTOR shall proceed immediately with the changed work upon receipt of a CCD. If CONTRACTOR disputes the CCD, CONTRACTOR may make a claim pursuant to the Article entitled "**DISPUTES**".

*--- The remaining portion of this page has been left blank ---*

00700  
 GENERAL CONDITIONS for GENERAL  
 CONTRACTOR  
 CLOVIS UNIFIED SCHOOL DISTRICT

**FORM FOR EXTRA WORK AND/OR DEDUCTIVE WORK**

SUBCONTRACTOR WORK (list each if more than one)		ADDITIVE	DEDUCTIVE
1	SUBCONTRACTOR LABOR TOTAL ①	\$ _____	\$ _____
2	SUBCONTRACTOR MATERIAL TOTAL ①,	\$ _____	\$ _____
3	SUBCONTRACTOR EQUIPMENT TOTAL ①,	\$ _____	\$ _____
4	<b>SUBTOTAL #1 (LINES 1, 2 &amp; 3)</b>	\$ _____	\$ _____
5	SUBCONTRACTOR'S OVERHEAD AND PROFIT FOR SUBTOTAL #1 (LINE 4) ③	\$ _____	\$ _____
6	<b>SUBTOTAL #2 (LINES 4 &amp; 5) ④</b>	\$ _____	\$ _____

CONTRACTOR'S WORK		ADDITIVE	DEDUCTIVE
7	CONTRACTOR LABOR TOTAL ①	\$ _____	\$ _____
8	CONTRACTOR MATERIAL TOTAL ①,	\$ _____	\$ _____
9	CONTRACTOR EQUIPMENT TOTAL ①,	\$ _____	\$ _____
10	<b>SUBTOTAL #3 (LINES 7, 8 &amp; 9)</b>	\$ _____	\$ _____
11	CONTRACTOR'S OVERHEAD AND PROFIT FOR SUBTOTAL #3 (LINE 10) ③	\$ _____	\$ _____
12	CONTRACTOR'S OVERHEAD AND PROFIT FOR SUBTOTAL #2 (LINE 6) ③	\$ _____	\$ _____
13	<b>SUBTOTAL #4 (LINES 10, 11 &amp; 12)</b>	\$ _____	\$ _____

14	<b>SUM OF SUBTOTALS #2 &amp; #4</b>	\$ _____	\$ _____
----	-------------------------------------	----------	----------

15	<b>CONTRACTOR'S BOND</b>	\$ _____	\$ _____
16	<b>NET TOTAL FOR C.O.R. (5) □</b>	\$ _____	

- ①: Attach itemized list(s) indicating hours, rates, material quantity, material costs, and unit costs
- ②: Include the cost for taxes.
- ③: Refer to the Overhead and Profit Schedule
- ④: Contractor's bond and liability insurance premium, if in fact actual bonds and insurance are to be purchased. Total costs shall not exceed 2% of the Net Total (line 16). Refer to the O&P Schedule.
- (5) Includes all direct and indirect costs, including but not limited to, acceleration, cumulative effect of the change(s), expediting the Work, Fragnets, etc.

00700  
**GENERAL CONDITIONS for GENERAL  
 CONTRACTOR  
 CLOVIS UNIFIED SCHOOL DISTRICT**

NOTE: OVERHEAD AND PROFIT SHALL BE CALCULATED ON THE NET AMOUNT OF THE CHANGE ORDER

**OVERHEAD & PROFIT (O&P) PERCENTAGE SCHEDULE**

- (i) Refer to the O&P Schedule below. The cost of the work does not include the overhead and profit mark-up's.
- (ii) For all work, the CONTRACTOR's Bond and Liability Insurance Premium may be added in onto the "Form for EXTRA WORK and/or DEDUCTIVE WORK."
- (iii) The O&P Schedule shall be used for "Negotiated Sum" and/or "Time and Materials" work. Unit Price work shall not have the overhead and profit mark-up applied to the work, on the basis that the Unit Price includes overhead and profit margins.

	Work by Subcontractor less than or equal to \$2,500	Work by Subcontractor more than \$2,500	Work by CONTRACTOR less than or equal to \$2,500	Work by CONTRACTOR more than \$2,500
<b>Subcontractor Overhead &amp; Profit</b>	20%	15%		
<b>CONTRACTOR Overhead &amp; Profit</b>	10% Excluding Bond Premium	5% Excluding Bond Premium	15% Excluding Bond Premium	10% Excluding Bond Premium
<b>Total Overhead and Profit, not to exceed:</b>	30%	20%	15%	10%

- (4) For "Negotiated Sum" and "Time and Material" pricing methods, the specified overhead and profit figures are defined and are agreed to include, but not limited to, the following:

- (A) Home office administration costs
- (B) Job site administration costs
- (C) Small tools (Less than \$250 capital cost per item)
- (D) Project staff and company vehicles
- (E) Change Order preparation, procurement and set-up (including all payroll costs and fringe benefits), estimating, supervising, expediting, drafting, and clerical/secretarial services.
- (F) As-Built Drawing maintenance
- (G) General Supervision of the work (Direct Supervision may be included)
- (H) Time & Material documentation procedures
- (I) The handling, transportation and warehousing of materials other than direct identifiable cost of specific deliveries, or as included in the price of the material.
- (J) Time Extension request or recovery schedule preparation

- (5) IT IS EXPRESSLY UNDERSTOOD THAT THE VALUE OF SUCH EXTRA WORK OR CHANGES, AS DETERMINED BY ANY OF THE AFOREMENTIONED METHODS, EXPRESSLY INCLUDES ANY AND ALL OF CONTRACTOR'S COSTS AND EXPENSES, BOTH DIRECT AND INDIRECT, RESULTING FROM ADDITIONAL TIME REQUIRED ON THE PROJECT, OR RESULTING FROM DELAYS TO THE PROJECT, INCLUDING BUT NOT LIMITED TO ACCELERATION, CUMULATIVE AFFECT OF THE CHANGE(S), EXPEDITING THE WORK, ETC.

- (f) If the CONTRACTOR should claim that any instruction, request, drawing, specification, action, condition, omission, default, or other situation obligates the DISTRICT to pay additional

00700  
GENERAL CONDITIONS for GENERAL  
CONTRACTOR  
CLOVIS UNIFIED SCHOOL DISTRICT

compensation to CONTRACTOR or to grant an extension of time, or constitutes a waiver of any provision in the Contract Documents, the CONTRACTOR shall provide written "Notice" to the DISTRICT **within five (5) days** after sustaining of such damage, or being notified of an adverse decision, and provide within **fourteen (14) days** of the event the factual basis supporting the claim (unless otherwise specified). The written "Notice" shall state the summary points for which the factual bases will support the claim and cite in detail the Contract Documents (including plans and specifications) upon which the claim is to be based. CONTRACTOR's failure to notify the DISTRICT within such a period shall be deemed a waiver and relinquishment of such a claim. If such notice is given within the specified time, the procedure for its consideration shall be as stated above in these General Conditions. Refer to the Articles entitled, "**DEFINITIONS**," "**CONTRACTOR CLAIMS**," "**DISPUTES - ARCHITECT'S DECISIONS**," "**NOTICE**" and "**WAIVER AND RELEASE FORMS**" for related Contract requirements. The claim, once submitted, shall be a "Certified Claim."

In addition, on or before the end of the month for which the claim has been filed, the CONTRACTOR shall also file with the DISTRICT the **WAIVER AND RELEASE FORMS**, for which the claim and the amount of the claim are identified. If the claim is not indicated on the **WAIVER AND RELEASE FORMS**, CONTRACTOR's claim shall be forfeited and invalidated and it shall not be entitled to consideration for time or payment on account of any such claim.

- (g) If DISTRICT and CONTRACTOR fail to agree to the quantification of costs and/or time to be placed into a Change Order, the DISTRICT at its own discretion may issue a Construction Change Directive (CCD) for those costs and/or time impacts that is deemed appropriate for the changed work conditions. Notwithstanding the lack of agreement upon a Change Order, the CONTRACTOR shall proceed immediately with the changed work upon receipt of a CCD. If CONTRACTOR disputes the CCD, CONTRACTOR may make a claim pursuant to the Article entitled "**DISPUTES**."

#### ARTICLE 60. COMPLETION

- (a) Statutory definitions of "completion" and "complete" shall apply for those statutory purposes. For accrual of liquidated damages, Claim and warranty purposes, "completion" and "complete" mean the point in the Project where (1) Contractor has fully and correctly performed all Work in all parts and requirements, including corrective and punch list work, and (2) DISTRICT's representatives have conducted a final inspection that confirmed this performance. "Substantial" or any other form of partial or non-compliant performance of the Work shall not constitute "completion" or "complete" under the Contract Documents.
- (b) The DISTRICT shall accept completion of the Contract and have the Notice of Completion recorded when the entire Work including CONTRACTOR's punch list(s) and ARCHITECT's final review comments shall have been completed to the satisfaction of the DISTRICT. The Work may only be accepted as complete by action of the DISTRICT's Governing Board.
- (c) However, the DISTRICT, through action by the Governing Board, at its sole option, may accept completion of the Contract and have the Notice of Completion recorded when the entire Work including individual portions of the Work shall have been completed to the satisfaction of the DISTRICT, except for minor corrective and/or incomplete items.
- (d) A final walk through to determine completion of the Contract and to record the Notice of Completion shall occur only upon a valid claim by CONTRACTOR that the Project is complete except for minor corrective and/or incomplete items. Any erroneous claims of completion by CONTRACTOR resulting in a premature walk through shall be at CONTRACTOR's sole cost and expense and DISTRICT shall make adjustments to the contract price by reducing the amount thereof to pay for any costs incurred by the DISTRICT due to the erroneous claims by

00700  
GENERAL CONDITIONS for GENERAL  
CONTRACTOR  
CLOVIS UNIFIED SCHOOL DISTRICT

the CONTRACTOR that the Project is complete. Minor corrective and/or incomplete items shall be identified in the final walk through of the Project.

- (e) If the CONTRACTOR fails to complete the minor corrective and/or incomplete items prior to the expiration of the **thirty-five (35) day** period immediately following recording of the Notice of Completion, the DISTRICT shall withhold from the final payment an amount equal to **150% of the estimated cost**, as determined by the DISTRICT, of each item until such time as the item is completed. At the end of such **thirty-five (35) day** period, if there are items remaining to be corrected and/or completed, the DISTRICT may elect to proceed as provided in the Article entitled "**ARTICLE 64. PAYMENTS WITHHELD.**"
- (f) Regardless of the cause therefore, the CONTRACTOR may not maintain any claim or cause of action against the DISTRICT for damages incurred as a result of its failure or inability to complete its work in a shorter period than established in the Contract Documents, the parties stipulating that the period set forth in the Contract Documents is a reasonable time within which to perform the Work.

**ARTICLE 61. FAILURE TO PERFORM / DELAYED PERFORMANCE OF WORK**

- (a) If CONTRACTOR defaults or neglects to carry out the Work in accordance with the requirements of the Contract Documents, the DISTRICT may, after providing two (2) working days written notice to CONTRACTOR, without prejudice to any other remedy it may have, order the CONTRACTOR to stop the Work or any portion thereof, until the cause for such order has been eliminated. The right of the DISTRICT to stop the Work shall not give rise to a duty on the part of the DISTRICT to exercise this right for the benefit of the CONTRACTOR or any other person or entity. The DISTRICT shall adjust the Contract Sum by reducing the amount thereof by the cost of correcting such deficiencies. If DISTRICT in its sole discretion decides not to correct work not done in accordance with the Contract Documents, it may instead reduce the Contract Sum in an amount commensurate with the damages caused by the deficiencies.
- (b) DISTRICT shall not be liable for any delays or damages related to the time required to obtain government approvals.
- (c) Costs, expenses and damages caused by delays, improperly timed activities, defective construction, or damages to another contractor's work shall be borne by the party responsible. Should CONTRACTOR cause damage to the work or property of any separate contractor, or cause any delay to any such contractor, the CONTRACTOR shall defend, indemnify, and hold DISTRICT harmless for such damage or delay. DISTRICT may backcharge CONTRACTOR for delay or damage to another contractor's work or damage to another contractor's property.

**ARTICLE 62. CORRECTION OF WORK**

- (a) If it is found at any time, before or after completion of the Work, that the CONTRACTOR has varied from the drawings and/or specification and/or Contract Documents, in materials, quality, form or finish, or in the amount of value of the materials and labor used, the ARCHITECT shall make a recommendation:
  - (1) that all such improper work should be removed, remade and replaced, and all work disturbed by these changes be made good at the CONTRACTOR'S expense; ("Option 1"); or
  - (2) that the DISTRICT deduct from any amount due CONTRACTOR, the sum of money equivalent to the difference in value between the work performed and that called for by the drawings and specifications and Contract Documents ("Option2").. ARCHITECT shall determine such difference in value.

00700  
GENERAL CONDITIONS for GENERAL  
CONTRACTOR  
CLOVIS UNIFIED SCHOOL DISTRICT

The DISTRICT may, at its option, choose -either Option 1 or Option 2.

- (b) In the event that the District chooses Option 1, CONTRACTOR shall promptly remove all work identified by DISTRICT as failing to conform to the drawings, specifications, and Contract Documents, whether incorporated or not. CONTRACTOR shall promptly replace and re-execute its own work to comply with the drawings, specifications, and Contract Documents without additional expense to DISTRICT and shall bear the expense of making good all work of other contractors destroyed or damaged by such removal or replacement.
- (c) If CONTRACTOR does not remove such work within a reasonable time, fixed by written notice, DISTRICT may remove it and may store the material at CONTRACTOR'S expense. If CONTRACTOR does not pay expenses of such removal within **ten (10) days'** time thereafter, DISTRICT may, upon **ten (10) days** written notice, deduct the amount of the removal and repair from the Contract amount.

**ARTICLE 63. EXTENSION OF TIME - LIQUIDATED DAMAGES**

- (a) The CONTRACTOR and DISTRICT hereby agree that the exact amount of damages for failure to complete the Work within the time specified is extremely difficult or impossible to determine. CONTRACTOR shall be assessed the sum as set forth in the **Agreement**, as liquidated damages for each and every day the Work required under the Contract Documents remains unfinished past the time for completion, as set forth in the **Agreement**, and any extensions of time granted by the DISTRICT to the CONTRACTOR under the terms of the Contract Documents. The CONTRACTOR will pay to the DISTRICT or DISTRICT may retain from amounts otherwise payable to the CONTRACTOR, said amount for each day after failure to meet the requirements of the contract completion as scheduled in the Agreement. For purposes of this article, the Work shall be considered "complete" in accordance with the provisions of Article entitled "**COMPLETION**," except that the Work may be considered complete without formal acceptance by the DISTRICT Governing Board so long as the Governing Board, at its next regularly scheduled meeting, accepts the Work.
- (b) CONTRACTOR shall not be charged for liquidated damages, as set forth above, because of any delays in completion of Work which are not the fault or negligence of CONTRACTOR, including but not restricted to acts of God as set forth herein. As soon as CONTRACTOR become aware of the delay and no later than **fourteen (14) days** from the commencement of the delay, CONTRACTOR shall notify DISTRICT in writing of causes of delay in accordance with the Contract scheduling specifications. CONTRACTOR shall provide documentation and justification to substantiate the delay and its relation to the Project's critical path. Extension of time shall apply only to that portion of Work affected by the delay, and shall not apply to other portions of Work not so affected.

**ARTICLE 64. PAYMENTS WITHHELD**

- (a) In addition to any amount which DISTRICT may retain under the Article entitled "**COMPLETION**" and the Article entitled "**PAYMENTS**," DISTRICT may withhold a sufficient amount or amounts of any payment or payments otherwise due to CONTRACTOR, as in its judgment may be necessary to cover:
  - (1) Payments which may be past due and payable for just claims against CONTRACTOR or any Subcontractors, or against and about the performance of work on the Project, including, without limitation, payments made pursuant to the Article entitled "**TIMELY PAYMENTS BY CONTRACTOR**."

**00700  
GENERAL CONDITIONS for GENERAL  
CONTRACTOR  
CLOVIS UNIFIED SCHOOL DISTRICT**

- (2) The cost of defective work which CONTRACTOR has not remedied.
- (3) Liquidated damages assessed against CONTRACTOR.
- (4) Penalties for violation of labor laws and/or deficient certified payroll.
- (5) The cost of materials ordered by the DISTRICT pursuant to the Article entitled "MATERIALS AND WORK."
- (6) The cost of completion of the Contract if there exists a reasonable doubt that the Contract can be completed for the balance then unpaid to CONTRACTOR.
- (7) Damage caused by CONTRACTOR to another contractor or Subcontractor.
- (8) Site clean-up as provided in the Article entitled "CLEANING UP."
- (9) Payments to indemnify, defend, or hold harmless the DISTRICT.
- (10) Any payments due to the DISTRICT including but not limited to payments for failed tests, utilities, or imperfections.
- (11) Extra services for ARCHITECT, including but not limited to, services rendered in the evaluation of CONTRACTOR substitution requests, Requests For Information (RFI's), Change Order Requests (COR's) and Claims.
- (12) Extra services for the INSPECTOR including but not limited to re-inspection required due to CONTRACTOR's failed tests or installation of unapproved or defective materials and CONTRACTOR's requests for inspection and CONTRACTOR's failure to attend the inspection.
- (13) Record Documents and other Contract-required documents.
- (14) Submission of daily reports and completeness thereof.
- (15) Breach of any provision of the Contract Documents.
- (16) Stop Payment Notices. For any stop payment notice, the DISTRICT shall withhold the amount stated in the stop payment notice plus an amount to provide for the public entity's reasonable cost of any litigation pursuant to the stop payment notice. For any stop payment notice action the parties resolve before judgment is entered, DISTRICT has the right to permanently withhold for any reasonable cost of litigation for that stop payment notice, even if it exceeds the amount originally withheld by DISTRICT for the estimated reasonable cost of litigation. However, if (1) the CONTRACTOR at its sole expense provides a bond or other security satisfactory to the DISTRICT in the amount of at least one hundred twenty-five percent (125%) of the claim, in a form satisfactory to the DISTRICT, which protects the DISTRICT against such claim, and (2) the DISTRICT chooses to accept the bond, then DISTRICT would release the stop payment notice funds withheld to the CONTRACTOR, except that DISTRICT may permanently withhold for any reasonable cost of litigation. Any stop payment notice release bond shall be executed by a California admitted, fiscally solvent surety, completely unaffiliated with and separate from the surety on the payment and performance bonds, that does not have any assets pooled with the payment and performance bond sureties.

**00700  
GENERAL CONDITIONS for GENERAL  
CONTRACTOR  
CLOVIS UNIFIED SCHOOL DISTRICT**

- (b) If the above grounds are in the opinion of the DISTRICT removed by or at the expense of CONTRACTOR, payment shall be made for amounts withheld because of them.
- (c) DISTRICT may apply such withheld amount or amounts to payment of such claims or obligations at its discretion. In so doing, DISTRICT shall make such payments on behalf of CONTRACTOR. If any payment is so made by DISTRICT, then such amount shall be considered as a payment made under contract by DISTRICT to CONTRACTOR and DISTRICT shall not be liable to CONTRACTOR for such payments made in good faith. Such payments may be made without prior judicial determination of claim or obligations. DISTRICT will render CONTRACTOR an accounting of such funds disbursed on behalf of CONTRACTOR.
- (d) As an alternative to payment of such claims or obligations, DISTRICT, in its sole discretion, may reduce the total contract price or set-off the amount against payments due.

**ARTICLE 65. EXCISE TAXES**

- (a) If under federal excise tax law any transaction hereunder constitutes a sale on which a federal excise tax is imposed and the sale is exempt from such excise tax because it is a sale to a state or local government for its exclusive use, the DISTRICT, upon request, will execute documents necessary to show:
  - (1) that the DISTRICT is a political subdivision of the State for the purposes of such exemption and
  - (2) that the sale is for the exclusive use of the DISTRICT. No excise tax for such materials shall be included in any bid price.

**ARTICLE 66. NO ASSIGNMENT**

- (a) The CONTRACTOR shall not assign, transfer, convey, sublet, or otherwise dispose of the Contract or of its rights, title, or interest in or to the same or any part thereof. If the CONTRACTOR assigns, transfers, conveys, sublets or otherwise disposes of the Contract or its right, title or interest therein, or any part thereof, such attempted or purported assignment, transfer, conveyance, sublease or other disposition shall be null, void and of no legal effect whatsoever; and the Contract may, at the option of the DISTRICT, be terminated, and the DISTRICT shall thereupon be relieved and discharged from any and all liability and obligations growing out of the same to the CONTRACTOR, and to its purported assignee or transferee.

**ARTICLE 67. NOTICE**

- (a) Any notice from one party to the other or otherwise under the Contract shall be in writing and shall be dated and signed by party giving such notice or by a duly authorized representative of such party. Any such notice shall not be effective for any purpose whatsoever unless served in one of the following manners, and copied to the ARCHITECT:
  - (1) If notice is given to DISTRICT, by personal delivery thereof to DISTRICT or by deposit in the United States mail, enclosed in a sealed envelope addressed to DISTRICT, and sent by registered or certified or overnight mail with postage prepaid;
  - (2) If notice is given to CONTRACTOR, by personal delivery thereof to said CONTRACTOR or to CONTRACTOR's superintendent at the site of the Project, or by deposit in the United States mail, enclosed in a sealed envelope addressed to said CONTRACTOR at its regular place of business or at such address as may have been established for the



00700  
GENERAL CONDITIONS for GENERAL  
CONTRACTOR  
CLOVIS UNIFIED SCHOOL DISTRICT

conduct of work under this Agreement, and sent by registered or certified or overnight mail with postage prepaid;

- (3) If notice is given to the surety or other persons, by personal delivery to such surety or other person or by deposit in the United States mail, enclosed in a sealed envelope, addressed to such surety or person at the address of such surety or person last communicated by the surety or other person to the party giving notice, and sent by registered or certified or overnight mail with postage prepaid.

**ARTICLE 68. NO WAIVER**

- (a) The failure of the DISTRICT in any one or more instances to insist upon strict performance of any of the terms of the Contract or to exercise any option herein conferred shall not be construed as a waiver or relinquishment to any extent of the right to assert or rely upon any such terms or option on any future occasion.

**ARTICLE 69. NON-UTILIZATION OF ASBESTOS MATERIAL**

- (a) The CONTRACTOR will be required to execute and submit a Certificate regarding Non-Asbestos Containing Materials.
- (b) Should asbestos containing materials be installed by the CONTRACTOR in violation of this certification, or if removal of asbestos containing materials is part of the Project, decontamination and removal will meet the following criteria:
  - (1) Decontamination and removal of work found to contain asbestos or work installed with asbestos containing equipment shall be done only under the supervision of a qualified consultant, knowledgeable in the field of asbestos abatement and accredited by the Environmental Protection Agency (EPA).
  - (2) The asbestos removal CONTRACTOR shall be an EPA accredited CONTRACTOR qualified in the removal of asbestos and shall be chosen and approved by the asbestos consultant who shall have sole discretion and final determination in this matter.
  - (3) The asbestos consultant shall be chosen and approved by the DISTRICT who shall have sole discretion and final determination in this matter.
  - (4) The work will not be accepted until asbestos contamination is reduced to levels deemed acceptable by the asbestos consultant.
- (c) Cost of all asbestos removal, including, but not necessarily limited to the cost of the asbestos removal CONTRACTOR, the cost of the asbestos consultant, analytical and laboratory fees, time delays and additional costs as may be incurred by the DISTRICT shall be borne entirely by the CONTRACTOR.
- (d) Hold Harmless: Interface of Work for the Project with work containing asbestos shall be executed by the CONTRACTOR at his/her risk and at his/her discretion with full knowledge of the currently accepted standards, hazards, risks and liabilities associated with asbestos work and asbestos containing products. By execution of the Agreement, the CONTRACTOR acknowledges the above and agrees to hold harmless the DISTRICT, its Governing Board, employees, agents, and ARCHITECT and assigns for all asbestos liability which may be associated with this work. The CONTRACTOR further agrees to instruct its employees with respect to the above mentioned standards, hazards, risks and liabilities.

**00700  
GENERAL CONDITIONS for GENERAL  
CONTRACTOR  
CLOVIS UNIFIED SCHOOL DISTRICT**

**ARTICLE 70. STUDENT SAFETY ALLOWANCES**

- (a) Requirements for Contact with Students: Contractor shall comply with Education Code section 45125.2 and this Article. If Contractor's employee(s), agent(s) or subcontractor(s) will have more than limited contact with students, then Contractor must take one or more of the following steps:
  - (1) Install a physical barrier at the worksite to limit contact with pupils.
  - (2) Have an employee, who the Department of Justice has ascertained has not been convicted of a violent or serious felony, continually monitor and supervise employees. The entity shall verify in the Independent Contractor Student Contact Form to the DISTRICT that the employee charged with monitoring and supervising its employees has no such convictions.
  - (3) Arrange for surveillance by personnel with DISTRICT approval.
- (b) If CONTRACTOR is providing the services in an emergency or exceptional situation, CONTRACTOR is not required to comply with Education Code section 45125.2. An "emergency or exceptional" situation is one in which pupil health or safety is endangered or when repairs are needed to make a facility safe and habitable. DISTRICT shall determine whether an emergency or exceptional situation exists.
- (c) DISTRICT Processing to Department of Justice: If Contractor is required to receive verification for an employee, agent or subcontractor from the Department of Justice pursuant to this Article or the Education Code, the DISTRICT may, at its sole discretion, assist Contractor by processing Contractor's request to the Department of Justice using the DISTRICT's fingerprinting hardware and materials. The DISTRICT will charge for such assistance at its standard rates charged to its own employees.
- (d) Verification of Compliance Under Penalty of Perjury: Contractor shall certify under penalty of perjury, on a form provided by the DISTRICT, compliance with this Article prior to performing any work in which any employee, agent or subcontractor will have more than limited contact with students.
- (e) Indemnification and Hold Harmless Agreement: It shall be Contractor's sole responsibility to ensure compliance with Education Code sections 45125.1 and 45125.2 and this Article. In addition to and without limiting any other indemnity promise made in this contract, Contractor agrees to defend, indemnify and hold harmless the DISTRICT for and from any and all actual or potential claims of any kind or description seeking to hold the DISTRICT, its employees or its agents responsible for violation of Education Code sections 45125.1 or 45125.2, or any other violation arising out of duties imposed by Education Code sections 45125.1 or 45125.2, arising out of Contractor's employee's, agent's or subcontractor's contact with students. Contractor's indemnification obligation shall include, without limitation, judgments, settlements, contributions, payments, fines and penalties, as well as the costs of investigating and complying with equitable decrees or governmental directives. The defense obligation shall include, without limitation, legal fees, litigation expenses, and investigative costs.
- (f) Definitions:
  - (1) A "violent felony" is any felony listed in subdivision (c) of section 667.5 of the Penal Code.
  - (2) A "serious felony" is any felony listed in subdivision (c) of section 1192.7 of the Penal Code.

00700  
GENERAL CONDITIONS for GENERAL  
CONTRACTOR  
CLOVIS UNIFIED SCHOOL DISTRICT

- (3) An "emergency or exceptional situation" is, as determined by the DISTRICT in its sole discretion, a situation in which pupil health or safety is endangered or when repairs are needed to make a school facility safe and habitable.

**ARTICLE 71. ALLOWANCES**

- (a) The following costs shall be included in all allowances;
- (1) Cost of the product to CONTRACTOR or Subcontractor, less applicable trade discounts
  - (2) Delivery to the site
  - (3) Applicable taxes
- (b) CONTRACTOR costs included in the Contract Sum include, but are not limited to;
- (1) Arrangement of product(s) shipping and handling at site, including unloading, uncrating, and storage.
  - (2) Protection of products from the elements and from damage
  - (3) Labor for installation, adjustments and finishing products
  - (4) Product warranties
  - (5) Scheduling changes and updates
  - (6) Other expenses required to complete installation
  - (7) CONTRACTOR and Subcontractor(s) overhead and profit
- (c) The adjustments in costs will be made if the net cost is more or less than the specified amount of the allowance. The net cost of the adjustment shall be the amount of the difference between the specified allowance and the actual cost of the material, with the exception of a not-to-exceed 15% mark-up for overhead and profit. The Contract Sum will be adjusted by Change Order.
- (1) Submit any claims for anticipated additional costs, or other expenses caused by the selection the allowance, prior to execution of the work.
  - (2) Submit documentation for actual additional costs, or other expenses caused by the selection the allowance, prior to execution of the work.
  - (3) Failure to submit claims within the designated time will constitute a waiver of claims for additional costs.
- (d) DISTRICT will separately bid the materials, subject to the specified allowances. The successful bidder will be assigned to CONTRACTOR, and shall be considered a Subcontractor to the CONTRACTOR. Upon assignment, the CONTRACTOR shall all make the necessary submittals, prepare necessary shop drawings, and coordinate all related work. CONTRACTOR shall make all necessary adjustments and revisions to the Project Schedule for such allowances and Subcontractor assignments.

**ARTICLE 72. WAIVER AND RELEASE FORMS**

- (a) Commensurate with the statutes of Public Contract Code section 7100, provisions in public works contracts with public entities which provide that acceptance of a payment otherwise due a CONTRACTOR is a waiver of all claims against the public entity arising out of the Work performed under the Contract or which condition the right to payment upon submission of a release by the CONTRACTOR of all claims against the public entity arising out of performance of the public work are against public policy and null and void. This section shall not prohibit a public entity from placing in a public works contract and enforcing a contract provision which provides that payment of undisputed contract amounts is contingent upon the CONTRACTOR furnishing the public entity with a release of all claims against the public entity arising by virtue of the public works contract related to those amounts. Disputed claims in stated amount may be

00700  
GENERAL CONDITIONS for GENERAL  
CONTRACTOR  
CLOVIS UNIFIED SCHOOL DISTRICT

specifically excluded by the CONTRACTOR from the operation of the release.

- (b) Neither the OWNER nor original CONTRACTOR by any term of their contract, or otherwise, shall waive, affect, or impair the claims and liens of other persons whether with or without notice except by their written consent, and any term of the contract to that effect shall be null and void. Any written consent given by any claimant pursuant to this subdivision shall be null, void, and unenforceable unless and until the claimant executes and delivers a waiver and release. Such a waiver and release shall be binding and effective to release the OWNER, construction lender, and surety on a payment bond from claims and liens only if the waiver and release follows substantially one of the forms set forth in this section and is signed by the claimant or his or her authorized agent, and, in the case of a **conditional release**, there is evidence of payment to the claimant. Evidence of payment may be by the claimant's endorsement on a single or joint payee check that has been paid by the bank upon which it was drawn or by written acknowledgment of payment given by the claimant.
- (c) No oral or written statement purporting to waive, release, impair or otherwise adversely affect a claim is enforceable or creates any estoppel or impairment of a claim unless:
  - (1) It is pursuant to a waiver and release prescribed herein, or
  - (2) the claimant had actually received payment in full for the claim.
- (d) This section does not affect the enforceability of either an accord and satisfaction regarding a bona fide dispute or any agreement made in settlement of an action pending in any court provided the accord and satisfaction or agreement and settlement make specific reference to the, stop notice, or bond claims.
- (e) The waiver and release given by any claimant hereunder shall be null, void, and unenforceable unless it follows the text of the following forms in the appropriate circumstances. Each waiver form shall be printed in type equal in size or larger than the largest type on other documents signed by the claimant.
- (e1) Where the claimant is required to execute a waiver and release in exchange for, or in order to induce the payment of, a progress payment and the claimant is not, in fact, paid in exchange for the waiver and release or a single payee check or joint payee check is given in exchange for the waiver and release, the waiver and release shall follow the following form:

00700  
GENERAL CONDITIONS for GENERAL  
CONTRACTOR  
CLOVIS UNIFIED SCHOOL DISTRICT

**CONDITIONAL WAIVER AND RELEASE UPON "PROGRESS PAYMENT"**

Upon receipt by the undersigned of a check from: \_\_\_\_\_  
(Maker of Check)

in the sum of: \$ \_\_\_\_\_ payable to: \_\_\_\_\_  
(Amount of Check) (Payee or Payees of Check)

and when the check has been properly endorsed and has been paid by the bank upon which it is drawn, this document shall become effective to release any mechanic's lien, stop notice, or bond right the undersigned has on the job of

\_\_\_\_\_ located at: \_\_\_\_\_  
(OWNER) (Job Description)

to the following extent. This release covers a progress payment for labor, services, equipment, or material furnished to

\_\_\_\_\_ through: \_\_\_\_\_  
(Your Customer) (Date)

only and does not cover any retentions retained before or after the release date; extras furnished before the release date for which payment has not been received; extras or items furnished after the release date. Rights based upon work performed or items furnished under a written change order which has been fully executed by the parties prior to the release date are covered by this release unless specifically reserved by the claimant in this release. This release of any mechanic's lien, stop notice, or bond right shall not otherwise affect the contract rights, including rights between parties to the contract based upon a rescission, abandonment, or breach of the contract, or the right of the undersigned to recover compensation for furnished labor, services, equipment, or material covered by this release if that furnished labor, services, equipment, or material was not compensated by the progress payment. Before any recipient of the document relies on it, said party should verify evidence of payment to the undersigned.

\_\_\_\_\_ (Company Name) \_\_\_\_\_ (Date)

By: \_\_\_\_\_  
(Title)

**Exclusions:** Listing of Claims, of which Notice has been given:

1. Claim for: \_\_\_\_\_ In the amount of: \$ \_\_\_\_\_
2. Claim for: \_\_\_\_\_ In the amount of: \$ \_\_\_\_\_
3. Claim for: \_\_\_\_\_ In the amount of: \$ \_\_\_\_\_
4. Claim for: \_\_\_\_\_ In the amount of: \$ \_\_\_\_\_
5. Claim for: \_\_\_\_\_ In the amount of: \$ \_\_\_\_\_

(e2) Where the claimant is required to execute a waiver and release in exchange for, or in order to induce payment of, a progress payment and the claimant asserts in the waiver it has, in fact,

**00700  
GENERAL CONDITIONS for GENERAL  
CONTRACTOR  
CLOVIS UNIFIED SCHOOL DISTRICT**

been paid the progress payment, the waiver and release shall follow the following form:

00700  
GENERAL CONDITIONS for GENERAL  
CONTRACTOR  
CLOVIS UNIFIED SCHOOL DISTRICT

**UNCONDITIONAL WAIVER AND RELEASE UPON "PROGRESS PAYMENT"**

The undersigned has been paid and has received a progress payment in the sum of \$ \_\_\_\_\_ for labor, services, equipment, or material furnished to

\_\_\_\_\_  
(Your Customer)

on the job of: \_\_\_\_\_ located at: \_\_\_\_\_  
(OWNER) (Job Description)

and does hereby release any mechanic's lien, stop notice, or bond right that the undersigned has on the above referenced job to the following extent. This release covers a progress payment for labor, services, equipment, or materials furnished to

\_\_\_\_\_ through: \_\_\_\_\_  
(Your Customer) (Date)

only and does not cover any retentions retained before or after the release date; extras furnished before the release date for which payment has not been received; extras or items furnished after the release date. Rights based upon work performed or items furnished under a written change order which has been fully executed by the parties prior to the release date are covered by this release unless specifically reserved by the claimant in this release. This release of any mechanic's lien, stop notice, or bond right shall not otherwise affect the contract rights, including rights between parties to the contract based upon a rescission, abandonment, or breach of the contract, or the right of the undersigned to recover compensation for furnished labor, services, equipment, or material covered by this release if that furnished labor, services, equipment, or material was not compensated by the progress payment.

\_\_\_\_\_  
(Company Name) (Date)

By: \_\_\_\_\_  
(Title)

**Exclusions:** Listing of Claims, of which Notice has been given:

- |                     |                            |
|---------------------|----------------------------|
| 1. Claim for: _____ | In the amount of: \$ _____ |
| 2. Claim for: _____ | In the amount of: \$ _____ |
| 3. Claim for: _____ | In the amount of: \$ _____ |
| 4. Claim for: _____ | In the amount of: \$ _____ |
| 5. Claim for: _____ | In the amount of: \$ _____ |

"NOTICE: THIS DOCUMENT WAIVES RIGHTS UNCONDITIONALLY AND STATES THAT YOU HAVE BEEN PAID FOR GIVING UP THOSE RIGHTS. THIS DOCUMENT IS ENFORCEABLE AGAINST YOU IF YOU SIGN IT, EVEN IF YOU HAVE NOT BEEN PAID. IF YOU HAVE NOT BEEN PAID, USE A CONDITIONAL RELEASE FORM."

00700  
GENERAL CONDITIONS for GENERAL  
CONTRACTOR  
CLOVIS UNIFIED SCHOOL DISTRICT

- (e3) Where the claimant is required to execute a waiver and release in exchange for, or in order to induce the payment of, a final payment and the claimant is not, in fact, paid in exchange for the waiver and release or a single payee check or joint payee check is given in exchange for the waiver and release, the waiver and release shall follow the following form:

**CONDITIONAL WAIVER AND RELEASE UPON "FINAL PAYMENT"**

Upon receipt by the undersigned of a check from \_\_\_\_\_  
in the sum of \$ \_\_\_\_\_ payable to: \_\_\_\_\_

and when the check has been properly endorsed and has been paid by the bank upon which it is drawn, this document shall become effective to release any mechanic's lien, stop notice, or bond right the undersigned has on the job of

\_\_\_\_\_ located at: \_\_\_\_\_  
(OWNER) (Job Description)

This release covers the final payment to the undersigned for all labor, services, equipment, or material furnished on the job, except for disputed claims for additional work in the amount of \$ \_\_\_\_\_

Before any recipient of this document relies on it, the party should verify evidence of payment to the undersigned.

\_\_\_\_\_ (Company Name) \_\_\_\_\_ (Date)

By: \_\_\_\_\_  
(Title)

**Exclusions:** Listing of Claims, of which Notice has been given:

- |                     |                            |
|---------------------|----------------------------|
| 1. Claim for: _____ | In the amount of: \$ _____ |
| 2. Claim for: _____ | In the amount of: \$ _____ |
| 3. Claim for: _____ | In the amount of: \$ _____ |
| 4. Claim for: _____ | In the amount of: \$ _____ |
| 5. Claim for: _____ | In the amount of: \$ _____ |

- (e4) Where the claimant is required to execute a waiver and release in exchange for, or in order to induce payment of, a final payment and the claimant asserts in the waiver it has, in fact, been paid the final payment, the waiver and release shall follow the following form:

**UNCONDITIONAL WAIVER AND RELEASE UPON "FINAL PAYMENT"**

The undersigned has been paid in full for all labor, services, equipment or material

furnished to: \_\_\_\_\_  
(Your Customer)



**00700**  
**GENERAL CONDITIONS for GENERAL**  
**CONTRACTOR**  
**CLOVIS UNIFIED SCHOOL DISTRICT**

on the job of: \_\_\_\_\_  
(OWNER)

located at: \_\_\_\_\_  
(Job Description)

00700  
GENERAL CONDITIONS for GENERAL  
CONTRACTOR  
CLOVIS UNIFIED SCHOOL DISTRICT

and does hereby waive and release any right to a mechanic's lien, stop notice, or any right against a labor and material bond on the job, except for disputed claims for extra work in the amount of \$\_\_\_\_\_.

\_\_\_\_\_  
(Company Name) (Date)

By: \_\_\_\_\_  
(Title)

**Exclusions:** Listing of Claims, of which Notice has been given:

- |                     |                            |
|---------------------|----------------------------|
| 1. Claim for: _____ | In the amount of: \$ _____ |
| 2. Claim for: _____ | In the amount of: \$ _____ |
| 3. Claim for: _____ | In the amount of: \$ _____ |
| 4. Claim for: _____ | In the amount of: \$ _____ |
| 5. Claim for: _____ | In the amount of: \$ _____ |

"NOTICE: THIS DOCUMENT WAIVES RIGHTS UNCONDITIONALLY AND STATES THAT YOU HAVE BEEN PAID FOR GIVING UP THOSE RIGHTS. THIS DOCUMENT IS ENFORCEABLE AGAINST YOU IF YOU SIGN IT, EVEN IF YOU HAVE NOT BEEN PAID. IF YOU HAVE NOT BEEN PAID, USE A CONDITIONAL RELEASE FORM."

**ARTICLE 73. INDEMNIFICATION**

(a) Scope: Contractor

(To the fullest extent permitted by law, CONTRACTOR shall defend, indemnify, and hold harmless the DISTRICT, ARCHITECT, ARCHITECT's consultants, the Project Inspector, the State of California, and their respective agents, employees, officers, volunteers, Boards of Trustees, members of the Boards of Trustees, and directors, from and against claims, damages, losses, and expenses (including, but not limited to attorneys' fees and costs including fees of consultants) arising out of or resulting from: performance of the Work (including, but not limited to) the CONTRACTOR's or its Subcontractors' use of the site; the CONTRACTOR's or its Subcontractors' construction of the Work or failure to construct the Work, or any portion thereof; the use, misuse, erection, maintenance, operation, or failure of any machinery or equipment, including but not limited to scaffolds, derricks, ladders, hoists, and rigging supports, whether or not such machinery or equipment was furnished, rented, or loaned by any of the indemnitees; or any act, omission, negligence, or willful misconduct of the CONTRACTOR or its Subcontractors or their respective agents, employees, material or equipment suppliers, invitees, or licensees but only to the extent caused in whole or in part by the acts or omissions of the CONTRACTOR, its Subcontractors, anyone directly or indirectly employed by any of them, or anyone for whose acts they may be liable, regardless of whether or not such claim, damage, loss, or expense is caused in part by a party identified hereunder. Such obligation shall not be construed to negate, abridge, or reduce other rights or obligations of indemnity, which would otherwise exist as to a party, person, or entity described in this paragraph.

(b) Scope: Subcontractors

To the fullest extent permitted by law, the Subcontractors shall defend, indemnify, and hold harmless the DISTRICT, ARCHITECT, ARCHITECT's consultants, the Project Inspector, the State of California, and their respective agents, employees, officers, volunteers, Boards of

**00700**  
**GENERAL CONDITIONS for GENERAL**  
**CONTRACTOR**  
**CLOVIS UNIFIED SCHOOL DISTRICT**

Trustees, members of the Boards of Trustees, and directors, from and against claims, damages, losses, and expenses (including, but not limited to attorneys' fees and costs including fees of consultants) arising out of or resulting from: performance of the Work (including, but not limited to) the Subcontractors' use of the site; the Subcontractors' construction of the Work or failure to construct the Work, or any portion thereof; the use, misuse, erection, maintenance, operation, or failure of any machinery or equipment, including but not limited to scaffolds, derricks, ladders, hoists, and rigging supports, whether or not such machinery or equipment was furnished, rented, or loaned by any of the indemnitees; or any act, omission, negligence, or willful misconduct of the Subcontractors or their respective agents, employees, material or equipment suppliers, invitees, or licensees but only to the extent caused in whole or in part by the acts or omissions of the Subcontractors, anyone directly or indirectly employed by any of them, or anyone for whose acts they may be liable, regardless of whether or not such claim, damage, loss, or expense is caused in part by a party identified hereunder. Such obligation shall not be construed to negate, abridge, or reduce other rights or obligations of indemnity, which would otherwise exist as to a party, person, or entity described in this paragraph.

(c) **Joint and Several Liability**

In the event more than one Subcontractor is connected with an accident or occurrence covered by this indemnification, then all such Subcontractors shall be jointly and severally responsible to each of the indemnitees for indemnification, and the ultimate responsibility among such indemnifying Subcontractors for the loss and expense of any such indemnification shall be resolved without jeopardy to any indemnitee. The provisions of the indemnity provided for herein shall not be construed to indemnify any Indemnitee for its own negligence if not permitted by law or to eliminate or reduce any other indemnification or right which any indemnitee has by law or equity.

(d) **No Limitation**

The CONTRACTOR's and the Subcontractors' obligation to indemnify and defend the indemnitees hereunder shall include, without limitation, any and all claims, damages, and costs: for injury to persons and property (including loss of use), and sickness, disease or death of any person; for breach of any warranty, express or implied; for failure of the CONTRACTOR or a Subcontractor to comply with any applicable governmental law, rule, regulation, or other requirement; and for products installed in or used in connection with the Work.

**ARTICLE 74. GOVERNING LAW AND VENUE**

- (a) The Contract Documents shall be governed by the law of the State of California. Venue for an actions concerning or arising out of the Contract Documents or the Work shall be in Superior Court of the State of California in and for the County of Fresno.

**ARTICLE 75. TERMINATION BY DISTRICT FOR CONVENIENCE**

- (a) DISTRICT may, at any time, terminate the Contract for the DISTRICT'S convenience and without cause.
- (b) Upon receipt of written notice from the DISTRICT of such termination for the DISTRICT's convenience, CONTRACTOR shall:
- (1) Cease operations as directed by the DISTRICT in the notice;
  - (2) Take actions necessary, or that the DISTRICT may direct, for the protection and preservation of the Work; and

**00700  
GENERAL CONDITIONS for GENERAL  
CONTRACTOR  
CLOVIS UNIFIED SCHOOL DISTRICT**

- (3) Except for work directed to be performed prior to the effective date of termination stated in the notice, terminate all existing subcontracts and purchase orders and enter into no further subcontracts and purchase orders.
- (c) In case of such termination for the DISTRICT's convenience, the CONTRACTOR shall be entitled to receive payment for work executed, and costs incurred by reason of such termination, along with reasonable overhead and profit on the work not executed.

**ARTICLE 76. MUTUAL TERMINATION FOR CONVENIENCE**

- (a) The CONTRACTOR and the DISTRICT may mutually agree in writing to terminate the Contract for convenience. The CONTRACTOR shall receive payment for all Work performed to the date of termination.
- (b) The CONTRACTOR may terminate the Contract if the Work is stopped for a period of thirty (30) consecutive days through no act or fault of the CONTRACTOR, a Subcontractor, a Sub-subcontractor, their agents, or employees, or any other persons performing portions of the Work for whom the CONTRACTOR is contractually responsible, for only the following reasons:
  - (1) issuance of an order of a court or other public authority having jurisdiction which requires all work to be stopped;
  - (2) an act of government, such as a declaration of national emergency, making material unavailable which requires all work to be stopped;
  - (3) if repeated suspensions, delays, or interruptions by the DISTRICT constitute in the aggregate more than 100 percent (100%) of the total number of days scheduled for completion, or one hundred twenty (120) days in any three hundred sixty-five (365) day period, whichever is less.

If one of the above reasons exists, the CONTRACTOR may, upon written notice of seven (7) additional days to the DISTRICT, terminate the Contract and recover from the DISTRICT payment for work executed and for reasonable costs verified by the Architect with respect to materials, equipment, tools, construction equipment, and machinery, including reasonable overhead, profit, and damages.

If the Work is stopped for a period of sixty (60) consecutive days through no act or fault of the CONTRACTOR, Subcontractor, Sub-Subcontractor, their agents or employees, or any other persons performing portions of the Work for whom the CONTRACTOR is contractually responsible because the DISTRICT has persistently failed to fulfill the DISTRICT's obligations under the Contract Documents with respect to matters essential to the progress of the Work, the CONTRACTOR may, upon written notice of seven (7) additional days to the DISTRICT, terminate the Contract and recover from the DISTRICT payment for work executed and for reasonable costs verified by the Architect with respect to materials, equipment, tools, construction equipment, and machinery, including reasonable overhead, profit, and damages.

- (c) The DISTRICT may terminate the Contract if the CONTRACTOR:
  - (1) refuses or fails to supply enough properly skilled workers or proper materials;
  - (2) fails to make payment to Subcontractors for materials or labor in accordance with Business and Professions Code section 7108.5;

00700  
GENERAL CONDITIONS for GENERAL  
CONTRACTOR  
CLOVIS UNIFIED SCHOOL DISTRICT

- (3) disregards laws, ordinances, rules, regulations, or orders of a public authority having jurisdiction; or
  - (4) otherwise is in substantial breach of a provision of the Contract Documents.
- (d) When any of the above reasons exist, the DISTRICT may, without prejudice to any other rights or remedies of the DISTRICT and after giving the CONTRACTOR and the CONTRACTOR's surety, if any, written notice of seven (7) days, terminate the Contract and may, subject to any prior rights of the surety:
- (1) take possession of the site and of all material, equipment, tools, and construction equipment, and machinery thereon owned by the CONTRACTOR;
  - (2) accept assignment of subcontracts; and
  - (3) complete the Work by whatever reasonable method the DISTRICT may deem expedient.

If the DISTRICT terminates the Contract for one of the reasons stated above, the CONTRACTOR shall not be entitled to receive further payment until the Work is complete.

- (e) If the unpaid balance of the Contract Sum exceeds costs of completing the Work, including compensation for professional services and expenses made necessary thereby, such excess shall be paid to the CONTRACTOR. If such costs exceed the unpaid balance, the CONTRACTOR shall pay the difference to the DISTRICT. The amount to be paid to the CONTRACTOR, or DISTRICT, as the case may be, shall be certified by the Architect upon application. This payment obligation shall survive completion of the Work.

J:\wdocs\00021\247\agt\00624844.DOCX

**PAYMENT BOND  
(Labor and Material)**

**KNOW ALL MEN BY THESE PRESENTS:**

That **WHEREAS,**

---

and

Hereinafter designated as the "Principal", have entered into a contract for the furnishing of all materials and labor, services and transportation, necessary, convenient, and proper to construct

**BID # 2848  
Paving at Various Sites**

Which said agreement dated \_\_\_\_\_, 20\_\_\_\_, and all of the contract documents attached to or forming a part of said agreement, are hereby referred to and made a part hereof; and

WHEREAS, the Principal is required, before entering upon the performance of the work, to file a good and sufficient bond with the body by whom the contract is awarded to secure the claims arising under said agreement.

**NOW, THEREFORE, THESE PRESENTS WITNESSETH:**

That the said Principal and the undersigned

---

are held and firmly bound unto all laborers, material men, and other persons referred to in said statutes in the sum of \_\_\_\_\_ Dollars (\$ \_\_\_\_\_ ) which sum well and truly be made, we bind ourselves, our heirs, executors, administrators, successors, or assigns, jointly and severally, by these presents.

The condition of this obligation is that if the said Principal or any of its subcontractors, or the heirs, executors, administrators, successors, or assigns of any, all, or either of them, shall fail to pay for any materials, provisions, provender or other supplies, or teams, used in, upon, for, or about the performance of the work contracted to be done, or for any work or labor thereon of any kind or for amounts due under the Unemployment Insurance Act with respect to such work or labor, that said Surety will pay the same in an amount not exceeding the amount hereinabove set forth, and also in case suit is brought upon this bond, will pay a reasonable attorney's fee to be awarded and fixed by the Court, and to be taxed as costs and to be included in the judgment therein rendered.

It is hereby expressly stipulated and agreed that this bond shall inure to the benefit of any and all persons, companies, and corporations entitled to file claims so as to give a right of action to them or their assigns in any suit brought upon this bond.

Should the condition of this bond be fully performed, then this obligation shall become null and void, otherwise it shall be and remain in full force and effect.



**PERFORMANCE BOND**

**KNOW ALL MEN BY THESE PRESENTS** that we

\_\_\_\_\_ as Principal, and \_\_\_\_\_ as Surety, are held and firmly bound unto **Clovis Unified School District**, in the County of Fresno, State of California, hereinafter called the "Owner", acting on behalf of the State Allocation Board, State of California, in the sum of \_\_\_\_\_ **Dollars (\$ \_\_\_\_\_ )** for the payment of which sum well and truly made, we bind ourselves, our heirs, executors, administrators, and successors, jointly and severally, firmly by these presents.

The condition of this obligation is such, that whereas the Principal entered into a certain contract with the Owner, dated \_\_\_\_\_, 20\_\_\_\_ for construction of

**BID #2848  
Paving at Various Sites**

**NOW, THEREFORE**, if the Principal shall well and truly perform and fulfill all the undertakings, covenants, terms, conditions, and agreements of said contract during the original term of said contract and any extensions thereof that may be granted by the Owner, with or without notice to the Surety, and during the life of any guaranty required under the contract, and shall also well and truly perform and fulfill all the undertakings, covenants, terms, conditions, and agreements of any and all duly authorized modifications of said contract that may hereafter be made, then this obligation to be void, otherwise to remain in full force and virtue.

And the said Surety, for value received, hereby stipulates and agrees that no change, extension of time, alteration or addition to the terms of the contract or to the work to be performed thereunder or the specifications accompanying the same, shall in any way affect its obligation on this bond, and it does hereby waive notice of any such change, extension of time, alteration or addition to the terms of the contract, or to the work, or to the specifications.

**IN WITNESS WHEREOF**, the above-bounden parties have executed this instrument under their several seals this \_\_\_\_\_ day of \_\_\_\_\_, 20\_\_\_\_ hereto affixed and these presents duly signed by its undersigned representative, pursuant to authority of its governing body.

(To be signed by \_\_\_\_\_ )  
(Principal and Surety, \_\_\_\_\_ )  
(and acknowledged and \_\_\_\_\_ )  
(Notarial Seal attached \_\_\_\_\_ )

(Affix Corporate Seal)

(Individual Principal)

(Business Address)



(Affix Corporate Seal)

(Corporate Principal)

(Business Address)

(Affix Corporate Seal)

(Corporate Surety)

(Business Address)

By:

The rate or premium on this bond is \_\_\_\_\_ per thousand.

The total amount of premium charged is \_\_\_\_\_.

The above must be filled in by Corporate Surety.

END OF SECTION  
3.97 (8.98)