



PROJECT:

Online School & Special Education
Administration District Office Expansion
Clovis, CA

Date : 10/26/23

TETER Project No.: 12242

CLIENT:

Clovis Unified School District
1450 Herndon Ave.
Clovis, CA 93611

District Bid Number.: 2965

DSA File No.: n/a

DSA Appl. No.: 02-120813

The following additions, deletions and revisions to the plans, specifications and Addenda shall become a part of the plans and specifications. It is the responsibility of the General Contractor to submit the information contained in this addendum to all subcontractors and suppliers. The Bidder shall acknowledge receipt of the Addendum in the Bid Proposal. (Addendum number of pages: 8 pages + 73 attachments = 557 total pages).

PROJECT MANUAL:

5 – 01: PROJECT MANUAL, - 08 41 13 “ALUMINUM – FRAMED ENTRANCES AND STOREFRONT”, revise as follows:

- A. PART 2 – PRODUCTS, add the following
 - a. INTERIOR DOOR SYSTEM
 - i. Basis of Design: Kawneer 500 – Wide Stile design.

5 – 02: PROJECT MANUAL, - 10 22 38 “OPERABLE PANEL PARTITIONS”, revise as follows:

- A. Eliminate reference to “Buy American certificate” from section 1.6 item F.

5 – 03: PROJECT MANUAL, - 11 52 13 “PROJECTION SCREENS”, revise as follows:

- B. Replace section 11 52 13 in its entirety with section 11 52 13 attached. (5 pages)





5 – 04: PROJECT MANUAL, - “APPENDIX”, revise as follows:

- A. Replace “SUMMARY OF WORK”, in its entirety with “SUMMARY OF WORK”, attached. (52 pages)
- B. Replace “CONSTRUCTION SCHEDULE”, in its entirety with “CONSTRUCTION SCHEDULE”, attached. (8 pages)
- C. Replace “SITE LOGISTIN PLAN LENEND – AD4-CM01”, in its entirety with “SITE LOGISTIN PLAN LENEND – AD5-CM01”, attached. (1 page)
- D. Add “STORMWATER POLLUTION PREVENTION PLAN” to the project manual appendix. (414 pages)
- E. Add “RFI LOG’ to the project manual appendix. (7 pages)

DRAWINGS:

- 5 – 05: DRAWINGS, SHEET C1.1 - “PARTIAL TOPOGRAPHIC SURVEY”,** revise as follows:
A. Replace drawing C1.1 in its entirety with drawing C1.1 attached. (1 page)
- 5 – 06: DRAWINGS, SHEET C1.2 - “PARTIAL TOPOGRAPHIC SURVEY”,** revise as follows:
A. Replace drawing C1.2 in its entirety with drawing C1.2 attached. (1 page)
- 5 – 07: DRAWINGS, SHEET C1.3 - “PARTIAL TOPOGRAPHIC SURVEY”,** revise as follows:
A. Replace drawing C1.3 in its entirety with drawing C1.3 attached. (1 page)
- 5 – 08: DRAWINGS, SHEET C2.1 - “PARTIAL DEMOLITION PLAN”,** revise as follows:
A. Replace drawing C2.1 in its entirety with drawing C2.1 attached. (1 page)
- 5 – 09: DRAWINGS, SHEET C2.2 - “PARTIAL DEMOLITION PLAN”,** revise as follows:
A. Replace drawing C2.2 in its entirety with drawing C2.2 attached. (1 page)
- 5 – 10: DRAWINGS, SHEET C3.1 - “PARTIAL SITE PLAN”,** revise as follows:
A. Replace drawing C3.1 in its entirety with drawing C3.1 attached. (1 page)
- 5 – 11: DRAWINGS, SHEET C3.2 - “PARTIAL SITE PLAN”,** revise as follows:
A. Replace drawing C3.2 in its entirety with drawing C3.2 attached. (1 page)
- 5 – 12: DRAWINGS, SHEET C3.3 - “PARTIAL SITE PLAN”,** revise as follows:
A. Replace drawing C3.3 in its entirety with drawing C3.3 attached. (1 page)
- 5 – 13: DRAWINGS, SHEET C4.1 - “PARTIAL HORIZONTAL CONTROL PLAN”,** revise as follows:
A. Replace drawing C4.1 in its entirety with drawing C4.1 attached. (1 page)
- 5 – 14: DRAWINGS, SHEET C4.2 - “PARTIAL HORIZONTAL CONTROL PLAN”,** revise as follows:
A. Replace drawing C4.2 in its entirety with drawing C4.2 attached. (1 page)
- 5 – 15: DRAWINGS, SHEET C4.3 - “PARTIAL HORIZONTAL CONTROL PLAN”,** revise as follows:
A. Replace drawing C4.3 in its entirety with drawing C4.3 attached. (1 page)
- 5 – 16: DRAWINGS, SHEET C4.5 - “PARTIAL HORIZONTAL CONTROL PLAN”,** revise as follows:
A. Replace drawing C4.5 in its entirety with drawing C4.5 attached. (1 page)

- 5 – 17: DRAWINGS, SHEET C5.1 - “PARTIAL GRADING AND DRAINAGE PLAN”**, revise as follows:
- A. Replace drawing C5.1 in its entirety with drawing C5.1 attached. (1 page)
- 5 – 18: DRAWINGS, SHEET C5.2 - “PARTIAL GRADING AND DRAINAGE PLAN”**, revise as follows:
- A. Replace drawing C5.2 in its entirety with drawing C5.2 attached. (1 page)
- 5 – 19: DRAWINGS, SHEET C5.3 - “PARTIAL GRADING AND DRAINAGE PLAN”**, revise as follows:
- A. Replace drawing C5.3 in its entirety with drawing C5.3 attached. (1 page)
- 5 – 20: DRAWINGS, SHEET C6.1 - “PARTIAL UTILITY PLAN”**, revise as follows:
- A. Replace drawing C6.1 in its entirety with drawing C6.1 attached. (1 page)
- 5 – 21: DRAWINGS, SHEET C6.2 - “PARTIAL UTILITY PLAN”**, revise as follows:
- A. Replace drawing C6.2 in its entirety with drawing C6.2 attached. (1 page)
- 5 – 22: DRAWINGS, SHEET C6.3 - “PARTIAL UTILITY PLAN”**, revise as follows:
- A. Replace drawing C6.3 in its entirety with drawing C6.3 attached. (1 page)
- 5 – 23: DRAWINGS, SHEET CX1.1 - “SITE DETAILS”**, revise as follows:
- A. Add the following note to detail K/CX1.1;
 - a. “PROVIDE CLASS 2 AGGREGATE BASE MATCHING ADJACENT ASPHALT CONCRETE PAVEMENT SECTION”
- 5 – 24: DRAWINGS, SHEET CX2.3 - “UTILITY DETAILS”**, revise as follows:
- A. Replace drawing CX2.3 in its entirety with drawing CX2.3 attached. (1 page)
- 5 – 25: DRAWINGS, SHEET L101 - “LANDSCAPE MULCHING PLAN”**, revise as follows:
- A. Replace drawing L101 in its entirety with drawing L101 attached. (1 page)
- 5 – 26: DRAWINGS, SHEET L201 - “LANDSCAPE PLANTING PLAN”**, revise as follows:
- A. Replace drawing L201 in its entirety with drawing L201 attached. (1 page)
- 5 – 27: DRAWINGS, SHEET L301 - “LANDSCAPE IRRIGATION PLAN”**, revise as follows:
- A. Replace drawing L301 in its entirety with drawing L301 attached. (1 page)

- 5 – 28: DRAWINGS, SHEET L403 - “LANDSCAPE AND IRRIGATION DETAILS”,** revise as follows:
- A. Replace drawing L403 in its entirety with drawing L403 attached. (1 page)
- 5 – 29: DRAWINGS, SHEET A200 - “FLOOR PLAN – BLDG A – ONLINE SCHOOL”,** revise as follows:
- A. Eliminate all references to window type ‘AW’. Walls to be continuous where window ‘AW’ was referenced.
- 5 – 30: DRAWINGS, SHEET A202 - “PARTIAL FLOOR PLAN – BLDG A – ONLINE SCHOOL - SOUTH”,** revise as follows:
- A. Revise detail 4 on drawing A202 with attached Addendum Drawing AD5-A05. (1 page)
- 5 – 31: DRAWINGS, SHEET A211 - “ENLARGED FLOOR PLAN – BLDG A – STEM A04, STEM PREP A05”,** revise as follows:
- A. Replace detail 22 on drawing A211 in its entirety with attached Addendum Drawing AD5-A03. (1 page)
 - B. Revise detail 8 on drawing A211 with attached Addendum Drawing AD5-A04. (1 page)
- 5 – 32: DRAWINGS, SHEET A601 - “PARTIAL REFLECTED CEILING PLAN – BLDG A – ONLINE SCHOOL - NORTH”,** revise as follows:
- A. Add the following symbol to the sheet A601 ‘LEGEND’;
 - a. “ - REFER TO A900 FOR INTERIOR FINISHES”
- 5 – 33: DRAWINGS, SHEET A602 - “PARTIAL REFLECTED CEILING PLAN – BLDG A – ONLINE SCHOOL - SOUTH”,** revise as follows:
- A. Revise detail 4 on drawing A602 with attached Addendum Drawing AD5-A06. (1 page)
 - B. Add the following symbol to the sheet A602 ‘LEGEND’;
 - a. “ - REFER TO A900 FOR INTERIOR FINISHES”
- 5 – 34: DRAWINGS, SHEET A651 - “PARTIAL REFLECTED CEILING PLAN – BLDG B – SPECIAL EDUCATION ADIM. - NORTH”,** revise as follows:
- A. Add the following symbol to the sheet A651 ‘LEGEND’;
 - a. “ - REFER TO A940 FOR INTERIOR FINISHES”
- 5 – 35: DRAWINGS, SHEET A652 - “PARTIAL REFLECTED CEILING PLAN – BLDG B – SPECIAL EDUCATION ADIM. - SOUTH”,** revise as follows:
- A. Add the following symbol to the sheet A652 ‘LEGEND’;
 - a. “ - REFER TO A940 FOR INTERIOR FINISHES”

- 5 – 36: DRAWINGS, SHEET A820 - “EXTERIOR OPENING TYPICAL DETAILS”,** revise as follows:
- A. Replace detail 10 on drawing A820 in its entirety with attached Addendum Drawing AD5-A01. (1 page)
- 5 – 37: DRAWINGS, SHEET A822 - “EXTERIOR/INTERIOR JAMB DETAILS”,** revise as follows:
- A. Replace detail 22 on drawing A822 in its entirety with attached Addendum Drawing AD5-A02. (1 page)
- 5 – 38: DRAWINGS, SHEET A831 - “INTERIOR OPENING DETAILS”,** revise as follows:
- A. Replace drawing A831 in its entirety with drawing A831 attached. (1 page)
- 5 – 39: DRAWINGS, SHEET A900 - “FINISH FLOOR PLAN – BLDG A – ONLINE SCHOOL”,** revise as follows:
- A. Replace drawing A900 in its entirety with drawing A900 attached. (1 page)
- 5 – 40: DRAWINGS, SHEET A910 - “INTERIOR ELEVATIONS – BLDG A – ONLINE SCHOOL”,** revise as follows:
- A. Replace drawing A910 in its entirety with drawing A910 attached. (1 page)
- 5 – 41: DRAWINGS, SHEET A911 - “INTERIOR ELEVATIONS – BLDG A – ONLINE SCHOOL”,** revise as follows:
- A. Replace drawing A911 in its entirety with drawing A911 attached. (1 page)
- 5 – 42: DRAWINGS, SHEET A912 - “INTERIOR ELEVATIONS – BLDG A – ONLINE SCHOOL”,** revise as follows:
- A. Replace drawing A912 in its entirety with drawing A912 attached. (1 page)
- 5 – 43: DRAWINGS, SHEET A913 - “INTERIOR ELEVATIONS – BLDG A – ONLINE SCHOOL”,** revise as follows:
- A. Replace drawing A913 in its entirety with drawing A913 attached. (1 page)
- 5 – 44: DRAWINGS, SHEET A914 - “INTERIOR ELEVATIONS – BLDG A – ONLINE SCHOOL”,** revise as follows:
- A. Replace drawing A914 in its entirety with drawing A914 attached. (1 page)
- 5 – 45: DRAWINGS, SHEET A915 - “INTERIOR ELEVATIONS – BLDG A – ONLINE SCHOOL”,** revise as follows:
- A. Replace drawing A915 in its entirety with drawing A915 attached. (1 page)

- 5 – 46: DRAWINGS, SHEET A916 - “INTERIOR ELEVATIONS – BLDG A – ONLINE SCHOOL”,**
revise as follows:
- A. Replace drawing A916 in its entirety with drawing A916 attached. (1 page)
- 5 – 47: DRAWINGS, SHEET A917 - “INTERIOR ELEVATIONS – BLDG A – ONLINE SCHOOL”,**
revise as follows:
- A. Replace drawing A917 in its entirety with drawing A917 attached. (1 page)
- 5 – 48: DRAWINGS, SHEET A918 - “INTERIOR ELEVATIONS – BLDG A – ONLINE SCHOOL”,**
revise as follows:
- A. Replace drawing A918 in its entirety with drawing A918 attached. (1 page)
- 5 – 49: DRAWINGS, SHEET A919 - “INTERIOR ELEVATIONS – BLDG A – ONLINE SCHOOL”,**
revise as follows:
- A. Replace drawing A919 in its entirety with drawing A919 attached. (1 page)
- 5 – 50: DRAWINGS, SHEET A920 - “INTERIOR ELEVATIONS – BLDG A – ONLINE SCHOOL”,**
revise as follows:
- A. Replace drawing A920 in its entirety with drawing A920 attached. (1 page)
- 5 – 51: DRAWINGS, SHEET A921 - “INTERIOR ELEVATIONS – BLDG A – ONLINE SCHOOL”,**
revise as follows:
- A. Replace drawing A910 in its entirety with drawing A910 attached. (1 page)
- 5 – 52: DRAWINGS, SHEET A922 - “INTERIOR ELEVATIONS – BLDG A – ONLINE SCHOOL”,**
revise as follows:
- A. Replace drawing A922 in its entirety with drawing A922 attached. (1 page)
- 5 – 53: DRAWINGS, SHEET A923 - “INTERIOR ELEVATIONS – BLDG A – ONLINE SCHOOL”,**
revise as follows:
- A. Replace drawing A923 in its entirety with drawing A923 attached. (1 page)
- 5 – 54: DRAWINGS, SHEET A924 - “INTERIOR ELEVATIONS – BLDG A – ONLINE SCHOOL”,**
revise as follows:
- A. Replace drawing A924 in its entirety with drawing A910 attached. (1 page)
- 5 – 55: DRAWINGS, SHEET A940 - “FINISH FLOOR PLAN – BLDG B – SPECIAL EDUCATION ADMIN.”,** revise as follows:
- A. Replace drawing A940 in its entirety with drawing A940 attached. (1 page)

- 5 – 56: DRAWINGS, SHEET A950 - “INTERIOR ELEVATIONS – BLDG B – SPECIAL EDUCATION ADMIN.”**, revise as follows:
- A. Replace drawing A950 in its entirety with drawing A950 attached. (1 page)
- 5 – 57: DRAWINGS, SHEET A951 - “INTERIOR ELEVATIONS – BLDG B – SPECIAL EDUCATION ADMIN.”**, revise as follows:
- A. Replace drawing A951 in its entirety with drawing A951 attached. (1 page)
- 5 – 58: DRAWINGS, SHEET A952 - “INTERIOR ELEVATIONS – BLDG B – SPECIAL EDUCATION ADMIN.”**, revise as follows:
- A. Replace drawing A952 in its entirety with drawing A952 attached. (1 page)
- 5 – 59: DRAWINGS, SHEET A953 - “INTERIOR ELEVATIONS – BLDG B – SPECIAL EDUCATION ADMIN.”**, revise as follows:
- A. Replace drawing A953 in its entirety with drawing A953 attached. (1 page)
- 5 – 60: DRAWINGS, SHEET A954 - “INTERIOR ELEVATIONS – BLDG B – SPECIAL EDUCATION ADMIN.”**, revise as follows:
- A. Replace drawing A954 in its entirety with drawing A954 attached. (1 page)
- 5 – 61: DRAWINGS, SHEET A956 - “INTERIOR ELEVATIONS – BLDG B – SPECIAL EDUCATION ADMIN.”**, revise as follows:
- A. Replace drawing A956 in its entirety with drawing A956 attached. (1 page)
- 5 – 62: DRAWINGS, SHEET A958 - “INTERIOR ELEVATIONS – BLDG B – SPECIAL EDUCATION ADMIN.”**, revise as follows:
- A. Replace drawing A958 in its entirety with drawing A958 attached. (1 page)
- 5 – 63: DRAWINGS, SHEET A959 - “INTERIOR ELEVATIONS – BLDG B – SPECIAL EDUCATION ADMIN.”**, revise as follows:
- A. Replace drawing A959 in its entirety with drawing A959 attached. (1 page)
- 5 – 64: DRAWINGS, SHEET A960 - “INTERIOR ELEVATIONS – BLDG B – SPECIAL EDUCATION ADMIN.”**, revise as follows:
- A. Replace drawing A960 in its entirety with drawing A960 attached. (1 page)
- 5 – 65: DRAWINGS, SHEET M200 - “OVERALL MECHANICAL FLOOR PLAN – BLDG A”**, revise as follows:
- A. Replace drawing M200 in its entirety with drawing M200 attached. (1 page)

ADDENDUM NO. 5

CUSD: Online School & Special Education
Page 8

- 5 – 66: DRAWINGS, SHEET M905 - “TITLE 24 DOCUMENTATION”,** revise as follows:
- A. Add “ACCEPTANCE TESTING & FUNCTIONAL TESTING REQUIREMENTS” to M905, attached. (1 page)
- 5 – 67: DRAWINGS, SHEET E210 - “POWER PLAN – BLDG A”,** revise as follows:
- A. Replace drawing E210 in its entirety with drawing E210 attached. (1 page)
- 5 – 68: DRAWINGS, SHEET E220 - “POWER PLAN – BLDG B”,** revise as follows:
- A. Replace drawing E220 in its entirety with drawing E220 attached. (1 page)
- 5 – 69: DRAWINGS, SHEET E410 - “SIGNAL PLAN – BLDG A”,** revise as follows:
- A. Replace drawing E410 in its entirety with drawing E410 attached. (1 page)
- 5 – 70: DRAWINGS, SHEET E420 - “SIGNAL PLAN – BLDG B”,** revise as follows:
- A. Replace drawing E420 in its entirety with drawing E420 attached. (1 page)

END OF ADDENDUM NO. 5

Jamie Miller
Architect of Record

SECTION 115213
PROJECTION SCREENS

PART 1 - GENERAL

1.1 RELATED DOCUMENTS

- A. Drawings and general provisions of the Contract, including General and Supplementary Conditions and Division 01 Specification Sections, apply to this Section.

1.2 SUMMARY

- A. Section Includes:

- 1. Electrically operated projection screens and controls.

- B. Related Sections:

- 1. Division 26 Sections for electrical service and connections including device boxes for switches and control wiring.

1.3 DEFINITIONS

- A. Gain of Front-Projection Screens: Ratio of light reflected from screen material to that reflected perpendicularly from a magnesium carbonate surface as determined per SMPTE RP 94.

1.4 SUBMITTALS

- A. Product Data: For each type of product indicated.

- B. Shop Drawings: Show layouts and types of projection screens. Include the following:

- 1. For electrically operated projection screens and controls:

- a. Location of screen centerline relative to ends of screen case.
 - b. Location of wiring connections for electrically operated units.
 - c. Drop lengths.
 - d. Anchorage details, including connection to supporting structure for suspended units.
 - e. Details of juncture of exposed surfaces with adjacent finishes.
 - f. Accessories.
 - g. Wiring diagrams.

- C. Maintenance Data: For projection screens to include in maintenance manuals.

1.5 QUALITY ASSURANCE

- A. Source Limitations for Projection Screens: Obtain projection screens from one source and from a single manufacturer. Obtain accessories, including necessary mounting hardware, from screen manufacturer.
- B. Electrical Components, Devices, and Accessories: Listed and labeled as defined in NFPA 70, by a qualified testing agency, and marked for intended location and application.

1.6 DELIVERY, STORAGE, AND HANDLING

- A. Environmental Limitations: Do not deliver or install projection screens until spaces are enclosed and weathertight, wet work in spaces is complete and dry, and temporary HVAC system is operating and maintaining ambient temperature and humidity conditions at occupancy levels during the remainder of the construction period.

1.7 COORDINATION

- A. Coordinate layout and installation of projection screens with adjacent construction, including ceiling suspension systems, light fixtures, HVAC equipment, fire-suppression system, and wall and ceiling framing.
- B. Coordinate installation of motor operated projection screens with electrical work

PART 2 - PRODUCTS

2.1 SCHEDULED PROJECTION SCREENS

- A. General: Provide projection screens to comply with requirements in this Section and as scheduled in Part 3 "Projection Screen Schedule."
- B. Basis-of-Design Products: Products indicated in this Section are based on products manufactured by:
 - 1. The Da-Lite Screen Company.
 - a. Subject to compliance with requirements, provide products indicated or comparable products by one of the following:
 - 1) Bretford, Inc.
 - 2) Draper Inc.

2.2 PROJECTION SCREENS, GENERAL

- A. Rollers: Manufacturer's standard rollers of sizes and material as recommended by manufacturer.

- B. Bottom Bar: Manufacturer's standard weighted bottom bar.
- C. Screen Mounting: Top edge of screen to be securely anchored to a rigid steel roller; bottom edge formed into a pocket holding a tubular metal slat, with ends of slat protected by plastic caps, and with a saddle and pull attached to slat by screws.
- D. Tab Tensioning: Where indicated, provide units with a durable low-stretch cord on each side of screen connected to edge of screen by tabs to maintain even lateral tension to hold viewing surface flat.
- E. Controlled Screen Return: Where indicated, provide units with manufacturer's standard controlled screen return to limit the speed of return to ensure a smooth return.

2.3 ELECTRICALLY OPERATED PROJECTION SCREENS

- A. General: Manufacturer's standard units consisting of case, screen, motor, controls, mounting accessories, and other components necessary for a complete installation. Provide units that are listed and labeled as an assembly by UL or another testing and inspecting agency acceptable to authorities having jurisdiction.
 - 1. Controls: Remote, key-operated, three-position control switch installed in recessed device box with flush cover plate matching other electrical device cover plates in room where switch is installed.
 - a. Provide power supply for low-voltage systems if required.
 - b. Provide video interface control for connecting to projector. Projector provides signal to raise or lower screen.
- B. Suspended, Electrically Operated Screens with Ceiling Closure: Motor units housed inside metal roller and including automatic thermal overload protection, integral gears, capacitor, and electric brake to prevent coasting. Designed and fabricated for suspended mounting, with self-trimming flange. Locate motor in its own compartment.

2.4 FRONT-PROJECTION SCREEN MATERIAL

- A. Screen Material
 - a. Mildew-Resistance Rating: 0 or 1 when tested according to ASTM G 21.
 - b. Flame Resistance: Passes NFPA 701.
 - c. Flame-Spread Index: Not greater than 75 when tested according to ASTM E 84.

- B. Seamless Construction: Provide screens, in sizes indicated, without seams.
 - 1. Where length of screen indicated exceeds maximum length produced without seams in material specified, provide screen with horizontal seam placed at top of screen at juncture between extra drop length and viewing surface.
- C. Edge Treatment: Black masking borders.
- D. Extra Drop Length: Where required or indicated, provide extra drop length.
 - 1. Color: Black.

PART 3 - EXECUTION

3.1 PROJECTION SCREEN INSTALLATION

- A. Install projection screens at locations indicated to comply with screen manufacturer's written instructions.
- B. Install projection screens with screen cases in position and in relation to adjoining construction indicated. Securely anchor to supporting substrate in a manner that produces a smoothly operating screen with vertical edges plumb and viewing surface flat when screen is lowered.
 - 1. Install low-voltage controls according to NFPA 70 and complying with manufacturer's written instructions.
 - a. Wiring Method: Install wiring in raceway except in accessible ceiling spaces and in gypsum board partitions where unenclosed wiring method may be used. Use UL-listed plenum cable in environmental air spaces, including plenum ceilings. Conceal raceway and cables except in unfinished spaces.
 - 2. Test electrically operated units to verify that screen controls, limit switches, closures, and other operating components are in optimum functioning condition.
 - 3. Test manually operated units to verify that screen-operating components are in optimum functioning condition.

3.2 PROJECTION SCREEN SCHEDULE

- A. Projection Screen PS-1
 - 1. Basis of Design: Da-Lite Screen Company; Tensioned Large Advantage Electrol
 - 2. Location: Building A, Flex Room C
 - 3. Type: Tensioned Screen in UL plenum-rated case
 - 4. Operation: Motor operated with remote control station.
 - 5. Mounting: Recessed in ceiling.
 - 6. Screen Size: 108 by 192 inches, height by width, seamless
 - 7. Screen Surface: Pearlescent with standard black backing

8. Options: Provide extra length such that bottom of viewing surface is 48 inches maximum above the floor

B. Projection Screen PS-2

1. Basis of Design: Da-Lite Screen Company; Tensioned Large Advantage Electrol
2. Location: Building A, Flex Room B
3. Type: Tensioned Screen in UL plenum-rated case
4. Operation: Motor operated with remote control station.
5. Mounting: Recessed in ceiling.
6. Screen Size: 90 x 160 inches, height by width, seamless
7. Screen Surface: Pearlescent with standard black backing
8. Options: Provide extra length such that bottom of viewing surface is 48 inches maximum above the floor

END OF SECTION

SUMMARY OF WORK (ADM 5)

PART 1 - GENERAL

1.01 SUMMARY

A. General: Construction of BASE BID and Alternate portions of the work for **Clovis Unified District Office Expansion – Online School & Special Education Administration**, Clovis, California. BASE BID and Alternate portions of the work are defined as all material, labor, equipment, and services necessary to do all work shown on the drawings and called for in the Specifications.

General Summary of the Project

The following information applies to all Bid packages and shall be reviewed carefully for inclusion in each bid. Following are critical logistics related to the Project:

1. Construction to include; Phase 1 of Clovis Unified's District Office Expansion. This phase consists of new construction of (2) 25000sf Structural Steel/Wood Framed Buildings including all new site utilities, new onsite/offsite improvements including sidewalks, landscaping, and parking lots.
2. All work for the project will be performed during the hours of 7:00a.m to 3:30p.m. Utility tie-ins may be required to be performed after hours.
3. Submittals and material procurement shall begin immediately upon award or letter of intent from the District.
4. Bid packages shall review the project completely prior to bidding the work.
5. Any substitution of details or materials must be pre-approved by the Architect, engineers, and DSA.

In addition to the summary of work for each Bid Package, the following will apply and become a part of the contract with each respective Bid package.

Storm Water Pollution Prevention Plan and Dust Control

1. Storm Water Pollution Prevention Plan (SWPPP) will become a part of the contract with each respective Bid Package. Initial SWPPP will be installed by the Earthwork Bid Package.
2. Provide BMP controls for own work, or as included in each bid package.
3. All work under each Bid Package shall comply with Air Pollution Control District Standards. Provide dust control and plan for own work.

Submittals and material procurement

1. Submittals and material procurement shall begin immediately upon award or letter of intent from the District.
2. Material procurement is critical and shall be diligently pursued to meet the contract schedule.

Contract

1. Please be advised that all successful bidders will be required to enter into a prime contract agreement with Clovis Unified School District.

Schedule

1. Bid packages shall review the project and schedule and site logistics plan completely prior to bidding the work.
2. The bid package will be required to provide a schedule and crew sizing showing how the work will be accomplished within the given time frame.

Crew Sizes

1. All bid packages shall review the schedule and confirm that they can crew the project accordingly prior to submitting a bid. Include with each bid minimum and maximum crew sizes projected for the project.

State Agency Requirements

1. All work shall comply with OSHA requirements, SWPPP, and Air Pollution Control District.

Coordination of work

1. Coordination of work during the preconstruction period is equally as critical to resolving all issues prior to the start of work. Bid package shall review the project, coordinate, and question any issues to allow resolution prior to the start of work.
2. Review and verify all existing conditions. Property dimensions as shown are based on record information and should be field verified by a property surveyor prior to construction.
3. All bid packages shall attend coordination meetings and provide coordination drawings for underground and above ceiling work and for coordination of utilities, openings and other areas that require interface between trades. Note conflicts and provide potential solutions to the architect for review. Coordination and drawing approval must occur prior to excavation (and/or) overhead work. Bid packages shall attend a pre-installation meeting prior to the start of their work onsite. All bid packages shall be available for pre-installation meetings of other bid packages for coordination of related work.
4. Provide written request for information through the CM for layout information from related trades for all rough-in, embedded items, openings, and block-outs, etc.
5. Request and review all associated shop drawings for coordination and layout purposes prior to installation of related materials.
6. Coordinate all work with mechanical, plumbing, and electrical Bid package for shut down of services as needed. (48) hours' notice is required prior to all shut down activities.
7. Review as-builts & underground locator survey & pothole utilities prior to starting work.

Temporary Utilities:

1. Temporary Construction Power will be provided by the Electrical Bid Package. Temp Construction Power to consist of the following:
 - a. Connect to existing 400A panel. Run (4) 2" conduits from existing panel to (2) locations at each building for a total of (4) locations. Provide all necessary wiring and components for hook up. Provide (1) temporary power box at each conduit location for a total of (4) temporary power boxes.
 - b. Temporary power boxes shall remain in service until completion of project or until permanent power is available at the buildings.
 - c. Provide daily inspection, testing and maintenance of temporary power system per OSHA regulations. Secure temporary power boxes from the end of each workday to the start of the next. **This will be the responsibility of the Electrical bid package. (ADM 5)**
 - d. Any additional power needed shall be provided by the bid package in need.
 - e. Lighting for own work areas to be provided by each package. Egress Lighting to be provided by electrical package. Locations per Electrical SOW.
2. Construction water will be available at the Fire Hydrant located on Herndon Ave (Contractor to verify). Each Bid Package will be responsible for providing their own water meter for water consumption. **Site utilities contractor to review SOW for added water connection information. (ADM 5)**

3. Portable Toilets will be provided by the Construction Manager.

Site Logistics:

1. Only company vehicles are allowed on the construction site. Personal vehicle will be confined to the designated parking lot on site. See access plan for specifics. No tool drop-off by personal vehicles will be allowed. Bid package to make provisions for transport or tool distribution needs.
2. Storage areas will be confined to the areas designated by the CM (see access plan). Staging areas around the building shall be coordinated with the CM. Storage onsite will be controlled due to limited space available.

General Items to be provided by each bid package:

1. Contact Underground Service Alert, and CUSD a minimum of (48 Hour Prior to Excavating or Digging).
2. Protect all work, new and existing, from damage until acceptance by owner.
3. Provide water and shade for own crews.
4. Furnish all access to roof for own work.
5. Provide dewatering for own work.
6. Furnish and install own floor protection (i.e., Tarps, plastic, plywood, etc.)
7. Furnish and install all physical layout for own work.
8. Each bid package will be responsible for removal from the site of all debris and spoils generated by each bid package. Daily clean up is required. Coordinate dumpster location with Construction Manager prior to setting. Comply with requirements of the plans and specifications for recycled content and reporting.
9. Secure all ladders and lifts each evening.
10. Provide protection of all roofing when own work requires access on the roofing systems.
11. Provide caution tape and/or barriers for open area work and traffic control.
12. Each bid package will be responsible for their wash out, wash out area as designated by the CM.
13. Provide hoisting/rigging for own work.
14. Review as-builts & underground locator survey & pothole utilities prior to starting work.
15. Contractors shall be responsible for encroachment permits and inspection fees related to the encroachment permits only. All other permits and fees will be paid by the District.
16. Contractors shall comply with codes listed in project plans.
17. Reference building commissioning specification for building systems to be commissioned.
18. Any substitution of details or materials must be pre-approved by the Architect, engineers, and DSA. All substitution requests must be submitted to MWC prior to bid. This Bid Package is responsible for all costs and time delays required for substitution approval.
19. Contractors shall schedule deliveries of equipment and materials separately for their installation in each building with CM. Materials shall not be stored on-site until the respective installation activity begins at each building. If warehousing of contractor equipment or materials is necessary, the contractor shall secure a bonded location and include such cost within the base bid amount.
20. Provide protection for workers during own work activities at elevated installations per OSHA regulations.
3. Furnish and install street cleaning for own scope of work as necessary. Any mud/debris will need to be cleaned up immediately as needed by the Bid Package responsible.
21. Provide copy of daily reports to Construction Manager each day work is performed on site.
22. Provide copy of weekly safety meeting sign in sheet to Construction Manager each week work is performed on site.

23. Provide copy of IIPP

DISTRICT PROVIDED SURVEY & UNDERGROUND LOCATING (FOR REFERENCE ONLY)

Provide Field Engineering/Survey Services per the following for Site and Offsite work:

Specific Requirements

1. Provide move-ins for each section of work as listed on the Project Baseline Schedule.
2. Calc trenching near footings to be outside angle of repose.
3. Furnish and install all survey for onsite work and offsite work.
4. Verify digital files provided by design team are the bid set documents prior to use.
5. Verify and stake property dimensions prior to construction.
6. Stake limit of first phase of construction.
7. Provide UG utility coordination and attend coordination meetings. Provide color coded clash detection drawing. Confirm there are no clashes between utilities nor trees, fence posts, poles, etc. Provide solutions to conflicts,

Earthwork:

1. Stake construction access roads, construction laydown yard, Temporary power panel location, and construction trailer locations to confirm locations do not conflict with new utilities or electrical service.
2. Staking for demolition of existing curbs.
3. Establish a minimum of two permanent horizontal and vertical control points on the site, remote from the building area. Referenced to data established by survey control points.
4. Staking for over excavation limits of Building pads.
5. Staking of parking lot curbs with offset determined by concrete bid package.
6. Staking of drain basins, streets, swales, and grade breaks.
7. Certify site grades after completion of rough grading.
8. Certification of site grades at project completion.

Under Ground Utilities:

1. Staking of all electrical and low voltage vaults, fixtures, flagpole lights, boxes, transformers, and switchgears – horizontal and vertical.
2. Stake all PG&E Rule 16 trenching and equipment locations.
3. Staking of all storm drain lines (manholes) and drain inlets, sewer lines and cleanouts (50'); domestic water, water meter, backflows, fire water, Irrigation service and backflow, gas lines, gas meters, vaults, EV charging stations, and monument sign (as required for excavation and installation horizontal and vertical) at the site.
4. All valve locations.
5. Stake all site lighting and camera poles.
6. Stake all fire Hydrants, check valves, FDC, and PIV locations.
7. Stake all irrigation sleeves, irrigation service, backflow preventer and booster pump.
8. Stake all lateral tees and POC's at all Buildings for all utilities.
9. Stake new FID Irrigation line and vents.
10. Certify rough grade after each utility installation.
11. Coordinate and stake for temp construction power pathways (see attached temp power plan)
12. Provide UG utility coordination and attend coordination meetings.

Site Concrete Work:

1. Staking for all concrete walks, curbs, gutters, mowstrips, signs, walls, flag poles, planters/seatwalls, equipment pads, bike racks, etc.... except concrete that can be determined off the edge of buildings.

Fencing:

1. Staking of chain link and ornamental fences and gates.
2. Staking for CMU fencing and trash enclosure.
3. Staking of fence mow strips – horizontal and vertical.

Buildings:

1. Provide 1 permanent horizontal and vertical control point at each building.
2. Staking for building corners determined by concrete bid package.
3. Provide survey for all building grid lines at building pad, reference points and radiuses as required.
4. Certify Building pads.
5. Certify steel column anchor bolts prior to concrete placement – horizontal and vertical.

Documents:

1. Cut sheets and reference drawings for all stake items.
2. Clash detection coordination study prior to site utility installation.
3. Color coded as-builts snapped off buildings.

Underground Locating:

1. Provide GPR underground locating for entire site. Provide dimensioned color coded document at completion of scan showing all utilities found.

End of Survey Scope

DOE-01 – Earthwork, Paving, and Demolition

Furnish and install all work specifically required throughout the project documents to complete the work of this bid package that specifically includes, but is not limited to the following:

Specification Sections

Division 00	General Conditions for Contracts on Construction Management Projects
Division 01	General Requirements
02 30 00	Subsurface Investigation
31 00 00	Off-site Development
31 11 00	Site Clearing
31 20 00	Earthwork
31 22 22	Soils Materials
31 50 00	Excavation Support and Protection
32 11 26	Aggregate Base Course
32 12 16	Soil Sterilization
32 12 17	Asphalt Concrete
32 13 73	Concrete Paving Joint Sealants
32 17 23	Pavement Markings
32 28 52	Parking Lot Furniture

Geotechnical Report

Refer to additional related specifications sections for work specifically included in this bid package noted below.

General Items

1. Furnish and install all layout for own work from survey provided by the district. See survey scope of work for reference. This bid package will be responsible for all additional layout not performed by the survey contractor.
2. There will be one wash-out area for each bid package as designated by the Construction Manager. Each bid package will be responsible for removal from the site of all debris and spoils generated by each bid package.
3. Provide all backfill of excavations to original sub-grade for work included in this bid package.
4. Provide all power for own work.
5. Provide dewatering for own excavations.
6. Protect survey stakes for own work and maintain until installations are complete.
7. Protect existing concrete curbs/lighting/drain inlets/hydrants/stubbed utility to remain. Install/maintain/remove snow fencing protection.
8. Review UG locator, and coordination drawings prior to demolition and advise of any conflict between existing utilities and demo scope.
9. Pothole to locate and verify the underground utility lines prior to removal. Utilities to be capped by utility contractor.
10. Perform re-compaction of fill materials in accordance with Geotech report recommendations or specifications. Perform over excavation at building areas in accordance with Geotech report recommendations.
11. Ensure off-site permit has been obtained by the owner prior to demolition activities within the county right-of-way.
12. See General Notes at beginning of summary of work specification section for other items.

Coordination with Other Trades

1. Coordinate and allow access to building pads for building related scope of work (concrete, plumbing, utilities, electrical)
2. Utilize all excess material spoils from utilities and foundations to complete grading. Other bid packages shall dump spoils at a designated location for grading by this bid package. Figure additional move-in utilize stockpiled material for fine grading and to remove excess material at completion of fine grading.
3. Coordinate all work with local utilities & electrical bid package for shut down of services prior to demo.
4. Obtain all permits required to perform the work. SWPPP will be obtained by the District and installed by this bid package.
5. Hold all turf areas down at concrete, mow strips, and planters per plans.

Furnish and Install Items

1. Furnish and install all clearing/stripping/grubbing, demolition, grading, paving, parking lot sealer, site signage for the project complete.

2. Provide own means of water supply for use during construction. If water tank is preferred, coordinate exact location onsite with CM. Provide temp water meter for own work. All costs associated with temp water usage shall be the contractors responsibility.
3. Furnish, install, and remove at completion all temporary SWPPP BMPs for the project complete. See SWPPP included in bid documents.
4. Obtain and cover all associated costs for traffic control plan for own work. Provide daily maintenance as necessary.
5. Remove site concrete as called for on plans. For concrete removal, remove to the nearest tooled joint or expansion joint of improvements designated to remain.
6. Remove all asphalt as called for on plans.
7. Remove wood barricades as called for on plans.
8. Provide all sawcut as shown for demolition. Include additional sawcut (and additional demo if needed) at completion of project for any existing asphalt that may have been damaged during construction.
9. Furnish and install street cleaning for own scope of work as required by municipal ordinance.
10. Grade all earthwork to within tolerances specified.
11. Furnish and install all cut/fill necessary to perform work. Excess dirt can be stockpiled at location designated on Phase 2 site adjacent to project.
12. Sand and vapor barrier to be furnished and installed by concrete package at the buildings only. All other materials shall be provided by this bid package.
13. Furnish and install fine grading of the site on separate move-ins (as scheduled by the construction manager) to accommodate the site concrete & mow strips installation. Coordinate backfill and final fine grading activities with the concrete bid package to eliminate damage to new site concrete.
14. Furnish and install all grading and swales for landscape to $\pm .10'$.
15. Maintain and protect building pads to within tolerance, elevation, moisture, weed free and compaction until accepted/received by the concrete package as noted in the schedule.
16. Furnish, install, maintain, and remove all temp access roads, staging, paved runoff area, and lay down areas as scheduled/directed by the CM and shown on the site logistics plan. See Site logistics plan for actual material, dimensions, and thickness required. Furnish, install, maintain and remove (2) controlled entrances per site logistics plan. Include 3 mobilizations to maintain/relocate controlled entrance stations as requested by the CM throughout construction.
17. Perform site stripping/grubbing in accordance with geotechnical report recommendation.
18. Furnish and install excavation of mow strips and thickened sections for site concrete.
19. Furnish and install backfill of mow strips, walks, curb, curb & gutter, planter, and turf areas.
20. Furnish and install additional cut at heavy duty concrete and paving areas. Provide compacted ag base at heavy duty concrete areas per Detail A/CX1.1
21. Furnish, install, and maintain traffic control for work included in this bid package.
22. Provide cleaning of asphalt paving areas prior to installation of final lift and at the end of the project for sealing (coordinate with the CM) per the schedule.
23. Flood test all A.C. paving prior to sealing. Provide for minor patching of asphalt at completion of project prior to sealing asphalt.

24. Furnish and install all site signage, striping, and concrete at posts at site complete.
25. Furnish and install painted curbs with lettering.
26. Furnish and install all wheel stops.
27. Furnish and install certification of final grading to confirm grades prior to landscape.
28. Furnish and install permanent asphalt patch for all street utility tie-ins and for all permanent and temporary curb modifications for approaches.
29. Provide caps/impalement protection for any impalement hazards such as concrete stakes, rebar, bolts, conduit, pipe, etc. Protection shall remain in place until impalement hazard is eliminated.
30. Provide additional mobilization at end of project to fine grade/repair any erosion and rutting in the ponding basins.
31. Furnish and install temp barricades as noted on Civil Drawings.
32. Furnish and install demolition/sawcut, earthwork, paving, and striping per City of Clovis Offsite Improvement Drawings. Obtain traffic control permit as required. Include H & K markers as required by drawings.
- 33. Furnish and install redwood header board as noted. (ADM 5)**

FOB Items

1. None.

Installation of FOB Items

1. None.

End of Bid Package

DOE-02 - Site Utilities

Furnish and install all work specifically required throughout the project documents to complete the work of this bid package that specifically includes, but is not limited to the following:

Specification Sections

Division 00	General Conditions for Contracts on Construction Management Projects
Division 01	General Requirements
02 30 00	Subsurface Investigation
22 05 00	Plumbing (as applies to site natural gas)
31 20 00	Earthwork (as applies to this bid package)
31 22 22	Soils Material (as applies to this bid package)
31 23 33	Trench, Excavation, and Backfill (as applies to this bid package)
31 50 00	Excavation Support and Protection (as applies to this bid package)
33 12 00	Water Utilities
33 30 00	Site Sewer Systems
33 40 00	Storm Drainage
Geotechnical Report	

Refer to additional related specifications sections for work specifically included in this bid package noted below.

General Items

1. Furnish and install all layout for own work from survey provided by the district. See survey scope of work for reference. This bid package will be responsible for all additional layout not performed by the survey contractor.
2. Construction water will be available at the Fire Hydrant located on Herndon Ave (Contractor to verify). Each Bid Package will be responsible for providing their own water meter for water consumption.
3. Furnish and install all sleeves in masonry, concrete, and foundations prior to the installation of concrete and reinforcing steel. Coordinate location with other related bid packages prior to excavation.
4. Furnish off-haul of all excavation spoils upon compaction of trench sections to point onsite as directed for work included in this bid package. Earthwork package to use spoils for completion of import materials. Provide spoils amount for this contract to Earthwork bid package within 10 days of award of contract.
5. There will be one wash-out area for each bid package as designated by the Construction Manager. Each bid package will be responsible for removal from the site of all debris and spoils generated by this bid package.
6. Provide dewatering for own excavations.
7. Provide trench shoring as required.
8. Provide trench plates at excavation as required to allow access for other trades.
9. Ensure owner has obtained city permit prior to off-site tie-ins/POC.
10. See General Notes at beginning of summary of work specification section for other items.

Coordination with Other Trades

1. Provide coordination drawings for underground work related to this bid package. Coordinate all drawings with the drawings of other bid packages. Note conflicts and provide potential solutions to the architect for review. Coordination must occur prior to excavation and/or installation of the work. Attend all coordination meetings required to coordinate all underground and above ceiling work. Provide a detailed site work schedule to coordinate with other utilities.
2. Coordinate all work to provide access to buildings for other trades as scheduled. Provide an underground utility schedule of where and when piping operations will be performed. Coordinate with other activities in the schedule for other trades and confirm the schedule meets the CMBS dates.
3. Building Plumbing bid package shall make physical connections to site utilities.
4. Purity tests are required on all water system installations. Contractor to coordinate with the Authority having jurisdiction.
5. Clean and disinfect all site piping. Create disinfection plan and coordinate with building bid packages to allow for complete and maintained disinfection of the entire system until acceptance by owner. Building Plumbing bid package will be responsible for cleaning and disinfection of building piping.
6. At conflicts with electrical duct banks, electrical duct banks are to have the lower elevations.
7. Provide trenching plan and permits for excavations over 5' per OSHA requirements to the construction manager.

8. Installation of irrigation sleeves shall be by the Irrigation Bid package.
9. Coordinate locations of all valve boxes and manholes away from doorways.
10. Coordinate location of site utility installations with location of building structure foundations to maintain clearance outside the foundation angle of repose.
11. Protect survey stakes for own work and maintain until installations are complete.
12. Coordinate with fire sprinkler contractor for POC at building riser locations.
13. Coordinate site utilities to miss all other site improvements including landscaping.
14. Provide detailed schedule for all work included in this bid package.

Furnish and Install Items

1. Furnish and install street cleaning for own scope of work as required by municipal ordinance.
2. Obtain and cover all associated costs for traffic control plan for own work. Provide daily maintenance as necessary.
3. Furnish and install all underground utilities onsite and offsite. Obtain and pay fees for encroachment permits as required. Provide demo and temporary patchback for utility tie ins at street. Any demo at gutters/approaches shall be temporarily addressed/modified to prevent standing/interrupted water flow. Certify grades have been returned to original grade. Special conditions are as follows:
 - a. Furnish, install, and maintain 2x4 marker stakes indicating end and depth of service for connection by other bid packages. Provide as-built points for each end of service on as-built drawings. Should inaccurate information be recorded, this bid package will be responsible for the costs of locating the end of service.
 - b. Pothole and confirm locations of existing plumbing utilities prior to excavation and maintain marking during construction.
 - c. Fire Water- Furnish and install all fire line piping complete with stub into all buildings per plan AFF. Stub with flange fitting, and cap for Fire sprinkler contractor. Furnish and install all detector check valves, FDC's, PIV's, christy boxes, required cages, and fire hydrants, paint per local authority standards. Coordinate fire alarm connections to be installed by the electrical bid package. Perform tie-in to street utility. Confirm City of Clovis Process.
 - d. Storm Drain, Sewer, and Domestic Water - Install all utilities to designated locations on site, or capped to within 5' of building, or designated POC for hook up by other building package. Furnish and install shut off valve at POC. Furnish and install back flow prevention/RP devices with protection enclosures complete. Furnish and install new domestic water meter. Perform tie-in to street utility. Furnish and install concrete structures at ponding basins. Include all necessary excavations, rebar/steel angle, concrete, and grates for complete structure installation.
 - e. Landscape Irrigation line – Site Irrigation main lines to be installed by the irrigation bid package including the booster pump. Irrigation service tie in at street and backflow prevention/RP device to be installed by Site Utilities package. Furnish and install new irrigation water meter.
 - f. Site Gas – Site gas to be furnished and installed by this bid package. Medium pressure gas lines to be provided up to 5' outside building footprint. Shut-off valve and boxes to be furnished and installed by this bid package. ~~PG&E Gas Utility barrier posts and concrete foundations per PG&E Drawings to be furnished and installed by this package.~~ **(ADM 5)** Pothole existing high pressure gas line. PG&E to perform hot tap and install utility meter per approved design drawing.

- g. FID Irrigation Pipe – Remove and properly dispose of existing FID irrigation pipe/standpipe/vent and replace with new pipe per Fresno Irrigation District Drawings. Contractor to pothole and verify existing horizontal/vertical locations and size of pipe prior to completing any additional work and report findings to FID. Include tracer wire and macwrap per FID standard drawings. Make physical connections at both ends of new pipe. Include all necessary fittings and reinforcement, waterstop, and bedding per FID Standards. Provide venting tubes as required. Irrigation Tie-ins shall be complete no later than February 15, 2024.
4. Install all utilities to within 5' of building or designated POC for hook up by other bid packages except as noted above.
5. Furnish and install all backfill and compaction of excavations to original subgrade for work included in this bid package.
6. Furnish and install all concrete required for installation of thrust blocks, manholes, vaults, boxes, underground structures, for work related to this bid package.
7. Furnish, install, and maintain protection of work included in this bid package from damage and intrusion of dirt and / or debris into the piping systems for the length of the project per the SWPPP. Protection shall allow use, as directed by the District, of the underground utility systems during construction for construction and testing operations without the start of the warranty period until the notice of completion for the project. Any dirt/debris that enters storm drain piping shall be removed and cleaned by this package at completion of project prior to owner turnover. Set inlets to allow drainage until site finishes are installed. Raise to proper elevation prior to installation of site concrete finishes. Raise all site utilities to grade in paving areas once paving is complete. Provide all patch back as necessary.
8. Furnish and install all signage and lettering called for in the contract documents related to work of this bid package.
9. Provide camera/ video inspection of all sewer and storm drain piping to show proper flow and cleanliness. Provide tape to owner for review prior to final acceptance of the project. This is for piping larger than 6".
10. Furnish and install pipe bollards/sleeves/foundations as shown at new fire hydrant locations.
11. Furnish and install caps with appropriate fittings at any utilities that call to be stubbed for future.
12. Raise all utilities to grade in paving areas once paving is complete. Provide all patch back as necessary.
13. Adjust all new and existing utility boxes/structures to grade in landscape and concrete/ac-paving areas.
14. Furnish, install, and maintain protection of work included in this bid package from damage and intrusion of dirt and / or debris into the piping systems for the length of the project per the SWPPP. Protection shall allow use, as directed by the District, of the underground utility systems during construction for construction and testing operations without the start of the warranty period until the notice of completion for the project. Any dirt/debris that enters storm drain piping shall be removed and cleaned by this package at completion of project prior to owner turnover. Set inlets to allow drainage until site finishes are installed. Raise to proper elevation prior to installation of site concrete finishes. Raise all site utilities to grade in paving areas once paving is complete. Provide all patch back as necessary.

15. Provide caps/impalement protection for any impalement hazards such as concrete stakes, rebar, bolts, conduit, pipe, etc. Protection shall remain in place until impalement hazard is eliminated.
16. **Furnish and install underground water line from fire hydrant located at parking lot entrance on Herndon Ave to northwest corner of project site. Stub water above ground with valve for water meter attachment. Provide flexible connection from hydrant to underground water supply. Provide necessary restraints at water line as required. This work shall take place as soon as project starts to allow water service for construction. (ADM 5)**

FOB Items

1. None.

Installation of FOB Items

1. None.

End of Bid Package

DOE-03 – Concrete (W/Rebar)

Furnish and install all work specifically required throughout the project documents to complete the work of this bid package that specifically includes, but is not limited to the following:

Specification Sections

Division 00	General Conditions for Contracts on Construction Management Projects
Division 01	General Requirements
02 30 00	Subsurface Investigation
03 15 12	Post Installed Concrete Anchors
03 30 00	Cast-in-place Concrete
03 35 18	Concrete Cure-Sealer-Hardener
03 39 10	Topical Concrete Vapor Control Barrier
07 26 16	Underslab Vapor Retarder
07 92 00	Joint Sealants
31 20 00	Earthwork (as applies to this bid package)
31 31 16	Termite Control
32 13 13	Site Concrete Improvements
32 13 15	Concrete Reinforcement (as applies to this bid package)
32 33 10	Tactile Detectable Warning Surface Tile
Geotechnical Report	

Refer to additional related specifications sections for work specifically included in this bid package noted below.

General Items

1. Furnish off-haul of all excavation spoils to point onsite as directed for work included in this bid package. Earthwork package to use spoils for completion of import materials. Provide spoils amount for this contract to Earthwork bid package within 10 days of award of contract.

2. There will be one wash-out area for each bid package as designated by the Construction Manager. This bid package will be responsible for removal from the site of all debris generated by this bid package.
3. Provide all backfill of excavations to original sub-grade for work included in this bid package.
4. Provide all clean up and provide off-haul of own debris from site.
5. Provide dewatering for own excavations.
6. Ensure owner has obtained county permit prior to off-site and curb/approach modifications.
7. Construction water will be available at the Fire Hydrant located on Herndon Ave (Contractor to verify). Each Bid Package will be responsible for providing their own water meter for water consumption.
8. See General Notes at beginning of summary of work specification section for other items.

Coordination with Other Trades

1. Review and coordinate layout for all blockouts in concrete as shown in the contract documents, related shop drawings or written layout provided by other bid packages. Coordinate locations with related bid packages prior to installation.
2. Coordinate dimensions with other related bid packages of all equipment and housekeeping pads. Pad sizes shall be provided by other bid packages and physically laid out and installed by this bid package.
3. This bid package will receive all building pads and site at tolerances listed in earthwork specification. This package will be responsible for all additional cut and fill necessary to complete the work of this bid package.
4. Provide access to other trades through reinforcing steel for installation of their work at building lines.
5. Provide layout drawings for all site and building concrete joints for approval prior to installation of concrete.
6. Receive and coordinate written layout from other bid packages for items embedded in or passing through concrete. All sleeves are to be installed by the utility bid packages.
7. Coordinate all embedded items within work included in this bid package that are to be installed at a later time such as fences, posts, etc.
8. Coordinate installation of all sleeves for work passing through masonry/concrete work with respective bid packages prior to excavation. Coordinate guardrail/handrail layout with steel contractor.
9. Coordinate all work to provide access to buildings for other trades as scheduled.
10. Install and coordinate block-outs at the site concrete to facilitate installation of fine grading by Earthwork Bid Package and to protect concrete until fine grading is complete. Complete site concrete block-outs once fine grading is complete. Backfill and fine grade once block-outs have been poured.
11. Earthwork bid package shall hold back earthwork at concrete foundations, footings, etc.. Coordinate hold back dimension with the Earthwork Bid Package of earthwork grading to allow installation of curb/gutter, trash enclosure walls, etc. Backfill by this package.

12. Electrical and site utility bid package shall furnish and install all concrete required for installation of thrust blocks, manholes, vaults, boxes, underground structures, for work related to their bid package.
13. Irrigation sleeves will be installed by the irrigation bid package. Coordinate schedule.
14. Coordinate the location of depressions, block outs, slopes, and drains prior to pour. Coordinate depressed and sloped floors in restrooms and sloped floors at accessible showers with flooring contractors and plumbing contractor for slope to drain.
15. Coordinate and provide floor flatness to comply with concrete specification standards.
16. Physically layout and install all blockouts, openings, etc. in concrete from written layout provided by other contractors for installation of their work.
17. Protect survey stakes for own work and maintain until installations are complete.

Furnish and Install Items

1. Furnish and install all building and site concrete complete including required excavations and rebar. Maintain moisture content at building slab-on-grade areas after acceptance of building pads from earthwork contractor in compliance with geotechnical report recommendation.
2. Furnish and install concrete at play structure. Include all flat work, curb, and ramp. Foundations at play structure poles to be by General Specialties Package.
3. Furnish and install backfill for own work.
4. Furnish and install street cleaning for own scope of work as required by municipal ordinance.
5. Obtain and cover all associated costs for traffic control plan for own work. Provide daily maintenance as necessary.
6. Furnish and install all sand and vapor barrier as detailed at concrete SOG.
7. Furnish and install all CMU foundations including excavation and rebar with lap splice per contract docs for continuation by masonry contractor. Layout of vertical rebar to be provided by CMU contractor.
8. Furnish and install saw cuts in slabs with joint filler. Provide shop drawings for review prior to installation.
9. Furnish and install all concrete collars as required for site utilities including but not limited to: cleanouts, valves, pull boxes, vaults, etc.
10. Furnish and install concrete columns.
11. Furnish and install concrete pad under backflow prevention devices.
12. Furnish and install light pole bases including excavation, concrete, reinforcing steel and backfill.
13. Furnish and install all grouting and/or dry pack for structural steel and misc. iron and light pole bases.
14. Furnish and install excavation, rebar and concrete fill of deepened foundations and rebar for all utilities passing through foundations from physical layout provided by others.
15. Furnish and install all concrete equipment & housekeeping pads, supports and foundations for fixtures and equipment. Non-concrete supports are by respective bid packages.
16. Furnish and install concrete pads for gas meter and main switchboard located in Utility Enclosure.
17. Furnish and install all handicap ramp truncated domes.

18. Furnish and install trash bin enclosure concrete complete including CMU wall foundations.
19. Furnish and install permanent concrete curb patch for all street utility tie-ins.
20. Furnish and install blockouts for steel. Cover and protect until steel and concrete placement.
21. Furnish and install Integral Concrete Floor Moisture Vapor Emission Control System as shown.
22. Furnish and install termite control at buildings.
23. Furnish and install saw cuts in slabs with joint filler. Provide shop drawings for review prior to installation.
24. Furnish and install sealant at concrete floors, building concrete to concrete and concrete to masonry.
25. Furnish and install all drypacking at wall sill plates as required.
26. Furnish and install all wood embedded in concrete.
27. Furnish and install cleaning, dewatering and protection of anchor bolts until turn over to structural steel erection or setting of leveling nuts.
28. Provide all cut required for minor depressions for tile and slopes to drain.
29. Protect all slab block outs for other trades working in the area.
30. Furnish and install excavation, rebar and concrete fill of deepened foundations and rebar for all utilities passing through foundations from physical layout provided by others.
31. Furnish and install all floor prep for floors out of tolerance to comply with concrete specification standards.
32. Furnish and install concrete floor hardener and concrete sealer at sealed floors.
33. Furnish and install all concrete equipment & housekeeping pads, supports and foundations for fixtures, tanks & equipment. Non-concrete supports are by respective bid packages.
34. Furnish and install recessed concrete at Nanawall sill per 14/A823.
35. Furnish, install, maintain, and remove floor protection at all exposed Building floors until sealed concrete finish is complete.
36. Provide caps/impalement protection for any impalement hazards such as concrete stakes, rebar, bolts, conduit, pipe, etc. Protection shall remain in place until impalement hazard is eliminated.
37. Furnish and install all concrete required at median including colored stamped concrete per City of Clovis Offsite Improvement Drawings. Obtain traffic control permit as required.

FOB Items

1. None.

Installation of FOB Items

Note. Unload, inventory, store and notify of deficiencies for all items delivered to the jobsite FOB, to be installed by this bid package:

1. Install all sleeves, handrails, queuing rails, traffic rails, guard rails complete including grout embedded in concrete as provided FOB jobsite.
2. Install all items embedded in concrete (i.e., anchor bolts, hold downs, plates, ledgers, angles, non-bolted tube steel, rails, sleeves, pipe rail, flagpole bases, poles, etc.) as

- provided FOB jobsite by other bid packages from written layout provided by those bid packages.
3. Install light pole anchor bolts and templates furnished FOB by the electrical contractor.
 4. Install flagpole base foundation (including excavation) provided FOB by General Specialties Package.
 5. Install and remove when complete all bolt templates provided by other bid packages.
 6. Install embedded fence accessories FOB by fencing contractor.
 7. Install FOB guard rails at building drinking fountains.
 8. Install all framing sill bolts and hold down bolts as provided FOB by the framing package. All layout will be furnished and installed by the framing package.

End of Bid Package

DOE-04 – Building Steel & Fabrications / Metal Decking / Railings

Furnish and install all work specifically required throughout the project documents to complete the work of this bid package that specifically includes, but is not limited to the following:

Specification Sections

Division 00	General Conditions for Contracts on Construction Management Projects
Division 01	General Requirements
03 15 12	Post Installed Concrete Anchors (as applies to this bid package)
05 12 00	Structural Steel Framing
05 31 00	Steel Decking
05 50 00	Metal Fabrications
05 51 33	Metal Ladders

Refer to additional related specifications sections for work specifically included in this bid package noted below.

General Items

1. Provide erection plan prior to erection of buildings.
2. Provide protection of utilities from cranes and equipment. There will be no crane access on the slab.
3. See General Notes at beginning of summary of work specification section for other items.
4. Provide all hoisting/rigging for work in this bid package.
5. Provide all clean up and off-haul of own debris from site.
6. Provide temp power for own work beyond what is provided by the electrical bid package. Refer to Electric Bid Package for specific information.
7. Provide off loading for all FOB items in areas as designated by the CM.

Coordination with Other Trades

1. Provide coordination drawings for above ceiling work and openings for work related to this bid package. Coordinate all drawings with the drawings of other bid packages. Note conflicts and provide potential solutions to the architect for review. Coordination

- must occur prior to installation of the work. Attend all coordination meetings required to coordinate all underground and above ceiling work.
2. Request and receive layout (prior to detailing and fabrication) from other bid packages for all items that require holes, openings, reinforcing or bracing related to this bid package's scope of work including but not limited to, bolt holes for attachment, HVAC supports, etc....Allow 21 days for return of dimensions. Provide coordination drawings for dimension mark up by other bid packages.
 3. Coordinate all steel through framing and finishes to assure proper fit.
 4. Provide a written crane access plan, laydown areas, and movement schedule for coordination with other contractors. Refer to site logistics plan for crane access to buildings. Stabilization of base under erection crane shall be the responsibility of the steel erection contractor if location of crane is outside of access road to buildings. Cranes shall not be allowed on building slabs. Provide non-marking tires for lift equipment on building slabs.
 5. Provide setting plan to concrete contractor and certify all anchor bolt layout at least 21 days prior to erection of structural steel. Report any bolts out of tolerance to the construction manager for correction by the concrete bid package.
 6. Coordinate priming of structural steel with installation of other materials prior to priming of steel and miscellaneous iron.
 7. Water heater brackets are to be furnished and installed by the plumbing bid package.
 8. Coordinate edge of slab dimensions with the concrete and framing bid packages prior to installation of slab on grade to assure proper tolerances can be maintained for the wood framing.
 9. Coordinate locations of handrail brackets with plaster contractor at exterior walls for stucco block outs.
 10. This contractor shall confirm and coordinate all dimensions for structural steel, wood, and metal fabrications furnished by this package. Procure all related information so as not to delay installations as scheduled in the project baseline schedule.
 11. Coordinate with Rough Carpentry contractor for wood nailer to beam connections.

Furnish and Install Items

1. Furnish and install street cleaning for own scope of work as required by law municipal ordinance.
2. Furnish and install all Structural Steel, Miscellaneous Iron, and Metal Decking at buildings and canopies not furnished FOB jobsite as noted below.
3. Physically layout and install all block outs, openings, bracing and holes in steel from written layout provided by other bid packages.
4. Furnish and install all steel guardrails/handrails.
5. Furnish and install all primer touch up at welding at structural steel and where chipping occurs from shipping /installation prior to acceptance by painting contractor.
6. Set leveling nuts at anchor bolts to the proper elevation for structural steel installation, assume protection of bolts from the concrete contractor.
7. Furnish and install all tube steel assemblies and angles.
8. Furnish and install all pipe rails, handrails, hold open posts / rails, and guard rails not directly embedded in concrete or masonry.
9. Furnish and install all drilling, epoxy of bolts and wedge anchors for steel and misc. iron at concrete and CMU.

10. Furnish and install all misc. iron & angles attached to concrete and masonry. Provide attachment if not shown to be embedded.
11. Furnish and install all ladders including roof access ladders at roof hatch and roof access ladders on roof. Refer to A880 & A881 for additional info.
12. Furnish and install all attachment devices for handrails.
- ~~13. Furnish and install perforated metal panels. (ADM 5)~~
14. Furnish and install perforated metal screens and grills.
15. Furnish and install continuous L metal per 5/A895.
16. Furnish and install canopies and sunshades complete, to include all decking, angles, grating, etc. All canopy steel, accessories, and components to be galvanized. Review architectural drawings to confirm complete scope.
17. Provide holes in beams for installation of partition walls. Coordinate with Partition wall contractor for exact hole requirements.
18. Provide caps/impalement protection for any impalement hazards such as concrete stakes, rebar, bolts, conduit, pipe, etc. Protection shall remain in place until impalement hazard is eliminated.

FOB Items

1. Furnish FOB jobsite all column bolts, ledger bolts, counter bracket assemblies, hardware bolts/washers/nuts for wood to steel and steel to concrete connections and other miscellaneous iron that embeds into concrete and masonry or attaches to framing for installation by those bid packages.
2. Furnish FOB jobsite all bolt templates for all patterns (made of steel) assembled with bolts, nuts, and washers ready for use/installation by the concrete bid package. Deliver, and off-load in an area designated by the CM all templates/anchor bolts for steel columns assembled to the jobsite. Predrill holes oversized for bolt installation. Provide acceptance of anchor bolt installation prior to setting steel columns.
3. Furnish FOB jobsite all associated sleeves for ~~fencing~~ **(ADM 5)**, handrails, and guard rails, etc.... and provide physical layout for installation by the concrete bid package.
4. Furnish embed plates and angles with rebar per contract documents FOB Jobsite for installation by others.
5. Furnish FOB Jobsite all casework support columns and brackets per 9, 10, 14, 18/A861 and similar.
6. Furnish FOB guard rails at building drinking fountains.
7. Predrill holes for fabricated fasteners. Coordinate layout for holes with framing contractor.
- ~~8. Furnish threshold and slab edge angles. (ADM 5)~~

Installation of FOB Items

1. None.

End of Bid Package

DOE-05 – Rough Carpentry

Furnish and install all work specifically required throughout the project documents to complete the work of this bid package that specifically includes, but is not limited to the following:

Specification Sections

Division 00	General Conditions for Contracts on Construction Management Projects
Division 01	General Requirements
03 15 12	Post Installed Concrete Anchors
06 10 00	Rough Carpentry
06 16 00	Plywood Panel Sheathing
06 18 00	Glue-Laminated Construction

Refer to additional related specifications sections for work specifically included in this bid package noted below.

General Items

1. Provide protection of slab and utilities from cranes and equipment.
2. Provide all hoisting/rigging for work included in this bid package.
3. Provide permits for scaffolding as required.
4. Furnish clean up daily and off-haul of all debris generated by own work.
5. Construction water will be available at the Fire Hydrant located on Herndon Ave (Contractor to verify). Each Bid Package will be responsible for providing their own water meter for water consumption.
6. Temp power will be provided by the Electrical Bid Package. See Electrical SOW for exact requirements. Any temp power required beyond what is described under the electrical package will be the responsibility of this package.
7. See General Notes at beginning of summary of work specification section for other items.

Coordination with Other Trades

1. Coordinate and install, from written layout, all blocking, backing, etc. for other contractors from written layout provided. Physical layout to be by this contractor.
2. Coordinate concrete curb vs. framing to assure proper alignment.
3. Provide coordination drawings for above ceiling work for work related to this bid package. Coordinate all drawings with the drawings of other bid packages. Note conflicts and provide potential solutions to the architect for review. Coordination must occur prior to installation of the work.
4. Coordinate and provide wall flatness with finish trades to comply with product installation standards.
5. Coordinate locations of window and door frames installed by General Specialties Bid Package. Guarantee door and window opening sizes to be square, plumb, and level.
6. Coordinate with mechanical and electrical contractors for location and size of equipment for platforms built by this bid package including all bolts/hardware.
7. Coordinate with ceramic tile contractor all rough framing dimensions required to meet ADA.
8. Provide review and verification of space for ADA requirements prior to framing. Note all discrepancies.

9. This contractor shall confirm and coordinate all dimensions for wood framing furnished by this package. Procure all related information so as not to delay installations as scheduled in the project baseline schedule.
10. Coordinate with Building Steel contractor for wood nailer to beam connections.
11. Coordinate penetrations through walls for mechanical ducts with HVAC contractor.
12. Coordinate wood nailers/sill at vertical steel after blockout pours.
13. This project has polished concrete floors in several rooms/areas. No markings/paint or bracing attachment will be allowed on polished concrete areas.

Furnish and Install Items

1. Furnish and install all wood framing including but not limited to all lumber, plywood, engineered wood and I-joists systems on the project.
2. Furnish and install all in-wall blocking/backing except that embedded in concrete including but not limited all wall caps, wood plaster screeds, grounds, nailers, stops, plaster expansion joints and moldings, electrical, mechanical, plumbing and reglet flashing, as required for proper installation. Coordinate with respective contractors for elevations.
3. Furnish and install all plywood for interior wall finishes.
4. Furnish and install all exterior plywood complete.
5. Furnish and install all framing and plywood at transformers, electrical panels, and equipment supports.
6. Furnish and install all plywood substrates for interior wall finishes including wood shims at beams/columns to align with adjacent materials.
7. Furnish and install all drilling of holes for own installations.
8. Physically layout and install all block outs, openings, reinforcing and bracing from written layout provided by other contractors.
9. Furnish and install tapered nailer at top of plaster.
10. Furnish and install all tapered nailers at top of steel for wood framing attachment.
11. Furnish and install all framing for architectural access doors shown in the architectural drawings at hard ceilings, soffits, and walls other than utility access doors.
12. Furnish and install framing hardware including but not limited to:
 - a. Simpson hardware, hold downs, washers, nuts, hangers, stiffeners, straps, etc. Concrete Bid Package to install Simpson hardware embedded in concrete provided F.O.B. from this bid package.
13. Furnish and install all wall prep for wall framing out of tolerance.
14. Furnish and install wood backing for roof ladder per 5/A880 & 20/A880. **(ADM 5)**
15. Furnish and install wood backing for pipes on roof per 2/P800.
16. Furnish and install Bumper Boards at Trash Enclosures per 19/A105.
17. Furnish and install plywood substrate at stainless steel countertop at coiling door opening. Install countertop support brackets provided FOB by steel package.
18. Furnish and install all backing and supports for OFCI items.
19. Furnish and install all wood fillers at structural steel necessary to provide flush finish with adjacent material as shown throughout the drawings.
20. Furnish and install all bolts and hardware necessary to attach wood to steel members/plates/etc.
21. Furnish and install wood chase wall behind lab casework for utility rough in per 28/A211.

22. Provide caps/impalement protection for any impalement hazards such as concrete stakes, rebar, bolts, conduit, pipe, etc. Protection shall remain in place until impalement hazard is eliminated.
23. **Furnish and install continuous 2x4 at soffit/wall framing per 26/S008. (ADM 5)**

FOB Items

1. Provide concrete package with bolts and washers for hold downs and sill plates. Provide physical layout.
2. Furnish FOB all sill bolts, hold down anchors, etc.
3. Provide concrete package with all Simpson Hardware embedded in concrete. Provide physical layout.

Installation of FOB Items

Note. Unload, inventory, store and notify of deficiencies for all items delivered to the jobsite FOB, to be installed by this subcontractor:

1. Install all steel provided FOB from Steel contractor that is to be attached to wood. Reference Steel Bid Package scope of work.
2. Install bolts/washers/nuts provided FOB by steel contractor.
3. Install counter support brackets

End of Bid Package

DOE-06 – Casework

Furnish and install all work specifically required throughout the project documents to complete the work of this bid package that specifically includes, but is not limited to the following:

Specification Sections

Division 00	General Conditions for Contracts on Construction Management Projects
Division 01	General Requirements
03 15 12	Post Installed Concrete Anchors (as applies to this bid package)
05 50 00	Metal Fabrications (as applies to this bid package)
06 41 16	Plastic Laminate Casework
06 41 18	Solid Surface Countertops
07 92 00	Joint Sealants
11 53 13	Laboratory Fume Hoods
12 36 63	Epoxy Resin Laboratory Countertops

Refer to additional related specifications sections for work specifically included in this bid package noted below.

General Items

1. Provide all clean up and provide off-haul of own debris from site.
2. See General Notes at beginning of summary of work specification section for other items.
3. Construction water will be available at the Fire Hydrant located on Herndon Ave (Contractor to verify). Each Bid Package will be responsible for providing their own water meter for water consumption.

Coordination with Other Trades

1. Due to schedule constraints field measuring should be considered at wood framing stage in lieu of after all drywall and finishes are complete. Review the schedule to determine necessity relative to fabrication times. If measurement is required at the framing stage, provide measurement to meet the schedule and figure all associated finishes.
2. Coordinate at the jobsite all plumbing and electrical locations during rough-in activities to assure proper fit at time of casework and equipment installation.
3. Confirm ADA clearance for knee space at sink closure panels.
4. Coordinate with Building Plumbing Bid Package for sink openings in countertops.
5. Confirm cabinet lock and keyway with school district and CM.

Furnish and Install Items

1. Furnish and install all openings in casework and tops for other trades.
2. Furnish and install cable holes and grommets as laid out by District.
3. Furnish and install all floor anchorage, angles, and floor blocking for casework. Backing in wall to be provided by the Framing Bid Package.
4. Furnish and install rough wood carpentry framing incorporated into casework.
5. Furnish and install all attachment of all equipment related to this scope of work.
6. Furnish and install wood walls incorporated into casework.
7. Furnish and install epoxy resin countertop and backsplash.
8. Furnish and install fume hood with steel base cabinets per 24/A211 including steel angle per 25/A211.
9. Furnish and install all Lab Science Equipment per 22/A211.
10. Furnish and install window sills and trim.
11. Furnish and install Stainless steel trim at base per Detail 27/A861.
12. Furnish and install exposed 2x ledger per 10/A861.
13. Furnish and install reception casework complete including incorporated 2x framed walls. Framed walls shown on floor plans with symbols indicating wall types per wall legend will be framed by the framing package. All framing incorporated in reception casework will be furnished and installed by this package.
14. Furnish and install incorporated cable tray in casework as shown. Include access doors routing of wiring.
15. Furnish and install casework and wood trim, including but not limited to:
 - a. Casework shelving units, cabinets, desks, reception desks.
 - b. Solid surface countertops, plastic laminate countertops. Coordinate with framing contractor for locations of supports at countertops.

FOB Items

1. None.

Installation of FOB Items

1. Install all steel support brackets provided F.O.B. by the steel bid package. Attach column brackets to concrete floors with bolted connection.

End of Bid Package

DOE-07 – Drywall, Lath, Plaster, Metal Framing

Furnish and install all work specifically required throughout the project documents to complete the work of this bid package that specifically includes, but is not limited to the following:

Specification Sections

Division 00	General Conditions for Contracts on Construction Management Projects
Division 01	General Requirements
06 16 43	Exterior Gypsum Sheathing
07 25 00	Weather Resistive Barriers
07 62 20	Sheet Metal Flashing and Trim
07 92 00	Joint Sealants
09 22 16	Non-Structural Metal Framing
09 24 00	Portland Cement Plastering
09 29 00	Gypsum Board

Refer to additional related specifications sections for work specifically included in this bid package noted below.

General Items

1. Provide permits for scaffolding as required.
2. There will be one wash-out area for each bid package as designated by the Construction Manager. Provide wash out for own installations.
3. Construction water will be available at the Fire Hydrant located on Herndon Ave (Contractor to verify). Each Bid Package will be responsible for providing their own water meter for water consumption.
4. Furnish clean up daily and off-haul of all debris generated by this bid package.
5. See General Notes at beginning of summary of work specification section for other items.

Coordination with Other Trades

1. Coordinate all drawings with the drawings of other bid package. Note conflicts and provide potential solutions to the architect for review. Coordination must occur prior to installation of the work. Attend all coordination meetings required to coordinate all underground and above ceiling work.
2. Physically layout and install all drilling, block outs, openings, holes, etc....from written layout provided by other contractors for installation of their work.
3. Coordinate locations of window and door frames installed other bid packages relative to the location of plaster molding adjacent to the frames to insure a good fit. Window Package to provide physical layout to the plaster bid package for the plaster molding should windows not arrive prior to plaster j mold installation.
4. Provide a plaster control and expansion joint layout for architect approval prior to installation.
5. Coordinate and provide wall flatness with wall finish trades to comply with product installation standards.
6. Provide building access through scaffold during construction.

Furnish and Install Items

1. Furnish and install all metal framing, drywall, taping/texturing, cement board, plaster and sealant systems as called for in the contract documents.
2. Furnish and install all cement board and moisture resistant drywall.
3. Furnish and install sheetrock for fire rated assemblies at general specialty, electrical, plumbing, and mechanical utilities, and fixtures.
4. Furnish and install signage per CBC 703.7 marking and identification at all rated walls.
5. Furnish and install ALL weather resistive barrier at entire building compete including behind metal panels. Refer to drawings for locations where multiple layers occur.
6. Furnish and install all furring including metal hat channel, Z channel closures. Etc at all furred plaster locations.
7. Furnish and install all reveal metal at plaster.
8. Furnish and install all clips for framing to attach to steel.
9. Furnish and install 3/16" less thickness drywall over plumbing fixture support plates to create flush wall.
10. Furnish and install primer coat at gypsum board as called for in the specifications. Confirm all primer is compatible with final finish system.
11. Furnish and install J metal at door and window openings horizontal and vertical.
12. Furnish and install all sealant as noted above, in addition to the following is a list of specific items:
 - a. all sealant at plaster & gyp board to other material transitions.
 - b. all sealant at fire rated walls for perimeter and framing penetrations. Fire caulking for utility penetrations by MEPF contractors.
13. Furnish and install metal stud backing for mop racks per 13/A860.
14. Furnish and install backing plates for wall TV mounts per 12/A860.
15. Furnish and install all plaster screeds, reveals, vents and plaster accessories as called for.
16. Furnish and install plaster under flashing edge as detailed and scheduled.
17. Furnish and install all lath and plaster. Coordinate levelness and planes with Rough Carpentry bid package.
18. Furnish, install, and remove scaffolding for own installations.
 - a. Provide daily inspection and provide indemnity for use of scaffold by other contractors.
19. Furnish and install temporary heat and fans as needed for taping/texture activities to meet project schedule.
20. Protect and keep floors clean through completion of work.
21. Furnish and install metal stud backing for electrical panels being surface mounted on metal stud walls.
22. Furnish and install all canopy roof metal framing. Coordinate with Structural Steel and Rough Carpentry Bid Packages.
23. Furnish and install all Simpson hardware required for attachment to wood framing.
24. Provide caps/impalement protection for any impalement hazards such as concrete stakes, rebar, bolts, conduit, pipe, etc. Protection shall remain in place until impalement hazard is eliminated.

FOB Items

1. None.

Installation of FOB Items

1. None.

End of Bid Package

DOE-08 - Glass, Glazing, & Storefronts

Furnish and install all work specifically required throughout the project documents to complete the work of this prime-contractor that specifically includes, but is not limited to the following:

Specification Sections

Division 00	General Conditions for Contracts on Construction Management Projects
Division 01	General Requirements
07 62 00	Sheet Metal Flashing and Trim (as applies to this bid package)
07 92 00	Joint Sealants (as applies to this bid package)
08 41 13	Aluminum-Framed Entrances and Storefronts
08 43 33	Aluminum-Framed Folding Glass Storefront
08 44 13	Glazed Aluminum Curtain Walls
08 71 00	Door Hardware (as applies to this bid package)
08 80 00	Glazing

Refer to additional related specifications sections for work specifically included in this bid package noted below.

General Items

1. Any substitution of details or materials must be pre-approved by the Architect, engineers, and DSA. All substitution requests must be submitted to construction manager prior to bid. This contractor is responsible for all costs and time delays required for DSA approval.
2. Furnish clean up daily and off-haul of all debris generated by this bid package.
3. Construction water will be available at the Fire Hydrant located on Herndon Ave (Contractor to verify). Each Bid Package will be responsible for providing their own water meter for water consumption.
4. See General Notes at beginning of summary of work specification section for other items.

Coordination with Other Trades

1. Coordinate locations of window and door frames installed by this prime-contractor relative to the location of plaster molding and drywall termination adjacent to the frames to insure a good fit. Provide physical layout for the plaster /drywall contractor for the plaster molding and drywall. This will allow for work to proceed if frames are not available.
2. Submit shop drawings & procure material so as not to delay the scheduled installation of plaster and drywall.
3. Order windows based on guaranteed rough opening dimensions from the framing contractors.
4. Confirm keyway with school district and Construction Manager.

Furnish and Install Items

1. Provide all design required for deferred approval by DSA.
2. Furnish and install all glass and glazing shown throughout the contract documents.
3. Furnish and install all curtain wall, storefront and alum windows systems complete.
4. Furnish and install glass at door lights. Remove and reinstall screws for stops.
5. Furnish and install operable Nanawall systems complete. Coordinate channel in concrete with concrete contractor.
6. Furnish and install sealants at all aluminum windows and storefront at interior and exterior. This includes windows to flashing, windows to plaster and flashing to plaster.
7. Furnish and install all aluminum flashing, break metal, and flexible flashings as required to provide a complete water tight system.
8. Furnish and install all reinforcing for the storefront system as required by DSA.
9. Furnish and install all hardware for aluminum storefront doors and frames.
10. Provide all water testing of windows per the specifications.
11. Provide 1 mockup in coordination with the plaster, and sheet metal bid package to confirm all flashing and sealant systems.
12. Furnish and install wood shim spacers at storefronts per details on A830.
13. Furnish and install ram board covers at all vertical aluminum jambs for protection of frames during construction.
14. Furnish and install privacy film where required.
15. Furnish and install plywood closures at all aluminum doors and windows if material does not arrive to site prior to building closing for security and weather intrusion.
16. Furnish and install stainless steel trim per details on A822.
17. **Furnish and install door hardware for aluminum storefront systems. Make physical connection to low voltage cabling provided by electrical bid package. (ADM 5)**

FOB Items

1. None.

Installation of FOB Items

1. None.

End of Bid Package

DOE-09 – PVC Roofing, Metal Wall Panel, & Sheet Metal Flashing

Furnish and install all work specifically required throughout the project documents to complete the work of this bid package that specifically includes, but is not limited to the following:

Specification Sections

Division 00	General Conditions for Contracts on Construction Management Projects
Division 01	General Requirements
07 42 00	Custom Perforated Metal Panels (ADM 5)
07 46 00	Aluminum Siding
07 54 19	Thermoplastic (PVC) Membrane Roofing
07 62 00	Sheet Metal Flashing and Trim
07 92 00	Joint Sealants

Refer to additional related specifications sections for work specifically included in this bid package noted below.

General Items

1. Furnish clean up daily and off-haul of all debris generated by this bid package.
2. Provide all hoisting/rigging for work in this bid package.
3. Provide protection of roof for any work related to this bid package after finished roof is complete.
4. Construction water will be available at the Fire Hydrant located on Herndon Ave (Contractor to verify). Each Bid Package will be responsible for providing their own water meter for water consumption.
5. See General Notes at beginning of summary of work specification section for other items.

Coordination with Other Trades

1. Coordinate flashings furnished and installed by Windows/Storefronts Bid Package.
2. Coordinate outlets for building gutters with steel and/or plumbing bid packages for continuation of downspouts.
3. This contractor shall confirm and coordinate all dimensions for roofing. Procure all related information so as not to delay installations as scheduled in the project baseline schedule.
4. Coordinate reglet and termination bar installation with framing contractor for backing locations.
5. Coordinate transitions from plaster to wall/soffit panels with plaster contractor for sequencing of wall air barriers/moisture barriers.

Furnish and Install Items

1. Furnish and install PVC roofing and membrane roofing systems complete including but not limited to:
 - a. All rigid insulation, cover board, crickets, slope system, and air barrier and roofing system over wood deck, walk pads. Flash/tie roofing into roof drains installed by plumbing contractor.
 - b. Cant strips and crickets at roof access hatches, equipment curbs and platforms.
2. Furnish and install all metal gutters.
3. Furnish and install all coping.
4. Furnish and install all penetration flashings, metal flashings, flexible flashings, scupper flashings, mechanical platform covers, skirt flashings, and storm collars including lead and sheet metal at roof including roof drains related and adjacent to the roofing material. Aluminum and break metal flashing at aluminum storefront doors and aluminum windows to be furnished and installed by the Glass, Glazing, and Storefronts Bid Package. All other exterior flashings are to be furnished and installed by this package.
5. Furnish and install collar flashing at HSS beams prior to lath per 2/A891.
6. Furnish and install aluminum cover plate at column penetrations per 14/A891.
7. Furnish and install prefinished color matched flashing where adjacent to metal panels.
8. Furnish and install sheet metal caps for pipe supports on roof per 2/P800.
9. Furnish and install all aluminum siding, metal soffit panels, backing, hat channel, and associated flashings complete. Coordinate with Rough Carpentry Bid Package for

plywood substrate and Metal Framing Bid Package for plaster transitions and metal joist layout at soffit panels. Weather barrier at metal panels will be furnished installed by the plaster contractor. This package shall review and accept weather barrier installation at panels prior to installing your own work.

FOB Items

1. Furnish roof penetration flashings/boots from quantities provided by MEP bid packages after bid.

Installation of FOB Items Note.

1. None.

End of Bid Package

DOE-10 – Acoustical Ceilings & Wallcoverings

Furnish and install all work specifically required throughout the project documents to complete the work of this bid package that specifically includes, but is not limited to the following:

Specification Sections

Division 00	General Conditions for Contracts on Construction Management Projects
Division 01	General Requirements
06 64 00	Fiberglass Reinforced Plastic Paneling
07 92 00	Joint Sealants (as applies to this bid package)
09 51 13	Acoustical Panel Ceilings
09 77 23	Vinyl Covered Tackboard Panels
10 26 00	Wall Protection

Refer to additional related specifications sections for work specifically included in this bid package noted below.

General Items

1. Furnish clean up daily and off-haul of all debris generated by this bid package.
2. See General Notes at beginning of summary of work specification section for other items.
3. Construction water will be available at the Fire Hydrant located on Herndon Ave (Contractor to verify). Each Bid Package will be responsible for providing their own water meter for water consumption.

Coordination with Other Trades

1. Review buildings prior to installation of ceilings to note conflicts with ceiling heights.
2. Coordinate locations for light wires with electrical contractor.
3. Coordinate backing locations for wall metal trim with framing and drywall contractors.

Furnish and Install Items

1. Furnish and install acoustical ceiling systems complete.
2. Furnish and install all hangers, supports and bracing necessary for installation of work included in this bid package.

3. Furnish and install all hanger wires for light fixtures/cable trays in suspended acoustical ceilings. Electrical bid package will connect wire to their work.
4. Furnish and install ceiling tile at electrical & low voltage devices prior to dropping of tile activity. Cut holes in tiles for devices per as required.
5. Furnish and install all FRP and tackboard wall coverings.
6. Furnish and install filler strip below tackboard behind floor base.
7. Furnish and Install sealant at all locations where tackboard meets other materials.
8. Furnish and install cornerguards complete.

FOB Items

1. None.

Installation of FOB Items

1. None.

End of Bid Package

DOE-11 – Painting

Furnish and install all work specifically required throughout the project documents to complete the work of this bid package that specifically includes, but is not limited to the following:

Specification Sections

Division 00	General Conditions for Contracts on Construction Management Projects
Division 01	General Requirements
03 35 43	Polished Concrete Finishing
07 92 00	Joint Sealants
09 67 23	Resinous Flooring
09 91 00	Painting

Refer to additional related specifications sections for work specifically included in this bid package noted below.

General Items

1. Furnish clean up daily and off-haul of all debris generated by this bid package.
2. There will be one wash-out area for each bid package as designated by the Construction Manager. This bid package will be responsible for removal from the site of all debris and spoils generated by this bid package.
3. Construction water will be available at the Fire Hydrant located on Herndon Ave (Contractor to verify). Each Bid Package will be responsible for providing their own water meter for water consumption.
4. See General Notes at beginning of summary of work specification section for other items.

Coordination with Other Trades

1. Schedule paint coats to allow for completion of work with minimal damage with final coat being installed with majority of work completed.

2. Plaster Bid package shall coordinate with Painting Bid Package the application of the cement plaster painting system and provide written report of the cement plaster pH prior to the painting application.

Furnish and Install Items

1. Furnish and install all painting as shown including but not limited to:
 - a. Exposed steel, drywall, exposed plywood, exposed wood/steel roof framing, ceiling scrim, flashings, coping, scuppers, downspouts, canopy decking, hollow metal door/frames. Refer to color schedule for all interior colors.
 - b. Mechanical, plumbing, fire sprinklers, and electrical utilities as required.
 - c. Fire department connection per I/CX2.1.
 - d. Fire resistant painted surfaces.
 - e. All gates to be painted per detail 16/A111.
 - f. 1"x1" continuous metal trim where insulation meets wall. (ADM 5)**
2. Furnish and install sealing systems complete for the project except for concrete floor sealer.
3. Furnish and install Polished Concrete system complete. Coordinate with concrete bid package for floor flatness requirements. Provide floor protection at all polished concrete areas. This shall occur both at completion of concrete installation and immediately upon completion of polished concrete activity. Include 16 hours of maintenance time to repair any issues with floor protection. This package shall also pick up floor protection prior to polished concrete activity and at completion of project. Floor protection shall consist of ram board and plywood/masonite with all joints taped for a smooth finish.
4. Furnish and install finish as specified for trim, doors, and millwork.
5. Furnish and install sealing of masonry and concrete other than slab on grade floors as specified. Floor sealer to be installed by the concrete bid package.
6. Furnish and install all surface preparation and finish of all flashing to be painted. Verify compatibility for primer adhesion at structural steel.
7. Apply painting coats to minimize the need for touch up. Furnish and install all touch up painting required. Touch-up door/window light stops after installation of glazing.
8. Furnish and install floor prep for concrete cracking, filler, saw cut joints and construction joints.
9. Furnish and install all caulking of interior/exterior Hollow Metal Frames.
10. Furnish and install resinous flooring complete including prep. Install, maintain, and remove durable floor protection after flooring is installed until completion of project.
11. Furnish and install Logo in polished concrete floor.

FOB Items

1. None.

Installation of FOB Items

1. None.

End of Bid Package

DOE-12 – General Specialties

Furnish and install all work specifically required throughout the project documents to complete the work of this bid package that specifically includes, but is not limited to the following:

Specification Sections

Division 00	General Conditions for Contracts on Construction Management Projects
Division 01	General Requirements
02 30 00	Subsurface Investigation
03 15 12	Post Installed Concrete Anchors (as applies to this bid package)
04 22 00	Concrete Unit Masonry
07 21 16	Blanket Insulation
07 42 00	Custom Perforated Metal Panels (ADM 5)
07 72 33	Roof Hatch
07 84 13	Penetration Firestopping (as applies to this bid package)
07 92 00	Joint Sealants (as applies to this bid package)
08 10 53	Door Louver and Lite Frames
08 11 13	Hollow Metal Doors and Frames
08 14 16	Flush Wood Doors
08 31 13	Access Doors and Frames
08 33 13	Coiling Counter Doors
08 71 00	Door Hardware (as applies to this bid package)
09 30 00	Tiling
09 60 01	Flooring Moisture and pH Testing
09 65 13	Resilient Base and Accessories
09 65 17	Resilient Rubber Sheet Flooring (ADM 5)
09 65 19	Resilient Tile Flooring (ADM 5)
09 68 16	Carpeting
10 11 16	Markerboards
10 14 00	Signage
10 14 05	Dimensional Sign Characters
10 21 13	Toilet Compartments
10 22 38	Operable Panel Partitions
10 28 00	Toilet Accessories
10 44 15	Fire Extinguishers and Cabinets
10 75 16	Flagpoles
11 01 13	Owner-Furnished, Contractor-Installed Equipment
11 52 13	Projection Screens
32 31 13	Chain Link Fences and Gates
32 31 19	Decorative Metal Fences and Gates
32 33 13	Bicycle Racks

Refer to additional related specifications sections for work specifically included in this bid package noted below.

General Items

1. There will be one wash-out area for each bid package as designated by the Construction Manager. Each bid package will be responsible for removal from the site of all debris and spoils generated by each bid package.
2. Construction water will be available at the Fire Hydrant located on Herndon Ave (Contractor to verify). Each Bid Package will be responsible for providing their own water meter for water consumption.
3. Furnish and install all hangers, supports and bracing necessary for installation of work included in this bid package.
4. Provide all backfill of excavations to original sub-grade for work included in this bid package.
5. Provide early startup / use of equipment included in this bid package as required by the Construction Manager for construction or building systems testing of buildings prior to final acceptance, which will not initiate the warranty period until the filing notice of completion.
6. Any holes through materials to allow installation of utilities not called for in the contract documents shall be installed and reinforced by this bid package.
7. Provide all clean up and provide off-haul of own debris from site.
8. Provide all hoisting/rigging for work in this bid package.
9. See General Notes at beginning of summary of work specification section for other items.

Coordination with Other Trades

1. Provide coordination drawings for above ceiling work for work related to this bid package. Coordinate all drawings with the drawings of this bid package. Note conflicts and provide potential solutions to the architect for review. Coordination must occur prior to installation of the work. Attend all coordination meetings required to coordinate all underground and above ceiling work.
2. Coordinate all work to provide access to buildings for other trades as scheduled.
3. Coordinate layout of vertical rebar in CMU wall foundations with concrete contractor.
4. Coordinate plumbing and electrical for in-wall electrical and plumbing piping in/through CMU.
5. Coordinate ceramic tile installation with mirror locations.
6. Coordinate ADA clearances for ceramic tile and toilet partitions and accessories. Also coordinate with plumbing bid package for clearances.
7. Coordinate locations of hollow metal door frames installed by this bid package relative to the location of plaster molding adjacent to the frames to insure a good fit. Provide physical layout for the plaster contractor for the plaster molding should windows not arrive prior to plaster j mold installation.
8. Coordinate all embedded fences, posts in foundations at building exterior to be installed at a later time.
9. Install and coordinate block-outs at the site fencing to facilitate installation of fine grading by Earthwork Bid Package. Complete site fencing once fine grading is complete.
10. Protect survey stakes for own work and maintain until installations are complete.
11. This contractor shall confirm and coordinate all dimensions for door frames furnished and installed by this package. Procure all related information so as not to delay installations as scheduled in the project baseline schedule.

12. Coordinate with Rough Carpentry Bid Package and/or Metal Stud Framing Bid Package for backing/blocking needed at miscellaneous specialty installations.
13. Coordinate layout of OFCI items.
14. Coordinate keyways with school district and CM.

General Furnish and Install Items

1. Furnish and install all excavations, and backfill of excavations to original subgrade for work included in this bid package.
2. Furnish and install watertight closures at all gang and individual pipe penetration through exterior walls.
3. Furnish and install all coring or place sleeves for utilities through concrete.
4. Furnish and install all rough-in for all equipment of other bid packages and OFCI items as required by the related specification sections and drawings. Connect to equipment.
5. Furnish and install all roof accessories relative to this bid package's work except flashings, to be provided by the Roofing bid packages.
6. Furnish and install roof hatches complete, including safety railing and post.
7. Furnish and install Unistrut for work included in this bid package.
8. Furnish and install drilling of steel for supports for own work.
9. Furnish and install all shims necessary for plumb installation of work included in this bid package.
10. Furnish and install all sleeves for work passing through masonry and concrete work. Coordinate with respective bid packages.
11. Furnish and install all access doors necessary to provide access to work included in this bid package.
12. Furnish off-haul of all excavation spoils to point onsite as directed for work included in this bid package. Earthwork package to use spoils for completion of import materials. Provide spoils amount for this contract to earthwork bid package within 10 days of award of contract.
13. Furnish and install all attachment of all equipment related to this scope of work.
14. Provide caps/impalement protection for any impalement hazards such as concrete stakes, rebar, bolts, conduit, pipe, etc. Protection shall remain in place until impalement hazard is eliminated.

General FOB Items

1. Furnish FOB hand dryers for connection by the Electrical Bid package.
2. Furnish FOB jobsite all anchor bolts that embed in concrete for installation by that packages. Provide written layout.
3. Furnish FOB all sleeves for all utilities to the concrete package for installation.
4. Furnish FOB all fence hooks and gate tracks embedded in concrete for installation by Concrete Bid Package.
5. Furnish all lead flashings, flashings, and storm collars FOB jobsite required for all roof penetrations related to this scope of work for installation by the roofer.

General Installation of FOB Items

Note. Unload, inventory, store and notify of deficiencies for all items delivered to the jobsite FOB, to be installed by this bid package:

1. Receive, inventory, set and anchor in final position all "Owner Furnished, Contractor Installed" equipment.

Masonry

Furnish and Install Items

1. Furnish and install CMU walls.
2. Furnish and install all masonry rebar. Tie to vertical lap bars embedded in foundations provided by concrete contractor. Coordinate rebar lap with concrete package prior to rebar placement in footing.
3. Furnish and install all expansion joints and sealant complete required by the contract documents in CMU.
4. Furnish and install all cutting of block to match grades at building/site walls.
5. Furnish and install all coring of masonry for this and other bid packages.
6. Furnish and install all special or cut block to match details at special corners and ends of walls.
7. Remove all efflorescence from masonry prior to sealing.
8. Furnish and install coring and grouting of CMU for embedded items.

Building Insulation

Furnish and Install Items

1. Furnish and install all thermal insulation, sound insulation, draft / fire stops, and blankets. Roofing bid package to provide rigid roof insulation.
2. Furnish and install insulation at roof deck voids at top of wall.
3. Furnish and install all fire rated top of wall systems complete.
4. Furnish and install exposed ceiling scrim.
5. ***Furnish and install 1"x1" continuous metal trim (painted) where insulation meets wall. Painting will be provided by painting bid package. (ADM 5)***

Hollow Metal Doors & Frames, Access Doors, Coiling Counter Doors, & Door Hardware

Furnish and Install Items

1. Furnish and install coiling counter doors and hardware including frames, and door guides for the coiling doors.
2. Provide additional fusible links for testing of roll up doors and smoke vents.
3. Furnish and install door stops and hold opens at concrete including coring and grouting.
4. Furnish and install all Hollow Metal doors, frames, louvers, anchor clips, and hardware and accessories complete. Provide construction cylinders for temporary use and final keying prior to occupancy by Owner. This contract is responsible for swapping out construction cores with final cores.
5. Furnish and install solid grout bottom 1'-0" minimum of exterior hollow metal frame jambs per 23/A820.
6. Allow temporary use and provide required maintenance of openings after installation of doors and windows provided by this package.
7. ***Furnish and install door hardware as specified for all hollow metal doors and frames. Make physical connection to low voltage cabling provided by electrical bid package. (ADM 5)***

Flooring

Furnish and Install Items

1. Furnish and install floor prep for concrete cracking, saw cut joints and construction joints. Leveling to be provided by the concrete contractor as necessary for areas out of specified concrete standards tolerance. Level concrete within tolerance as required.
2. Confirm that moisture levels of slab on grade meet manufacturer's requirements prior to installation of flooring.
3. Furnish and install all flooring except concrete sealer hardener and resinous flooring. Protect after installation. Carpet to be OFCI.

Ceramic Tile

Furnish and Install Items

1. Furnish and install ceramic tile walls and floors including mortar bed. Concrete and wall substrate contractors shall provide surface flatness within their respective industry standards. Level concrete and wall substrate within tolerance as required for own installations.
2. Test moisture levels of slab on grade meet manufacturer's requirements prior to installation of flooring.
3. Furnish & install all grout and floor sealers for this scope of work.
4. Furnish and install all prep of cement board complete for tile installation.
5. Provide color matched caulk from wall tile to door frame.

Specialties

Furnish and Install Items

1. Furnish and install all roof hatches.
2. Furnish and install ceiling hatches/doors as shown on architectural sheets.
3. Furnish and install all toilet partitions and accessories. See specifications for items to be provided by Owner (OFCI).
4. Furnish and install all TV mounting brackets.
5. Furnish and install site specialties including but not limited to:
 - a. police/fire dept by-pass lock (Knox Box)
 - ~~b. Mailbox (ADM 5)~~
 - c. Flagpoles – Base to be installed by Concrete Bid Package.
6. Furnish and install fire extinguishers and extinguisher cabinets.
7. Furnish and install markerboards.
8. Furnish and install operable partitions complete. Furnish and install all lateral bracing for partition wall including angle iron. Coordinate holes in beam with Structural Steel Package during fabrication.
9. **Furnish and install all projection screens. (ADM 5)**

Signage

Furnish and Install Items

1. Furnish and install all building signage complete.
2. Furnish and install all building aluminum letters and entrance sign aluminum letters.
3. Furnish and install "This Door to Remain Unlocked When This Space is Occupied" per Remark A on A700.
4. Furnish and install Cast Metal Signage Letters per 22/A891 including continuous SS C-channel for mounting.

Fencing

Furnish and Install Items

1. Furnish and install excavations for fence posts.
2. Furnish and install all chain link and ornamental fence as shown.
3. Furnish and install complete fence/gate system as shown on sheet A261. Include excavations, tube steel structure, gate, perforated panels, hardware, etc.
4. Furnish and install all site fencing, gates, and hardware complete. Prep all gates as needed to accept required hardware.
5. Furnish and install all cane bolts including drilling holes.
6. Furnish and install all fence enclosures including chain link roofs as shown.
7. Furnish and install gates and hardware complete at trash enclosures.
8. Furnish and install backfill of fence post excavations to the required grade and off-haul spoils.
9. Confirm keyway with CUSD.

Playground Equipment

Furnish and Install Items

1. Furnish and install all playground equipment complete including excavations, foundations, sand/gravel cushion, rubber surface. Concrete under rubber surface to be provided by concrete package.

End of Bid Package

DOE-13 – Fire Sprinklers

Furnish and install all work specifically required throughout the project documents to complete the work of this bid package that specifically includes, but is not limited to the following:

Specification Sections

Division 00	General Conditions for Contracts on Construction Management Projects
Division 01	General Requirements
03 15 12	Post Installed Concrete Anchors (as applies to this bid package)
07 84 13	Penetration Firestopping (as applies to this bid package)
07 92 00	Joint Sealants (as applies to this bid package)
08 31 13	Access Doors and Frames (as applies to this bid package)
21 00 00	Fire Sprinkler Systems
23 01 00	General Mechanical Provisions (as applies to this bid package)

Refer to additional related specifications sections for work specifically included in this bid package noted below.

General Items

1. Any holes through materials to allow installation of utilities not called for in the contract documents shall be installed and reinforced by this bid package.
2. Provide all clean up and provide off-haul of own debris from site.

3. Construction water will be available at the Fire Hydrant located on Herndon Ave (Contractor to verify). Each Bid Package will be responsible for providing their own water meter for water consumption.
4. Provide all hoisting/rigging for work in this bid package.
5. Provide early startup / use of fire sprinkler system as required by the Construction Manager for construction or building systems testing of buildings prior to final acceptance, which will not initiate the warranty period until the filing notice of completion.
6. See General Notes at beginning of summary of work specification section for other items.

Coordination with Other Trades

1. Provide coordination drawings for above ceiling work for work related to this bid package. Coordinate all drawings with the drawings of this bid package. Note conflicts and provide potential solutions to the architect for review. Coordination must occur prior to installation of the work. Attend all coordination meetings required to coordinate all underground and above ceiling work.
2. Coordinate all work to provide access to buildings for other trades as scheduled. Provide a breakout schedule of where and when piping operations will be performed that has been coordinated with other activities in the schedule for other trades.
3. Purging and testing of all building fire sprinkler utilities included in this bid package is the responsibility of this bid package. Coordinate with site utility contractor prior to connection.
4. Coordinate hook up of electrical and low voltage wiring with related bid package.
5. Provide location of stub for the underground contractor.
6. Provide written layout to framing contractor prior to framing for location of all backing/blocking for own installations. Any missed layout not provided to the framing contractor shall be furnished and installed by this contractor.

Furnish and Install Items

1. Install all coring or place sleeves for utilities through concrete.
2. Furnish and install building fire sprinkler system per plan for a complete system.
3. Furnish and install all signage/labelling required for this scope of work.
4. Furnish and install all exposed materials in a consistent and aesthetic manner.
5. Furnish and install all access doors necessary to provide access to work included in this bid package.
6. Furnish and install all attachment of all equipment related to this scope of work.
7. Furnish and install all hangers, supports, and bracing necessary for installation of work included in this bid package.
8. Furnish and install fire stopping related to this scope of work. Coordinate system with other MEP trades to comply with specifications.
9. Furnish and install complete fire sprinkler risers, from flange, at buildings per Detail 1/FP800. Electrical contractor to connect to electric bell and flow switch installed by this contractor.
10. Furnish and install drilling of steel or wood for supports and piping installations.

FOB Items

1. None.

Installation of FOB Items

1. None.

End of Bid Package

DOE-14 - Building Plumbing

Furnish and install all work specifically required throughout the project documents to complete the work of this bid package that specifically includes, but is not limited to the following:

Specification Sections

Division 00	General Conditions for Contracts on Construction Management Projects
Division 01	General Requirements
03 15 12	Post Installed Concrete Anchors (as applies to this bid package)
07 84 13	Penetration Firestopping (as applies to this bid package)
07 92 00	Joint Sealants (as applies to this bid package)
08 31 13	Access Doors and Frames (as applies to this bid package)
11 01 13	Owner-Furnished, Contractor-Installed Equipment (as applies to this bid package)
22 00 00	General Plumbing Provisions
22 00 50	Plumbing
23 01 00	General Mechanical Provisions (as applies to this bid package)
31 22 22	Soil Materials
31 23 33	Trench Excavation and Backfill
31 50 00	Excavation Support and Protection
Geotechnical Report	

Refer to additional related specifications sections for work specifically included in this bid package noted below.

General Items

1. Furnish off-haul of all excavation spoils to point onsite as directed for work included in this bid package. Earthwork package to use spoils for completion of import materials. Provide spoils amount for this contract to Earthwork bid package within 10 days of award of contract.
2. Provide dewatering for own excavations.
3. Construction water will be available at the Fire Hydrant located on Herndon Ave (Contractor to verify). Each Bid Package will be responsible for providing their own water meter for water consumption.
4. There will be one wash-out area for each bid package as designated by the Construction Manager. Each bid package will be responsible for removal from the site of all debris and spoils generated by each bid package.
5. Provide all backfill of excavations to original subgrade for work included in this bid package.
6. Provide early startup / use of plumbing equipment as required by the Construction Manager for construction or building systems testing of buildings prior to final

- acceptance, which will not initiate the warranty period until the filing notice of completion.
7. Any holes through materials to allow installation of utilities not called for in the contract documents shall be installed and reinforced by this bid package.
 8. Provide all clean up and provide off hauls of own debris from site.
 9. Provide all hoisting/rigging for work in this bid package.
 10. See General Notes at beginning of summary of work specification section for other items.

Coordination with Other Trades

1. Provide coordination drawings for underground and above ceiling work for work related to this bid package. Coordinate all drawings with the drawings of this bid package. Note conflicts and provide potential solutions to the architect for review. Coordination must occur prior to excavation and/or installation of the work. Attend all coordination meetings required to coordinate all underground and above ceiling work.
2. Provide dimensions for structural openings through building structure.
3. Coordinate all work to provide access to buildings for other trades as scheduled. Provide a breakout schedule of where and when piping operations will be performed that has been coordinated with other activities in the schedule for other trades.
4. This bid package shall make physical connections from buildings to site utilities.
5. Cleaning and purging of all building plumbing utilities included in this bid package is the responsibility of this bid package. Coordinate with site utility contractor prior to connection.
6. Clean and disinfect all building piping. Phased construction will necessitate a specific schedule of disinfection coordinated with the packages. Create disinfection plan and coordinate with site bid package to allow for complete and maintained disinfection of the entire system until acceptance by owner.
7. Coordinate routing of plumbing to miss foundations.
8. Make adjustment and coordinate with concrete contractor for flush installation of exterior boxes for cleanouts, valves, etc.
9. Provide dimensions for wall and roof openings on structural coordination drawings.
10. Coordinate installation of roof drains with roofing contractor for watertight installation.
11. Coordinate the location of depressions, block outs, slopes, and drains with the Concrete Contractor prior to pour.
12. This contractor shall provide pour watch of own installations through building concrete slabs for every scheduled S.O.G. installation by the concrete contractor. This is mandatory.
13. Protect survey stakes for own work and maintain until installations are complete.
14. Provide written layout to framing contractor prior to framing for location of all backing/blocking for own installations. Any missed layout not provided to the framing contractor shall be furnished and installed by this contractor.
15. Provide roof penetration quantities with sizes for roofing contractor.

Furnish and Install Items

1. Furnish and install street cleaning for own scope of work as required.
2. Furnish and install building plumbing systems complete, including but not limited to:

- a. Gas piping, domestic water piping, waste/vent piping, roof drains, condensate drain piping, plumbing fixtures, plumbing equipment, plumbing accessories, etc.
3. Furnish and install physical layout for all deepened foundations at utilities prior to excavation by the concrete bid package.
4. Furnish and install all sleeves in foundations prior to the installation of concrete and reinforcing steel. Coordinate location with other related bid packages prior to excavation.
5. Furnish and install all coring or place sleeves for utilities through masonry and concrete.
6. Furnish and install all excavations and backfill of excavations to original subgrade for work included in this bid package. Certify grades have been returned to original grade when work is complete.
7. Furnish and install all concrete required for installation of thrust blocks for all work related to this bid package.
8. Furnish, install, and maintain protection of work included in this bid package from damage and intrusion of dirt and / or debris into the building piping systems for the length of the project per the SWPPP. Protection shall allow use, as directed by the Construction Manager, of the plumbing utility systems during construction for construction and testing operations without the start of the warranty period until the notice of completion for the project.
9. This bid package is to make final connections to gas shut-off valves within U.G. valve boxes located outside building footprint. Provide all necessary material to complete connections. Shut-off valves and boxes are furnished and installed by Site Utilities Bid Package. Gas Pressure Regulator assemblies are to be furnished and installed complete by this bid package. Purge all gas lines at time of final connection for each building.
10. Furnish, install, and connect all building utilities to 5' from building or noted POC unless otherwise noted in this bid package.
11. Furnish and install utilities feeding the Laboratory Fume Hood. Final connections to the equipment to be by this bid package.
12. Furnish and install roof drains with cleanout and make connection to site storm drain marked and stubbed 5' outside of building by site utility contractor. Provide stainless steel escutcheon at roof overflow daylighting at building exterior.
13. Furnish and install all flues associated with own work.
14. Furnish and install watertight closures at all gang and individual pipe penetration through exterior walls for own work.
15. Furnish and install water heater brackets and platforms complete.
16. Furnish and install all hangers, supports and bracing necessary for installation of work included in this bid package.
17. Furnish and install all attachments of all equipment related to this scope of work.
18. Furnish and install any/all seismic bracing required for work included in this bid package.
19. Furnish and install backing for all plumbing fixtures. Steel plates only, no wood.
20. Furnish and install drilling of steel or wood for supports and piping installations.
21. Furnish and install disinfection of all building plumbing related to this bid package. Coordinate a disinfection plan with other bid packages to assure a clean system at acceptance.
22. Furnish and install all roof accessories relative to this bid package's work.

23. Furnish and install all rough-in for all equipment of other bid packages as required by the related specification sections and drawings. Connect to equipment.
24. Furnish and install all required utilities for Owner Furnished Equipment., capped and ready for connection. Connections to be made by this bid package.
25. Furnish and install all signage/labelling required for this scope of work.
26. Furnish and install all building drinking fountains and associated backing (guard rails by others).
27. Furnish and install all toilet and sink sensors and wiring complete to hook up of power. Conduit is by Electrical Bid Package.
28. Furnish and install clean outs shown on plumbing drawings.
29. Furnish and install sealant at overflow drains.
11. Furnish and install fire stopping related to this scope of work. Coordinate system with other MEP trades to comply with specifications.
30. Furnish and install all access doors necessary to provide access to work included in this bid package.
31. Furnish and install condensate drains. Connect condensate drain to unit pump provided by HVAC contractor and extend in attic to drain.
32. Furnish and install escutcheon covers, rings, etc. at all floor, wall, and ceiling penetrations for plumbing lines and /or fixtures. All floor gaps, holes around lines at penetrations shall be sealed and caulked as per health dept. requirements.
33. Furnish and install sealant and backer material, pipe jackets, escutcheons for own piping penetrations through walls.
34. Furnish and install emergency eye wash/shower.
35. Furnish and install drywell system complete per detail 12/P800
36. Provide testing of floor and roof drains at completion of project.
37. Provide caps/impalement protection for any impalement hazards such as concrete stakes, rebar, bolts, conduit, pipe, etc. Protection shall remain in place until impalement hazard is eliminated.

FOB Items

1. Furnish FOB jobsite all anchor bolts and templates that embed in concrete or masonry for installation by those packages. Provide written layout.

Installation of FOB Items

Note. Unload, inventory, store and notify of deficiencies for all items delivered to the jobsite FOB, to be installed by this bid package:

1. Washer and dryer OFCI.
2. Refrigerator OFCI.

End of Bid Package

DOE-15 - Mechanical

Furnish and install all work specifically required throughout the project documents to complete the work of this bid package that specifically includes, but is not limited to the following:

Specification Sections

Division 00	General Conditions for Contracts on Construction Management Projects
Division 01	General Requirements
03 15 12	Post Installed Concrete Anchors (as applies to this bid package)
07 62 00	Flashing Sheet Metal and Trim (as applies to this bid package)
07 84 13	Penetration Firestopping (as applies to this bid package)
07 92 00	Joint Sealants (as applies to this bid package)
08 31 13	Access Doors and Frames (as applies to this bid package)
23 01 00	General Mechanical Provisions
23 05 00	Common Work Results for HVAC
23 05 13	Common Motor Requirements for HVAC Equipment
23 05 29	Hangers and Supports for HVAC Piping and Equipment
23 05 48	Vibration and Seismic Controls for HVAC Piping and Equipment
23 05 53	Identification for HVAC Piping and Equipment
23 05 93	Testing, Adjusting, and Balancing for HVAC
23 07 00	HVAC Insulation
23 08 00	Commissioning of HVAC
23 31 13	Metal Ducts
23 33 00	Air Duct Accessories
23 34 23	HVAC Power Ventilators
23 37 23	HVAC Gravity Ventilators
23 74 13	Packaged Outdoor Central-Station Air Handling Units
23 81 26	Split System Air Conditioners
25 50 00	Direct Digital Control and Energy Management System

Refer to additional related specifications sections for work specifically included in this bid package noted below.

General Items

1. Provide early startup and maintenance of HVAC equipment as required by the Construction Manager for acclimatization of buildings prior to final acceptance, which will not initiate the warranty period until the filing notice of completion.
2. Any holes through materials to allow installation of utilities not called for in the contract documents shall be installed and reinforced by this bid package.
3. Provide all clean up and off-haul of own debris from site.
4. Construction water will be available at the Fire Hydrant located on Herndon Ave (Contractor to verify). Each Bid Package will be responsible for providing their own water meter for water consumption.
5. Provide all hoisting/rigging for work in this bid package.
6. See General Notes at beginning of summary of work specification section for other items.

Coordination with Other Trades

1. Provide coordination drawings for underground and above ceiling work for work related to this bid package. Coordinate all drawings with the drawings of this bid package. Note conflicts and provide potential solutions to the architect for review. Coordination must occur prior to excavation and/or installation of the work. Attend all coordination meetings required to coordinate all underground and above ceiling work.
2. Provide dimensions for structural openings on framing coordination drawings.
3. Provide physical layout of systems through walls & ceilings/roof for block out by framing contractor.
4. Provide all necessary openings and/or connection points for EMS and fire alarm wiring and devices.
5. Concrete housekeeping and equipment pads will be furnished and installed by the concrete bid package. Provide dimensions for pads.
6. Provide written layout to framing contractor prior to framing for location of all backing/blocking for own installations. Any missed layout not provided to the framing contractor shall be furnished and installed by this contractor.
7. Provide crane access plan and duration of construction to stop during setting the roof top equipment.
8. Provide quantities of roof penetration jacks with sizes for roofing contractor.
9. Provide pre/post commissioning plan for review and acceptance by Owner and CM prior to initiating any commissioning activities.

Furnish and Install Items

1. Furnish and install all HVAC equipment, EMS, ductwork, duct insulation, refrigerant piping, piping, and pipe insulation, fixtures, accessories, controls, and air balance for a complete heating and air conditioning system.
2. Furnish and install all access doors necessary to provide access to work included in this bid package.
3. Furnish and install all attachment of all equipment related to this scope of work.
4. Furnish and install all hangers, supports and bracing necessary for installation of work included in this bid package.
5. Furnish and install any/all seismic bracing required for work included in this bid package.
6. Furnish and install all roof curbs with proper height and slope for the roofing system. Verify heights with roofing shop drawings prior to fabrication.
7. Furnish and install all roof accessories and/or curbs/platforms/stands/supports/steel backing/bolts/angles (pre-manufactured for all mechanical equipment provided under this bid package).
8. Furnish and install all rough-in for all equipment of other bid packages as required by the related specification sections and drawings. Connect and or stub as described.
9. Furnish and install HVAC Controls and/or EMS system complete including conduit and wiring unless specifically called for on electrical drawings.
10. Furnish and install drilling of structure for installation of own supports and piping installations.
12. Furnish and install fire stopping related to this scope of work. Coordinate system with other MEP trades to comply with specifications.
11. Furnish and install all flues associated with own work.

12. Furnish and install all signage, labelling, and lettering called for in the contract documents related to work of this bid package.
13. Provide for testing of Fire Smoke Dampers with resettable link.
14. Furnish and install stainless steel countertop and cased frame at coiling counter door per detail 15/A830.
15. Provide Fire Smoke Dampers ready for power hook up. Provide ceiling access panels for fire damper access. Provide fire rated access panels as required.
16. Furnish and install mechanical unit relays for connection by electrical contractor.
17. Furnish and install fire barrier duct wrap.
18. Furnish and install all stainless steel exhaust duct and accessories serving the Laboratory fume hood. Final connections to the equipment to be by this bid package.
19. Provide start-up and run equipment for acclimation of buildings without effecting official start date of Warranty period upon Owner acceptance of project. Protect all openings to the duct system during this time with filters at all return air openings. Provide final equipment washdown upon completion of dust-generating construction activities.
20. Provide two (2) changes of filters, at all filter locations, for construction dust during construction prior to installation of final filters.
21. Provide pre & post functional testing/commissioning of the HVAC system per specifications. Provide plan to Owner/CM for approval prior to starting any commissioning activities.
22. Provide complete air balance for the HVAC System per specifications.

FOB Items

1. Furnish all starters at HVAC units. Electrical connections shall be made by Electrical Bid Package.
2. Provide FOB jobsite all Fire Smoke Dampers ready for power hook up.
3. Provide mechanical unit relays for connection by electrical contractor.

Installation of FOB Items

1. None.

End of Bid Package

DOE-16 – Electrical & Site Electrical

Furnish and install all work specifically required throughout the project documents to complete the work of this bid package that specifically includes, but is not limited to the following:

Specification Sections

Division 00	General Conditions for Contracts on Construction Management Projects
Division 01	General Requirements
02 30 00	Subsurface Investigation
03 15 12	Post Installed Concrete Anchors (as applies to this bid package)
07 84 13	Penetration Firestopping (as applies to this bid package)
07 92 00	Joint Sealants (as applies to this bid package)
08 31 13	Access Doors and Frames (as applies to this bid package)
11 52 16	Projector Mounts

26 00 00	Summary Electrical Work
26 01 00	General Conditions for Electrical Work
26 05 00	Basic Electrical Materials and Methods
26 05 26	Grounding
26 22 13	Dry-Type Transformers (600V and less)
26 24 13	Switchboards
26 24 16	Panelboards
26 51 13	Lighting
26 61 00	Lighting Control Systems
26 95 00	Electrical Acceptance Tests
27 00 00	Communications General
27 05 28	Communications Infrastructure System
27 10 00	Structured Cabling System
27 20 10	Uninterrupted Power Supply
27 40 40	Assistive Learning Systems
27 42 00	Classroom Audio/Visual Systems
27 53 13	Analog Synchronous Clocks
27 70 00	Intercom/Clock/Public Address System
27 80 00	Video Surveillance
28 31 00	Fire Detection and Alarm
31 22 22	Soils Materials
31 23 33	Trench, Excavation, and Backfill
31 50 00	Excavation Support and Protection
	Geotechnical Report

Refer to additional related specifications sections for work specifically included in this bid package noted below.

General Items

1. Furnish off-haul of all excavation spoils to point onsite as directed for work included in this bid package. Earthwork package to use spoils for completion of import materials. Provide spoils amount for this contract to Earthwork bid package within 10 days of award of contract.
2. Provide dewatering for own excavations.
3. Construction water will be available at the Fire Hydrant located on Herndon Ave (Contractor to verify). Each Bid Package will be responsible for providing their own water meter for water consumption.
4. There will be one wash-out area for each bid package as designated by the Construction Manager. Each bid package will be responsible for removal from the site of all debris and spoils generated by each bid package.
5. Provide trenching plan and permits for excavations over 5' per OSHA requirements to the construction manager.
6. Provide use and maintenance of electrical equipment and devices as required by the construction manager for construction and testing of other equipment prior to final acceptance, which will not initiate the warranty period until filing of notice of completion.
7. Provide all clean up and off-haul of own debris from site.
8. Provide all hoisting/rigging for work in this bid package.

9. See General Notes at beginning of summary of work specification section for other items.

Coordination with Other Trades

1. Provide coordination drawings for underground and above ceiling work for work related to this bid package. Coordinate all drawings with the drawings of this bid package. Note conflicts and provide potential solutions to the architect for review. Coordination must occur prior to excavation and/or installation of the work. Attend all coordination meetings required to coordinate all underground and above ceiling work.
2. Provide shop drawings for equipment layout in electrical yards and electrical rooms to confirm that dimensions are adequate prior to rough in and pouring of foundations.
3. Light pole bases shall be excavated and installed by the Concrete Bid Package. Coordinate the installation and requirements of light pole bases with the Concrete Bid Package.
4. Coordinate with PG&E, Comcast, and AT&T for service requirements to the site.
5. Coordinate all work to provide access to buildings for other trades as scheduled. Provide an underground utility schedule of where and when piping operations will be performed. Coordinate with other activities in the schedule for other trades and confirm the schedule meets the CMBS dates.
6. At conflicts with site utilities, electrical duct banks/conduits are to have the lower elevations.
7. Coordinate location of fire alarm monitoring devices for PIV/tamper switches/flow switches with site utility drawings.
8. Provide physical layout of systems through walls & ceilings/roof for block out by framing contractor Any holes through materials to allow installation of utilities not called for in the contract documents shall be installed and reinforced by this bid package.
9. Quantify, coordinate, and provide final connections of starters for HVAC units as provided by the Mechanical Bid Package.
10. Furnish and install physical layout for all deepened foundations at utilities prior to excavation.
11. Provide layout of all coring to be installed after the fact for installation of reinforcing by the masonry.
12. Coordinate with all underground utilities prior to excavation.
13. This contractor shall provide pour watch of own installations through building concrete slabs for every scheduled S.O.G. installation by the concrete contractor. This is mandatory.
14. Coordinate power and fire alarm connection with roll-up doors.
15. Protect survey stakes for own work and maintain until installations are complete.
16. Provide written layout to framing contractor prior to framing for location of all backing/blocking for own installations. Any missed layout not provided to the framing contractor shall be furnished and installed by this contractor.
17. Verify voltage for all equipment by others from product submittals prior to installation.
18. Coordinate UG utilities out of building's angle of repose.
19. Coordinate TV monitor outlet locations with school district.

Furnish and Install Items

1. Furnish and install all building and site electrical complete.

2. Furnish and install street cleaning for own scope of work as required by municipal ordinance.
3. Furnish and install firestopping for own work. Coordinate system with other MEP trades to comply with specifications.
4. Furnish and install sheet caulk at outlet boxes at sound and fire rated assemblies.
5. Furnish and install all building and site electrical complete.
6. Furnish and install all low voltage systems complete except for the EMS system.
7. Furnish and install pull strings / rope in all empty or future conduits.
8. Furnish and install all concrete required for installation of manholes, vaults, boxes, underground structures, work related to this bid package.
9. Furnish and install all colored concrete cap over all required duct banks.
10. Furnish and install all coring and reinforcing for utilities through concrete and masonry.
11. Any holes through materials to allow installation of utilities not called for in the contract documents shall be installed and reinforced by this bid package.
12. Furnish and install all sleeves for work passing through masonry and concrete work. Coordinate with Respective bid packages.
13. Furnish and install all sleeves in foundations prior to the installation of concrete and reinforcing steel. Coordinate location with other related bid packages prior to excavation.
14. Furnish and install all access doors necessary to provide access to work included in this bid package.
15. Furnish and install all attachment of all equipment related to this scope of work.
16. Provide all backfill of excavations to original subgrade for work included in this bid package.
17. Furnish and install all conduit & sleeves for future low voltage and telecommunications wiring. Install fire stopping as required.
18. Furnish and install disconnects and associated supports.
19. Furnish and install project mounts.
20. Furnish and install all necessary supports required for pendent light fixtures.
21. Furnish and install all supports and bracing required for electrical work except for hanger wires in suspended acoustical ceilings.
22. Furnish and install watertight closures at all gang and individual pipe penetration through exterior walls.
23. Furnish and install all signage and lettering called for in the contract documents related to work of this bid package.
24. Furnish and install pipe bollards/sleeves/foundations as shown at new electrical equipment.
25. Furnish and install utilities feeding the Laboratory Fume Hood. Final connections to the equipment to be by this bid package.
26. Furnish and install all required utilities for Owner Furnished Equipment, hook up as required.
27. Furnish and install all rough-in for all equipment of other bid packages as required by the related specification sections and drawings. Connect and or stub as described.
28. Furnish and install all roof accessories relative to this bid package's work.
29. Furnish and install drilling of structure for supports and piping installations.
30. Furnish and install all roof supports for electrical.
31. Furnish and install all speakers, speaker cloth, associated brackets.
32. Furnish and install all floor boxes solid for install of slab on grade.

33. Furnish and install all interior and exterior floor boxes.
34. Furnish, install, and remove all temp power per Temporary Power Plan. Maintain for duration of project and remove at completion of project. At project startup, provide the following:
 - a. Connect to existing 400A panel. Run (4) 2" conduits from existing panel to (2) locations at each building for a total of (4) locations. Provide all necessary wiring and components for hook up. Provide (1) temporary power box at each conduit location for a total of (4) temporary power boxes.
 - b. Temporary power boxes shall remain in service until completion of project or until permanent power is available at the buildings.
 - c. Provide inspection, testing and maintenance of temporary power system per OSHA regulations. Provide documented inspection report to CM. Secure temporary power boxes from the end of each workday to the start of the next.
35. Furnish, install, and connect power to all equipment including switches and controls.
36. Furnish and install power to landscape controllers.
37. Furnish and install holes in door and window frames for own work.
38. Furnish, install, and maintain traffic control for work included in this bid package.
39. Furnish and install wireless access point data jacks.
40. Furnish and install all components and wiring required to hook-up fire suppression system to fire alarm, exhaust blower, & make-up air system for interlock and shut down.
41. ~~Furnish and install all **OFCI** projectors in ceilings. (ADM 5)~~
42. Furnish and install power and Fire Alarm to fire/smoke damper electric actuators. Provide area smoke detector to control dampers.
43. Raise all existing utility boxes/structures to grade in landscape and concrete paving areas.
44. Rough-in for security and access per Note A requirements on E410 and E420.
45. Pothole existing electrical and communication utilities, mark and maintain markings throughout site.
46. Furnish and install alarm conduit, pull string, and box rough in.
47. Furnish and install Unistrut for paint at exposed ceilings prior to fixture installation.
48. Provide commissioning for electrical work.
49. Furnish and install rough in for future EV charge stations.
50. Furnish and install disconnects not provided on factory equipment installed by other bid packages.
51. Furnish, install, and maintain egress lighting for both buildings. Lighting shall consist of strand lights down all main corridors. Lighting shall be installed at the completion of framing until all permanent lights are installed and operating.
52. Connect "hanger wires" provided by the Acoustical Bid Package to light fixtures.
53. Provide caps/impalement protection for any impalement hazards such as concrete stakes, rebar, bolts, conduit, pipe, etc. Protection shall remain in place until impalement hazard is eliminated.
54. **Furnish and install all projector mounts. (ADM 5)**
55. **Furnish and install low voltage cabling for door hardware. Final electrical connection at hardware to be made by the door hardware installer. (ADM 5)**

FOB Items

1. Furnish FOB jobsite all bolt templates for use by the concrete bid package and masonry bid package.

2. Furnish FOB jobsite all anchor bolts and templates for light poles and equipment.
3. Furnish FOB all sleeves for all utilities to the concrete package for installation.

Installation of FOB Items

Note. Unload, inventory, store and notify of deficiencies for all items delivered to the jobsite FOB, to be installed by this bid package:

1. Install all switches for equipment provided by others.
2. Install hand dryers provided FOB by General Specialties Package.
3. Connect relay module to mechanical unit shutdown. Relays to be provided by HVAC contractor.
4. Connect to electric fire sprinkler bell and flow switch installed by fire protection contractor at building fire risers.

End of Bid Package

DOE-17 – Landscape and Irrigation

Furnish and install all work specifically required throughout the project documents to complete the work of this bid package that specifically includes, but is not limited to the following:

Specification Sections

Division 00	General Conditions for Contracts on Construction Management Projects
Division 01	General Requirements
02 30 00	Subsurface Investigation
31 22 22	Soils Materials
31 23 33	Trench, Excavation, and Backfill
31 50 00	Excavation Support and Protection
32 84 00	Landscape Irrigation System
32 90 00	Landscape Construction
	Geotechnical Report

Refer to additional related specifications sections for work specifically included in this bid package noted below.

General Items

1. Furnish and install all sleeves in masonry, concrete, and foundations prior to the installation of concrete and reinforcing steel. Coordinate location with other related bid packages prior to excavation.
2. Furnish off-haul of all excavation spoils to point onsite as directed for work included in this bid package.
3. There will be one wash-out area for each bid package as designated by the Construction Manager. Each bid package will be responsible for removal from the site of all debris and spoils generated by this bid package.
4. Construction water will be available at the Fire Hydrant located on Herndon Ave (Contractor to verify). Each Bid Package will be responsible for providing their own water meter for water consumption.

5. Owner shall furnish metered water at hydrant located on-site for construction water for this and other prime contractors.
6. See General Notes at beginning of summary of work specification section for other items.

Coordination with Other Trades

1. Provide coordination drawings for underground work related to this bid package. Coordinate all drawings with the drawings of other bid packages. Note conflicts and provide potential solutions to the architect for review. Coordination must occur prior to excavation and/or installation of the work. Attend all coordination meetings required to coordinate all underground and above ceiling work.
2. At conflicts with electrical duct banks, electrical duct banks are to have the lower elevations.
3. Coordinate location of site utility installations with location of building structure foundations to maintain clearance outside the foundation angle of repose.
4. Coordinate with all underground utilities prior to excavation.
5. Receive grades at $\pm .10'$. Cut all additional swales required to provide proper drainage.
6. Protect survey stakes for own work and maintain until installations are complete.

Furnish and Install Items

1. Furnish and install all irrigation and landscaping complete including but not limited to:
 - a. Decomposed granite, ground cover, planting, turf, trees, soil amendments, boulders, cobble stone, and mulch.
 - b. Irrigation system, booster pump, and controls. Connection to irrigation service to be at backflow per landscape drawings. This package to provide all necessary material/fittings to make final connection.
2. Provide final connection to backflow prevention device provided by the site utilities bid package.
3. Furnish and install all irrigation sleeves on separate move-ins.
4. Furnish and install all christy boxes as required for own work.
5. Furnish and install all concrete, concrete collars, and pads for own work except for mow strips.
6. Furnish and install all thrust blocks for own work.
7. Furnish and install all bricks and washed gravel at all boxes as shown.
8. Furnish and install swales beyond that shown on civil drawings for proper drainage.
9. Provide water test of turf and planter areas prior to planting to confirm proper drainage.
10. Maintain project to be weed free until completion.
11. Provide caps/impalement protection for any impalement hazards such as concrete stakes, rebar, bolts, conduit, pipe, etc. Protection shall remain in place until impalement hazard is eliminated.

FOB Items

1. None.

Installation of FOB Items

1. None.

End of Bid Package

1.03 WORK UNDER OTHER CONTRACTS:

1. General Requirements:
 - a. Work under separate contracts will occur throughout the duration of the project. The work being installed under separate contracts will occur around adjacent to the Contract project site including offsite work.
 - b. Contractor shall be responsible for coordinating access to and from the site throughout the duration of the project. Access points to and from the site may vary, based upon timing and duration of separate contracts.
 - c. Contractor shall cooperate and coordinate all work under this Contract with all work under separate contracts.
 - d. Should the Contractor damage and/or otherwise alter work installed under separate contracts, Contractor responsible for the correction repair of work installed under separate contracts.
 - e. Prior to the installation of the Work, coordinate the work installed or to be installed by separate contracts relative to own work.
2. Separate Contracts by Owner:
 - a. Construction Bid Packages, as defined above in Construction Bid Packages.
 - b. Construction Bid Packages as defined in future phases of work below in projected project phasing.
 - c. Owner Furnished Items, as defined in Specification Section – OWNER FURNISHED ITEMS.
3. Separate Contracts by Others:
 - a. Adjacent Properties:
4. Phasing:
5. Phasing is projected to be as shown on the Construction manager's Bid Schedule. However, the owner reserves the right to revise start times pending the review and award of bids.

1.04 CONTRACTOR'S DUTIES:

1. Except as specifically noted, provide, and pay for:
 - a. Labor, material, and equipment.
 - b. Tools, construction equipment and machinery.
 - c. Other facilities and services necessary for proper execution and completion of Work.
 - d. Water: See Specification Section – TEMPORARY FACILITIES AND CONTROLS.
2. Pay legally required sales, consumer and use taxes.
3. Secure and pay for all site specific, as necessary for proper execution and completion of Work, and as applicable at time of receipt of bids.
 - a. Licenses.
 - b. Permits and Fees.
 - c. Governmental Fees.
 - d. Royalties.

4. Give required notices.
5. Comply with codes, ordinances, rules, regulations, orders, and other legal requirements of public authorities which bear on performance of Work.
 - a. The Contractor shall certify in writing that no materials containing Asbestos are incorporated in the work, in accordance with the Asbestos Hazard Emergency Regulations Act.
6. Promptly submit written notice to Construction Manager of observed variance of Contract Documents from legal requirements.
 - a. Appropriate modifications to Contract Documents will adjust necessary changes.
 - b. Assume responsibility for work known to be contrary to such requirements and without written notice to Architect of observed variance.
7. Enforce strict discipline and good order among employees. Do not employ on Work:
 - a. Unfit persons.
 - b. Persons not skilled in assigned task.

1.05 CONTRACTOR USE OF PREMISES:

1. Confine operations at sites to areas permitted by:
 - a. Laws.
 - b. Ordinances.
 - c. Permits.
 - d. Contract Documents.
2. Do not unreasonably encumber site with materials or equipment.
3. Do not load structure with weight that will endanger structure.
4. Assume full responsibility for protection and safekeeping of Contractor's and Owner's material stored on premises and keep the site and building secure at all times.
5. Obtain and pay for use of additional storage or Work areas needed for operations.
6. Limit use of site for Work and storage.
7. Prime Contractors to notify CM of all deliveries 48 hours prior.

PART 2 - PRODUCTS (Not Applicable)

PART 3 - EXECUTION (Not Applicable)

END OF SECTION

ID	Task Name	Duration	Start	Finish	Half 1, 2024							Half 2, 2024							Half 1, 2025							Half 2, 2025						
					N	D	J	F	M	A	M	J	J	A	S	O	N	D	J	F	M	A	M	J	J							
0	CUSD DO EXP ADM 5	433 day	Fri 11/3/23	Fri 7/11/25																												
1	NTP	0 days	Fri 12/1/23	Fri 12/1/23																												
2	Procurement																															
3	Procure Electrical Switchgear	310 days	Fri 11/3/23	Tue 1/21/25																												
4	Procure Mechanical Equipment	200 days	Fri 12/1/23	Fri 9/13/24																												
5	Procure Irrigation booster	160 days	Fri 12/1/23	Thu 7/18/24																												
6																																
7	Mobilize / Site Work																															
8	USA Site / Utility Locate	1 day	Fri 12/1/23	Fri 12/1/23																												
9	Pot Hole (E) Utilities	3 days	Mon 12/4/23	Wed 12/6/23																												
10	Clear & Grub Demo	5 days	Thu 12/7/23	Wed 12/13/23																												
11	Grade / Base Const Yard / Temp Roads	3 days	Thu 12/14/23	Mon 12/18/23																												
12	Set Construction Trailer	1 day	Tue 12/19/23	Tue 12/19/23																												
13	Set Temp Power / Generator	1 day	Tue 12/19/23	Tue 12/19/23																												
14	Temp Water @ Hydrant	1 day	Tue 12/19/23	Tue 12/19/23																												
15	Stake Earthwork / Retention Basins	1 day	Wed 12/20/23	Wed 12/20/23																												
16	Site Grade / Dig Retention Basins	10 days	Thu 12/21/23	Fri 1/5/24																												
17	Stake Building Pads / A & B	1 day	Thu 12/21/23	Thu 12/21/23																												
18	Over Ex / Backfill Building Pads A & B	7 days	Fri 12/22/23	Wed 1/3/24																												
19																																
20	Site Wet Utilities	58 days	Thu 1/4/24	Mon 3/25/24																												
21	Stub Storm and Fire line under FID Line	5 days	Mon 1/8/24	Fri 1/12/24																												
22	Survey FID Irrigation Line	1 day	Mon 1/15/24	Mon 1/15/24																												
23	Install FID Irrigation Line	5 days	Tue 1/16/24	Mon 1/22/24																												
24	Stake Sewer	1 day	Thu 1/4/24	Thu 1/4/24																												
25	Install Site Sewer / POC onsite	15 days	Fri 1/5/24	Thu 1/25/24																												
26	Stake Storm Drain	1 day	Fri 1/26/24	Fri 1/26/24																												
27	Install Site Storm Drain / Manhole / DI	15 days	Mon 1/29/24	Fri 2/16/24																												
28	Stake Fire Main / Hydrant	1 day	Mon 2/19/24	Mon 2/19/24																												
29	Install Fire Main / POC onsite / Fire Hydrant	10 days	Tue 2/20/24	Mon 3/4/24																												
30	Install PIV / CV / FDC	3 days	Tue 2/20/24	Thu 2/22/24																												
31	Stake Domestic Water	1 day	Tue 3/5/24	Tue 3/5/24																												
32	Install Site Domestic / Backflows/POC Onsite	8 days	Wed 3/6/24	Fri 3/15/24																												
33	Stake Gas	1 day	Mon 3/18/24	Mon 3/18/24																												
34	Install Site Gas / POC @ (E) Line	5 days	Tue 3/19/24	Mon 3/25/24																												
35																																
36	Offsite work	124 days	Thu 1/4/24	Wed 6/26/24																												

Project: CUSD DO EXP ADM 5 Date: Wed 10/25/23	Task		Project Summary		Manual Task		Start-only		Deadline	
	Split		Inactive Task		Duration-only		Finish-only		Progress	
	Milestone		Inactive Milestone		Manual Summary Rollup		External Tasks		Manual Progress	
	Summary		Inactive Summary		Manual Summary		External Milestone			

SITE LOGISTIC PLAN LEGEND

- ACCESS ROADS - 20'-0" wide with 2" AC paving over 3" compacted aggregate base at paved runoff areas. Grade to allow drainage.
- ACCESS ROADS - 20'-0" wide with 4" compacted aggregate base section at all roads. Grade to allow drainage.
- CONSTRUCTION TRAILER - 4" compacted aggregate base. 40'X150' Grade to allow drainage.
- PARKING - 4" compacted aggregate base. 150'X150' Grade to allow drainage.
- SEA TRAINS - 4" compacted aggregate base. 40'X150' Grade to allow drainage.
- STORAGE - 4" compacted aggregate base. 150'X150' Grade to allow drainage.
- Temp Water Fill Area - 4" compacted aggregate base. 80'X40' Grade to allow drainage.
- RUMBLE STRIP
- TEMP FENCE

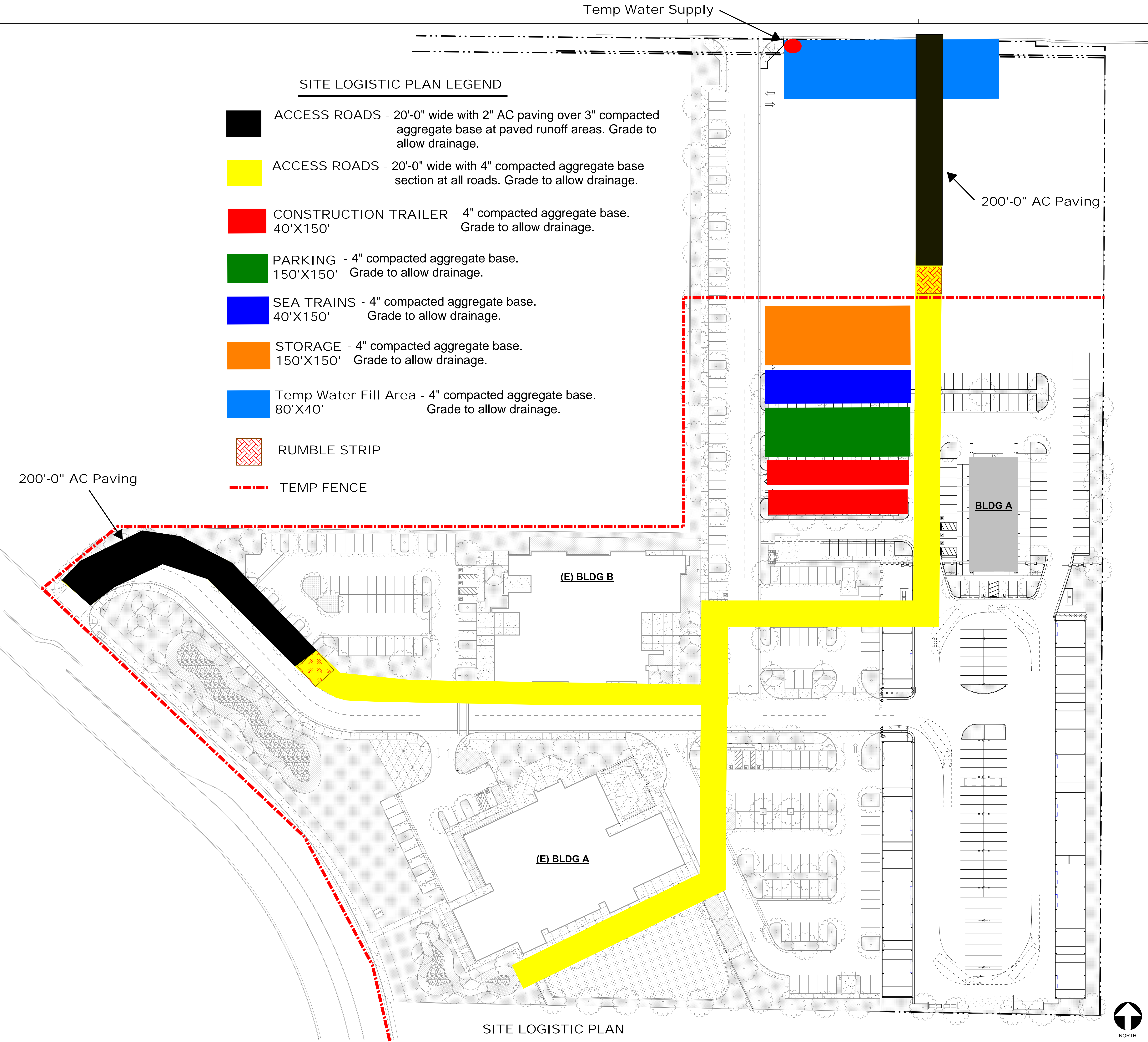

SITE LOGISTIC PLAN

SITE PLAN

1" = 40'-0" 10

CUSD FOWLER AND HERNDON
PHASE 2

PROJECT NO.
23-12560

DRAWING TITLE
SITE PLAN

TETER, INC.
PESNO HEADQUARTERS
VISALIA | BANGORFIELD | MODOESTO | SAN LUIS OBISPO
ARCHITECTS ENGINEERS CONNECTED

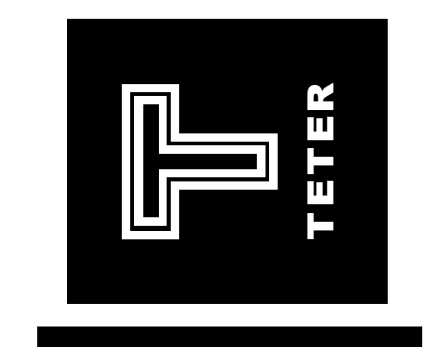

NOT FOR
CONSTRUCTION

MARK	DATE	DESCRIPTION	PROJECT STATUS
MMDDYY			

This file is the property of TETER, INC. and contains its proprietary information. All rights are reserved. No part of this document may be reproduced, stored in a retrieval system, or transmitted in any form or by any means, electronic, mechanical, photocopying, recording, or by any information storage and retrieval system, without the prior written authorization of TETER, INC.

B

AD5-CM01

STORMWATER POLLUTION PREVENTION PLAN

for

CUSD District Office Expansion

RISK LEVEL 1

Legally Responsible Person (LRP):

Clovis Unified School District
1470 Herndon Avenue
Denver Stairs
Assistant Superintendent
(559) 327-9000

Project Address:

S. of Parking Lot on SE. Corner of Fowler Ave. & Herndon Ave.,
Clovis CA, 93611

SWPPP Prepared by:

Paige Noga , PE, QSD
Blair, Church & Flynn Consulting Engineers
451 Clovis Ave. Suite 200
Clovis, CA 93612
(559) 326-1400

SWPPP Preparation Date

March 28, 2023

WDID # **5F10C401070**

Estimated Project Dates:

Start of Construction **07/05/2023**

Completion of Construction

02/09/2025

TABLE OF CONTENTS

Table of Contents	i
Qualified SWPPP Developer.....	1
Legally Responsible Person.....	2
Amendment Log.....	3
Section 1 SWPPP Requirements	4
1.1 Introduction.....	4
1.2 Permit Registration Documents	4
1.3 SWPPP Availability and Implementation.....	5
1.4 SWPPP Amendments.....	5
1.5 Retention of Records.....	6
1.6 Required Non-Compliance Reporting	7
1.7 Annual Report.....	7
1.8 Changes to Permit Coverage.....	7
1.9 Notice of Termination.....	7
Section 2 Project Information	8
2.1 Project and Site Description.....	8
2.1.1 Site Description.....	8
2.1.2 Existing Conditions.....	8
2.1.3 Existing Drainage.....	8
2.1.4 Geology and Groundwater	8
2.1.5 Project Description.....	8
2.1.6 Developed Condition	9
2.2 Permits and Governing Documents	10
2.3 Stormwater Run-On from Offsite Areas.....	10
2.4 Findings of the Construction Site Sediment and Receiving Water Risk Determination 10	
2.5 Construction Schedule	11
2.6 Potential Construction Activity and Pollutant Sources.....	11
2.7 Identification of Non-Stormwater Discharges	11
2.8 Required Site Map Information	12
Section 3 Best Management Practices	14

3.1	Schedule for BMP Implementation	14
3.1.1	Project Specific BMP Descriptions	14
3.2	Erosion and Sediment Control	16
3.2.1	Erosion Control.....	16
3.2.2	Sediment Controls.....	19
3.3	Non-Stormwater Controls and Waste and Materials Management	22
3.3.1	Non-Stormwater Controls.....	22
3.3.2	Materials Management and Waste Management.....	24
3.4	Post construction Stormwater Management Measures	27
Section 4	BMP Inspection, and Maintenance	28
4.1	BMP Inspection and Maintenance	28
4.2	Rain Event Action Plans	28
Section 5	Training	29
Section 6	Responsible Parties and Operators	30
6.1	Responsible Parties	30
6.2	Contractor List	31
Section 7	Construction Site Monitoring Program.....	32
7.1	Purpose.....	32
7.2	Applicability of Permit Requirements	32
7.3.	Weather and Rain Event Tracking.....	32
7.3.1	Weather Tracking.....	32
7.3.2	Rain Gauges	32
7.4	Monitoring Locations.....	33
7.5	Sample Collection Safety, Monitoring, and Monitoring Exemptions	33
7.6	Visual Monitoring.....	34
7.6.1	Routine Observations and Inspections.....	35
7.6.1.1	Routine BMP Inspections	35
7.6.1.2	Non-Stormwater Discharge Observations	36
7.6.2	Rain-Event Triggered Observations and Inspections	36
7.6.2.1	Visual Observations Prior to a Forecasted Qualifying Rain Event.....	36
7.6.2.2	BMP Inspections During an Extended Storm Event.....	36
7.6.2.2	Visual Observations Following a Qualifying Rain Event.....	37
7.6.3	Visual Monitoring Procedures	37

7.6.4	Visual Monitoring Follow-Up and Reporting.....	37
7.6.5	Visual Monitoring Locations	38
7.7	Water Quality Sampling and Analysis.....	38
7.7.1	Sampling and Analysis Plan for Non-Visible Pollutants in Stormwater Runoff Discharges.....	38
7.7.1.2	Sampling Locations – Not Required for Risk Level 1 Projects.....	39
7.7.1.3	Monitoring Preparation.....	39
7.7.1.4	Analytical Constituents.....	40
7.7.1.5	Sample Collection.....	41
7.7.1.6	Sample Analysis.....	42
7.7.1.7	Data Evaluation and Reporting.....	44
7.7.2	Sampling and Analysis Plan for pH and Turbidity in Stormwater Runoff Discharges.....	44
7.7.3	Additional Monitoring Following an NEL Exceedance	44
7.7.4	Sampling and Analysis Plan for Non-Stormwater Discharges	44
7.7.5	Sampling and Analysis Plan for Other Pollutants Required by the Regional Water Board	44
7.7.6	Training of Sampling Personnel	44
7.7.7	Sample Collection and Handling	45
7.7.7.1	Sample Collection.....	45
7.7.7.2	Sample Handling.....	46
7.7.7.3	Sample Documentation Procedures	47
7.11	Quality Assurance and Quality Control.....	47
7.11.1	Field Logs	47
7.11.2	Clean Sampling Techniques	47
7.11.3	Chain of Custody	48
7.11.4	QA/QC Samples.....	48
7.11.4.1	Field Duplicates.....	48
7.11.4.2	Equipment Blanks	48
7.11.4.3	Field Blanks.....	49
7.11.4.4	Travel Blanks	49
7.11.5	Data Verification.....	49
7.12	Records Retention.....	50

CSMP Attachment 1: Weather Reports.....	51
CSMP Attachment 2: Monitoring Records	52
CSMP Attachment 3: Example Forms.....	53
Section 8 References	58
<i>Appendix A: Calculations</i>	
<i>Appendix B: Site Maps</i>	
<i>Appendix C: Permit Registration Documents</i>	
<i>Appendix D: Construction Activities, Materials Used, and Associated Pollutants</i>	
<i>Appendix E: CASQA Stormwater BMP Handbook Portal: Construction Fact Sheets</i>	
<i>Appendix F: BMP Inspection Form</i>	
<i>Appendix G: Training Reporting Form</i>	
<i>Appendix H: Construction General Permit</i>	

QUALIFIED SWPPP DEVELOPER

Approval and Certification of the Stormwater Pollution Prevention Plan

Project Name:

CUSD District Office Expansion

Project Number/ID:

221-0361

“This Stormwater Pollution Prevention Plan and Attachments were prepared under my direction to meet the requirements of the California Construction General Permit (SWRCB Orders No. 2009-009-DWQ as amended by Order 2010-0014-DWQ). I certify that I am a Qualified SWPPP Developer in good standing as of the date signed below.”



QSD Signature

Date

Paige Noga

00839

QSD Name

QSD Certificate Number

Project Engineer, QSD

(559) 326 – 1400

Title and Affiliation

Telephone Number

pnoga@bcf-engr.com

Email

LEGALLY RESPONSIBLE PERSON

Approval and Certification of the Stormwater Pollution Prevention Plan

Project Name: CUSD District Office Expansion

Project Number/ID: 221-0361

“I certify under penalty of law that this document and all Attachments were prepared under my direction or supervision in accordance with a system designed to assure that qualified personnel properly gather and evaluate the information submitted. Based on my inquiry of the person or persons who manage the system or those persons directly responsible for gathering the information, to the best of my knowledge and belief, the information submitted is, true, accurate, and complete. I am aware that there are significant penalties for submitting false information, including the possibility of fine and imprisonment for knowing violations.”

Denver Stairs

Legally Responsible Person

Signature of Legally Responsible Person or Approved Signatory

Date

(559) 327-9000

Name of Legally Responsible Person or Approved Signatory

Telephone Number

AMENDMENT LOG

Project Name:

CUSD District Office Expansion

Project Number/ID

221-0361

Amendment No.	Date	Brief Description of Amendment, include section and page number	Prepared and Approved By
			Name: QSD#
			Name: QSD#
			Name: QSD#
			Name: QSD#
			Name: QSD#
			Name: QSD#
			Name: QSD#
			Name: QSD#
			Name: QSD#
			Name: QSD#

SECTION 1 SWPPP REQUIREMENTS

1.1 INTRODUCTION

The CUSD District Expansion project comprises approximately 9.09 acres and is located at the S. side of the parking lot on S.E. corner of Fowler & Herndon in Clovis, California. The property is owned being developed by Clovis Unified School District. The project location is shown on the Site Map in Appendix B: *Site Maps*.

This Stormwater Pollution Prevention Plan (SWPPP) is designed to comply with California's General Permit for Stormwater Discharges Associated with Construction and Land Disturbance Activities (General Permit) Order No. 2009-0009-DWQ as amended by Order No. 2010-0014-DWQ (NPDES No. CAS000002) issued by the State Water Resources Control Board (State Water Board). This SWPPP has been prepared following the SWPPP Template provided on the California Stormwater Quality Association Stormwater *Best Management Practice Handbook Portal: Construction* (CASQA, 2012). In accordance with the General Permit, Section XIV, this SWPPP is designed to address the following:

- Pollutants and their sources, including sources of sediment associated with construction, construction site erosion and other activities associated with construction activity are controlled;
- Where not otherwise required to be under a Regional Water Quality Control Board (Regional Water Board) permit, all non-stormwater discharges are identified and either eliminated, controlled, or treated;
- Site BMPs are effective and result in the reduction or elimination of pollutants in stormwater discharges and authorized non-stormwater discharges from construction activity to the Best Available Technology/Best Control Technology (BAT/BCT) standard;

Calculations for Risk Level and Runoff Coefficient are included in Appendix A: *Calculations*.

1.2 PERMIT REGISTRATION DOCUMENTS

Required Permit Registration Documents (PRDs) shall be submitted to the State Water Board via the Stormwater Multi Application and Report Tracking System (SMARTS) by the Legally Responsible Person (LRP), or authorized personnel (i.e., Approved Signatory) under the direction of the LRP. The project-specific PRDs include:

1. Notice of Intent (NOI);
2. Risk Assessment (Construction Site Sediment and Receiving Water Risk Determination);
3. Site Map;
4. Annual Fee;
5. Signed Certification Statement (LRP Certification is provided electronically with SMARTS PRD submittal); and
6. SWPPP.

Site Maps can be found in Appendix B: *Site Maps*. A copy of the submitted PRDs shall also be kept in Appendix C: *Permit Registration Documents* along with the Waste Discharge Identification (WDID) confirmation.

Additional PRDs may be required depending on the construction type and location.

- Post-construction water balance calculation;
- Dischargers proposing an alternate soil erodibility factor must submit justification (documentation of methods used [e.g. soil particle size analysis]).

1.3 SWPPP AVAILABILITY AND IMPLEMENTATION

The discharger shall make the SWPPP available at the construction site during working hours (see Section 7.5 of CSMP for working hours) while construction is occurring and shall make it available upon request by a State or Municipal inspector. When the original SWPPP is retained by a crewmember in a construction vehicle and is not currently at the construction site, current copies of the BMPs and map/drawing will be left with the field crew and the original SWPPP shall be made available via a request by radio/telephone. (CGP Section XIV.C)

The SWPPP shall be implemented concurrently with the start of ground disturbing activities.

1.4 SWPPP AMENDMENTS

The SWPPP should be revised when:

- There is a General Permit violation.
- There is a reduction or increase in total disturbed acreage (General Permit Section II Part C).
- BMPs do not meet the objectives of reducing or eliminating pollutants in stormwater discharges.

Additionally, the SWPPP shall be amended when:

- There is a change in construction or operations which may affect the discharge of pollutants to surface waters, groundwater(s), or a municipal separate storm sewer system (MS4);
- When there is a change in the project duration that changes the project's risk level; or
- When deemed necessary by the QSD. The QSD has determined that the changes listed in Table 1.1 can be field determined by the QSP. All other changes shall be made by the QSD as formal amendments to the SWPPP.

The following items shall be included in each amendment:

- Who requested the amendment;
- The location of proposed change;
- The reason for change;
- The original BMP proposed, if any; and
- The new BMP proposed.

Amendments shall be logged at the front of the SWPPP and certification kept in Appendix C: *Permit Registration Documents*. The SWPPP text shall be revised, replaced, and/or hand annotated as necessary to properly convey the amendment. SWPPP amendments must be made by a QSD. The following changes have been designated by the QSD as "to be field determined" and constitute minor changes that the QSP may implement based on field conditions.

Table 1.1 List of Changes to be Field Determined

Candidate changes for field location or determination by QSP⁽¹⁾	Check changes that can be field located or field determined by QSP
Increase quantity of an Erosion or Sediment Control Measure	☑
Relocate/Add stockpiles or stored materials	☑
Relocate or add toilets	☑
Relocate vehicle storage and/or fueling locations	☑
Relocate areas for waste storage	☑
Relocate water storage and/or water transfer location	☑
Changes to access points (entrance/exits)	☑
Change type of Erosion or Sediment Control Measure	☑
Changes to location of erosion or sediment control	☑
Minor changes to schedule or phases	☑
Changes in construction materials	☑
<i>(1) Any field changes not identified for field location or field determination by QSP must be approved by QSD</i>	

1.5 RETENTION OF RECORDS

Paper or electronic records of documents required by this SWPPP shall be retained for a minimum of three years from the date generated or date submitted, whichever is later, for the following items:

- The onsite SWPPP with NOI, COIs, Annual Reports, and NOT
- All inspection reports

These records shall be available at the Site until construction is complete. Records assisting in the determination of compliance with the General Permit shall be made available within a reasonable time, to the Regional Water Board, State Water Board or U.S. Environmental Protection Agency (EPA) upon request. Requests by the Regional Water Board for retention of records for a period longer than three years shall be adhered to.

1.6 REQUIRED NON-COMPLIANCE REPORTING

If a General Permit discharge violation occurs the QSP shall immediately notify the LRP and the LRP shall file a violation report electronically to the Regional Water Board within 30 days of identification of non-compliance using SMARTS. Corrective measures will be implemented immediately following the discharge or written notice of non-compliance from the Regional Water Board. Discharges and corrective actions will be documented on the NAL/NEL Exceedance Site Evaluation Report Form in CSMP Attachment 3 “Example Forms.”

The report to the LRP and to the Regional Water Board will contain the following items:

- The date, time, location, nature of operation and type of unauthorized discharge.
- The cause or nature of the notice or order.
- The control measures (BMPs) deployed before the discharge event, or prior to receiving notice or order.
- The date of deployment and type of control measures (BMPs) deployed after the discharge event, or after receiving the notice or order, including additional measures installed or planned to reduce or prevent re-occurrence.

1.7 ANNUAL REPORT

The General Permit requires that permittees prepare, certify, and electronically submit an Annual Report no later than September 1st of each year. Reporting requirements are identified in Section XVI of the General Permit. Annual reports will be filed in SMARTS and in accordance with information required by the on-line forms.

1.8 CHANGES TO PERMIT COVERAGE

The General Permit allows for the reduction or increase of the total acreage covered under the General Permit when: a portion of the project is complete and/or conditions for termination of coverage have been met; when ownership of a portion of the project is purchased by a different entity; or when new acreage is added to the project.

Modified PRDs shall be filed electronically within 30 days of a reduction or increase in total disturbed area if a change in permit covered acreage is to be sought. The SWPPP shall be modified appropriately, shall be logged at the front of the SWPPP and certification of SWPPP amendments are to be kept in Appendix C: *Permit Registration Documents*.

1.9 NOTICE OF TERMINATION

A Notice of Termination (NOT) must be submitted electronically by the LRP via SMARTS to terminate coverage under the General Permit. The NOT must include a final Site Map and representative photographs of the project site that demonstrate final stabilization has been achieved. The NOT shall be submitted within 90 days of completion of construction. The Regional Water Board will consider a construction site complete when the conditions of the General Permit, Section II.D have been met.

SECTION 2 PROJECT INFORMATION

2.1 PROJECT AND SITE DESCRIPTION

2.1.1 *Site Description*

The CUSD District Expansion Project site comprises approximately 9.09 acres and is located at the south of an existing parking lot on the southeast corner of Fowler Ave. & Herndon Ave. in Clovis, California (36.83616, -119.68276), approximately 0.25 mile south of CA-168 highway. The project site is located approximately 6.5 miles southeast of the San Joaquin River. The project site is located approximately 0.6 miles north of FMFCD Basin 5F, and 1.0 miles northeast of FMFCD Basin 6D. The project is identified on the Vicinity Map in Appendix B: *Site Maps*.

2.1.2 *Existing Conditions*

As of the initial date of this SWPPP, the project site is mostly undeveloped land. The project site is a flat, soil lot with little vegetation, a Fresno Irrigation District irrigation aboveground pipeline structure, and an abandoned asphalt road. There are no known historic sources of contamination at the site according to the Department of Toxic Substances Control (DTSC) *Envirostor* database.

2.1.3 *Existing Drainage*

The project site is relatively level. The elevation of the project site ranges from 375 to 378 feet above mean sea level (msl). Most of the surface drainage at the site currently percolates into the 96% pervious site area. During large storms, stormwater pools in the site and convey as surface flow to the west, towards Fowler Ave. and conveying to an FMFCD curb-gutter storm drain inlet. Stormwater discharges originating from the site are considered direct discharges into FMFCD Basin 5F and FMFCD Basin 6D as defined by the State Water Board. Existing stormwater conveyance systems are shown on the Site Map in Appendix B: *Site Maps*.

The project discharges to FMFCD Basin 5F which is not listed for water quality impairment on the most recent 303(d)-list.

The project discharges to FMFCD Basin 6D which is not listed for water quality impairment on the most recent 303(d)-list.

2.1.4 *Geology and Groundwater*

The site is underlain by loam from approximately 0 to 16 inches below surface level (bsl), sandy clay loam from 16 to 28 inches bsl, clay from 28 to 29 inches bsl, cemented material from 29 to 36 inches bsl, and coarse sandy loam from 36 to 60 inches bsl. Groundwater occurs beneath the site at approximately 260 feet below ground surface. The groundwater gradient is toward the East, according to the California Department of Water Resources *Lines of Equal Elevation of Groundwater* (2011).

2.1.5 *Project Description*

Project land disturbance will occur on approximately 9.04 acres of the project, which comprises 99.47 percent of the total area. Project grading will occur on approximately 8.48 acres of the project, which comprises approximately 93.33 percent of the total area. Grading will include both cut and fill activities, with the total graded material estimated to be 5,087.74 cubic yards.

Approximately 275.73 cubic yards of fill material will be imported during grading activities. Soil will be stockpiled in the future northeast parking lot area as shown on the Site Map in Appendix B: *Site Maps*. Construction activities will not be phased.

2.1.6 Developed Condition

Post construction surface drainage will be directed by new impervious areas to on-site storm drain inlets and roof drains. Stormwater generated from new parking lots will direct stormwater as channelized flow to on-site drain inlets, and new concrete areas will direct stormwater as sheet flow to storm drain inlets. Stormwater collected at the site will be directed to on-site stormwater detention basins, which are designed to overflow during a 10-year storms and convey stormwater west to Fowler Ave. where it will convey to FMFCD Basin 5F.

Post construction drainage patterns and conveyance systems are presented on Figure 2: Site Map in Appendix B: *Site Maps*.

Table 2.1 Construction Site Estimates

Construction site area	9.09	acres
Percent impervious before construction	4	%
Runoff coefficient before construction	0.18	
Percent impervious after construction	64	%
Runoff coefficient after construction	0.63	

Table 2.1 Construction Site Estimates

Project Status	Runoff Coefficient	Site Area (acres)	Average Annual Rainfall (inches)	Average Annual Runoff (acre-feet)
Pre-Construction	0.18	9.09	12	1.64
Post-Construction	0.63	9.09	12	5.73

The project will convert 5.45 acres of developed and undeveloped land to buildings, hardscape, including concrete sidewalk, curb and gutter, and asphalt concrete parking lots. The increase in imperviousness of the site will increase the Average Annual Runoff volume from the site by 4.09 acre-feet. This information is presented in Table 2.1.

2.2 PERMITS AND GOVERNING DOCUMENTS

In addition to the General Permit, the following documents have been taken into account while preparing this SWPPP

- Regional Water Board requirements
- Contract Documents
- Air Quality Regulations and Permits

2.3 STORMWATER RUN-ON FROM OFFSITE AREAS

There is no anticipated offsite run-on to this construction site because the site is flat and surrounded by pervious areas or run-offs areas. The site sits above grade and there are curbs to the South and the West of the site for stormwater to run into.

2.4 FINDINGS OF THE CONSTRUCTION SITE SEDIMENT AND RECEIVING WATER RISK DETERMINATION

A construction site risk assessment has been performed for the project and the resultant risk level is Risk Level 1.

The risk level was determined through the use of the K, LS provided in SMARTS, a site-specific analysis. The risk level is based on project duration, location, proximity to impaired receiving waters and soil conditions. A copy of the Risk Level determination submitted on SMARTS with the PRDs is included in Appendix A: *Calculations*.

Table 2.2 and Table 2.3 summarize the sediment and receiving water risk factors and document the sources of information used to derive the factors.

Table 2.2 Summary of Sediment Risk

RUSLE Factor	Value	Method for establishing value
R	43.25	US Environmental Protection Agency Rainfall Erosivity Factor Calculator
K	0.32	SWRCB Map Risk Categories
LS	0.144	SWRCB Map Risk Categories
Total Predicted Sediment Loss (tons/acre)		1.987
Overall Sediment Risk Low Sediment Risk < 15 tons/ acre Medium Sediment Risk >= 15 and < 75 tons/acre High Sediment Risk >= 75 tons/acre		<input checked="" type="checkbox"/> Low <input type="checkbox"/> Medium <input type="checkbox"/> High

Table 2.3 Summary of Receiving Water Risk

Receiving Water Name	303(d) Listed for Sediment Related Pollutant ⁽¹⁾	TMDL for Sediment Related Pollutant ⁽¹⁾	Beneficial Uses of COLD, SPAWN, and MIGRATORY ⁽¹⁾
FMFCD Basin 5F	<input type="checkbox"/> Yes <input checked="" type="checkbox"/> No	<input type="checkbox"/> Yes <input checked="" type="checkbox"/> No	<input type="checkbox"/> Yes <input checked="" type="checkbox"/> No
FMFCD Basin 6D	<input type="checkbox"/> Yes <input checked="" type="checkbox"/> No	<input type="checkbox"/> Yes <input checked="" type="checkbox"/> No	<input type="checkbox"/> Yes <input checked="" type="checkbox"/> No
Overall Receiving Water Risk			<input checked="" type="checkbox"/> Low <input type="checkbox"/> High
(1) If yes is selected for any option the Receiving Water Risk is High			

Risk Level 1 sites are subject to the narrative effluent limitations specified in the General Permit. The narrative effluent limitations require stormwater discharges associated with construction activity to minimize or prevent pollutants in stormwater and authorized non-stormwater through the use of controls, structures, and best management practices. This SWPPP has been prepared to address Risk Level 1 requirements (General Permit Attachment C).

2.5 CONSTRUCTION SCHEDULE

The site sediment risk was determined based on construction taking place between July 5, 2023 and February 9, 2025. Modification or extension of the schedule (start and end dates) may affect risk determination and permit requirements. The LRP shall contact the QSD if the schedule changes during construction to address potential impact to the SWPPP.

2.6 POTENTIAL CONSTRUCTION ACTIVITY AND POLLUTANT SOURCES

Appendix D: *Construction Activities, Materials Used, and Associated Pollutants* includes a list of construction activities and associated materials that are anticipated to be used onsite. These activities and associated materials will or could potentially contribute pollutants, other than sediment, to stormwater runoff.

The anticipated activities and associated pollutants were used in Section 3 to select the Best Management Practices for the project. Location of anticipated pollutants and associated BMPs are show on the Site Map in Appendix B: *Site Maps*.

For sampling requirements for non-visible pollutants associated with construction activity please refer to Section 7.7.1. For a full and complete list of onsite pollutants, refer to the Material Safety Data Sheets (MSDS), which are retained onsite at the construction trailer.

2.7 IDENTIFICATION OF NON-STORMWATER DISCHARGES

Non-stormwater discharges consist of discharges which do not originate from precipitation events. The General Permit provides allowances for specified non-stormwater discharges that do not cause erosion or carry other pollutants.

Non-stormwater discharges into storm drainage systems or waterways, which are not authorized under the General Permit and listed in the SWPPP, or authorized under a separate NPDES permit, are prohibited.

Non-stormwater discharges that are authorized from this project site include the following:

- Air conditioning condensate
- Irrigation water

These authorized non-stormwater discharges will be managed with the stormwater and non-stormwater BMPs described in Section 3 of this SWPPP and will be minimized by the QSP.

Activities at this site that may result in unauthorized non-stormwater discharges include:

- Oil/fuel drips, leaks, and fueling spills
- Paint, solvent, adhesive, sealant, resin, and grease use and storage
- Asphalt work
- Concrete, plaster, grout, stucco washout
- Concrete curing and concrete curing compound use
- Vehicle/equipment washing
- Pavement/site washing
- Overwatering site for dust control
- Herbicide/pesticide/fertilizer use and storage

Steps will be taken, including the implementation of appropriate BMPs, to ensure that unauthorized discharges are eliminated, controlled, disposed, or treated on-site.

Discharges of construction materials and wastes, such as fuel or paint, resulting from dumping, spills, or direct contact with rainwater or stormwater runoff, are also prohibited.

2.8 REQUIRED SITE MAP INFORMATION

The construction project's Site Map(s) showing the project location, surface water boundaries, geographic features, construction site perimeter and general topography and other requirements identified in Attachment B of the General Permit is located in Appendix B: *Site Maps*. Table 2.6 identifies Map or Sheet Nos. where required elements are illustrated.

Table 2.6 Required Map Information

Included on Map/Plan Sheet No. ⁽¹⁾	Required Element
Figure 1	The project's surrounding area (vicinity)
Figure 2	Site layout
Figure 2	Construction site boundaries
Figure 2	Drainage areas
Figure 2	Discharge locations
Figure 2	Sampling locations, if applicable
Figure 2	Areas of soil disturbance (temporary or permanent)
Figure 2	Active areas of soil disturbance (cut or fill)
Figure 2	Locations of runoff BMPs
Figure 2	Locations of erosion control BMPs
Figure 2	Locations of sediment control BMPs
Figure 2	Locations of sensitive habitats, watercourses, or other features which are not to be disturbed
Figure 2	Waste storage areas
Figure 2	Vehicle storage areas
Figure 2	Material storage areas
Figure 2	Entrance and Exits
Figure 2	Fueling Locations

Notes: (1) Indicate maps or drawings that information is included on (e.g., Vicinity Map, Site Map, Drainage Plans, Grading Plans, Progress Maps, etc.)

SECTION 3 BEST MANAGEMENT PRACTICES

3.1 SCHEDULE FOR BMP IMPLEMENTATION

3.1.1 Project Specific BMP Descriptions

Table 3.1 BMP Implementation Schedule

	BMP	Implementation	Duration
Erosion Control	EC-1, Scheduling	Prior to Construction	Entirety of project
	EC-2, Preservation of Existing Vegetation	Start of Construction	Entirety of project
	EC-3, Hydraulic Mulch	During Construction	As needed during on-going construction activities
	EC-4, Hydroseed	During Construction	As needed during on-going construction activities
	EC-6, Straw Mulch	During Construction	As needed during on-going construction activities
	EC-7, Geotextiles and Mats	During Construction	As needed during on-going construction activities
	EC-8, Wood Mulching	During Construction	As needed for on-going landscaping activities
	EC-15, Soil Preparation-Roughening	Prior to Stabilization	As needed during soil preparation activities
Sediment Control	SE-1, Silt Fence	Prior to Construction	As needed during on-going construction activities
	SE-5, Fiber Rolls	During Construction	As needed during on-going construction activities
	SE-6, Gravel Bag Berm	During Construction	As needed during on-going construction activities
	SE-7, Street Sweeping	During Construction	Weekly, entirety of project
	SE-8, Sandbag Barrier	During Construction	As needed during on-going construction activities
	SE-10, Storm Drain Inlet Protection	Prior to Construction	As needed during on-going construction activities
	SE-14, Biofilter Bags	During Construction	As needed during on-going construction activities
Tracking Control	TC-1, Stabilized Construction Entrance and Exit	Start of Construction	Locations change as needed during on-going construction activities
	TC-2, Stabilized Construction Roadway	Start of Construction	Locations change as needed during on-going construction activities
Wind Erosion	WE-1, Wind Erosion Control	Start of Construction	Entirety of project
Non-Stormwater	NS-1, Water Conservation Practices	During Construction	As needed during on-going construction activities

Table 3.1 BMP Implementation Schedule

	BMP	Implementation	Duration
	NS-2, Dewatering Operation	During Construction	As needed during on-going construction activities
	NS-3, Paving and Grinding Operation	During Construction	As needed during on-going construction activities
	NS-6, Illicit Connection-Illegal Discharge Connection	During Construction	As needed during on-going construction activities
	NS-7, Potable Water Irrigation Discharge Detection	During Construction	As needed during on-going construction activities
	NS-8, Vehicle and Equipment Cleaning	During Construction	As needed during on-going construction activities
	NS-9, Vehicle and Equipment Fueling	During Construction	As needed during on-going construction activities
	NS-10, Vehicle and Equipment Maintenance	During Construction	As needed during on-going construction activities
	NS-12, Concrete Curing	During Construction	As needed during on-going construction activities
	NS-13, Concrete Finishing	During Construction	As needed during on-going construction activities
Waste Management	WM-1, Material Delivery and Storage	During Construction	Entirety of project
	WM-2, Material Use	During Construction	Entirety of project
	WM-3, Stockpile Management	During Construction	Entirety of project
	WM-4, Spill Prevention and Control	During Construction	Entirety of project
	WM-5, Solid Waste Management	During Construction	Entirety of project
	WM-6, Hazardous Waste Management	During Construction	Entirety of project
	WM-7, Contaminated Soil Management	During Construction	Entirety of project
	WM-8, Concrete Waste Management	During Construction	Entirety of project
	WM-9, Sanitary-Septic Waste Management	During Construction	Entirety of project
	WM-10, Liquid Waste Management	During Construction	Entirety of project

3.2 EROSION AND SEDIMENT CONTROL

Erosion and sediment controls are required by the General Permit to provide effective reduction or elimination of sediment related pollutants in stormwater discharges and authorized non-stormwater discharges from the Site. Applicable BMPs are identified in this section for erosion control, sediment control, tracking control, and wind erosion control.

3.2.1 Erosion Control

Erosion control, also referred to as soil stabilization, consists of source control measures that are designed to prevent soil particles from detaching and becoming transported in stormwater runoff. Erosion control BMPs protect the soil surface by covering and/or binding soil particles.

This construction project will implement the following practices to provide effective temporary and final erosion control during construction:

1. Preserve existing vegetation where required and when feasible.
2. The area of soil disturbing operations shall be controlled such that the Contractor is able to implement erosion control BMPs quickly and effectively.
3. Stabilize non-active areas within 14 days of cessation of construction activities or sooner if stipulated by local requirements.
4. Control erosion in concentrated flow paths by applying erosion control blankets, check dams, erosion control seeding or alternate methods.
5. Prior to the completion of construction, apply permanent erosion control to remaining disturbed soil areas.

Sufficient erosion control materials shall be maintained onsite to allow implementation in conformance with this SWPPP.

The following temporary erosion control BMP selection table indicates the BMPs that shall be implemented to control erosion on the construction site. Fact Sheets for temporary erosion control BMPs are provided in Appendix E: *CASQA Stormwater BMP Handbook Portal: Construction Fact Sheets*.

Table 3.2 Temporary Erosion Control BMPs

CASQA Fact Sheet	BMP Name	Meets a Minimum Requirement ⁽¹⁾	BMP Used		If not used, state reason
			YES	NO	
EC-1	Scheduling	✓	✓		
EC-2	Preservation of Existing Vegetation	✓	✓		
EC-3	Hydraulic Mulch	✓ ⁽²⁾	✓		
EC-4	Hydroseed	✓ ⁽²⁾	✓		
EC-5	Soil Binders	✓ ⁽²⁾		✓	Not needed.
EC-6	Straw Mulch	✓ ⁽²⁾	✓		
EC-7	Geotextiles and Mats	✓ ⁽²⁾	✓		
EC-8	Wood Mulching	✓ ⁽²⁾	✓		
EC-9	Earth Dike and Drainage Swales	✓ ⁽³⁾		✓	Not needed.
EC-10	Velocity Dissipation Devices			✓	Not needed.
EC-11	Slope Drains			✓	Not needed.
EC-12	Stream Bank Stabilization			✓	Not needed.
EC-14	Compost Blankets	✓ ⁽²⁾		✓	Not needed.
EC-15	Soil Preparation-Roughening		✓		
EC-16	Non-Vegetated Stabilization	✓ ⁽²⁾		✓	Not needed.
WE-1	Wind Erosion Control	✓	✓		
Alternate BMPs Used:					If used, state reason:
<p>⁽¹⁾ Applicability to a specific project shall be determined by the QSD.</p> <p>⁽²⁾ The QSD shall ensure implementation of one of the minimum measures listed or a combination thereof to achieve and maintain the Risk Level requirements.</p> <p>⁽³⁾ Run-on from offsite shall be directed away from all disturbed areas, diversion of offsite flows may require design/analysis by a licensed civil engineer and/or additional environmental permitting</p>					

These temporary erosion control BMPs shall be implemented in conformance with the following guidelines and as outlined in the BMP Factsheets provided in Appendix E: *CASQA Stormwater BMP Handbook Portal: Construction Fact Sheets*. If there is a conflict between documents, the Site Map will prevail over narrative in the body of the SWPPP or guidance in the BMP Fact Sheets. Site specific details in the Site Map prevail over standard details included in the Site Map. The narrative in the body of the SWPPP prevails over guidance in the BMP Fact Sheets.

3.2.2 *Sediment Controls*

Sediment controls are temporary or permanent structural measures that are intended to complement the selected erosion control measures and reduce sediment discharges from active construction areas. Sediment controls are designed to intercept and settle out soil particles that have been detached and transported by the force of water.

The following sediment control BMP selection table indicates the BMPs that shall be implemented to control sediment on the construction site. Fact Sheets for temporary sediment control BMPs are provided in Appendix E: *CASQA Stormwater BMP Handbook Portal: Construction Fact Sheets*.

Table 3.3 Temporary Sediment Control BMPs

CASQA Fact Sheet	BMP Name	Meets a Minimum Requirement ⁽¹⁾	BMP used		If not used, state reason
			YES	NO	
SE-1	Silt Fence	✓ ^{(2) (3)}	✓		
SE-2	Sediment Basin			✓	Not needed.
SE-3	Sediment Trap			✓	Not needed.
SE-4	Check Dams			✓	Not needed.
SE-5	Fiber Rolls	✓ ⁽²⁾⁽³⁾	✓		
SE-6	Gravel Bag Berm	✓ ⁽³⁾	✓		
SE-7	Street Sweeping	✓	✓		
SE-8	Sandbag Barrier		✓		
SE-9	Straw Bale Barrier			✓	Not needed.
SE-10	Storm Drain Inlet Protection	✓ RL2&3	✓		
SE-11	ATS			✓	Not needed.
SE-12	Manufactured Linear Sediment Controls			✓	Not needed.
SE-13	Compost Sock and Berm	✓ ⁽³⁾		✓	Not needed.
SE-14	Biofilter Bags	✓ ⁽³⁾	✓		
TC-1	Stabilized Construction Entrance and Exit	✓	✓		
TC-2	Stabilized Construction Roadway		✓		
TC-3	Entrance Outlet Tire Wash			✓	
Alternate BMPs Used:					If used, state reason:
<p>⁽¹⁾ Applicability to a specific project shall be determined by the QSD</p> <p>⁽²⁾ The QSD shall ensure implementation of one of the minimum measures listed or a combination thereof to achieve and maintain the Risk Level requirements</p> <p>⁽³⁾ Risk Level 2 & 3 shall provide linear sediment control along toe of slope, face of slope, and at the grade breaks of exposed slope</p>					

These temporary sediment control BMPs shall be implemented in conformance with the following guidelines and in accordance with the BMP Fact Sheets provided in Appendix E:

CASQA Stormwater BMP Handbook Portal: Construction Fact Sheets. If there is a conflict between documents, the Site Map will prevail over narrative in the body of the SWPPP or guidance in the BMP Fact Sheets. Site specific details in the Site Map prevail over standard details included in the Site Map. The narrative in the body of the SWPPP prevails over guidance in the BMP Fact Sheets.

3.3 NON-STORMWATER CONTROLS AND WASTE AND MATERIALS MANAGEMENT

3.3.1 *Non-Stormwater Controls*

Non-stormwater discharges into storm drainage systems or waterways, which are not authorized under the General Permit, are prohibited. Non-stormwater discharges for which a separate NPDES permit is required by the local Regional Water Board are prohibited unless coverage under the separate NPDES permit has been obtained for the discharge. The selection of non-stormwater BMPs is based on the list of construction activities with a potential for non-stormwater discharges identified in Section 2.7 of this SWPPP.

The following non-stormwater control BMP selection table indicates the BMPs that shall be implemented to control sediment on the construction site. Fact Sheets for temporary non-stormwater control BMPs are provided in Appendix E: *CASQA Stormwater BMP Handbook Portal: Construction Fact Sheets*.

Non-stormwater BMPs shall be implemented in conformance with the following guidelines and in accordance with the BMP Fact Sheets provided in Appendix E: *CASQA Stormwater BMP Handbook Portal: Construction Fact Sheets*. If there is a conflict between documents, the Site Map will prevail over narrative in the body of the SWPPP or guidance in the BMP Fact Sheets. Site specific details in the Site Map prevail over standard details included in the Site Map. The narrative in the body of the SWPPP prevails over guidance in the BMP Fact Sheets.

Table 3.4 Temporary Non-Stormwater BMPs

CASQA Fact Sheet	BMP Name	Meets a Minimum Requirement ⁽¹⁾	BMP used		If not used, state reason
			YES	NO	
NS-1	Water Conservation Practices	✓	✓		
NS-2	Dewatering Operation		✓		
NS-3	Paving and Grinding Operation		✓		
NS-4	Temporary Stream Crossing			✓	Not needed.
NS-5	Clear Water Diversion			✓	Not needed.
NS-6	Illicit Connection- Illegal Discharge Connection	✓	✓		
NS-7	Potable Water Irrigation Discharge Detection		✓		
NS-8	Vehicle and Equipment Cleaning	✓	✓		
NS-9	Vehicle and Equipment Fueling	✓	✓		
NS-10	Vehicle and Equipment Maintenance	✓	✓		
NS-11	Pile Driving Operation			✓	Not needed.
NS-12	Concrete Curing		✓		
NS-13	Concrete Finishing		✓		
NS-14	Material and Equipment Use Over Water			✓	Not needed.
NS-15	Demolition Removal Adjacent to Water			✓	Not needed.
NS-16	Temporary Batch Plants			✓	Not needed.
Alternate BMPs Used:			If used, state reason:		
⁽¹⁾ Applicability to a specific project shall be determined by the QSD					

3.3.2 *Materials Management and Waste Management*

Materials management control practices consist of implementing procedural and structural BMPs for handling, storing and using construction materials to prevent the release of those materials into stormwater discharges. The amount and type of construction materials to be utilized at the Site will depend upon the type of construction and the length of the construction period. The materials may be used continuously, such as fuel for vehicles and equipment, or the materials may be used for a discrete period, such as soil binders for temporary stabilization.

Waste management consist of implementing procedural and structural BMPs for handling, storing and ensuring proper disposal of wastes to prevent the release of those wastes into stormwater discharges.

Materials and waste management pollution control BMPs shall be implemented to minimize stormwater contact with construction materials, wastes and service areas; and to prevent materials and wastes from being discharged off-site. The primary mechanisms for stormwater contact that shall be addressed include:

- Direct contact with precipitation
- Contact with stormwater run-on and runoff
- Wind dispersion of loose materials
- Direct discharge to the storm drain system through spills or dumping
- Extended contact with some materials and wastes, such as asphalt cold mix and treated wood products, which can leach pollutants into stormwater.

A list of construction activities is provided in Section 2.6. The following Materials and Waste Management BMP selection table indicates the BMPs that shall be implemented to handle materials and control construction site wastes associated with these construction activities. Fact Sheets for Materials and Waste Management BMPs are provided in Appendix E: *CASQA Stormwater BMP Handbook Portal: Construction Fact Sheets*.

Table 3.5 Temporary Materials Management BMPs

CASQA Fact Sheet	BMP Name	Meets a Minimum Requirement ⁽¹⁾	BMP used		If not used, state reason
			YES	NO	
WM-01	Material Delivery and Storage	✓	✓		
WM-02	Material Use	✓	✓		
WM-03	Stockpile Management	✓	✓		
WM-04	Spill Preservation and Control	✓	✓		
WM-05	Solid Waste Management	✓	✓		
WM-06	Hazardous Waste Management	✓	✓		
WM-07	Contaminated Soil Management		✓		
WM-08	Concrete Waste Management	✓	✓		
WM-09	Sanitary-Septic Waste Management	✓	✓		
WM-10	Liquid Waste Management		✓		
Alternate BMPs Used:				If used, state reason:	
⁽¹⁾ Applicability to a specific project shall be determined by the QSD.					

Material management BMPs shall be implemented in conformance with the following guidelines and in accordance with the BMP Fact Sheets provided in Appendix E: *CASQA Stormwater BMP Handbook Portal: Construction Fact Sheets*. If there is a conflict between documents, the Site Map will prevail over narrative in the body of the SWPPP or guidance in the BMP Fact Sheets. Site specific details in the Site Map prevail over standard details included in the Site Map. The narrative in the body of the SWPPP prevails over guidance in the BMP Fact Sheets.

3.4 POST CONSTRUCTION STORMWATER MANAGEMENT MEASURES

Post construction BMPs are permanent measures installed during construction, designed to reduce or eliminate pollutant discharges from the site after construction is completed.

This site is located in an area subject to a Phase I or Phase II Municipal Separate Storm Sewer System (MS4) permit approved Stormwater Management Plan. Yes No

Post construction runoff reduction requirements have been satisfied through the MS4 program, this project is exempt from provision XIII A of the General Permit. A section of the Fresno Metropolitan Flood Control District's Stormwater Management Plan will be uploaded in SMARTS to document compliance with the MS4 post-construction requirements.

SECTION 4 BMP INSPECTION, AND MAINTENANCE

4.1 BMP INSPECTION AND MAINTENANCE

The General Permit requires routine weekly inspections of BMPs, along with inspections before, during, and after qualifying rain events. A BMP inspection checklist must be filled out for inspections and maintained on-site with the SWPPP. The inspection checklist includes the necessary information covered in Section 7.6. A blank inspection checklist can be found in Appendix F: *BMP Inspection Form*. Completed checklists shall be kept in CSMP Attachment 2 “Monitoring Records.

BMPs shall be maintained regularly to ensure proper and effective functionality. If necessary, corrective actions shall be implemented within 72 hours of identified deficiencies and associated amendments to the SWPPP shall be prepared by the QSD.

Specific details for maintenance, inspection, and repair of Construction Site BMPs can be found in the BMP Factsheets in Appendix E: *CASQA Stormwater BMP Handbook Portal: Construction Fact Sheets*.

4.2 RAIN EVENT ACTION PLANS

Rain Event Action Plans (REAPs) are not required for Risk Level 1 projects.

SECTION 5 TRAINING

Appendix G: *Training Reporting Form* identifies the QSPs for the project and those who have been trained by the QSP. To promote stormwater management awareness specific for this project, periodic training of job-site personnel shall be included as part of routine project meetings (e.g. daily/weekly tailgate safety meetings), or task specific trainings as needed.

The QSP shall be responsible for providing this information at the meetings, and subsequently completing the training logs shown in Appendix G: *Training Reporting Form*, which identifies the site-specific stormwater topics covered as well as the names of site personnel who attended the meeting. Tasks may be delegated to trained employees by the QSP provided adequate supervision and oversight is provided. Training shall correspond to the specific task delegated including: SWPPP implementation; BMP inspection and maintenance; and record keeping.

Documentation of training activities (formal and informal) is retained in SWPPP Appendix G: *Training Reporting Form*.

SECTION 6 RESPONSIBLE PARTIES AND OPERATORS

6.1 RESPONSIBLE PARTIES

Approved Signatories who are responsible for SWPPP implementation and have authority to sign permit-related documents are listed below. The Approved Signatories for the project are listed and certified by the LRP in SMARTS. The Approved Signatories assigned to this project are:

Name	Title	Phone Number

QSPs identified for the project are identified in Appendix G: *Training Reporting Form*. The QSP shall have primary responsibility and significant authority for the implementation, maintenance and inspection/monitoring of SWPPP requirements. The QSP will be available at all times throughout the duration of the project. Duties of the QSP include but are not limited to:

- Implementing all elements of the General Permit and SWPPP, including but not limited to:
 - Ensuring all BMPs are implemented, inspected, and properly maintained;
 - Performing non-stormwater and stormwater visual observations and inspections;
 - Performing non-stormwater and storm sampling and analysis, as required;
 - Performing routine inspections and observations;
 - Implementing non-stormwater management, and materials and waste management activities such as: monitoring discharges; general Site clean-up; vehicle and equipment cleaning, fueling and maintenance; spill control; ensuring that no materials other than stormwater are discharged in quantities which will have an adverse effect on receiving waters or storm drain systems; etc.;
- The QSP may delegate these inspections and activities to an appropriately trained employee but shall ensure adequacy and adequate deployment.
- Ensuring elimination of unauthorized discharges.
- The QSPs shall be assigned authority by the LRP to mobilize crews in order to make immediate repairs to the control measures.

- Coordinate with the Contractor(s) to assure all of the necessary corrections/repairs are made immediately and that the project complies with the SWPPP, the General Permit and approved plans at all times.
- Notifying the LRP or Authorized Signatory immediately of off-site discharges or other non-compliance events.

6.2 CONTRACTOR LIST

Contractor

Name: _____

Title: _____

Company: _____

Address: _____

Phone Number: _____

Number (24/7): _____

SECTION 7 CONSTRUCTION SITE MONITORING PROGRAM

7.1 *Purpose*

This Construction Site Monitoring Program was developed to address the following objectives:

1. To determine whether non-visible pollutants are present at the construction site and are causing or contributing to exceedances of water quality objectives;
2. To determine whether immediate corrective actions, additional Best Management Practices (BMP) implementation, or SWPPP revisions are necessary to reduce pollutants in stormwater discharges and authorized non-stormwater discharges;
3. To determine whether BMPs included in the SWPPP are effective in preventing or reducing pollutants in stormwater discharges and authorized non-stormwater discharges.

7.2 *Applicability of Permit Requirements*

This project has been determined to be a Risk Level 1 project. The General Permit identifies the following types of monitoring as being applicable for a Risk Level 1 project.

Risk Level 1

- Visual inspections of Best Management Practices (BMPs);
- Visual monitoring of the site related to qualifying storm events;
- Visual monitoring of the site for non-stormwater discharges;
- Sampling and analysis of construction site runoff for non-visible pollutants when applicable; and
- Sampling and analysis of construction site runoff as required by the Regional Water Board when applicable.

7.3. *Weather and Rain Event Tracking*

Visual monitoring and inspections requirements of the General Permit are triggered by a qualifying rain event. The General Permit defines a qualifying rain event as any event that produces ½ inch of precipitation. A minimum of 48 hours of dry weather will be used to distinguish between separate qualifying storm events.

7.3.1 **Weather Tracking**

The QSP should daily consult the National Oceanographic and Atmospheric Administration (NOAA) for the weather forecasts. These forecasts can be obtained at <http://www.srh.noaa.gov/>. Weather reports should be printed and maintained with the SWPPP in CSMP Attachment 1 “Weather Reports”.

7.3.2 **Rain Gauges**

The QSP shall install a rain gauge(s) on the project site. Locate the gauge in an open area away from obstructions such as trees or overhangs. Mount the gauge on a post at a height of 3 to 5 feet with the gauge extending several inches beyond the post. Make sure that the top of the gauge is level. Make sure the post is not in an area where rainwater can indirectly splash from sheds, equipment, trailers, etc.

The rain gauge(s) shall be read daily during normal site scheduled hours. The rain gauge should be read at approximately the same time every day and the date and time of each reading recorded. Log rain gauge readings in CSMP Attachment 1 “Weather Records”. Follow the rain gauge instructions to obtain accurate measurements.

Once the rain gauge reading has been recorded, accumulated rain shall be emptied and the gauge reset.

For comparison with the site rain gauge, the nearest appropriate governmental rain gauge(s) is located at Fresno Yosemite International Airport, and can be accessed at the NOAA website.

7.4 Monitoring Locations

Monitoring locations are shown on the Site Maps in Appendix B: *Site Maps*. Monitoring locations are described in the Sections 7.6 and 7.7.

Whenever changes in the construction site might affect the appropriateness of sampling locations, the sampling locations shall be revised accordingly. All such revisions shall be implemented as soon as feasible and the SWPPP amended. Temporary changes that result in a one-time additional sampling location do not require a SWPPP amendment.

7.5 Sample Collection Safety, Monitoring, and Monitoring Exemptions

To maintain sample integrity and prevent cross-contamination, sampling collection personnel will:

- Wear a clean pair of surgical gloves prior to the collection and handling of each sample at each location.
- Not contaminate the inside of the sample bottle by not allowing it to come into contact with any material other than the water sample.
- Discard sample bottles or sample lids that have been dropped onto the ground prior to sample collection.
- Not leave the cooler lid open for an extended period of time once samples are placed inside.
- Not sample near a running vehicle where exhaust fumes may impact the sample.
- Not touch the exposed end of a sampling tube, if applicable.
- Avoid allowing rainwater to drip from rain gear or other surfaces into sample bottles
- Not eat, smoke, or drink during sample collection.
- Not sneeze or cough in the direction of an open sample bottle.
- Minimize the exposure of the samples to direct sunlight, as sunlight may cause biochemical transformation of the sample to take place.
- Decontaminate sampling equipment prior to sample collection using a TSP-soapy water wash, distilled water rinse, and final rinse with distilled water.
- Dispose of decontamination water/soaps appropriately; i.e., not discharge to the storm drain system or receiving water.

This project is not required to collect samples or conduct visual observations (inspections) under the following conditions:

- During dangerous weather conditions such as flooding and electrical storms.
- Outside of scheduled site business hours.

Scheduled site business hours are: Site Business Hours (M-F 7-5).

If monitoring (visual monitoring or sample collection) of the site is unsafe because of the dangerous conditions noted above, then the QSP shall document the conditions for why an exception to performing the monitoring was necessary. The exemption documentation shall be filed in CSMP Attachment 2 “Monitoring Records”.

7.6 Visual Monitoring

Visual monitoring includes observations and inspections. Inspections of BMPs are required to identify and record BMPs that need maintenance to operate effectively, that have failed, or that could fail to operate as intended. Visual observations of the site are required to observe storm water drainage areas to identify any spills, leaks, or uncontrolled pollutant sources.

Table 7.1 identifies the required frequency of visual observations and inspections. Inspections and observations will be conducted at the locations identified in Section 7.6.3.

Table 7.1 Frequency of Visual Observations and Inspections

Type of Inspection	Frequency
<i>Routine Inspections</i>	
BMP Inspections	
EC-01 Scheduling	Daily/Weekly
EC-02 Preservation of Vegetation	Daily/Weekly
EC-03 Hydro-Mulch	Daily/Weekly
EC-04 Hydro-Seed	Daily/Weekly
EC-06 Straw Mulch	Daily/Weekly
EC-07 Geotextiles, Plastic Covers, & Erosion Control	Daily/Weekly
EC-08 Wood Mulching	Daily/Weekly
EC-15 Soil Preparation/Roughening	Daily/Weekly
SE-01 Silt Fence	Daily/Weekly
SE-05 Fiber Rolls	Daily/Weekly
SE-06 Gravel Bag Berm	Daily/Weekly
SE-07 Street Sweeping and Vacuuming	Daily/Weekly
SE-08 Sandbag Barrier	Daily/Weekly
SE-10 Inlet Protection	Daily/Weekly
SE-14 Biofilter Bags	Daily/Weekly

WE-01 Wind Erosion Control	Daily/Weekly
TC-01 Stabilized entrance/exit	Daily/Weekly
TC-02 Stabilized Construction Roadway	Daily/Weekly
NS-01 Water Conservation Practices	Daily/Weekly
NS-02 Dewatering Operations	Daily/Weekly
NS-03 Paving & Grinding Operations	Daily/Weekly
NS-06 Illicit Connection/Discharge	Daily/Weekly
NS-07 Potable Water/Irrigation	Daily/Weekly
NS-08 Vehicle & Equipment Cleaning	Daily/Weekly
NS-09 Vehicle and Equipment Fueling	Daily/Weekly
NS-10 Vehicle & Equipment Maintenance	Daily/Weekly
NS-12 Concrete Curing	Daily/Weekly
NS-13 Concrete Finishing	Daily/Weekly
WM-01 Material Delivery and Storage	Daily/Weekly
WM-02 Material Use	Daily/Weekly
WM-03 Stockpile Management	Daily/Weekly
WM-04 Spill Prevention and Control	Daily/Weekly
WM-05 Solid Waste Management	Daily/Weekly
WM-06 Hazardous Waste Management	Daily/Weekly
WM-07 Contaminated Soil Management	Daily/Weekly
WM-08 Concrete Waste Management	Daily/Weekly
WM-09 Sanitary/Septic Waste Management	Daily/Weekly
WM-10 Liquid Waste Management	Daily/Weekly
Non-Stormwater Discharge Observations	Quarterly during daylight hours
<i>Rain Event Triggered Inspections</i>	
Site Inspections Prior to a QRE	Within 48 hours of a QRE ¹
BMP Inspections During an Extended Storm Event	Every 24-hour period of a extended storm event ¹
Site Inspections Following a QRE	Within 48 hours of a QRE ¹

7.6.1 Routine Observations and Inspections

Routine site inspections and visual monitoring are necessary to ensure that the project is in compliance with the requirements of the Construction General Permit.

7.6.1.1 Routine BMP Inspections

Inspections of BMPs are conducted to identify and record:

- BMPs that are properly installed;
- BMPs that need maintenance to operate effectively;
- BMPs that have failed; or
- BMPs that could fail to operate as intended.

7.6.1.2 *Non-Stormwater Discharge Observations*

Each drainage area will be inspected for the presence of or indications of prior unauthorized and authorized non-stormwater discharges. Inspections will record:

- Presence or evidence of any non-stormwater discharge (authorized or unauthorized);
- Pollutant characteristics (floating and suspended material, sheen, discoloration, turbidity, odor, etc.); and
- Source of discharge.

7.6.2 **Rain-Event Triggered Observations and Inspections**

Visual observations of the site and inspections of BMPs are required prior to a qualifying rain event; following a qualifying rain event, and every 24-hour period during a qualifying rain event. Pre-rain inspections will be conducted after consulting NOAA and determining that a precipitation event with a 50% or greater probability of precipitation has been predicted.

7.6.2.1 *Visual Observations Prior to a Forecasted Qualifying Rain Event*

Within 48-hours prior to a qualifying event a stormwater visual monitoring site inspection will include observations of the following locations:

- Stormwater drainage areas to identify any spills, leaks, or uncontrolled pollutant sources;
- BMPs to identify if they have been properly implemented;
- Any stormwater storage and containment areas to detect leaks and ensure maintenance of adequate freeboard.

Consistent with guidance from the State Water Resources Control Board, pre-rain BMP inspections and visual monitoring will be triggered by a NOAA forecast that indicates a probability of precipitation of 50% or more in the project area.

7.6.2.2 *BMP Inspections During an Extended Storm Event*

During an extended rain event BMP inspections will be conducted to identify and record:

- BMPs that are properly installed;
- BMPs that need maintenance to operate effectively;
- BMPs that have failed; or
- BMPs that could fail to operate as intended.

If the construction site is not accessible during the rain event, the visual inspections shall be performed at all relevant outfalls, discharge points, downstream locations. The inspections should record any projected maintenance activities.

7.6.2.2 *Visual Observations Following a Qualifying Rain Event*

Within 48 hours following a qualifying rain event (0.5 inches of rain) a stormwater visual monitoring site inspection is required to observe:

- Stormwater drainage areas to identify any spills, leaks, or uncontrolled pollutant sources;
- BMPs to identify if they have been properly designed, implemented, and effective;
- Need for additional BMPs;
- Any stormwater storage and containment areas to detect leaks and ensure maintenance of adequate freeboard; and
- Discharge of stored or contained rain water.

7.6.3 **Visual Monitoring Procedures**

Visual monitoring shall be conducted by the QSP or staff trained by and under the supervision of the QSP.

The name(s) and contact number(s) of the site visual monitoring personnel are listed below and their training qualifications are provided in Appendix G: *Training Reporting Form*.

Assigned inspector: _____ Contact phone: _____

Alternate inspector: _____ Contact phone: _____

Stormwater observations shall be documented on the *Visual Inspection Field Log Sheet* (see CSMP Attachment 3 “Example Forms”). BMP inspections shall be documented on the site-specific BMP inspection checklist. Any photographs used to document observations will be referenced on stormwater site inspection report and maintained with the Monitoring Records in Attachment 2.

The completed reports will be kept in CSMP Attachment 2 “Monitoring Records”.

7.6.4 **Visual Monitoring Follow-Up and Reporting**

Correction of deficiencies identified by the observations or inspections, including required repairs or maintenance of BMPs, shall be initiated and completed as soon as possible.

If identified deficiencies require design changes, including additional BMPs, the implementation of changes will be initiated within 72 hours of identification and be completed as soon as possible. When design changes to BMPs are required, the SWPPP shall be amended to reflect the changes.

Deficiencies identified in site inspection reports and correction of deficiencies will be tracked on the *Inspection Field Log Sheet* or *BMP Inspection Report* and shall be submitted to the QSP and shall be kept in CSMP Attachment 2 “Monitoring Records”.

Results of visual monitoring must be summarized and reported in the Annual Report.

7.6.5 Visual Monitoring Locations

The inspections and observations identified in Sections 7.6.1 and 7.6.2 will be conducted at the locations identified in this section.

7.7 Water Quality Sampling and Analysis

7.7.1 Sampling and Analysis Plan for Non-Visible Pollutants in Stormwater Runoff Discharges

This Sampling and Analysis Plan for Non-Visible Pollutants describes the sampling and analysis strategy and schedule for monitoring non-visible pollutants in stormwater runoff discharges from the project site.

Sampling for non-visible pollutants will be conducted when (1) a breach, leakage, malfunction, or spill is observed; and (2) the leak or spill has not been cleaned up prior to the rain event; and (3) there is the potential for discharge of non-visible pollutants to surface waters or drainage system.

The following construction materials, wastes, or activities, as identified in Section 2.6, are potential sources of non-visible pollutants to stormwater discharges from the project. Storage, use, and operational locations are shown on the Site Maps in Appendix B: *Site Maps*.

- Adhesives
- Solvents
- Sealants
- Herbicides
- Pesticides
- Concrete curing compound

The following existing site features, as identified in Section 2.6, are potential sources of non-visible pollutants to stormwater discharges from the project. Locations of existing site features contaminated with non-visible pollutants are shown on the Site Maps in Appendix B: *Site Maps*.

- None

The following soil amendments have the potential to change the chemical properties, engineering properties, or erosion resistance of the soil and will be used on the project site. Locations of soil amendment application are shown on the Site Maps in Appendix B: *Site Maps*.

- None

7.7.1.1 Sampling Schedule

Samples for the potential non-visible pollutant(s) and a sufficiently large unaffected background sample shall be collected during the first two hours of discharge from rain events that result in a sufficient discharge for sample collection. Samples shall be collected during the site's scheduled hours and shall be collected regardless of the time of year and phase of the construction.

Collection of discharge samples for non-visible pollutant monitoring will be triggered when any of the following conditions are observed during site inspections conducted prior to or during a rain event.

- Materials or wastes containing potential non-visible pollutants are not stored under watertight conditions. Watertight conditions are defined as (1) storage in a watertight container, (2) storage under a watertight roof or within a building, or (3) protected by temporary cover and containment that prevents stormwater contact and runoff from the storage area.
- Materials or wastes containing potential non-visible pollutants are stored under watertight conditions, but (1) a breach, malfunction, leakage, or spill is observed, (2) the leak or spill is not cleaned up prior to the rain event, and (3) there is the potential for discharge of non-visible pollutants to surface waters or a storm drain system.
- A construction activity, including but not limited to those in Section 2.6, with the potential to contribute non-visible pollutants (1) was occurring during or within 24 hours prior to the rain event, (2) BMPs were observed to be breached, malfunctioning, or improperly implemented, and (3) there is the potential for discharge of non-visible pollutants to surface waters or a storm drain system.
- Soil amendments that have the potential to change the chemical properties, engineering properties, or erosion resistance of the soil have been applied, and there is the potential for discharge of non-visible pollutants to surface waters or a storm drain system.
- Stormwater runoff from an area contaminated by historical usage of the site has been observed to combine with stormwater runoff from the site, and there is the potential for discharge of non-visible pollutants to surface waters or a storm drain system.

7.7.1.2 *Sampling Locations – Not Required for Risk Level 1 Projects*

Sampling locations are based on proximity to planned non-visible pollutant storage, occurrence or use; accessibility for sampling, and personnel safety. Planned non-visible pollutant sampling locations are shown on the Site Maps in Appendix B: *Site Maps* and include the locations identified in Table 7.5 through 7.10.

If a stormwater visual monitoring site inspection conducted prior to or during a storm event identifies the presence of a material storage, waste storage, or operations area with spills or the potential for the discharge of non-visible pollutants to surface waters or a storm drain system that is at a location not listed above and has not been identified on the Site Maps, sampling locations will be selected by the QSP using the same rationale as that used to identify planned locations. Non-visible pollutant sampling locations shall be identified by the QSP on the pre-rain event inspection form prior to a forecasted qualifying rain event.

7.7.1.3 *Monitoring Preparation*

Non-visible pollutant samples will be collected by:

- | | | |
|------------|---|--|
| Contractor | <input type="checkbox"/> Yes | <input checked="" type="checkbox"/> No |
| Consultant | <input type="checkbox"/> Yes | <input checked="" type="checkbox"/> No |
| Laboratory | <input checked="" type="checkbox"/> Yes | <input type="checkbox"/> No |

Samples on the project site will be collected by the following:

Company Name: BSK Associates – Fresno
 Street Address: 1414 Stanislaus St,
 City, State Zip: Fresno, CA 93706
 Telephone Number: (559) 497-2888
 Point of Contact: Lisa Cardenas
 Name of Sampler(s): TBD
 Name of Alternate(s): TBD

The QSP or his/her designee will contact the sampling laboratory 24 hours prior to a predicted rain event or for an unpredicted event, as soon as a rain event begins if one of the triggering conditions is identified during an inspection to ensure that adequate sample collection personnel and supplies for monitoring non-visible pollutants are available and will be mobilized to collect samples on the project site in accordance with the sampling schedule.

7.7.1.4 Analytical Constituents

Table 7.11 lists the specific sources and types of potential non-visible pollutants on the project site and the water quality indicator constituent(s) for that pollutant.

Potential Pollutant Source/ Applicable Construction Activity	Water Quality Indicator Constituent
Adhesives	COD, Phenols, SVOCs
Asphalt Work	VOCs
Concrete/Masonry Work	
Sealant (Methyl Methacrylate)	SVOC
Curing Compounds	VOCs, SVOCs, pH
Ash, Slag, Sand	pH, Al, Ca, Va, Zn
Grading/Earthworks	
Gypsum/Lime amendments	pH
Contaminated Soil	Constituents specific to known contaminants, check with Laboratory
Landscaping	
Pesticides/Herbicides	Product dependent, see label and check with Laboratory
Fertilizers	TKN, NO ₃ , BOD, COD, DOC, Sulfate, NH ₃ , Phosphate, Potassium

Potential Pollutant Source/ Applicable Construction Activity	Water Quality Indicator Constituent
Aluminum Sulfate	Al, TDS, Sulfate
Liquid Waste	Constituents specific to materials, check with Laboratory
Painting	
Resins	COD, SVOCs
Thinners	COD, VOCs
Paint strippers	VOCs, SVOCs, metals
Lacquers, varnishes, enamels	COD, VOCs, SVOCs
Sealants	COD
Adhesives	Phenols, SVOCs
Planting/Vegetation Management	
Vegetation Stockpiles	BOD
Sanitary Waste Sewer line breaks and portable toilets	BOD, Total/Fecal coliform
Soil Preparation/Amendments/Dust Control	
Polymer/Co-polymers	TKN, NO ₃ , BOD, COD, DOC, Sulfate, Ni
Lignin Sulfate	TDS, alkalinity
Psyllium	COD, TOC
Guar/Plant Fums	COD, TOC, Ni
Solid Waste (leakage)	BOD
Vehicle and Equipment Use	
Batteries	Sulfuric acid; Pb, pH

7.7.1.5 *Sample Collection*

Samples of discharge shall be collected at the designated non-visible pollutant sampling locations shown on the Site Maps in Appendix B: *Site Maps* or in the locations determined by observed breaches, malfunctions, leakages, spills, operational areas, soil amendment application areas, and historical site usage areas that triggered the sampling event.

Grab samples shall be collected and preserved in accordance with the methods identified in the Table, “Sample Collection, Preservation and Analysis for Monitoring Non-Visible Pollutants” provided in Section 7.7.1.6. Only the QSP, or personnel trained in water quality sampling under the direction of the QSP shall collect samples.

Sample collection and handling requirements are described in Section 7.7.7.

7.7.1.6 *Sample Analysis*

Samples shall be analyzed using the analytical methods identified in the Table 7.12.

Samples will be analyzed by:

Laboratory Name: BSK Associates – Fresno
Street Address: 1414 Stanislaus St,
City, State Zip: Fresno, CA 93706
Telephone Number: (559) 497-2888
Point of Contact: Lisa Cardenas
ELAP Certification Number: 04227CA

Samples will be delivered to the laboratory by:

Driven by Contractor	<input type="checkbox"/> Yes	<input checked="" type="checkbox"/> No
Picked up by Laboratory Courier	<input checked="" type="checkbox"/> Yes	<input type="checkbox"/> No
Shipped	<input type="checkbox"/> Yes	<input checked="" type="checkbox"/> No

Table 7.12 Sample Collection, Preservation and Analysis for Monitoring Non-Visible Pollutants

Constituent	Analytical Method	Minimum Sample Volume	Sample Containers	Sample Preservation	Reporting Limit	Maximum Holding Time
Lead Sulfate, Battery Acid	EPA 150.1 ph / EPA 300 Sulfate	500 ml	500 ml+ Plastic Container	Ice / refrigeration	10 ph / 10 Sulfate	14 days
Lead from Vehicle Batteries	EPA 6010b Lead	500 ml	500 ml+ Plastic Container	Nitric Acid	5 ppb	14 days
Solvents, VOC / SVOC	EPA 601/602 or EPA 624 Or EPA 625	40 ml	3 VOA	HCL	Several	14 days
Curing Compounds, non pigmented	SM 2310B/2320, EPA 150.1, 601, 602, 624, 625	1000 ml	500 ml Plastic	Ice / HCL	Several	ph 24 hrs / 14 Days
Sealants, COD	EPA 410.4	500 ml	500 ml Poly	H2SO4	10 mg/l	28 days
Fertilizer, Nitrates	EPA 300.0	100 ml	500 ml Poly	Non-Req	0,10	48 hrs
Notes:						

7.7.1.7 *Data Evaluation and Reporting*

The QSP shall complete an evaluation of the water quality sample analytical results.

Runoff/downgradient results shall be compared with the associated upgradient/unaffected results and any associated run-on results. Should the runoff/downgradient sample show an increased level of the tested analyte relative to the unaffected background sample, which cannot be explained by run-on results, the BMPs, site conditions, and surrounding influences shall be assessed to determine the probable cause for the increase.

As determined by the site and data evaluation, appropriate BMPs shall be repaired or modified to mitigate discharges of non-visible pollutant concentrations. Any revisions to the BMPs shall be recorded as an amendment to the SWPPP.

The General Permit prohibits the storm water discharges that contain hazardous substances equal to or in excess of reportable quantities established in 40 C.F.R. §§ 117.3 and 302.4. The results of any non-stormwater discharge results that indicate the presence of a hazardous substance in excess of established reportable quantities shall be immediately reported to the Regional Water Board and other agencies as required by 40 C.F.R. §§ 117.3 and 302.4.

Results of non-visible pollutant monitoring shall be reported in the Annual Report.

7.7.2 Sampling and Analysis Plan for pH and Turbidity in Stormwater Runoff Discharges

Sampling and analysis of runoff for pH and turbidity is not required for Risk Level 1 projects.

7.7.3 Additional Monitoring Following an NEL Exceedance

This project is not subject to NELs.

7.7.4 Sampling and Analysis Plan for Non-Stormwater Discharges

This project is not subject to the non-stormwater sampling and analysis requirements of the General Permit because it is a Risk Level 1 project.

7.7.5 Sampling and Analysis Plan for Other Pollutants Required by the Regional Water Board

The Regional Water Board has not specified monitoring for additional pollutants.

7.7.6 Training of Sampling Personnel

Sampling personnel shall be trained to collect, maintain, and ship samples in accordance with the Surface Water Ambient Monitoring program (SWAMP) 2008 Quality Assurance Program Plan (QAPrP). Training records of designated contractor sampling personnel are provided in Appendix G: *Training Reporting Form*.

The stormwater sampler(s) and alternate(s) have received the following stormwater sampling training:

Name

Training

The stormwater sampler(s) and alternates have the following stormwater sampling experience:

Name

Experience

7.7.7 Sample Collection and Handling

7.7.7.1 Sample Collection

Samples shall be collected at the designated sampling locations shown on the Site Maps and listed in the preceding sections. Samples shall be collected, maintained and shipped in accordance with the SWAMP 2008 Quality Assurance Program Plan (QAPrP).

Grab samples shall be collected and preserved in accordance with the methods identified in preceding sections.

To maintain sample integrity and prevent cross-contamination, sample collection personnel shall follow the protocols below.

- Collect samples (for laboratory analysis) only in analytical laboratory-provided sample containers;
- Wear clean, powder-free nitrile gloves when collecting samples;
- Change gloves whenever something not known to be clean has been touched;
- Change gloves between sites;
- Decontaminate all equipment (e.g. bucket, tubing) prior to sample collection using a trisodium phosphate water wash, distilled water rinse, and final rinse with distilled water. (Dispose of wash and rinse water appropriately, i.e., do not discharge to storm drain or receiving water). Do not decontaminate laboratory provided sample containers;
- Do not smoke during sampling events;
- Never sample near a running vehicle;
- Do not park vehicles in the immediate sample collection area (even non-running vehicles);
- Do not eat or drink during sample collection; and
- Do not breathe, sneeze, or cough in the direction of an open sample container.

The most important aspect of grab sampling is to collect a sample that represents the entire runoff stream. Typically, samples are collected by dipping the collection container in the runoff flow paths and streams as noted below.

- i. For small streams and flow paths, simply dip the bottle facing upstream until full.
- ii. For larger stream that can be safely accessed, collect a sample in the middle of the flow stream by directly dipping the mouth of the bottle. Once again making sure that the opening of the bottle is facing upstream as to avoid any contamination by the sampler.
- iii. For larger streams that cannot be safely waded, pole-samplers may be needed to safely access the representative flow.
- iv. Avoid collecting samples from ponded, sluggish or stagnant water.
- v. Avoid collecting samples directly downstream from a bridge as the samples can be affected by the bridge structure or runoff from the road surface.

Note, that depending upon the specific analytical test, some containers may contain preservatives. These containers should **never** be dipped into the stream, but filled indirectly from the collection container.

7.7.7.2 *Sample Handling*

Turbidity and pH measurements must be conducted immediately. Do not store turbidity or pH samples for later measurement.

Samples for laboratory analysis must be handled as follows. Immediately following sample collection:

- Cap sample containers;
- Complete sample container labels;
- Sealed containers in a re-sealable storage bag;
- Place sample containers into an ice-chilled cooler;
- Document sample information on the *Effluent Sampling Field Log Sheet*; and
- Complete the CoC.

All samples for laboratory analysis must be maintained between 0-6 degrees Celsius during delivery to the laboratory. Samples must be kept on ice, or refrigerated, from sample collection through delivery to the laboratory. Place samples to be shipped inside coolers with ice. Make sure the sample bottles are well packaged to prevent breakage and secure cooler lids with packaging tape.

Ship samples that will be laboratory analyzed to the analytical laboratory right away. Hold times are measured from the time the sample is collected to the time the sample is analyzed. The General Permit requires that samples be received by the analytical laboratory within 48 hours of the physical sampling (unless required sooner by the analytical laboratory).

Laboratory Name: BSK Associates – Fresno
Address: 1414 Stanislaus St,
City, State Zip: Fresno, CA 93706
Telephone Number: (559) 497-2888
Point of Contact: Lisa Cardenas

7.7.7.3 *Sample Documentation Procedures*

All original data documented on sample bottle identification labels, *Effluent Sampling Field Log Sheet*, and CoCs shall be recorded using waterproof ink. These shall be considered accountable documents. If an error is made on an accountable document, the individual shall make corrections by lining through the error and entering the correct information. The erroneous information shall not be obliterated. All corrections shall be initialed and dated.

Duplicate samples shall be identified consistent with the numbering system for other samples to prevent the laboratory from identifying duplicate samples. Duplicate samples shall be identified in the *Effluent Sampling Field Log Sheet*.

Sample documentation procedures include the following:

Sample Bottle Identification Labels: Sampling personnel shall attach an identification label to each sample bottle. Sample identification shall uniquely identify each sample location.

Field Log Sheets: Sampling personnel shall complete the *Effluent Sampling Field Log Sheet* and *Receiving Water Sampling Field Log Sheet* for each sampling event, as appropriate.

Chain of Custody: Sampling personnel shall complete the CoC for each sampling event for which samples are collected for laboratory analysis. The sampler will sign the CoC when the sample(s) is turned over to the testing laboratory or courier.

7.11 *Quality Assurance and Quality Control*

An effective Quality Assurance and Quality Control (QA/QC) plan shall be implemented as part of the CSMP to ensure that analytical data can be used with confidence. QA/QC procedures to be initiated include the following:

- Field logs;
- Clean sampling techniques;
- CoCs;
- QA/QC Samples; and
- Data verification.

Each of these procedures is discussed in more detail in the following sections.

7.11.1 *Field Logs*

The purpose of field logs is to record sampling information and field observations during monitoring that may explain any uncharacteristic analytical results. Sampling information to be included in the field log include the date and time of water quality sample collection, sampling personnel, sample container identification numbers, and types of samples that were collected. Field observations should be noted in the field log for any abnormalities at the sampling location (color, odor, BMPs, etc.). Field measurements for pH and turbidity should also be recorded in the field log. A Visual Inspection Field Log, an Effluent Sampling Field Log Sheet, are included in CSMP Attachment 3 “Example Forms”.

7.11.2 *Clean Sampling Techniques*

Clean sampling techniques involve the use of certified clean containers for sample collection and clean powder-free nitrile gloves during sample collection and handling. As discussed in Section

7.7.7, adoption of a clean sampling approach will minimize the chance of field contamination and questionable data results.

7.11.3 Chain of Custody

The sample CoC is an important documentation step that tracks samples from collection through analysis to ensure the validity of the sample. Sample CoC procedures include the following:

- Proper labeling of samples;
- Use of CoC forms for all samples; and
- Prompt sample delivery to the analytical laboratory.

Analytical laboratories usually provide CoC forms to be filled out for sample containers. An example CoC is included in CSMP Attachment 3 “Example Forms”.

7.11.4 QA/QC Samples

QA/QC samples provide an indication of the accuracy and precision of the sample collection; sample handling; field measurements; and analytical laboratory methods. The following types of QA/QC will be conducted for this project:

- Field Duplicates at a frequency of 5% or 1 duplicate minimum per sampling event (Required for all sampling plans with field measurements or laboratory analysis)
- Equipment Blanks at a frequency of 1 duplicate (Only needed if equipment used to collect samples could add the pollutants to sample)
- Field Blanks at a frequency of 1 duplicate (Only required if sampling method calls for field blanks)
- Travel Blanks at a frequency of 1 duplicate (Required for sampling plans that include VOC laboratory analysis)

7.11.4.1 Field Duplicates

Field duplicates provide verification of laboratory or field analysis and sample collection. Duplicate samples shall be collected, handled, and analyzed using the same protocols as primary samples. The sample location where field duplicates are collected shall be randomly selected from the discharge locations. Duplicate samples shall be collected immediately after the primary sample has been collected. Duplicate samples must be collected in the same manner and as close in time as possible to the original sample. Duplicate samples shall not influence any evaluations or conclusion.

7.11.4.2 Equipment Blanks

Equipment blanks provide verification that equipment has not introduced a pollutant into the sample. Equipment blanks are typically collected when:

- New equipment is used;
- Equipment that has been cleaned after use at a contaminated site;
- Equipment that is not dedicated for surface water sampling is used; or
- Whenever a new lot of filters is used when sampling metals.

7.11.4.3 *Field Blanks*

Field blanks assess potential sample contamination levels that occur during field sampling activities. De-ionized water field blanks are taken to the field, transferred to the appropriate container, and treated the same as the corresponding sample type during the course of a sampling event.

7.11.4.4 *Travel Blanks*

Travel blanks assess the potential for cross-contamination of volatile constituents between sample containers during shipment from the field to the laboratory. De-ionized water blanks are taken along for the trip and held unopened in the same cooler with the VOC samples.

7.11.5 **Data Verification**

After results are received from the analytical laboratory, the QSP shall verify the data to ensure that it is complete, accurate, and the appropriate QA/QC requirements were met. Data must be verified as soon as the data reports are received. Data verification shall include:

- Check the CoC and laboratory reports.
Make sure all requested analyses were performed and all samples are accounted for in the reports.
- Check laboratory reports to make sure hold times were met and that the reporting levels meet or are lower than the reporting levels agreed to in the contract.
- Check data for outlier values and follow up with the laboratory.
Occasionally typographical errors, unit reporting errors, or incomplete results are reported and should be easily detected. These errors need to be identified, clarified, and corrected quickly by the laboratory. The QSP should especially note data that is an order of magnitude or more different than similar locations or is inconsistent with previous data from the same location.
- Check laboratory QA/QC results.
EPA establishes QA/QC checks and acceptable criteria for laboratory analyses. These data are typically reported along with the sample results. The QSP shall evaluate the reported QA/QC data to check for contamination (method, field, and equipment blanks), precision (laboratory matrix spike duplicates), and accuracy (matrix spikes and laboratory control samples). When QA/QC checks are outside acceptable ranges, the laboratory must flag the data, and usually provides an explanation of the potential impact to the sample results.
- Check the data set for outlier values and, accordingly, confirm results and re-analyze samples where appropriate.
Sample re-analysis should only be undertaken when it appears that some part of the QA/QC resulted in a value out of the accepted range. Sample results may not be discounted unless the analytical laboratory identifies the required QA/QC criteria were not met and confirms this in writing.

Field data including inspections and observations must be verified as soon as the field logs are received, typically at the end of the sampling event. Field data verification shall include:

- Check field logs to make sure all required measurements were completed and appropriately documented;
- Check reported values that appear out of the typical range or inconsistent; Follow-up immediately to identify potential reporting or equipment problems, if appropriate, recalibrate equipment after sampling;
- Verify equipment calibrations;
- Review observations noted on the field logs; and
- Review notations of any errors and actions taken to correct the equipment or recording errors.

7.12 *Records Retention*

All records of stormwater monitoring information and copies of reports (including Annual Reports) must be retained for a period of at least three years from date of submittal or longer if required by the Regional Water Board.

Results of visual monitoring, field measurements, and laboratory analyses must be kept in the SWPPP along with CoCs, and other documentation related to the monitoring.

Records are to be kept onsite while construction is ongoing. Records to be retained include:

- The date, place, and time of inspections, sampling, visual observations, and/or measurements, including precipitation;
- The individual(s) who performed the inspections, sampling, visual observation, and/or field measurements;
- The date and approximate time of field measurements and laboratory analyses;
- The individual(s) who performed the laboratory analyses;
- A summary of all analytical results, the method detection limits and reporting limits, and the analytical techniques or methods used;
- Rain gauge readings from site inspections;
- QA/QC records and results;
- Calibration records;
- Visual observation and sample collection exemption records;
- The records of any corrective actions and follow-up activities that resulted from analytical results, visual observations, or inspections

CSMP ATTACHMENT 1: WEATHER REPORTS

Place Printed NOAA weather forecasts in this attachment

CSMP ATTACHMENT 2: MONITORING RECORDS

Place completed BMP Inspection Forms, Visual Monitoring, Effluent Sampling and Receiving Water Field Logs, Monitoring Exceptions, in this Attachment.

CSMP ATTACHMENT 3: EXAMPLE FORMS

- *Rain Gauge Log Sheet*
- *Visual Inspection Field Log Sheet*
- *BMP Inspection Report*
- *NAL or NEL Exceedance Evaluations Summary Report*
- *Chain of Custody Forms*

Risk Level 1 Visual Inspection Field Log Sheet						
Date and Time of Inspection:				Report Date:		
Inspection Type:	<input type="checkbox"/> Weekly	<input type="checkbox"/> Before predicted rain	<input type="checkbox"/> During rain event	<input type="checkbox"/> Following qualifying rain event	<input type="checkbox"/> Contained stormwater release	<input type="checkbox"/> Quarterly non-stormwater
Site Information						
Construction Site Name: CUSD District Office Expansion						
Construction stage and completed activities:				Approximate area of exposed site:		
Weather and Observations						
Date Rain Predicted to Occur:				Predicted % chance of rain:		
Estimate storm beginning: <hr style="width:100%; border: 0.5px solid black;"/> (date and time)		Estimate storm duration: _____ - (hours)		Estimate time since last storm: <hr style="width:100%; border: 0.5px solid black;"/> (days or hours)	Rain gauge reading: _ <hr style="width:100%; border: 0.5px solid black;"/> (inches)	
Observations: If yes identify location						
Odors		Yes <input type="checkbox"/> No <input type="checkbox"/>				
Floating material		Yes <input type="checkbox"/> No <input type="checkbox"/>				
Suspended Material		Yes <input type="checkbox"/> No <input type="checkbox"/>				
Sheen		Yes <input type="checkbox"/> No <input type="checkbox"/>				
Discolorations		Yes <input type="checkbox"/> No <input type="checkbox"/>				
Turbidity		Yes <input type="checkbox"/> No <input type="checkbox"/>				
Site Inspections						
Outfalls or BMPs Evaluated			Deficiencies Noted			
(add additional sheets or attached detailed BMP Inspection Checklists)						
Photos Taken:		Yes <input type="checkbox"/>		No <input type="checkbox"/>		Photo Reference IDs:
Corrective Actions Identified (note if SWPPP/REAP change is needed)						
Inspector Information						

Inspector Name:	Inspector Title:
Signature:	Date:

CHAIN-OF-CUSTODY

DATE:

Lab ID:

DESTINATION LAB: ATTN: ADDRESS: Office Phone: Cell Phone:							REQUESTED ANALYSIS				Notes:		
							SAMPLED BY:						
							Contact:						
Project Name			CUSD District Office Expansion										
Client Sample ID	Sample Date	Sample Time	Sample Matrix	Container									
				#	Type	Pres.							
SENDER COMMENTS:							RELINQUISHED BY						
							Signature:						
							Print:						
							Company:						
Date:				TIME:									
LABORATORY COMMENTS:							RECEIVED BY						
							Signature:						
							Print:						
							Company:						
Date:				TIME:									

SECTION 8 REFERENCES

California Department of Toxic Substances Control, (2021). *Envirostor Database*. Retrieved from: https://www.envirostor.dtsc.ca.gov/public/profile_report?global_id=70000039

California Department of Water Resources, (2011). *Lines of Equal Elevation of Groundwater*.

CASQA 2019, *Stormwater BMP Handbook Portal: Construction*, December 2019, www.casqa.org

Project Plans and Specifications prepared by Blair, Church & Flynn Consulting Engineers and Teter Architects

State Water Resources Control Board (2010). Order 2010-0014-DWQ, NPDES General Permit No. CAS000002: National Pollutant Discharges Elimination System (NPDES) California General Permit for Storm Water Discharge Associated with Construction and Land Disturbing Activities. Available on-line at:

http://www.waterboards.ca.gov/water_issues/programs/stormwater/construction.shtml.

State Water Resources Control Board (2012). Order 2012-0006-DWQ, NPDES General Permit No. CAS000002: *National Pollutant Discharges Elimination System (NPDES) California General Permit for Storm Water Discharge Associated with Construction and Land Disturbing Activities*. Available on-line at:

http://www.waterboards.ca.gov/water_issues/programs/stormwater/construction.shtml.

United States Division of Agriculture, (2021). *Web Soil Survey*. Retrieved from:

<https://websoilsurvey.nrcs.usda.gov/app/WebSoilSurvey.aspx>

APPENDIX A: CALCULATIONS

Runoff Coefficient Calculation

Pre-Development

	C-Factor	% of Site	Effective "C"	
Graded Dirt	0.20	0%	0	
Fields w/ Weeds	0.15	96%	0.144	
Landscaping/Turf	0.15	0%	0	
Concrete/Asphalt/Roof Top	0.90	4%	0.036	
		100%	0.18	<<Effective "Pre-Development" C-Factor

Post-Development

	C-Factor	% of Site	Effective "C"	
Graded Dirt	0.20	0%	0	
Fields w/ Weeds	0.15	0%	0	
Landscaping/Turf	0.15	36%	0.054	
Concrete/Asphalt/Roof Top	0.90	64%	0.576	
		0%	0.63	<<Effective "Post-Development" C-Factor

Total Site Acreage **9.09** acres

Total Annual Rainfall **12.00** inches

Project Status	Runoff Coefficient	Site Area (acres)	Average Annual Rainfall (inches)	Average Annual Runoff (acre-feet)
Pre-Construction	0.18	9.09	12.00	1.64
Post-Construction	0.63	9.09	12.00	5.73

4.09 Difference Between the Two

Acres/Sqr-ft 2.30E-05

Pre Construction Project Area Cover			
	Sqr-ft	Acres	Percent Cover
Non-Roof Impervious	15854	0.36	4.01%
Roof (imp)	0	0.00	0.00%
Pervious	379971	8.72	95.99%
Total	395825	9.09	100.00%

Post Construction Project Area Cover			
	Sqr-ft	Acres	Percent Cover
Non-Roof Impervious	202031	4.64	51.04%
Roof (imp)	51411	1.18	12.99%
Pervious	142383	3.27	35.97%
Total	395825	9.09	100.00%

Work Area Calculations			
	Sqr-ft	Acres	Percent Cover
Graded Areas	369409	8.48	93.33%
Disturbed Areas	393740	9.04	99.47%

Rainfall Erosivity Factor Calculator for Small Construction Sites

EPA's stormwater regulations allow NPDES permitting authorities to waive NPDES permitting requirements for stormwater discharges from small construction sites if:

- the construction site disturbs less than five acres, and
- the rainfall erosivity factor ("R" in the revised universal soil loss equation, or RUSLE) value is less than five during the period of construction activity.

If your small construction project is located in an area where EPA is the permitting authority and your R factor is less than five, you qualify for a low erosivity waiver (LEW) from NPDES stormwater permitting. If your small construction project does not qualify for a waiver, then NPDES stormwater permit coverage is required. Follow the steps below to calculate your R-Factor.

LEW certifications are submitted through the NPDES eReporting Tool or "CGP-NeT". Several states that are authorized to implement the NPDES permitting program also accept LEWs. Check with your state NPDES permitting authority for more information.

- [Submit your LEW through EPA's eReporting Tool](#)
- [List of states, Indian country, and territories where EPA is the permitting authority_\(pdf\)](#)
- [Construction Rainfall Erosivity Waiver Fact Sheet](#)
- [Small Construction Waivers and Instructions_\(pdf\)](#)

The R-factor calculation can also be integrated directly into custom applications using the [R-Factor web service](#).

For questions or comments, email EPA's CGP staff at cgp@epa.gov.

 Select the estimated start and end dates of construction by clicking the boxes and using the dropdown calendar.

The period of construction activity begins at initial earth disturbance and ends with final stabilization.

Start Date: **End Date:**

 Locate your small construction project using the search box below or by clicking on the map.

Location: **Search**

+

-

Click the "Calculate R Factor" button below to calculate an R Factor for your small construction project.

Calculate R Factor

Facility Information

Start Date: 07/05/2023	Latitude: 36.8362
End Date: 07/04/2024	Longitude: -119.6828

Calculation Results

Rainfall erosivity factor (R Factor) = **26.28**

A rainfall erosivity factor of 5.0 or greater has been calculated for your site's period of construction.

You do NOT qualify for a waiver from NPDES permitting requirements and must seek Construction General Permit (CGP) coverage. If you are located in an [area where EPA is the permitting authority \(pdf\)](#), you must submit a Notice of Intent (NOI) through the [NPDES eReporting Tool \(NeT\)](#). Otherwise, you must seek coverage under your state's CGP.

Rainfall Erosivity Factor Calculator for Small Construction Sites

EPA's stormwater regulations allow NPDES permitting authorities to waive NPDES permitting requirements for stormwater discharges from small construction sites if:

- the construction site disturbs less than five acres, and
- the rainfall erosivity factor ("R" in the revised universal soil loss equation, or RUSLE) value is less than five during the period of construction activity.

If your small construction project is located in an area where EPA is the permitting authority and your R factor is less than five, you qualify for a low erosivity waiver (LEW) from NPDES stormwater permitting. If your small construction project does not qualify for a waiver, then NPDES stormwater permit coverage is required. Follow the steps below to calculate your R-Factor.

LEW certifications are submitted through the NPDES eReporting Tool or "CGP-NeT". Several states that are authorized to implement the NPDES permitting program also accept LEWs. Check with your state NPDES permitting authority for more information.

- [Submit your LEW through EPA's eReporting Tool](#)
- [List of states, Indian country, and territories where EPA is the permitting authority_\(pdf\)](#)
- [Construction Rainfall Erosivity Waiver Fact Sheet](#)
- [Small Construction Waivers and Instructions_\(pdf\)](#)

The R-factor calculation can also be integrated directly into custom applications using the [R-Factor web service](#).

For questions or comments, email EPA's CGP staff at cgp@epa.gov.

 Select the estimated start and end dates of construction by clicking the boxes and using the dropdown calendar.

The period of construction activity begins at initial earth disturbance and ends with final stabilization.

Start Date: **End Date:**

 Locate your small construction project using the search box below or by clicking on the map.

Location: **Search**

+

-

Click the "Calculate R Factor" button below to calculate an R Factor for your small construction project.

Calculate R Factor

Facility Information

Start Date: 07/05/2024	Latitude: 36.8362
End Date: 02/09/2025	Longitude: -119.6828

Calculation Results

Rainfall erosivity factor (R Factor) = **16.97**

A rainfall erosivity factor of 5.0 or greater has been calculated for your site's period of construction.

You do NOT qualify for a waiver from NPDES permitting requirements and must seek Construction General Permit (CGP) coverage. If you are located in an [area where EPA is the permitting authority \(pdf\)](#), you must submit a Notice of Intent (NOI) through the [NPDES eReporting Tool \(NeT\)](#). Otherwise, you must seek coverage under your state's CGP.

You are logged-in as: **Paige Noga**
 If this account does not belong to you, please log out.

Navigate To:

Risk

The application is organized into different tabs. Please complete all applicable tabs before submitting the form. If you want to complete the application at a later time, please click on "Save & Exit".

WDID/App ID: - 559421	Owner: Clovis Unified School District	Certified Date:
Status: Not Submitted	1470 Herndon Avenue Clovis CA 93611	Processed Date:
Order No: 2009-0009-DWQ	Site: CUSD District Expansion	NOT Effective Date:
Permit Type: Construction - NOI	Fowler Ave and Herndon Ave Clovis CA 93611	Previous ID: -

- [Owner Info](#)
[Developer Info](#)
[Site Info](#)
[Risk](#)
[Addl. Site Info](#)
[Post Construction](#)
[Billing Info](#)
[Attachments](#)
[Certification](#)
[Reports](#)
[Inspections](#)
[Print](#)
[Status History](#)
[Linked Users](#)
[NOTs](#)
[COIs](#)

SEDIMENT RISK FACTOR WORKSHEET	
Instructions: Enter R,K and LS factor values. System will calculate watershed erosion estimates and site sediment risk factor	
A. Sediment Risk	
A) R Factor Value: (What's this?)	43.25 *Erosivity Calculator
B) K Factor Value (weighted average, by area, for all site soils) (What's this?) ***If not using the SWRCB map(Populate K Factor) upload your analysis on the Attachment Tab prior to submitting to the SWRCB.	0.32 * <input type="button" value="Populate K Factor"/>
C) LS Factor (weighted average, by area, for all slopes) (What's this?) ***If not using the SWRCB map(Populate LS Factor) upload your analysis on the Attachment Tab prior to submitting to the SWRCB.	0.14357778 * <input type="button" value="Populate LS Factor"/>
Watershed Erosion Estimate (=R*K*LS) in tons/acre	
Site Sediment Risk Factor Low Sediment Risk: < 15 tons/acre Medium Sediment Risk: >= 15 and <75 tons/acre High Sediment Risk: >= 75 tons/acre	
Low	

RECEIVING WATER (RW) RISK FACTOR WORKSHEET

A. Watershed Characteristics

A.1.(a) Does the disturbed area discharge directly or indirectly to a 303(d) listed waterbody impaired by sediment? <p style="text-align: center;"><u>OR</u></p> A.1.(b) Is the disturbed area located within a sub-watershed draining to a 303(d) listed waterbody impaired by sediment? <p style="text-align: center;"><u>OR</u></p> A.2. Is the disturbed area located within a planning watershed draining to a waterbody with designated beneficial uses of COLD, SPAWN AND MIGRATORY?	<input type="button" value="Populate Receiving Water Risk"/> No <input type="text" value=""/> *	<input type="button" value="Low"/> Statewide Map of High Receiving Water Risk Watersheds
---	--	---

C. Combined Risk Level Matrix

		Sediment Risk		
		Low	Medium	High
Receiving Water Risk	Low	Level1	Level2	
	High	Level2		Level3
Project Sediment Risk:		<input type="text" value="Low"/>		
Project Receiving Water Risk:		<input type="text" value="Low"/>		
Project Combined Risk:		<input type="text" value="Level1"/>		

Fields marked with * are mandatory fields.

APPENDIX B: SITE MAPS

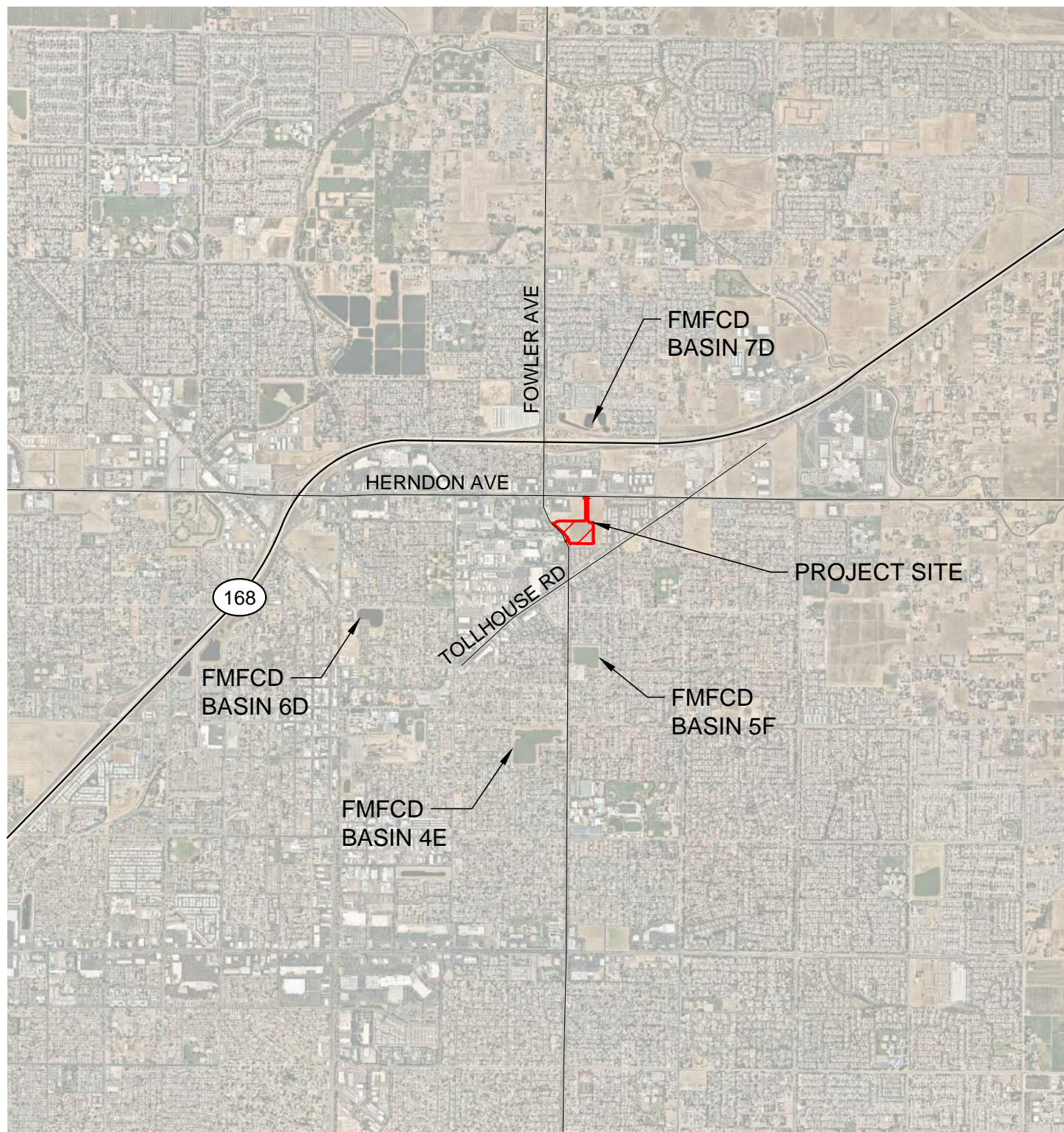

LOCATION MAP
NOT TO SCALE



SYMBOL LEGEND:



PROTECT EXISTING OFF-SITE STORM
WATER COLLECTION POINT/DRAIN
INLET PER CASQA SE-10



















PROJECT SITE
SCALE: 1"=300'



SITE LOCATION: S. OF PARKING LOT ON SE. CORNER OF FOWLER & HERNDON, CLOVIS CA 93611 | 36.83616, -119.68276 | FIGURE: 1A

 Blair, Church & Flynn Consulting Engineers 481 Clovis Avenue Suite 200 Clovis, California 93612 Tel: (509) 338-1400 Fax: (509) 338-1300	CLOVIS UNIFIED SCHOOL DISTRICT	
	STORM WATER POLLUTION PREVENTION PLAN CUSD DISTRICT OFFICE EXPANSION LOCATION MAPS	
DR. BY MG CH. BY ZH DATE 02-23-23 SCALE: AS NOTED	SHEET NO. 1 OF 5 SHEETS	

SYMBOL LEGEND:

-  PROTECT STORM WATER COLLECTION POINT/DRAIN INLET PER CASQA SE-10
-  SURFACE FLOW DIRECTION
-  PROJECT BOUNDARY
-  LOCATION OF MINIMUM SITE PERIMETER CONTROL BMP'S. REFER TO NOTE 1 AND THE SWPPP FOR BMP DETAILS AND FACT SHEETS. EXACT LOCATIONS OF THE PERIMETER SEDIMENT CONTROL BMP'S SHALL BE COORDINATED WITH THE QSP PRIOR TO INSTALLATION OR REMOVAL. (PERIMETER CONTROL EXAMPLES MAY INCLUDE FIBER ROLLS, SILT FENCE, SANDBAGS, ETC.)
-  PROPOSED OFF-SITE UTILITY INSTALLATION
-  PROPOSED STORM DRAIN PIPELINE
-  PROPOSED VALLEY GUTTER/FLOWLINE
-  PROPOSED BUILDING (IMPERVIOUS AREAS)
-  AREAS OF PROPOSED ASPHALT CONCRETE (IMPERVIOUS AREAS)
-  AREAS OF PROPOSED CONCRETE (IMPERVIOUS AREAS)
-  AREAS OF BRICK WALL (IMPERVIOUS AREAS)
-  AREAS OF PROPOSED VEGETATION (PERVIOUS AREAS)
-  AREAS TO BE STABILIZED AT CLOSEOUT IF DISTURBED
-  PROPOSED RETENTION BASIN (PERVIOUS AREAS)
-  LOCATION OF STABILIZED CONSTRUCTION ENTRANCE/EXIT PER CASQA TC-1
-  LOCATION OF STABILIZED CONSTRUCTION ROADWAY PER CASQA TC-2

STAGING AREA ITEMS:

- ① CONCRETE WASHOUT LOCATION PER CASQA WM-08
- ② LOCATION OF JOB TRAILER CONTAINING SPILL KIT AND ONSITE SWPPP
- ③ LOCATION OF RAIN GAUGE
- ④ MATERIAL STORAGE LOCATION PER CASQA WM-01
- ⑤ OVERNIGHT EQUIPMENT/VEHICLE STORAGE AND MAINTENANCE PER CASQA NS-8, NS-9 AND NS-10
- ⑥ RESTROOMS AND SANITARY FACILITIES PER CASQA WM-09
- ⑦ SOLID WASTE STORAGE LOCATION PER CASQA WM-05
- ⑧ STOCKPILE STORAGE LOCATION PER CASQW WM-03







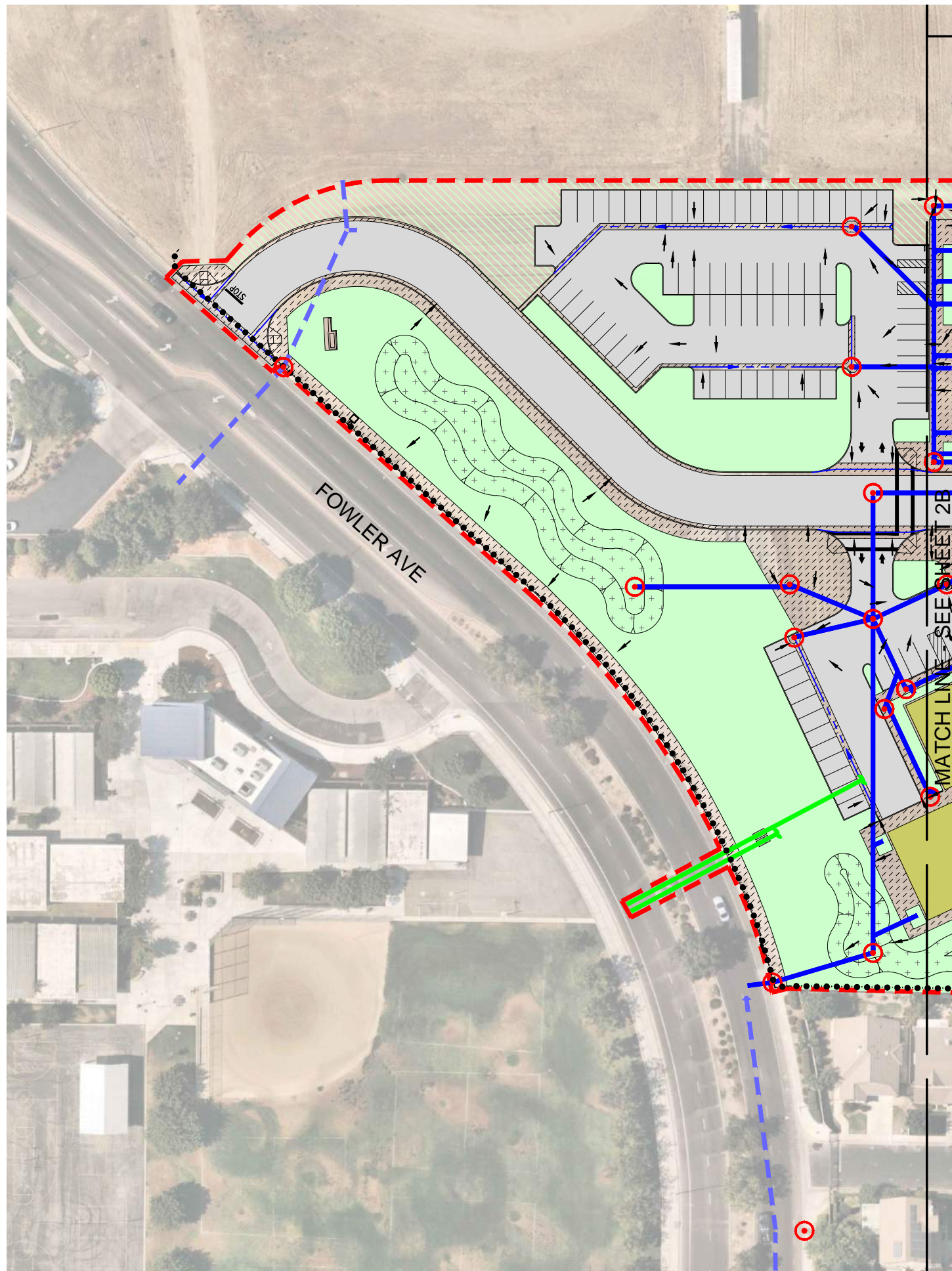



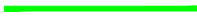

NOTES TO CONTRACTOR:

1. THE BMPS DEPICTED HEREON ARE NOT A COMPLETE LIST. REFER TO THE SWPPP APPENDIX FOR A FULL DESCRIPTION OF BMPS.
2. IN ADDITION TO THE BMPS DEPICTED HEREON, THE QSP SHALL SELECT, IMPLEMENT AND MAINTAIN AN EFFECTIVE COMBINATION OF BOTH SEDIMENT AND EROSION CONTROL BMPS THROUGHOUT THE LIFE OF THE PROJECT. PERIMETER BMPS MAY INCLUDE SILT FENCE, SANDBAGS, FIBER ROLLS, BERMS, SWALES ETC.
3. STREET SURFACES SHALL BE SWEEPED BY THE CONTRACTOR PER CASQA SE-7. VISIBLE SEDIMENT TRACKING SHALL BE SWEEPED OR VACUUMED ON A DAILY BASIS.
4. DUST CONTROL PRACTICES SHALL CONFORM WITH THE LOCAL AIR DISTRICT AND CASQA WE-1.
5. IF CONSTRUCTION IS PHASED, BMPS MAY BE INSTALLED ONLY WITHIN ACTIVE AREAS OF CONSTRUCTION. ONCE EACH PHASE OF CONSTRUCTION IS COMPLETE AND PROJECT AREA IS STABILIZED, BMPS MAY BE REMOVED WITHIN THE STABILIZED AREA.
6. THE INDICATED BMP LOCATIONS ARE RECOMMENDATIONS FOR THE CONTRACTOR AND QSP. THE QSP SHALL CONTINUALLY UPDATE FIGURE 2 WITH THE ACTUAL LOCATIONS OF ALL BMPS, AND MAINTAIN A CURRENT COPY IN THE SITE SWPPP BINDER. IF THE IMPLEMENTED BMPS ARE SIGNIFICANTLY DIFFERENT FROM THOSE INDICATED IN THE SWPPP, A SWPPP AMENDMENT SHALL BE PREPARED AND SUBMITTED TO THE WATER BOARD.
7. THE INDICATED STAGING AREAS ARE ASSUMED FOR SCHEMATIC PURPOSES ONLY, AND SHOULD BE COORDINATED WITH THE OWNER. DEPICTION OF STAGING AREAS SHALL NOT GUARANTEE USE OF THOSE AREAS WITHOUT PRIOR PERMISSION. THE QSP SHALL CONTINUALLY UPDATE FIGURE 2 WITH THE ACTUAL LOCATIONS OF ALL STAGING, AND MAINTAIN A CURRENT COPY IN THE SITE SWPPP BINDER. ALL STAGING AREAS SHALL BE FULLY STABILIZED BEFORE CLOSEOUT.
8. FINAL STABILIZATION MUST BE IMPLEMENTED AT ANY AREA THAT HAS BEEN DISTURBED, AT ANY POINT DURING CONSTRUCTION, AND MUST REACH AT LEAST 70% ESTABLISHMENT BEFORE CLOSEOUT.
9. REFER TO THE CONSTRUCTION DRAWINGS FOR MORE DETAIL.

SITE LOCATION: S. OF PARKING LOT ON SE. CORNER OF FOWLER & HERNDON, CLOVIS CA 93611 36.83616, -119.68276		FIGURE: 1B
	CONSULTANT Blair, Church & Flynn Consulting Engineers 481 Clovis Avenue Suite 200 Clovis, California 93612 Tel: (559) 326-1400 Fax: (559) 326-1200	CLOVIS UNIFIED SCHOOL DISTRICT STORM WATER POLLUTION PREVENTION PLAN CUSD DISTRICT OFFICE EXPANSION LEGENDS AND NOTES
DR. BY M.G. CH. BY Z.H. DATE 02-23-23 SCALE: AS NOTED	SHEET NO. 2 OF 5 SHEETS	

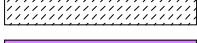
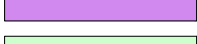

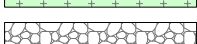

SYMBOL LEGEND:

-  PROTECT STORM WATER COLLECTION POINT/DRAIN INLET PER CASQA SE-10
-  SURFACE FLOW DIRECTION
-  PROJECT BOUNDARY
-  LOCATION OF MINIMUM SITE PERIMETER CONTROL BMP'S. REFER TO NOTE 1 AND THE SWPPP FOR BMP DETAILS AND FACT SHEETS. EXACT LOCATIONS OF THE PERIMETER SEDIMENT CONTROL BMP'S SHALL BE COORDINATED WITH THE QSP PRIOR TO INSTALLATION OR REMOVAL. (PERIMETER CONTROL EXAMPLES MAY INCLUDE FIBER ROLLS, SILT FENCE, SANDBAGS, ETC.)
-  PROPOSED OFF-SITE UTILITY INSTALLATION
-  PROPOSED STORM DRAIN PIPELINE
-  PROPOSED VALLEY GUTTER/FLOWLINE
-  PROPOSED BUILDING (IMPERVIOUS AREAS)
-  AREAS OF PROPOSED ASPHALT CONCRETE (IMPERVIOUS AREAS)
-  AREAS OF PROPOSED CONCRETE (IMPERVIOUS AREAS)
-  AREAS OF BRICK WALL (IMPERVIOUS AREAS)
-  AREAS OF PROPOSED VEGETATION (PERVIOUS AREAS)
-  AREAS TO BE STABILIZED AT CLOSEOUT IF DISTURBED
-  PROPOSED RETENTION BASIN (PERVIOUS AREAS)
-  LOCATION OF STABILIZED CONSTRUCTION ENTRANCE/EXIT PER CASQA TC-1
-  LOCATION OF STABILIZED CONSTRUCTION ROADWAY PER CASQA TC-2

STAGING AREA ITEMS:

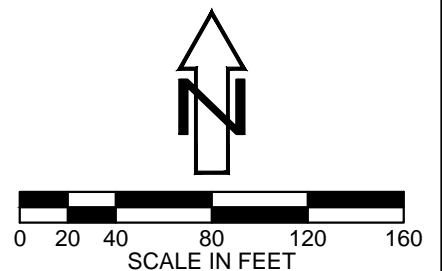





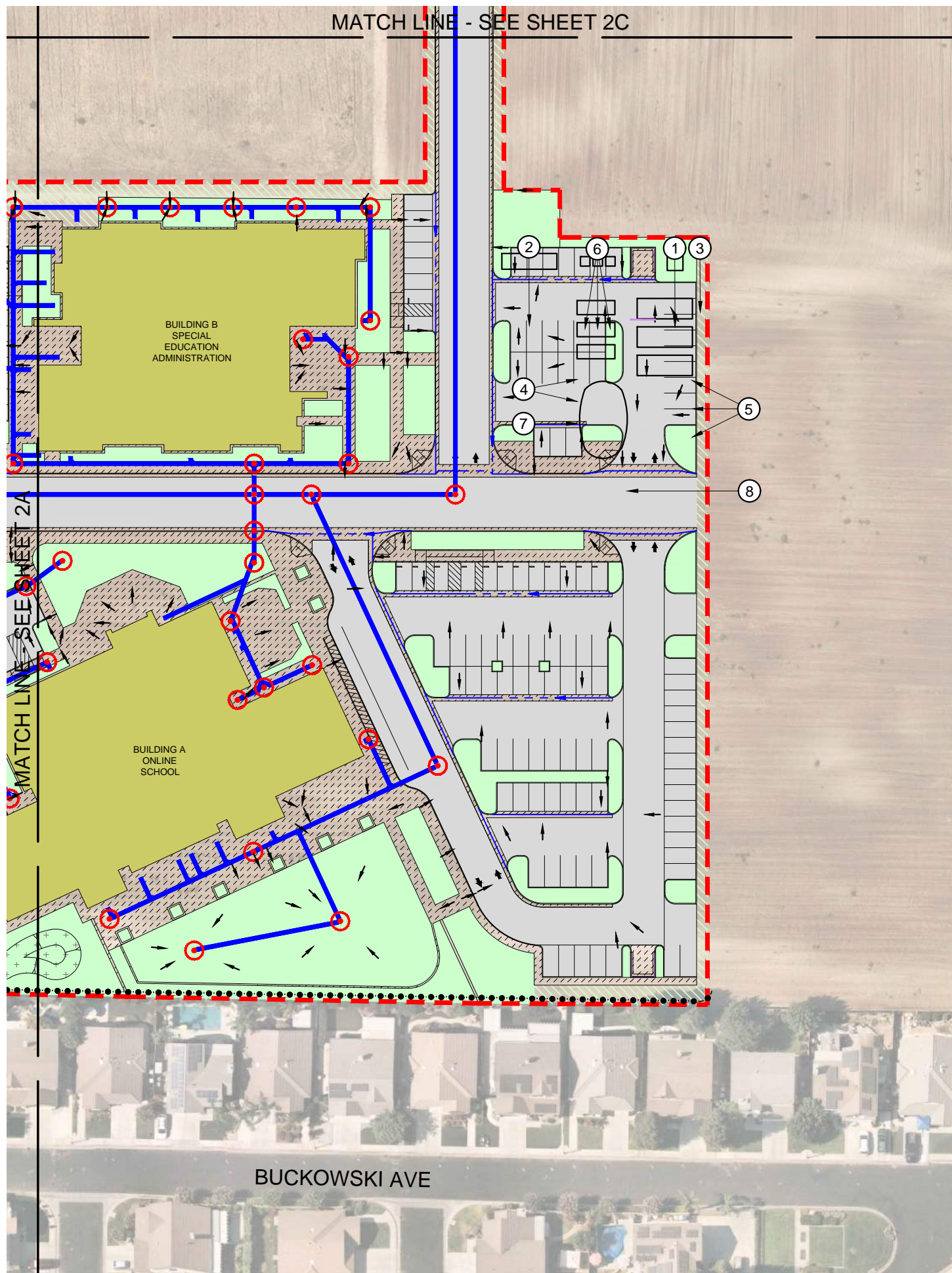





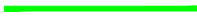

- ① CONCRETE WASHOUT LOCATION PER CASQA WM-08
- ② LOCATION OF JOB TRAILER CONTAINING SPILL KIT AND ONSITE SWPPP
- ③ LOCATION OF RAIN GAUGE
- ④ MATERIAL STORAGE LOCATION PER CASQA WM-01
- ⑤ OVERNIGHT EQUIPMENT/VEHICLE STORAGE AND MAINTENANCE PER CASQA NS-8, NS-9 AND NS-10
- ⑥ RESTROOMS AND SANITARY FACILITIES PER CASQA WM-09
- ⑦ SOLID WASTE STORAGE LOCATION PER CASQA WM-05
- ⑧ STOCKPILE STORAGE LOCATION PER CASQA WM-03

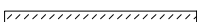
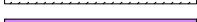

SITE LOCATION: S. OF PARKING LOT ON SE. CORNER OF FOWLER & HERNDON, CLOVIS CA 93611 36.83616, -119.68276		FIGURE: 2A
	CONSULTANT Blair, Church & Flynn Consulting Engineers 481 Clovis Avenue Suite 200 Clovis, California 93612 Tel: (509) 338-1400 Fax: (509) 338-1300	CLOVIS UNIFIED SCHOOL DISTRICT
	STORM WATER POLLUTION PREVENTION PLAN CUSD DISTRICT OFFICE EXPANSION SITE MAP	DR. BY MG CH. BY ZH DATE 02-23-23 SCALE: AS NOTED
		SHEET NO. 3 OF 5 SHEETS

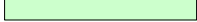

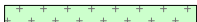
SYMBOL LEGEND:

-  PROTECT STORM WATER COLLECTION POINT/DRAIN INLET PER CASQA SE-10
-  SURFACE FLOW DIRECTION
-  PROJECT BOUNDARY
-  LOCATION OF MINIMUM SITE PERIMETER CONTROL BMP'S. REFER TO NOTE 1 AND THE SWPPP FOR BMP DETAILS AND FACT SHEETS. EXACT LOCATIONS OF THE PERIMETER SEDIMENT CONTROL BMP'S SHALL BE COORDINATED WITH THE QSP PRIOR TO INSTALLATION OR REMOVAL. (PERIMETER CONTROL EXAMPLES MAY INCLUDE FIBER ROLLS, SILT FENCE, SANDBAGS, ETC.)
-  PROPOSED OFF-SITE UTILITY INSTALLATION
-  PROPOSED STORM DRAIN PIPELINE
-  PROPOSED VALLEY GUTTER/FLOWLINE
-  PROPOSED BUILDING (IMPERVIOUS AREAS)
-  AREAS OF PROPOSED ASPHALT CONCRETE (IMPERVIOUS AREAS)
-  AREAS OF PROPOSED CONCRETE (IMPERVIOUS AREAS)
-  AREAS OF BRICK WALL (IMPERVIOUS AREAS)
-  AREAS OF PROPOSED VEGETATION (PERVIOUS AREAS)
-  AREAS TO BE STABILIZED AT CLOSEOUT IF DISTURBED
-  PROPOSED RETENTION BASIN (PERVIOUS AREAS)
-  LOCATION OF STABILIZED CONSTRUCTION ENTRANCE/EXIT PER CASQA TC-1
-  LOCATION OF STABILIZED CONSTRUCTION ROADWAY PER CASQA TC-2

STAGING AREA ITEMS:

- ① CONCRETE WASHOUT LOCATION PER CASQA WM-08
- ② LOCATION OF JOB TRAILER CONTAINING SPILL KIT AND ONSITE SWPPP
- ③ LOCATION OF RAIN GAUGE
- ④ MATERIAL STORAGE LOCATION PER CASQA WM-01
- ⑤ OVERNIGHT EQUIPMENT/VEHICLE STORAGE AND MAINTENANCE PER CASQA NS-8, NS-9 AND NS-10
- ⑥ RESTROOMS AND SANITARY FACILITIES PER CASQA WM-09
- ⑦ SOLID WASTE STORAGE LOCATION PER CASQA WM-05
- ⑧ STOCKPILE STORAGE LOCATION PER CASQW WM-03

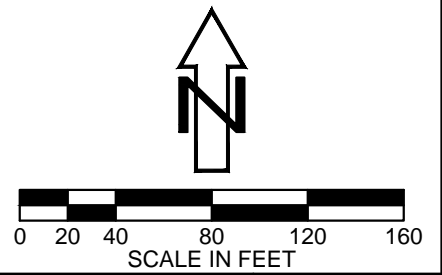

SITE LOCATION: S. OF PARKING LOT ON SE. CORNER OF FOWLER & HERNDON, CLOVIS CA 93611 | 36.83616, -119.68276 | FIGURE: 2B

	CONSULTANT Blair, Church & Flynn Consulting Engineers 481 Clovis Avenue Suite 200 Clovis, California 93612 Tel: (509) 328-1400 Fax: (509) 328-1200	CLOVIS UNIFIED SCHOOL DISTRICT	
	STORM WATER POLLUTION PREVENTION PLAN CUSD DISTRICT OFFICE EXPANSION SITE MAP		DR. BY MG CH. BY ZH DATE 02-23-23 SCALE: AS NOTED
			SHEET NO. 4 OF 5 SHEETS

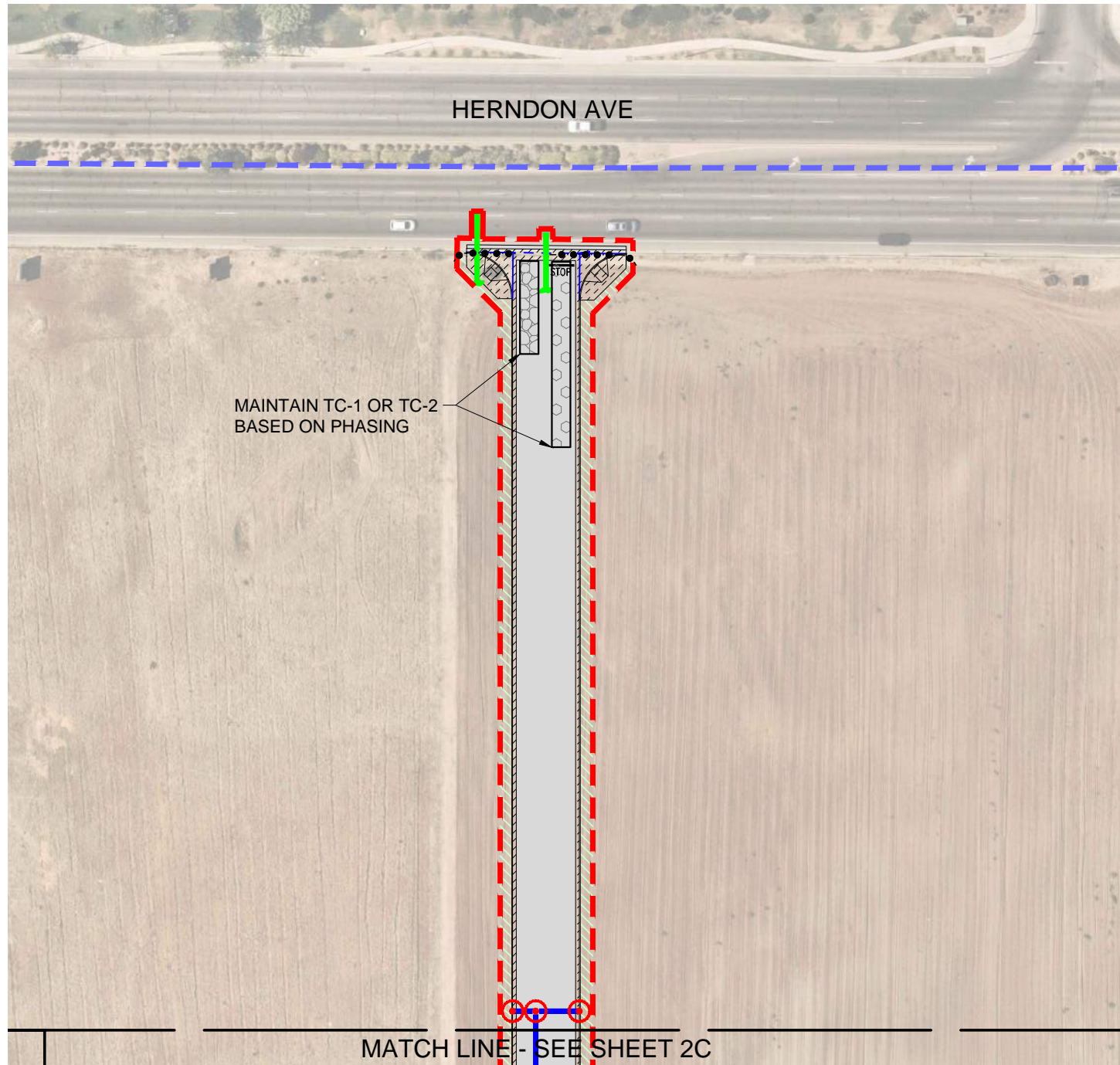

SYMBOL LEGEND:

- PROTECT STORM WATER COLLECTION POINT/DRAIN INLET PER CASQA SE-10
- SURFACE FLOW DIRECTION
- PROJECT BOUNDARY
- LOCATION OF MINIMUM SITE PERIMETER CONTROL BMP'S. REFER TO NOTE 1 AND THE SWPPP FOR BMP DETAILS AND FACT SHEETS. EXACT LOCATIONS OF THE PERIMETER SEDIMENT CONTROL BMP'S SHALL BE COORDINATED WITH THE QSP PRIOR TO INSTALLATION OR REMOVAL. (PERIMETER CONTROL EXAMPLES MAY INCLUDE FIBER ROLLS, SILT FENCE, SANDBAGS, ETC.)
- PROPOSED OFF-SITE UTILITY INSTALLATION
- PROPOSED STORM DRAIN PIPELINE
- PROPOSED VALLEY GUTTER/FLOWLINE
- PROPOSED BUILDING (IMPERVIOUS AREAS)
- AREAS OF PROPOSED ASPHALT CONCRETE (IMPERVIOUS AREAS)
- AREAS OF PROPOSED CONCRETE (IMPERVIOUS AREAS)
- AREAS OF BRICK WALL (IMPERVIOUS AREAS)
- AREAS OF PROPOSED VEGETATION (PERVIOUS AREAS)
- AREAS TO BE STABILIZED AT CLOSEOUT IF DISTURBED
- PROPOSED RETENTION BASIN (PERVIOUS AREAS)
- LOCATION OF STABILIZED CONSTRUCTION ENTRANCE/EXIT PER CASQA TC-1
- LOCATION OF STABILIZED CONSTRUCTION ROADWAY PER CASQA TC-2

STAGING AREA ITEMS:

- ① CONCRETE WASHOUT LOCATION PER CASQA WM-08
- ② LOCATION OF JOB TRAILER CONTAINING SPILL KIT AND ONSITE SWPPP
- ③ LOCATION OF RAIN GAUGE
- ④ MATERIAL STORAGE LOCATION PER CASQA WM-01
- ⑤ OVERNIGHT EQUIPMENT/VEHICLE STORAGE AND MAINTENANCE PER CASQA NS-8, NS-9 AND NS-10
- ⑥ RESTROOMS AND SANITARY FACILITIES PER CASQA WM-09
- ⑦ SOLID WASTE STORAGE LOCATION PER CASQA WM-05
- ⑧ STOCKPILE STORAGE LOCATION PER CASQA WM-03

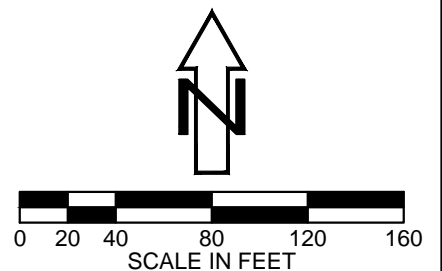

SITE LOCATION: S. OF PARKING LOT ON SE. CORNER OF FOWLER & HERNDON, CLOVIS CA 93611 36.83616, -119.68276				FIGURE: 2C
	CONSULTANT Blair, Church & Flynn Consulting Engineers 481 Clovis Avenue Suite 200 Clovis, California 93612 Tel: (509) 338-1400 Fax: (509) 338-1300	CLOVIS UNIFIED SCHOOL DISTRICT		
	STORM WATER POLLUTION PREVENTION PLAN CUSD DISTRICT OFFICE EXPANSION SITE MAP		DR. BY MG CH. BY ZH DATE 02-23-23 SCALE: AS NOTED	SHEET NO. 5 OF 5 SHEETS

APPENDIX C: PERMIT REGISTRATION DOCUMENTS

Permit Registration Documents

Notice of Intent

Change of Information (as applicable)

Annual Report(s)



State Water Resources Control Board
NOTICE OF INTENT
 GENERAL PERMIT TO DISCHARGE STORM WATER
 ASSOCIATED WITH CONSTRUCTION ACTIVITY
 (WQ ORDER No. 2009-0009-DWQ)



WDID: 5F10C401070

Risk Level: Level1

Property Owner Information

Type: Special District

Name: Clovis Unified School District
 Address: 1470 Herndon Avenue
 Address 2: _____
 City/State/Zip: Clovis CA 93611

Contact Name: Denver Stairs
 Title: Assistant Superintendent
 Phone Number: 559-327-9000
 Email Address: denverstairs@cusd.com

Contractor/Developer Information

Name: Clovis Unified School District
 Address: 1470 Herndon Avenue
 Address 2: _____
 City/State/Zip: Clovis CA 93611

Contact Name: Denver Stairs
 Title: Assistant Superintendent
 Phone Number: 559-327-9000
 Email Address: denverstairs@cusd.com

Construction Site Information

Contact Name: Denver Stairs

Title: Assistant Superintendent

Site Name: CUSD District Expansion

Address: Fowler Ave and Herndon Ave

City/State/Zip: Clovis CA 93611

Site Phone #: 559-327-9000

County: Fresno

Email Address: denverstairs@cusd.com

Latitude: 36.83616 Longitude: -119.68276

Construction Start: July 05, 2023

Total Size of Construction Area: 9.09 Acres

Complete Grading: _____

Total Area to be Disturbed: 9.04 Acres

Final Stabilization: February 09, 2025

Risk Values

R: 43.25 K: 0.32 LS: 0.14 Beneficial Uses/303(d): No

Type of Construction: _____ *Other: School District Office

Receiving Water: FMFCD Basin 5F, FMFCD Basin 6D

Qualified SWPPP Developer: Paige Noga Certification #: 00839

RWQCB Jurisdiction: Region 5F - Fresno

Phone: 559-445-5116

Email: r5f_stormwater@waterboards.ca.gov

Certification

Name: Denver Stairs Date: June 22, 2023

Title: Assistant Superintendent



State Water Resources Control Board
NOTICE OF INTENT
GENERAL PERMIT TO DISCHARGE STORM WATER
ASSOCIATED WITH CONSTRUCTION ACTIVITY
(WQ ORDER No. 2009-0009-DWQ)



WDID: 5F10C401070

Post Construction Information

Is the project located within a permitted Phase I or Phase II Municipal Separate Storm Sewer System?: _____



State Water Resources Control Board

Approved Date: June 28, 2023

Denver Stairs
Clovis Unified School District
1470 Herndon Avenue
Clovis CA 93611

RECEIPT OF YOUR NOTICE OF INTENT (NOI)

The State Water Resources Control Board (State Water Board) has received and processed your NOI to comply with the terms of the General Permit to Discharger Storm Water Associated with Construction Activity. Accordingly, you are required to comply with the permit requirements.

The Waste Discharger Identification (WDID) number is: **5F10C401070** Please use this number in any future communication regarding this permit.

OWNER:	SITE DESCRIPTION
DEVELOPER:	Clovis Unified School District
SITE INFORMATION:	Clovis Unified School District
	CUSD District Expansion
	Fowler Ave and Herndon Ave
	Clovis
TOTAL DISTURBED ACRES:	9.04
START DATE:	July 05, 2023
COMPLETION DATE:	February 09, 2025
COUNTY:	Fresno

When the Owner changes , a new NOI, site map, and fee must be submitted by the new Owner. As the previous owner, you are required to submit a Notice of Termination (NOT) to the local Regional Water Board stating you no longer own or operate the Site and coverage under the General Permit is not required. Unless notified, you will continue and are responsible to pay the annual fee invoiced each April.

If you have any questions regarding permit requirements, please contact your Regional Water Board at 559-445-5116 . Please visit the storm water web site at http://www.waterboards.ca.gov/water_issues/programs/stormwater/ to obtain an NOT and other storm water related information and forms.

Sincerely,

Storm Water Section
Division of Water Quality

APPENDIX D: CONSTRUCTION ACTIVITIES, MATERIALS USED, AND ASSOCIATED POLLUTANTS

Table D.1 Construction Activities and Associated Pollutants

Phase	Activity	Associated Materials or Pollutants
Demolition, Grading and Land Development	<ul style="list-style-type: none"> • Saw cut, crush, and remove existing concrete improvements • Saw cut, break up, and remove existing asphalt pavement • Remove trees, stump and roots • Remove turf and vegetation • Distribute material at designated areas • Deliver and empty trash bins • Deliver and service portable outhouses to site • Deliver materials to site and store in containers • Deliver equipment to site • Park equipment during off hours, refuel, check fluid levels, grease, service and repair (oil, hydraulics, cooling fluid, brake fluid, power steering fluid, etc.) • Import fill material • Excavate and compact areas 	<ul style="list-style-type: none"> • Construction equipment fluids • Concrete rubble and dust • Saw cut wastewater • Sediment from erosion • Spills • Septic spills, cleaning fluids, and washout • Trash • Fueling drips and spills (gasoline, diesel) • Operating fluid drips and spills (oil, hydraulic, coolant, brake, power steering, etc.) • Grease drips
Landscaping and Site Stabilization Phase	<ul style="list-style-type: none"> • Deliver materials to site • Deliver mulch material to site • Excavate trenches • Install water irrigation pipelines, valves, emitters and bubblers • Install controller electrical service and valve control wires • Install valve boxes • Backfill and compact trenches • Blow lines and test sytem • Plant shrubs and trees • Hydroseed, as required 	<ul style="list-style-type: none"> • Residue from materials • Mulches • Construction equipment fluids • Sediments • Shavings from conduit material • Wastewater and chlorinated water • PVC pipe dust, primer, and glue • Fertilizers • Herbicides • Trash

Table D.1 Construction Activities and Associated Pollutants

Phase	Activity	Associated Materials or Pollutants
Streets and Utilities Phase	<ul style="list-style-type: none"> • Excavate trenches • Install pipelines, laterals, and conduit • Install manholes and utility structures • Install inlets, cleanouts, valves, and conductors • Backfill and compact trenches • Install trench surface restoration • Excavate and compact subgrade • Install and compact base materials • Apply paint binder • Install forms and guide wires • Install concrete and concrete improvements • Install emulsion sealer • Paint pavement striping and markings 	<ul style="list-style-type: none"> • Construction equipment fluids • Concrete paste and curing compound • Concrete and grout washout • Joint and form lubricants • Paints, thinners, and solvents • Sediments • Shavings from conduit material and sawdust • Trash • Wastewater and chlorinated water
Vertical Construction Phase	<ul style="list-style-type: none"> • Excavate building foundations • Distribute excavated materials as onsite fill • Construct foundation, building walls, and roof • Install building plumbing • Construct building exterior covering and interior • Install insulation and finish system • Apply trim accessories, primer, sealer, and weather resistant barrier coating • Install windows, electrical wiring, cabinets, and flooring • Install building HVAC • Texture walls, paint interiors and building • Touch-up painting and clean exposed finished surfaces 	<ul style="list-style-type: none"> • Construction equipment fluids • Sediments • Concrete, grout, and stucco washout • Adhesives, cleaners, and sealants • Solder, lead, and heavy metal shavings • Cutting oil and welding slag • Steel and aluminum grindings • Roofing and flooring material trash • Sheetrock dust and sawdust • Insulation fibers • Ceramic tile dust and wash off water • Paint, lacquers, varnishes, thinners, stripping agents, sanding dust, stripping residue, paint washout, spills • Freon spills • Trash

Categories per CASQA BMP Handbook (i.e., Sediment, Nutrients, Bacteria and Viruses, Oil and Grease, Metals, Synthetic Organics, Pesticides, Gross Pollutants, and Vector Production)

***APPENDIX E: CASQA STORMWATER BMP HANDBOOK
PORTAL: CONSTRUCTION FACT SHEETS***

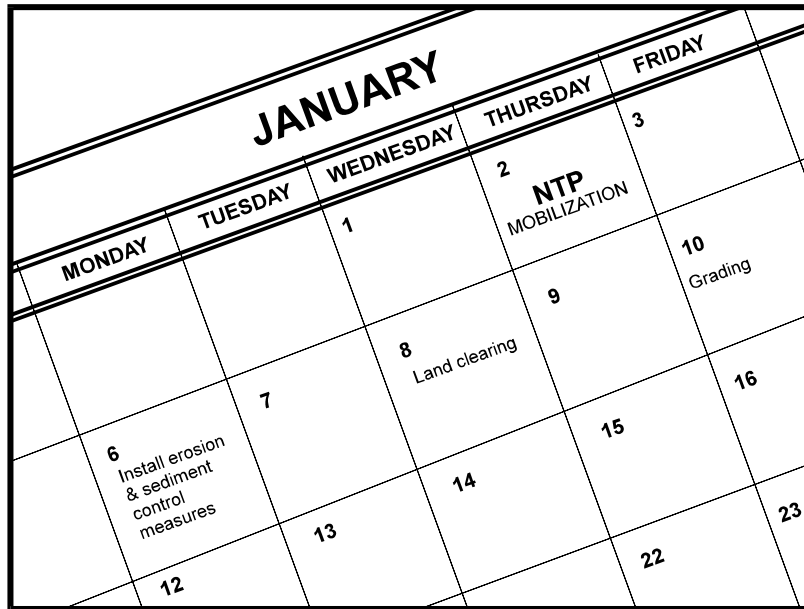

Description and Purpose

Scheduling is the development of a written plan that includes sequencing of construction activities and the implementation of BMPs such as erosion control and sediment control while taking local climate (rainfall, wind, etc.) into consideration. The purpose is to reduce the amount and duration of soil exposed to erosion by wind, rain, runoff, and vehicle tracking, and to perform the construction activities and control practices in accordance with the planned schedule.

Suitable Applications

Proper sequencing of construction activities to reduce erosion potential should be incorporated into the schedule of every construction project especially during rainy season. Use of other, more costly yet less effective, erosion and sediment control BMPs may often be reduced through proper construction sequencing.

Limitations

- Environmental constraints such as nesting season prohibitions reduce the full capabilities of this BMP.

Implementation

- Avoid rainy periods. Schedule major grading operations during dry months when practical. Allow enough time before rainfall begins to stabilize the soil with vegetation or physical means or to install sediment trapping devices.
- Plan the project and develop a schedule showing each phase of construction. Clearly show how the rainy season relates

Categories

EC	Erosion Control	<input checked="" type="checkbox"/>
SE	Sediment Control	<input checked="" type="checkbox"/>
TC	Tracking Control	<input checked="" type="checkbox"/>
WE	Wind Erosion Control	<input checked="" type="checkbox"/>
NS	Non-Stormwater Management Control	
WM	Waste Management and Materials Pollution Control	

Legend:

- Primary Objective
- Secondary Objective

Targeted Constituents

Sediment	<input checked="" type="checkbox"/>
Nutrients	
Trash	
Metals	
Bacteria	
Oil and Grease	
Organics	

Potential Alternatives

None

If User/Subscriber modifies this fact sheet in any way, the CASQA name/logo and footer below must be removed from each page and not appear on the modified version.



to soil disturbing and re-stabilization activities. Incorporate the construction schedule into the SWPPP.

- Include on the schedule, details on the rainy season implementation and deployment of:
 - Erosion control BMPs
 - Sediment control BMPs
 - Tracking control BMPs
 - Wind erosion control BMPs
 - Non-stormwater BMPs
 - Waste management and materials pollution control BMPs
- Include dates for activities that may require non-stormwater discharges such as dewatering, sawcutting, grinding, drilling, boring, crushing, blasting, painting, hydro-demolition, mortar mixing, pavement cleaning, etc.
- Work out the sequencing and timetable for the start and completion of each item such as site clearing and grubbing, grading, excavation, paving, foundation pouring utilities installation, etc., to minimize the active construction area during the rainy season.
 - Sequence trenching activities so that most open portions are closed before new trenching begins.
 - Incorporate staged seeding and re-vegetation of graded slopes as work progresses.
 - Schedule establishment of permanent vegetation during appropriate planting time for specified vegetation.
- Non-active areas should be stabilized as soon as practical after the cessation of soil disturbing activities or one day prior to the onset of precipitation.
- Monitor the weather forecast for rainfall.
- When rainfall is predicted, adjust the construction schedule to allow the implementation of soil stabilization and sediment treatment controls on all disturbed areas prior to the onset of rain.
- Be prepared year round to deploy erosion control and sediment control BMPs. Erosion may be caused during dry seasons by un-seasonal rainfall, wind, and vehicle tracking. Keep the site stabilized year round, and retain and maintain rainy season sediment trapping devices in operational condition.
- Apply permanent erosion control to areas deemed substantially complete during the project's defined seeding window.

Costs

Construction scheduling to reduce erosion may increase other construction costs due to reduced economies of scale in performing site grading. The cost effectiveness of scheduling techniques should be compared with the other less effective erosion and sedimentation controls to achieve a cost effective balance.

Inspection and Maintenance

- Verify that work is progressing in accordance with the schedule. If progress deviates, take corrective actions.
- Amend the schedule when changes are warranted.
- Amend the schedule prior to the rainy season to show updated information on the deployment and implementation of construction site BMPs.

References

Stormwater Quality Handbooks Construction Site Best Management Practices (BMPs) Manual, State of California Department of Transportation (Caltrans), November 2000.

Stormwater Management for Construction Activities Developing Pollution Prevention Plans and Best Management Practices (EPA 832-R-92-005), U.S. Environmental Protection Agency, Office of Water, September 1992.

Preservation Of Existing Vegetation EC-2

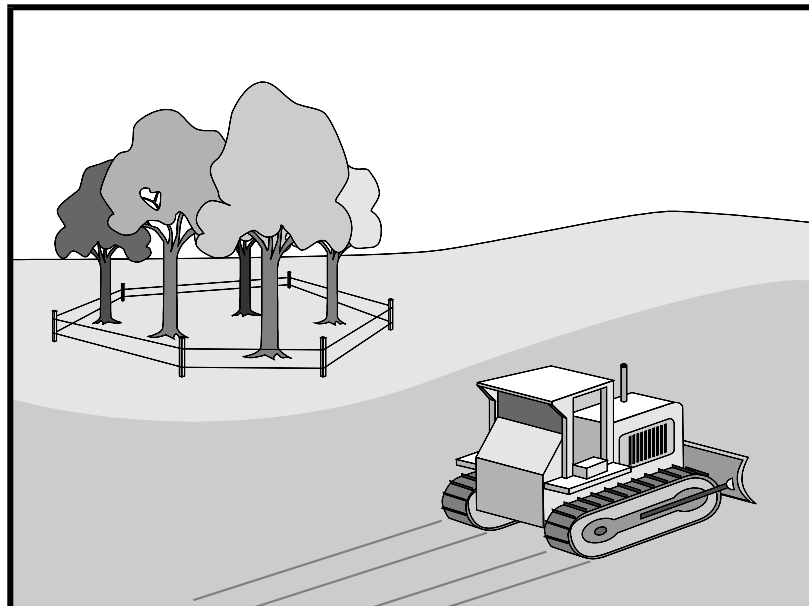

Description and Purpose

Carefully planned preservation of existing vegetation minimizes the potential of removing or injuring existing trees, vines, shrubs, and grasses that protect soil from erosion.

Suitable Applications

Preservation of existing vegetation is suitable for use on most projects. Large project sites often provide the greatest opportunity for use of this BMP. Suitable applications include the following:

- Areas within the site where no construction activity occurs, or occurs at a later date. This BMP is especially suitable to multi year projects where grading can be phased.
- Areas where natural vegetation exists and is designated for preservation. Such areas often include steep slopes, watercourse, and building sites in wooded areas.
- Areas where local, state, and federal government require preservation, such as vernal pools, wetlands, marshes, certain oak trees, etc. These areas are usually designated on the plans, or in the specifications, permits, or environmental documents.
- Where vegetation designated for ultimate removal can be temporarily preserved and be utilized for erosion control and sediment control.

Categories

EC	Erosion Control	<input checked="" type="checkbox"/>
SE	Sediment Control	
TC	Tracking Control	
WE	Wind Erosion Control	
NS	Non-Stormwater Management Control	
WM	Waste Management and Materials Pollution Control	

Legend:

- Primary Objective
- Secondary Objective

Targeted Constituents

Sediment	<input checked="" type="checkbox"/>
Nutrients	
Trash	
Metals	
Bacteria	
Oil and Grease	
Organics	

Potential Alternatives

None

If User/Subscriber modifies this fact sheet in any way, the CASQA name/logo and footer below must be removed from each page and not appear on the modified version.



Preservation Of Existing Vegetation EC-2

Limitations

- Requires forward planning by the owner/developer, contractor, and design staff.
- Limited opportunities for use when project plans do not incorporate existing vegetation into the site design.
- For sites with diverse topography, it is often difficult and expensive to save existing trees while grading the site satisfactory for the planned development.

Implementation

The best way to prevent erosion is to not disturb the land. In order to reduce the impacts of new development and redevelopment, projects may be designed to avoid disturbing land in sensitive areas of the site (e.g., natural watercourses, steep slopes), and to incorporate unique or desirable existing vegetation into the site's landscaping plan. Clearly marking and leaving a buffer area around these unique areas during construction will help to preserve these areas as well as take advantage of natural erosion prevention and sediment trapping.

Existing vegetation to be preserved on the site must be protected from mechanical and other injury while the land is being developed. The purpose of protecting existing vegetation is to ensure the survival of desirable vegetation for shade, beautification, and erosion control. Mature vegetation has extensive root systems that help to hold soil in place, thus reducing erosion. In addition, vegetation helps keep soil from drying rapidly and becoming susceptible to erosion. To effectively save existing vegetation, no disturbances of any kind should be allowed within a defined area around the vegetation. For trees, no construction activity should occur within the drip line of the tree.

Timing

- Provide for preservation of existing vegetation prior to the commencement of clearing and grubbing operations or other soil disturbing activities in areas where no construction activity is planned or will occur at a later date.

Design and Layout

- Mark areas to be preserved with temporary fencing. Include sufficient setback to protect roots.
 - Orange colored plastic mesh fencing works well.
 - Use appropriate fence posts and adequate post spacing and depth to completely support the fence in an upright position.
- Locate temporary roadways, stockpiles, and layout areas to avoid stands of trees, shrubs, and grass.
- Consider the impact of grade changes to existing vegetation and the root zone.
- Maintain existing irrigation systems where feasible. Temporary irrigation may be required.
- Instruct employees and subcontractors to honor protective devices. Prohibit heavy equipment, vehicular traffic, or storage of construction materials within the protected area.

Preservation Of Existing Vegetation EC-2

Costs

There is little cost associated with preserving existing vegetation if properly planned during the project design, and these costs may be offset by aesthetic benefits that enhance property values. During construction, the cost for preserving existing vegetation will likely be less than the cost of applying erosion and sediment controls to the disturbed area. Replacing vegetation inadvertently destroyed during construction can be extremely expensive, sometimes in excess of \$10,000 per tree.

Inspection and Maintenance

During construction, the limits of disturbance should remain clearly marked at all times. Irrigation or maintenance of existing vegetation should be described in the landscaping plan. If damage to protected trees still occurs, maintenance guidelines described below should be followed:

- Verify that protective measures remain in place. Restore damaged protection measures immediately.
- Serious tree injuries shall be attended to by an arborist.
- Damage to the crown, trunk, or root system of a retained tree shall be repaired immediately.
- Trench as far from tree trunks as possible, usually outside of the tree drip line or canopy. Curve trenches around trees to avoid large roots or root concentrations. If roots are encountered, consider tunneling under them. When trenching or tunneling near or under trees to be retained, place tunnels at least 18 in. below the ground surface, and not below the tree center to minimize impact on the roots.
- Do not leave tree roots exposed to air. Cover exposed roots with soil as soon as possible. If soil covering is not practical, protect exposed roots with wet burlap or peat moss until the tunnel or trench is ready for backfill.
- Cleanly remove the ends of damaged roots with a smooth cut.
- Fill trenches and tunnels as soon as possible. Careful filling and tamping will eliminate air spaces in the soil, which can damage roots.
- If bark damage occurs, cut back all loosened bark into the undamaged area, with the cut tapered at the top and bottom and drainage provided at the base of the wood. Limit cutting the undamaged area as much as possible.
- Aerate soil that has been compacted over a trees root zone by punching holes 12 in. deep with an iron bar, and moving the bar back and forth until the soil is loosened. Place holes 18 in. apart throughout the area of compacted soil under the tree crown.
- Fertilization
 - Fertilize stressed or damaged broadleaf trees to aid recovery.
 - Fertilize trees in the late fall or early spring.

Preservation Of Existing Vegetation EC-2

- Apply fertilizer to the soil over the feeder roots and in accordance with label instructions, but never closer than 3 ft to the trunk. Increase the fertilized area by one-fourth of the crown area for conifers that have extended root systems.
- Retain protective measures until all other construction activity is complete to avoid damage during site cleanup and stabilization.

References

County of Sacramento Tree Preservation Ordinance, September 1981.

Stormwater Quality Handbooks Construction Site Best Management Practices (BMPs) Manual, State of California Department of Transportation (Caltrans), November 2000.

Stormwater Management of the Puget Sound Basin, Technical Manual, Publication #91-75, Washington State Department of Ecology, February 1992.

Water Quality Management Plan for The Lake Tahoe Region, Volume II, Handbook of Management Practices, Tahoe Regional Planning Agency, November 1988.

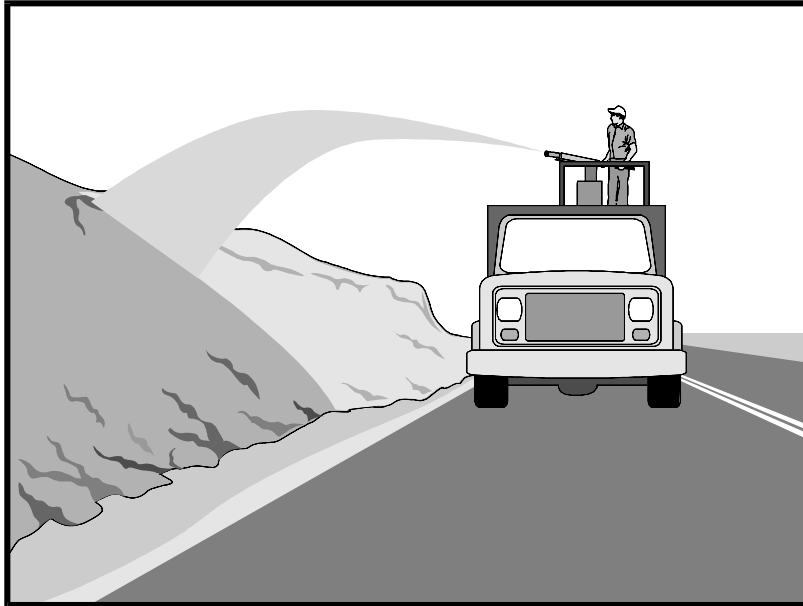

Description and Purpose

Hydraulic Mulch consists of various types of fibrous materials mixed with water and sprayed onto the soil surface in slurry form to provide a layer of temporary protection from wind and water erosion.

Suitable Applications

Hydraulic mulch as a temporary, stand alone, erosion control BMP is suitable for disturbed areas that require temporary protection from wind and water erosion until permanent soil stabilization activities commence. Examples include:

- Rough-graded areas that will remain inactive for longer than permit-required thresholds (e.g., 14 days) or otherwise require stabilization to minimize erosion or prevent sediment discharges.
- Soil stockpiles.
- Slopes with exposed soil between existing vegetation such as trees or shrubs.
- Slopes planted with live, container-grown vegetation or plugs.
- Slopes burned by wildfire.

Categories

EC	Erosion Control	<input checked="" type="checkbox"/>
SE	Sediment Control	<input type="checkbox"/>
TC	Tracking Control	<input type="checkbox"/>
WE	Wind Erosion Control	<input checked="" type="checkbox"/>
NS	Non-Stormwater Management Control	<input type="checkbox"/>
WM	Waste Management and Materials Pollution Control	<input type="checkbox"/>

Legend:

- Primary Category
- Secondary Category

Targeted Constituents

Sediment	<input checked="" type="checkbox"/>
Nutrients	<input type="checkbox"/>
Trash	<input type="checkbox"/>
Metals	<input type="checkbox"/>
Bacteria	<input type="checkbox"/>
Oil and Grease	<input type="checkbox"/>
Organics	<input type="checkbox"/>

Potential Alternatives

- EC-4 Hydroseeding
- EC-5 Soil Binders
- EC-6 Straw Mulch
- EC-7 Geotextiles and Mats
- EC-8 Wood Mulching
- EC-14 Compost Blanket
- EC-16 Non-Vegetative Stabilization

If User/Subscriber modifies this fact sheet in any way, the CASQA name/logo and footer below must be removed from each page and not appear on the modified version.



Hydraulic mulch can also be applied to augment other erosion control BMPs such as:

- In conjunction with straw mulch (see EC-6 Straw Mulch) where the rate of hydraulic mulch is reduced to 100-500 lbs per acre and the slurry is applied over the straw as a tackifying agent to hold the straw in place.
- Supplemental application of soil amendments, such as fertilizer, lime, gypsum, soil bio-stimulants or compost.

Limitations

In general, hydraulic mulch is not limited by slope length, gradient or soil type. However, the following limitations typically apply:

- Most hydraulic mulch applications, particularly bonded fiber matrices (BFMs), require at least 24 hours to dry before rainfall occurs.
- Temporary applications (i.e., without a vegetative component) may require a second application in order to remain effective for an entire rainy season.
- Treatment areas must be accessible to hydraulic mulching equipment.
- Availability of water sources in remote areas for mixing and application.
- As a stand-alone temporary BMP, hydraulic mulches may need to be re-applied to maintain their erosion control effectiveness, typically after 6-12 months depending on the type of mulch used.
- Availability of hydraulic mulching equipment may be limited just prior to the rainy season and prior to storms due to high demand.
- Cellulose fiber mulches alone may not perform well on steep slopes or in course soils.
- This BMP consists of a mixture of several constituents (e.g., fibers/mulches, tackifiers, and other chemical constituents), some of which may be proprietary and may come pre-mixed by the manufacturer. The water quality impacts of these constituents are relatively unknown and some may have water quality impacts due to their chemical makeup. Refer to specific chemical properties identified in the product Material Safety Data Sheet; products should be evaluated for project-specific implementation by the SWPPP Preparer. Refer to factsheet EC-05 for further guidance on selecting soil binders.

Implementation

- Where feasible, it is preferable to prepare soil surfaces prior to application by roughening embankments and fill areas with a crimping or punching type roller or by track walking.
- The majority of hydraulic mulch applications do not necessarily require surface/soil preparation (See EC-15 Soil Preparation) although in almost every case where re-vegetation is included as part of the practice, soil preparation can be beneficial. One of the advantages of hydraulic mulch over other erosion control methods is that it can be applied in areas where soil preparation is precluded by site conditions, such as steep slopes, rocky soils, or inaccessibility.

- Avoid mulch over spray onto roads, sidewalks, drainage channels, existing vegetation, etc.
- Hydraulic mulching is generally performed utilizing specialized machines that have a large water-holding/mixing tank and some form of mechanical agitation or other recirculation method to keep water, mulch and soil amendments in suspension. The mixed hydraulic slurry can be applied from a tower sprayer on top of the machine or by extending a hose to areas remote from the machine.
- Where possible apply hydraulic mulch from multiple directions to adequately cover the soil. Application from a single direction can result in shadowing, uneven coverage and failure of the BMP.
- Hydraulic mulch can also include a vegetative component, such as seed, rhizomes, or stolons (see EC-4 Hydraulic Seed).
- Typical hydraulic mulch application rates range from 2,000 pounds per acre for standard mulches (SMs) to 3,500 pounds per acre for BFMs. However, the required amount of hydraulic mulch to provide adequate coverage of exposed topsoil may appear to exceed the standard rates when the roughness of the soil surface is changed due to soil preparation methods (see EC-15 Soil Preparation) or by slope gradient.
- Other factors such as existing soil moisture and soil texture can have a profound effect on the amount of hydraulic mulch required (i.e. application rate) applied to achieve an erosion-resistant covering.
- Avoid use of mulch without a tackifier component, especially on slopes.
- Mulches used in the hydraulic mulch slurry can include:
 - Cellulose fiber
 - Thermally-processed wood fibers
 - Cotton
 - Synthetics
 - Compost (see EC-14, Compost Blanket)
- Additional guidance on the comparison and selection of temporary slope stabilization methods is provided in Appendix F of the Handbook.

Categories of Hydraulic Mulches

Standard Hydraulic Mulch (SM)

Standard hydraulic mulches are generally applied at a rate of 2,000 pounds per acre and are manufactured containing around 5% tackifier (i.e. soil binder), usually a plant-derived guar or psyllium type. Most standard mulches are green in color derived from food-color based dyes.

Hydraulic Matrices (HM) and Stabilized Fiber Matrices (SFM)

Hydraulic matrices and stabilized fiber matrices are slurries which contain increased levels of tackifiers/soil binders; usually 10% or more by weight. HMs and SFMs have improved performance compared to a standard hydraulic mulch (SM) because of the additional percentage of tackifier and because of their higher application rates, typically 2,500 – 4,000 pounds per acre. Hydraulic matrices can include a mixture of fibers, for example, a 50/50 blend of paper and wood fiber. In the case of an SFM, the tackifier/soil binder is specified as a polyacrylamide (PAM).

Bonded Fiber Matrix (BFM)

Bonded fiber matrices (BFMs) are hydraulically-applied systems of fibers, adhesives (typically guar based) and chemical cross-links. Upon drying, the slurry forms an erosion-resistant blanket that prevents soil erosion and promotes vegetation establishment. The cross-linked adhesive in the BFM should be biodegradable and should not dissolve or disperse upon re-wetting. BFMs are typically applied at rates from 3,000 to 4,000 lbs/acre based on the manufacturer’s recommendation. BFMs should not be applied immediately before, during or immediately after rainfall or if the soil is saturated. Depending on the product, BFMs typically require 12 to 24 hours to dry and become effective.

Mechanically-Bonded Fiber Matrices (MBFM)

Mechanically-bonded fiber matrices (MBFMs) are hydraulically applied systems similar to BFM that use crimped synthetic fibers and PAM and are typically applied to a slope at a higher application rate than a standard BFM.

Hydraulic Compost Matrix (HCM)

Hydraulic compost matrix (HCM) is a field-derived practice whereby finely graded or sifted compost is introduced into the hydraulic mulch slurry. A guar-type tackifier can be added for steeper slope applications as well as any specified seed mixtures. A HCM can help to accelerate seed germination and growth. HCMs are particularly useful as an in-fill for three-dimensional re-vegetation geocomposites, such as turf reinforcement mats (TRM) (see EC-7 Geotextiles and Mats).

Costs

Average installed costs for hydraulic mulch categories are provided in Table 1, below.

**Table 1
HYDRAULIC MULCH BMPs
INSTALLED COSTS**

BMP	Installed Cost/Acre
Standard Hydraulic Mulching (SM)	\$1,700 - \$3,600 per acre
Hydraulic Matrices (HM) and Stabilized Fiber Matrices	
Guar-based	\$2,000 - \$4,000 per acre
PAM-based	\$2,500 - \$5,610 per acre
Bonded Fiber Matrix (BFM)	\$3,900 - \$6,900 per acre
Mechanically Bonded Fiber Matrix (MBFM)	\$4,500 - \$6,000 per acre
Hydraulic Compost Matrix (HCM)	\$3,000 - \$3,500 per acre

Source: Cost information received from individual product manufacturers solicited by Geosyntec Consultants (2004)

Inspection and Maintenance

- Maintain an unbroken, temporary mulched ground cover throughout the period of construction when the soils are not being reworked.
- BMPs must be inspected in accordance with General Permit requirements for the associated project type and risk level. It is recommended that at a minimum, BMPs be inspected weekly, prior to forecasted rain events, daily during extended rain events, and after the conclusion of rain events.
- Areas where erosion is evident should be repaired and BMPs re-applied as soon as possible. Care should be exercised to minimize the damage to protected areas while making repairs, as any area damaged will require re-application of BMPs.
- Compare the number of bags or weight of applied mulch to the area treated to determine actual application rates and compliance with specifications.

References

Soil Stabilization BMP Research for Erosion and Sediment Controls: Cost Survey Technical Memorandum, State of California Department of Transportation (Caltrans), July 2007.

Controlling Erosion of Construction Sites, Agricultural Information #347, U.S. Department of Agriculture (USDA), Natural Resources Conservation Service (NRCS) (formerly Soil Conservation Service – SCS).

Guides for Erosion and Sediment Control in California, USDA Soils Conservation Service, January 1991.

Manual of Standards of Erosion and Sediment Control Measures, Association of Bay Area Governments, May 1995.

Sedimentation and Erosion Control, An Inventory of Current Practices Draft, US EPA, April 1990.

Soil Erosion by Water, Agriculture Information Bulletin #513, U.S. Department of Agriculture, Soil Conservation Service.

Stormwater Quality Handbooks Construction Site Best Management Practices (BMPs) Manual, State of California Department of Transportation (Caltrans), March 2003.

Guidance Document: Soil Stabilization for Temporary Slopes, State of California Department of Transportation (Caltrans), November 1999

Stormwater Management of the Puget Sound Basin, Technical Manual, Publication #91-75, Washington State Department of Ecology, February 1992.

Water Quality Management Plan for the Lake Tahoe Region, Volume II, Handbook of Management Practices, Tahoe Regional Planning Agency, November 1988.

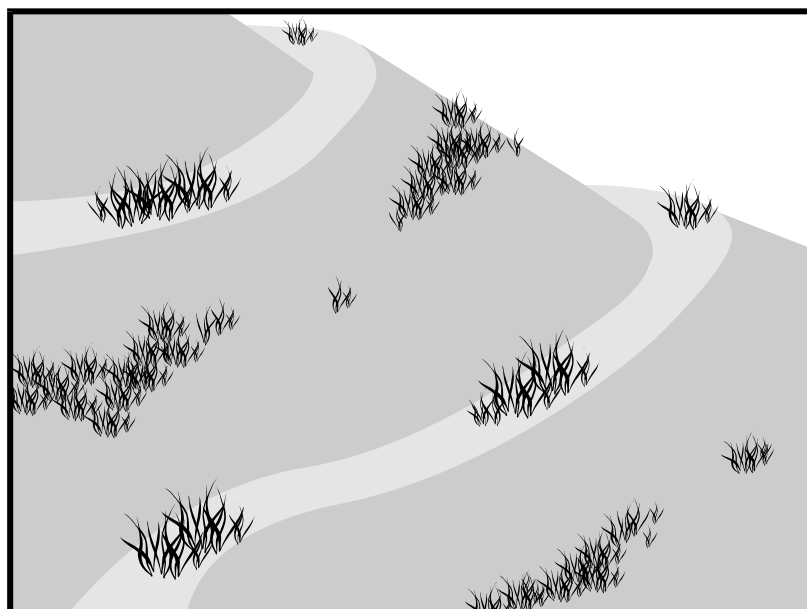

Description and Purpose

Hydroseeding typically consists of applying a mixture of a hydraulic mulch, seed, fertilizer, and stabilizing emulsion with a hydraulic mulcher, to temporarily protect exposed soils from erosion by water and wind. Hydraulic seeding, or hydroseeding, is simply the method by which temporary or permanent seed is applied to the soil surface.

Suitable Applications

Hydroseeding is suitable for disturbed areas requiring temporary protection until permanent stabilization is established, for disturbed areas that will be re-disturbed following an extended period of inactivity, or to apply permanent stabilization measures. Hydroseeding without mulch or other cover (e.g. EC-7, Erosion Control Blanket) is not a stand-alone erosion control BMP and should be combined with additional measures until vegetation establishment.

Typical applications for hydroseeding include:

- Disturbed soil/graded areas where permanent stabilization or continued earthwork is not anticipated prior to seed germination.
- Cleared and graded areas exposed to seasonal rains or temporary irrigation.
- Areas not subject to heavy wear by construction equipment or high traffic.

Categories

EC	Erosion Control	<input checked="" type="checkbox"/>
SE	Sediment Control	
TC	Tracking Control	
WE	Wind Erosion Control	<input checked="" type="checkbox"/>
NS	Non-Stormwater Management Control	
WM	Waste Management and Materials Pollution Control	

Legend:

- Primary Category
- Secondary Category

Targeted Constituents

Sediment	<input checked="" type="checkbox"/>
Nutrients	
Trash	
Metals	
Bacteria	
Oil and Grease	
Organics	

Potential Alternatives

- EC-3 Hydraulic Mulch
- EC-5 Soil Binders
- EC-6 Straw Mulch
- EC-7 Geotextiles and Mats
- EC-8 Wood Mulching
- EC-14 Compost Blanket
- EC-16 Non-Vegetative Stabilization

If User/Subscriber modifies this fact sheet in any way, the CASQA name/logo and footer below must be removed from each page and not appear on the modified version.



Limitations

- Availability of hydroseeding equipment may be limited just prior to the rainy season and prior to storms due to high demand.
- Hydraulic seed should be applied with hydraulic mulch or a stand-alone hydroseed application should be followed by one of the following:
 - Straw mulch (see Straw Mulch EC-6)
 - Rolled erosion control products (see Geotextiles and Mats EC-7)
 - Application of Compost Blanket (see Compost Blanket EC-14)

Hydraulic seed may be used alone only on small flat surfaces when there is sufficient time in the season to ensure adequate vegetation establishment and coverage to provide adequate erosion control.

- Hydraulic seed without mulch does not provide immediate erosion control.
- Temporary seeding may not be appropriate for steep slopes (i.e., slopes readily prone to rill erosion or without sufficient topsoil).
- Temporary seeding may not be appropriate in dry periods without supplemental irrigation.
- Temporary vegetation may have to be removed before permanent vegetation is applied.
- Temporary vegetation may not be appropriate for short term inactivity (i.e. less than 3-6 months).
- This BMP consists of a mixture of several constituents (e.g., fibers/mulches, tackifiers, and other chemical constituents), some of which may be proprietary and may come pre-mixed by the manufacturer. The water quality impacts of these constituents are relatively unknown and some may have water quality impacts due to their chemical makeup. Additionally these constituents may require non-visible pollutant monitoring. Refer to specific chemical properties identified in the product Material Safety Data Sheet; products should be evaluated for project-specific implementation by the SWPPP Preparer. Refer to factsheet EC-05 for further guidance on selecting soil binders.

Implementation

In order to select appropriate hydraulic seed mixtures, an evaluation of site conditions should be performed with respect to:

- Soil conditions
- Site topography and exposure (sun/wind)
- Season and climate
- Vegetation types
- Maintenance requirements
- Sensitive adjacent areas
- Water availability
- Plans for permanent vegetation

The local office of the U.S.D.A. Natural Resources Conservation Service (NRCS), Resource Conservation Districts and Agricultural Extension Service can provide information on appropriate seed mixes.

The following steps should be followed for implementation:

- Where appropriate or feasible, soil should be prepared to receive the seed by disking or otherwise scarifying (See EC-15, Soil Preparation) the surface to eliminate crust, improve air and water infiltration and create a more favorable environment for germination and growth.
- Avoid use of hydraulic seed in areas where the BMP would be incompatible with future earthwork activities.
- Hydraulic seed can be applied using a multiple step or one step process.
 - In a multiple step process, hydraulic seed is applied first, followed by mulch or a Rolled Erosion Control Product (RECP).
 - In the one step process, hydraulic seed is applied with hydraulic mulch in a hydraulic matrix. When the one step process is used to apply the mixture of fiber, seed, etc., the seed rate should be increased to compensate for all seeds not having direct contact with the soil.
- All hydraulically seeded areas should have mulch, or alternate erosion control cover to keep seeds in place and to moderate soil moisture and temperature until the seeds germinate and grow.
- All seeds should be in conformance with the California State Seed Law of the Department of Agriculture. Each seed bag should be delivered to the site sealed and clearly marked as to species, purity, percent germination, dealer's guarantee, and dates of test. The container should be labeled to clearly reflect the amount of Pure Live Seed (PLS) contained. All legume seed should be pellet inoculated. Inoculant sources should be species specific and should be applied at a rate of 2 lb of inoculant per 100 lb seed.
- Commercial fertilizer should conform to the requirements of the California Food and Agricultural Code, which can be found at http://www.leginfo.ca.gov/.html/fac_table_of_contents.html. Fertilizer should be pelleted or granular form.
- Follow up applications should be made as needed to cover areas of poor coverage or germination/vegetation establishment and to maintain adequate soil protection.
- Avoid over spray onto roads, sidewalks, drainage channels, existing vegetation, etc.
- Additional guidance on the comparison and selection of temporary slope stabilization methods is provided in Appendix F of the Handbook.

Costs

Average cost for installation and maintenance may vary from as low as \$1,900 per acre for flat slopes and stable soils, to \$4,000 per acre for moderate to steep slopes and/or erosive soils. Cost of seed mixtures vary based on types of required vegetation.

BMP	Installed Cost per Acre
Hydraulic Seed	\$1,900-\$4,000

Source: Cost information received from individual product manufacturers solicited by Geosyntec Consultants (2004).

Inspection and Maintenance

- BMPs must be inspected in accordance with General Permit requirements for the associated project type and risk level. It is recommended that at a minimum, BMPs be inspected weekly, prior to forecasted rain events, daily during extended rain events, and after the conclusion of rain events.
- Areas where erosion is evident should be repaired and BMPs re-applied as soon as possible. Care should be exercised to minimize the damage to protected areas while making repairs, as any area damaged will require re-application of BMPs.
- Where seeds fail to germinate, or they germinate and die, the area must be re-seeded, fertilized, and mulched within the planting season, using not less than half the original application rates.
- Irrigation systems, if applicable, should be inspected daily while in use to identify system malfunctions and line breaks. When line breaks are detected, the system must be shut down immediately and breaks repaired before the system is put back into operation.
- Irrigation systems should be inspected for complete coverage and adjusted as needed to maintain complete coverage.

References

Soil Stabilization BMP Research for Erosion and Sediment Controls: Cost Survey Technical Memorandum, State of California Department of Transportation (Caltrans), July 2007.

Stormwater Quality Handbooks Construction Site Best Management Practices (BMPs) Manual, State of California Department of Transportation (Caltrans), March 2003.

Guidance Document: Soil Stabilization for Temporary Slopes, State of California Department of Transportation (Caltrans), November 1999.

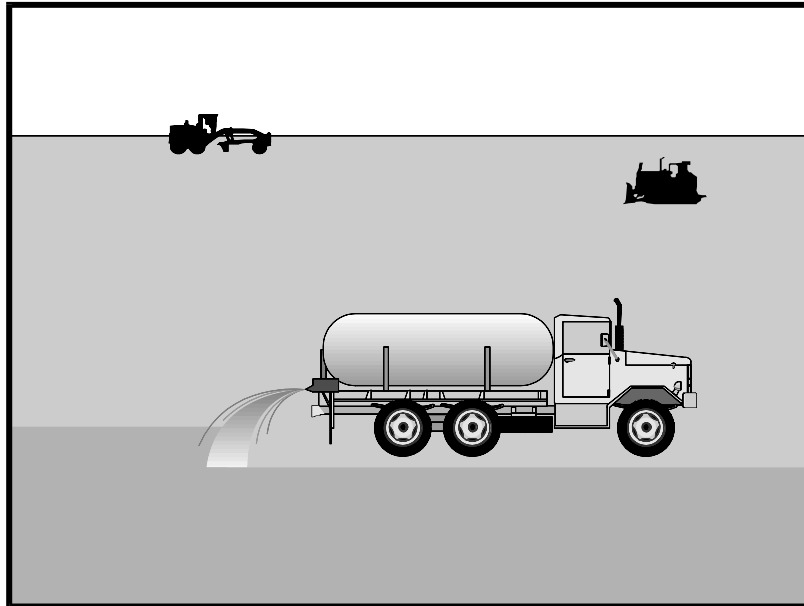

Description and Purpose

Soil binding consists of application and maintenance of a soil stabilizer to exposed soil surfaces. Soil binders are materials applied to the soil surface to temporarily prevent water and wind induced erosion of exposed soils on construction sites.

Suitable Applications

Soil binders are typically applied to disturbed areas requiring temporary protection. Because soil binders, when used as a stand-alone practice, can often be incorporated into the soil, they are a good alternative to mulches in areas where grading activities will soon resume. Soil binders are commonly used in the following areas:

- Rough graded soils that will be inactive for a short period of time
- Soil stockpiles
- Temporary haul roads prior to placement of crushed rock
- Compacted soil road base
- Construction staging, materials storage, and layout areas

Limitations

- Soil binders are temporary in nature and may need reapplication.
- Soil binders require a minimum curing time until fully effective, as prescribed by the manufacturer. Curing time

Categories

EC	Erosion Control	<input checked="" type="checkbox"/>
SE	Sediment Control	
TC	Tracking Control	
WE	Wind Erosion Control	<input checked="" type="checkbox"/>
NS	Non-Stormwater Management Control	
WM	Waste Management and Materials Pollution Control	

Legend:

- Primary Category
- Secondary Category

Targeted Constituents

Sediment	<input checked="" type="checkbox"/>
Nutrients	
Trash	
Metals	
Bacteria	
Oil and Grease	
Organics	

Potential Alternatives

- EC-3 Hydraulic Mulch
- EC-4 Hydroseeding
- EC-6 Straw Mulch
- EC-7 Geotextiles and Mats
- EC-8 Wood Mulching

If User/Subscriber modifies this fact sheet in any way, the CASQA name/logo and footer below must be removed from each page and not appear on the modified version.



may be 24 hours or longer. Soil binders may need reapplication after a storm event.

- Soil binders will generally experience spot failures during heavy rainfall events. If runoff penetrates the soil at the top of a slope treated with a soil binder, it is likely that the runoff will undercut the stabilized soil layer and discharge at a point further down slope.
- Plant-material-based soil binders do not generally hold up to pedestrian or vehicular traffic across treated areas as well as polymeric emulsion blends or cementitious-based binders.
- Soil binders may not sufficiently penetrate compacted soils.
- Some soil binders are soil texture specific in terms of their effectiveness. For example, polyacrylamides (PAMs) work very well on silt and clayey soils but their performance decreases dramatically in sandy soils.
- Some soil binders may not perform well with low relative humidity. Under rainy conditions, some agents may become slippery or leach out of the soil.
- Soil binders may not cure if low temperatures occur within 24 hours of application.
- The water quality impacts of some chemical soil binders are relatively unknown and some may have water quality impacts due to their chemical makeup. Additionally, these chemical may require non-visible pollutant monitoring. Products should be evaluated for project-specific implementation by the SWPPP Preparer. Refer to the product Material Safety Data Sheet for chemical properties.

Implementation

General Considerations

- Soil binders should conform to local municipality specifications and requirements.
- Site soil types will dictate appropriate soil binders to be used.
- A soil binder must be environmentally benign (non-toxic to plant and animal life), easy to apply, easy to maintain, economical, and should not stain paved or painted surfaces. Soil binders should not pollute stormwater when cured. Obtain a Material Safety Data Sheet (MSDS) from the manufacturer to ensure non-toxicity.
- Stormwater runoff from PAM treated soils should pass through one of the following sediment control BMP prior to discharging to surface waters.
 - When the total drainage area is greater than or equal to 5 acres, PAM treated areas should drain to a sediment basin.
 - Areas less than 5 acres should drain to sediment control BMPs, such as a sediment trap, or a series of check dams. The total number of check dams used should be maximized to achieve the greatest amount of settlement of sediment prior to discharging from the site. Each check dam should be spaced evenly in the drainage channel through which stormwater flows are discharged off site.

- Performance of soil binders depends on temperature, humidity, and traffic across treated areas.
- Avoid over spray onto roads, sidewalks, drainage channels, existing vegetation, etc.
- Additional guidance on the comparison and selection of temporary slope stabilization methods is provided in Appendix F of the Handbook.

Selecting a Soil Binder

Properties of common soil binders used for erosion control are provided on Table 1 at the end of this Fact Sheet. Use Table 1 to select an appropriate soil binder. Refer to WE-1, Wind Erosion Control, for dust control soil binders.

Factors to consider when selecting a soil binder include the following:

- Suitability to situation - Consider where the soil binder will be applied, if it needs a high resistance to leaching or abrasion, and whether it needs to be compatible with any existing vegetation. Determine the length of time soil stabilization will be needed, and if the soil binder will be placed in an area where it will degrade rapidly. In general, slope steepness is not a discriminating factor for the listed soil binders.
- Soil types and surface materials - Fines and moisture content are key properties of surface materials. Consider a soil binder's ability to penetrate, likelihood of leaching, and ability to form a surface crust on the surface materials.
- Frequency of application - The frequency of application is related to the functional longevity of the binder, which can be affected by subgrade conditions, surface type, climate, and maintenance schedule.
- Frequent applications could lead to high costs. Application frequency may be minimized if the soil binder has good penetration, low evaporation, and good longevity. Consider also that frequent application will require frequent equipment clean up.

Plant-Material-Based (Short Lived, <6 months) Binders

Guar: Guar is a non-toxic, biodegradable, natural galactomannan-based hydrocolloid treated with dispersant agents for easy field mixing. It should be mixed with water at the rate of 11 to 15 lb per 1,000 gallons. Recommended minimum application rates are as follows:

Application Rates for Guar Soil Stabilizer

Slope (H:V):	Flat	4:1	3:1	2:1	1:1
lb/acre:	40	45	50	60	70

Psyllium: Psyllium is composed of the finely ground muciloid coating of plantago seeds that is applied as a dry powder or in a wet slurry to the surface of the soil. It dries to form a firm but rewettable membrane that binds soil particles together, but permits germination and growth of seed. Psyllium requires 12 to 18 hours drying time. Application rates should be from 80 to 200 lb/acre, with enough water in solution to allow for a uniform slurry flow.

Starch: Starch is non-ionic, cold water soluble (pre-gelatinized) granular cornstarch. The material is mixed with water and applied at the rate of 150 lb/acre. Approximate drying time is 9 to 12 hours.

Plant-Material-Based (Long Lived, 6-12 months) Binders

Pitch and Rosin Emulsion: Generally, a non-ionic pitch and rosin emulsion has a minimum solids content of 48%. The rosin should be a minimum of 26% of the total solids content. The soil stabilizer should be non-corrosive, water dilutable emulsion that upon application cures to a water insoluble binding and cementing agent. For soil erosion control applications, the emulsion is diluted and should be applied as follows:

- For clayey soil: 5 parts water to 1 part emulsion
- For sandy soil: 10 parts water to 1 part emulsion

Application can be by water truck or hydraulic seeder with the emulsion and product mixture applied at the rate specified by the manufacturer.

Polymeric Emulsion Blend Binders

Acrylic Copolymers and Polymers: Polymeric soil stabilizers should consist of a liquid or solid polymer or copolymer with an acrylic base that contains a minimum of 55% solids. The polymeric compound should be handled and mixed in a manner that will not cause foaming or should contain an anti-foaming agent. The polymeric emulsion should not exceed its shelf life or expiration date; manufacturers should provide the expiration date. Polymeric soil stabilizer should be readily miscible in water, non-injurious to seed or animal life, non-flammable, should provide surface soil stabilization for various soil types without totally inhibiting water infiltration, and should not re-emulsify when cured. The applied compound typically requires 12 to 24 hours drying time. Liquid copolymer should be diluted at a rate of 10 parts water to 1 part polymer and the mixture applied to soil at a rate of 1,175 gallons/acre.

Liquid Polymers of Methacrylates and Acrylates: This material consists of a tackifier/sealer that is a liquid polymer of methacrylates and acrylates. It is an aqueous 100% acrylic emulsion blend of 40% solids by volume that is free from styrene, acetate, vinyl, ethoxylated surfactants or silicates. For soil stabilization applications, it is diluted with water in accordance with the manufacturer’s recommendations, and applied with a hydraulic seeder at the rate of 20 gallons/acre. Drying time is 12 to 18 hours after application.

Copolymers of Sodium Acrylates and Acrylamides: These materials are non-toxic, dry powders that are copolymers of sodium acrylate and acrylamide. They are mixed with water and applied to the soil surface for erosion control at rates that are determined by slope gradient:

Slope Gradient (H:V)	lb/acre
Flat to 5:1	3.0 – 5.0
5:1 to 3:1	5.0 – 10.0
2:1 to 1:1	10.0 – 20.0

Poly-Acrylamide (PAM) and Copolymer of Acrylamide: Linear copolymer polyacrylamide for use as a soil binder is packaged as a dry flowable solid, as a liquid. Refer to the manufacturer's recommendation for dilution and application rates as they vary based on liquid or dry form, site conditions and climate.

- Limitations specific to PAM are as follows:
 - Do not use PAM on a slope that flows into a water body without passing through a sediment trap or sediment basin.
 - The specific PAM copolymer formulation must be anionic. Cationic PAM should not be used in any application because of known aquatic toxicity problems. Only the highest drinking water grade PAM, certified for compliance with ANSI/NSF Standard 60 for drinking water treatment, should be used for soil applications.
 - PAM designated for erosion and sediment control should be "water soluble" or "linear" or "non-cross linked".
 - PAM should not be used as a stand-alone BMP to protect against water-based erosion. When combined with mulch, its effectiveness increases dramatically.

Hydro-Colloid Polymers: Hydro-Colloid Polymers are various combinations of dry flowable poly-acrylamides, copolymers and hydro-colloid polymers that are mixed with water and applied to the soil surface at rates of 55 to 60 lb/acre. Drying times are 0 to 4 hours.

Cementitious-Based Binders

Gypsum: This is a formulated gypsum based product that readily mixes with water and mulch to form a thin protective crust on the soil surface. It is composed of high purity gypsum that is ground, calcined and processed into calcium sulfate hemihydrate with a minimum purity of 86%. It is mixed in a hydraulic seeder and applied at rates 4,000 to 12,000 lb/acre. Drying time is 4 to 8 hours.

Applying Soil Binders

After selecting an appropriate soil binder, the untreated soil surface must be prepared before applying the soil binder. The untreated soil surface must contain sufficient moisture to assist the agent in achieving uniform distribution. In general, the following steps should be followed:

- Follow manufacturer's written recommendations for application rates, pre-wetting of application area, and cleaning of equipment after use.
- Prior to application, roughen embankment and fill areas.
- Consider the drying time for the selected soil binder and apply with sufficient time before anticipated rainfall. Soil binders should not be applied during or immediately before rainfall.
- Avoid over spray onto roads, sidewalks, drainage channels, sound walls, existing vegetation, etc.

- Soil binders should not be applied to frozen soil, areas with standing water, under freezing or rainy conditions, or when the temperature is below 40°F during the curing period.
- More than one treatment is often necessary, although the second treatment may be diluted or have a lower application rate.
- Generally, soil binders require a minimum curing time of 24 hours before they are fully effective. Refer to manufacturer's instructions for specific cure time.
- For liquid agents:
 - Crown or slope ground to avoid ponding.
 - Uniformly pre-wet ground at 0.03 to 0.3 gal/yd² or according to manufacturer's recommendations.
 - Apply solution under pressure. Overlap solution 6 to 12 in.
 - Allow treated area to cure for the time recommended by the manufacturer; typically at least 24 hours.
 - Apply second treatment before first treatment becomes ineffective, using 50% application rate.
 - In low humidities, reactivate chemicals by re-wetting with water at 0.1 to 0.2 gal/yd².

Costs

Costs vary according to the soil stabilizer selected for implementation. The following are approximate installed costs:

Soil Binder	Cost per Acre (2004) ¹	Estimated Cost per Acre (2009) ²
Plant-Material-Based (Short Lived) Binders	\$700-\$900	\$770-\$990
Plant-Material-Based (Long Lived) Binders	\$1,200-\$1,500	\$1,320-\$1,650
Polymeric Emulsion Blend Binders	\$700-\$1,500	\$770-\$1,650
Cementitious-Based Binders	\$800-\$1,200	\$880-\$1,350

1. Source: Cost information received from individual product manufacturers solicited by Geosyntec Consultants (2004).

2. 2009 costs reflect a 10% escalation over year 2004 costs. Escalation based on informal survey of industry trends. Note: Expected cost increase is offset by competitive economic conditions.

Inspection and Maintenance

- BMPs must be inspected in accordance with General Permit requirements for the associated project type and risk level. It is recommended that at a minimum, BMPs be inspected weekly, prior to forecasted rain events, daily during extended rain events, and after the conclusion of rain events.

- Areas where erosion is evident should be repaired and BMPs re-applied as soon as possible. Care should be exercised to minimize the damage to protected areas while making repairs, as any area damaged will require re-application of BMPs.
- Reapply the selected soil binder as needed to maintain effectiveness.

Evaluation Criteria	Binder Type			
	Plant Material Based (Short Lived)	Plant Material Based (Long Lived)	Polymeric Emulsion Blends	Cementitious-Based Binders
Relative Cost	Low	Moderate to High	Low to High	Low to Moderate
Resistance to Leaching	High	High	Low to Moderate	Moderate
Resistance to Abrasion	Moderate	Low	Moderate to High	Moderate to High
Longevity	Short to Medium	Medium	Medium to Long	Medium
Minimum Curing Time before Rain	9 to 18 hours	19 to 24 hours	0 to 24 hours	4 to 8 hours
Compatibility with Existing Vegetation	Good	Poor	Poor	Poor
Mode of Degradation	Biodegradable	Biodegradable	Photodegradable/ Chemically Degradable	Photodegradable/ Chemically Degradable
Labor Intensive	No	No	No	No
Specialized Application Equipment	Water Truck or Hydraulic Mulcher	Water Truck or Hydraulic Mulcher	Water Truck or Hydraulic Mulcher	Water Truck or Hydraulic Mulcher
Liquid/Powder	Powder	Liquid	Liquid/Powder	Powder
Surface Crusting	Yes, but dissolves on rewetting	Yes	Yes, but dissolves on rewetting	Yes
Clean Up	Water	Water	Water	Water
Erosion Control Application Rate	Varies ⁽¹⁾	Varies ⁽¹⁾	Varies ⁽¹⁾	4,000 to 12,000 lbs/acre

(1) See Implementation for specific rates.

References

Erosion Control Pilot Study Report, State of California Department of Transportation (Caltrans), June 2000.

Manual of Standards of Erosion and Sediment Control Measures, Association of Bay Area Governments, May 1995.

Sedimentation and Erosion Control, An Inventory of Current Practices Draft, US EPA, April 1990.

Stormwater Quality Handbooks Construction Site Best Management Practices (BMPs) Manual, State of California Department of Transportation (Caltrans), March 2003.

Guidance Document: Soil Stabilization for Temporary Slopes, State of California Department of Transportation (Caltrans), November 1999.

Stormwater Management for Construction Activities, Developing Pollution Prevention Plans and Best Management Practices, EPA 832-R-92005; USEPA, April 1992.

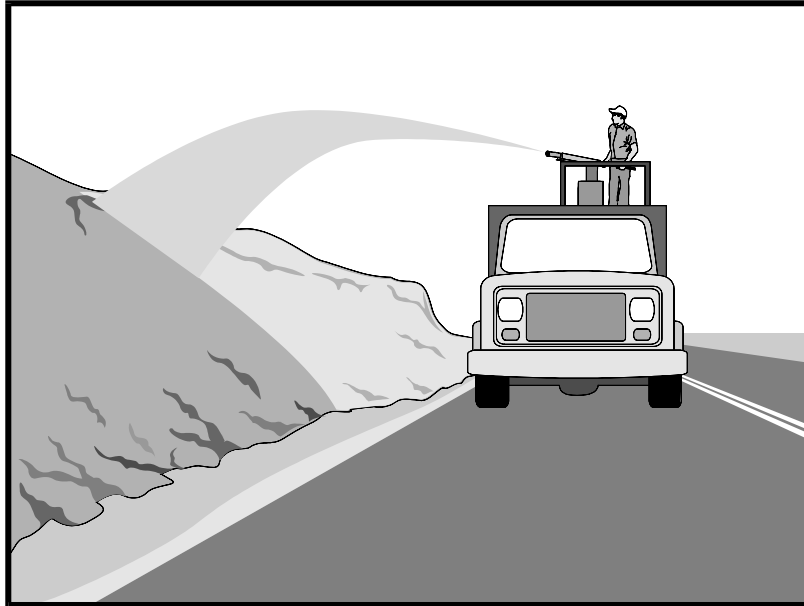

Description and Purpose

Straw mulch consists of placing a uniform layer of straw and incorporating it into the soil with a studded roller or crimper, or anchoring it with a tackifier or stabilizing emulsion. Straw mulch protects the soil surface from the impact of rain drops, preventing soil particles from becoming dislodged.

Suitable Applications

Straw mulch is suitable for disturbed areas requiring temporary protection until permanent stabilization is established. Straw mulch can be specified for the following applications:

- As a stand-alone BMP on disturbed areas until soils can be prepared for permanent vegetation. The longevity of straw mulch is typically less than six months.
- Applied in combination with temporary seeding strategies
- Applied in combination with permanent seeding strategies to enhance plant establishment and final soil stabilization
- Applied around containerized plantings to control erosion until the plants become established to provide permanent stabilization

Limitations

Availability of straw and straw blowing equipment may be limited just prior to the rainy season and prior to storms due to high demand.

Categories

EC	Erosion Control	<input checked="" type="checkbox"/>
SE	Sediment Control	<input type="checkbox"/>
TC	Tracking Control	<input type="checkbox"/>
WE	Wind Erosion Control	<input checked="" type="checkbox"/>
NS	Non-Stormwater Management Control	<input type="checkbox"/>
WM	Waste Management and Materials Pollution Control	<input type="checkbox"/>

Legend:

- Primary Category
- Secondary Category

Targeted Constituents

Sediment	<input checked="" type="checkbox"/>
Nutrients	<input type="checkbox"/>
Trash	<input type="checkbox"/>
Metals	<input type="checkbox"/>
Bacteria	<input type="checkbox"/>
Oil and Grease	<input type="checkbox"/>
Organics	<input type="checkbox"/>

Potential Alternatives

- EC-3 Hydraulic Mulch
- EC-4 Hydroseeding
- EC-5 Soil Binders
- EC-7 Geotextiles and Mats
- EC-8 Wood Mulching
- EC-14 Compost Blanket

If User/Subscriber modifies this fact sheet in any way, the CASQA name/logo and footer below must be removed from each page and not appear on the modified version.



- There is a potential for introduction of weed seed and unwanted plant material if weed-free agricultural straw is not specified.
- Straw mulch applied by hand is more time intensive and potentially costly.
- Wind may limit application of straw and blow straw into undesired locations.
- May have to be removed prior to permanent seeding or prior to further earthwork.
- “Punching” of straw does not work in sandy soils, necessitating the use of tackifiers.
- Potential fugitive dust control issues associated with straw applications can occur. Application of a stabilizing emulsion or a water stream at the same time straw is being blown can reduce this problem.
- Use of plastic netting should be avoided in areas where wildlife may be entrapped and may be prohibited for projects in certain areas with sensitive wildlife species, especially reptiles and amphibians.

Implementation

- Straw should be derived from weed-free wheat, rice, or barley. Where required by the plans, specifications, permits, or environmental documents, native grass straw should be used.
- Use tackifier to anchor straw mulch to the soil on slopes.
- Crimping, punch roller-type rollers, or track walking may also be used to incorporate straw mulch into the soil on slopes. Track walking can be used where other methods are impractical.
- Avoid placing straw onto roads, sidewalks, drainage channels, sound walls, existing vegetation, etc.
- Straw mulch with tackifier should not be applied during or immediately before rainfall.
- Additional guidance on the comparison and selection of temporary slope stabilization methods is provided in Appendix F of the Handbook.

Application Procedures

- When using a tackifier to anchor the straw mulch, roughen embankment or fill areas by rolling with a crimping or punching-type roller or by track walking before placing the straw mulch. Track walking should only be used where rolling is impractical.
- Apply straw at a rate of between 3,000 and 4,000 lb/acre, either by machine or by hand distribution and provide 100% ground cover. A lighter application is used for flat surfaces and a heavier application is used for slopes.
- Evenly distribute straw mulch on the soil surface.
- Anchoring straw mulch to the soil surface by "punching" it into the soil mechanically (incorporating) can be used in lieu of a tackifier.

- Methods for holding the straw mulch in place depend upon the slope steepness, accessibility, soil conditions, and longevity.
 - A tackifier acts to glue the straw fibers together and to the soil surface. The tackifier should be selected based on longevity and ability to hold the fibers in place. A tackifier is typically applied at a rate of 125 lb/acre. In windy conditions, the rates are typically 180 lb/acre.
 - On very small areas, a spade or shovel can be used to punch in straw mulch.
 - On slopes with soils that are stable enough and of sufficient gradient to safely support construction equipment without contributing to compaction and instability problems, straw can be "punched" into the ground using a knife blade roller or a straight bladed coultter, known commercially as a "crimper."

Costs

Average annual cost for installation and maintenance is included in the table below. Application by hand is more time intensive and potentially more costly.

BMP	Unit Cost per Acre
Straw mulch, crimped or punched	\$2,458-\$5,375
Straw mulch with tackifier	\$1,823-\$4,802

Source: Cost information received from individual product suppliers solicited by Geosyntec Consultants (2004).

Inspection and Maintenance

- BMPs must be inspected in accordance with General Permit requirements for the associated project type and risk level. It is recommended that at a minimum, BMPs be inspected weekly, prior to forecasted rain events, daily during extended rain events, and after the conclusion of rain events.
- Areas where erosion is evident should be repaired and BMPs re-applied as soon as possible. Care should be exercised to minimize the damage to protected areas while making repairs, as any area damaged will require re-application of BMPs.
- The key consideration in inspection and maintenance is that the straw needs to last long enough to achieve erosion control objectives. Straw mulch as a stand-alone BMP is temporary and is not suited for long-term erosion control.
- Maintain an unbroken, temporary mulched ground cover while disturbed soil areas are inactive. Repair any damaged ground cover and re-mulch exposed areas.
- Reapplication of straw mulch and tackifier may be required to maintain effective soil stabilization over disturbed areas and slopes.

References

Soil Stabilization BMP Research for Erosion and Sediment Controls: Cost Survey Technical Memorandum, State of California Department of Transportation (Caltrans), July 2007.

Erosion and Sediment Control Manual, Oregon Department of Environmental Quality, February 2005.

Controlling Erosion of Construction Sites, Agricultural Information Bulletin #347, U.S. Department of Agriculture (USDA), Natural Resources Conservation Service (NRCS) (formerly Soil Conservation Service – SCS).

Guides for Erosion and Sediment Control in California, USDA Soils Conservation Service, January 1991.

Manual of Standards of Erosion and Sediment Control Measures, Association of Bay Area Governments, May 1995.

Soil Erosion by Water, Agricultural Information Bulletin #513, U.S. Department of Agriculture, Soil Conservation Service.

Stormwater Quality Handbooks Construction Site Best Management Practices (BMPs) Manual, State of California Department of Transportation (Caltrans), March 2003.

Stormwater Management of the Puget Sound Basin, Technical Manual, Publication #91-75, Washington State Department of Ecology, February 1992.

Water Quality Management Plan for the Lake Tahoe Region, Volume II, Handbook of Management Practices, Tahoe Regional Planning Agency, November 1988.

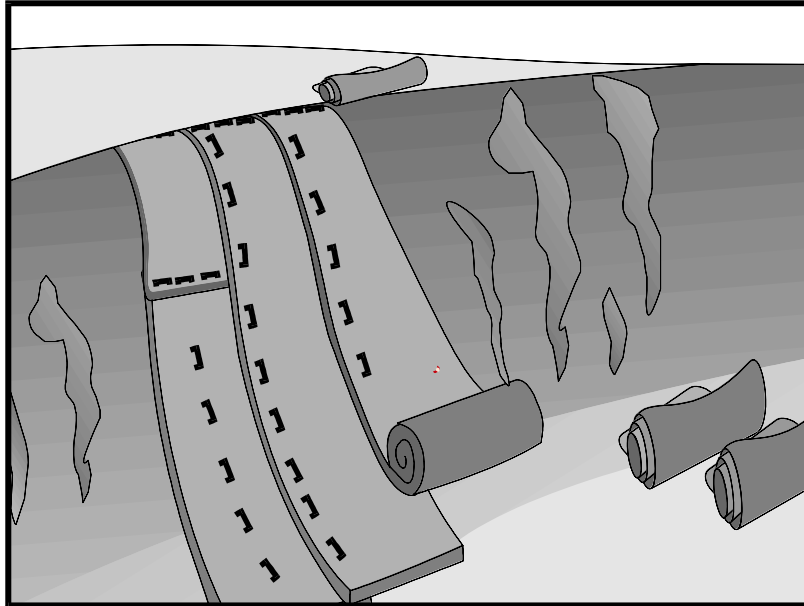

Description and Purpose

Mattings, or Rolled Erosion Control Products (RECPs), can be made of natural or synthetic materials or a combination of the two. RECPs are used to cover the soil surface to reduce erosion from rainfall impact, hold soil in place, and absorb and hold moisture near the soil surface. Additionally, RECPs may be used to stabilize soils until vegetation is established or to reinforce non-woody surface vegetation.

Suitable Applications

RECPs are typically applied on slopes where erosion hazard is high and vegetation will be slow to establish. Mattings are also used on stream banks, swales and other drainage channels where moving water at velocities between 3 ft/s and 6 ft/s are likely to cause scour and wash out new vegetation, and in areas where the soil surface is disturbed and where existing vegetation has been removed. RECPs may also be used when seeding cannot occur (e.g., late season construction and/or the arrival of an early rain season). RECPs should be considered when the soils are fine grained and potentially erosive. RECPs should be considered in the following situations.

- Steep slopes, generally steeper than 3:1 (H:V)
- Slopes where the erosion potential is high
- Slopes and disturbed soils where mulch must be anchored
- Disturbed areas where plants are slow to develop

Categories

EC	Erosion Control	<input checked="" type="checkbox"/>
SE	Sediment Control	
TC	Tracking Control	
WE	Wind Erosion Control	<input checked="" type="checkbox"/>
NS	Non-Stormwater Management Control	
WM	Waste Management and Materials Pollution Control	

Legend:

- Primary Category
- Secondary Category

Targeted Constituents

Sediment	<input checked="" type="checkbox"/>
Nutrients	
Trash	
Metals	
Bacteria	
Oil and Grease	
Organics	

Potential Alternatives

- EC-3 Hydraulic Mulch
- EC-4 Hydroseeding

If User/Subscriber modifies this fact sheet in any way, the CASQA name/logo and footer below must be removed from each page and not appear on the modified version.



- Channels with flows exceeding 3.3 ft/s
- Channels to be vegetated
- Stockpiles
- Slopes adjacent to water bodies

Limitations

- RECP installed costs are generally higher than other erosion control BMPs, limiting their use to areas where other BMPs are ineffective (e.g. channels, steep slopes).
- RECPs may delay seed germination, due to reduction in soil temperature.
- RECPs are generally not suitable for excessively rocky sites or areas where the final vegetation will be mowed (since staples and netting can catch in mowers). If a staple or pin cannot be driven into the soil because the underlying soil is too hard or rocky, then an alternative BMP should be selected.
- If used for temporary erosion control, RECPs should be removed and disposed of prior to application of permanent soil stabilization measures.
- The use of plastic should be limited to covering stockpiles or very small graded areas for short periods of time (such as through one imminent storm event) until more environmentally friendly measures, such as seeding and mulching, may be installed.
 - Plastic sheeting is easily vandalized, easily torn, photodegradable, and must be disposed of at a landfill.
 - Plastic sheeting results in 100% runoff, which may cause serious erosion problems in the areas receiving the increased flow.
- RECPs may have limitations based on soil type, slope gradient, or channel flow rate; consult the manufacturer for proper selection.
- Not suitable for areas that have foot traffic (tripping hazard) – e.g., pad areas around buildings under construction.
- RECPs that incorporate a plastic netting (e.g. straw blanket typically uses a plastic netting to hold the straw in place) may not be suitable near known wildlife habitat. Wildlife can become trapped in the plastic netting.
- RECPs may have limitations in extremely windy climates. However, when RECPs are properly trenched at the top and bottom and stapled in accordance with the manufacturer's recommendations, problems with wind can be minimized.

Implementation

Material Selection

- Natural RECPs have been found to be effective where re-vegetation will be provided by re-seeding. The choice of material should be based on the size of area, side slopes, surface conditions such as hardness, moisture, weed growth, and availability of materials.
- Additional guidance on the comparison and selection of temporary slope stabilization methods is provided in Appendix F of the Handbook.
- The following natural and synthetic RECPs are commonly used:

Geotextiles

- Material can be a woven or a non-woven polypropylene fabric with minimum thickness of 0.06 in., minimum width of 12 ft and should have minimum tensile strength of 150 lbs (warp), 80 lbs (fill) in conformance with the requirements in ASTM Designation: D 4632. The permittivity of the fabric should be approximately 0.07 sec^{-1} in conformance with the requirements in ASTM Designation: D4491. The fabric should have an ultraviolet (UV) stability of 70 percent in conformance with the requirements in ASTM designation: D4355. Geotextile blankets must be secured in place with wire staples or sandbags and by keying into tops of slopes to prevent infiltration of surface waters under geotextile. Staples should be made of minimum 11 gauge steel wire and should be U-shaped with 8 in. legs and 2 in. crown.
- Geotextiles may be reused if they are suitable for the use intended.

Plastic Covers

- Generally plastic sheeting should only be used as stockpile covering or for very small graded areas for short periods of time (such as through one imminent storm event). If plastic sheeting must be used, choose a plastic that will withstand photo degradation.
- Plastic sheeting should have a minimum thickness of 6 mils, and must be keyed in at the top of slope (when used as a temporary slope protection) and firmly held in place with sandbags or other weights placed no more than 10 ft apart. Seams are typically taped or weighted down their entire length, and there should be at least a 12 in. to 24 in. overlap of all seams. Edges should be embedded a minimum of 6 in. in soil (when used as a temporary slope protection).
- All sheeting must be inspected periodically after installation and after significant rainstorms to check for erosion, undermining, and anchorage failure. Any failures must be repaired immediately. If washout or breakages occur, the material should be re-installed after repairing the damage to the slope.

Erosion Control Blankets/Mats

- Biodegradable RECPs are typically composed of jute fibers, curled wood fibers, straw, coconut fiber, or a combination of these materials. In order for an RECP to be considered 100% biodegradable, the netting, sewing or adhesive system that holds the biodegradable mulch fibers together must also be biodegradable. See typical installation details at the end of this fact sheet.

- **Jute** is a natural fiber that is made into a yarn that is loosely woven into a biodegradable mesh. The performance of jute as a stand-alone RECP is low. Most other RECPs outperform jute as a temporary erosion control product and therefore jute is not commonly used. It is designed to be used in conjunction with vegetation. The material is supplied in rolled strips, which should be secured to the soil with U-shaped staples or stakes in accordance with manufacturers' recommendations.
- **Excelsior** (curled wood fiber) blanket material should consist of machine produced mats of curled wood excelsior with 80 percent of the fiber 6 in. or longer. The excelsior blanket should be of consistent thickness. The wood fiber must be evenly distributed over the entire area of the blanket. The top surface of the blanket should be covered with a photodegradable extruded plastic mesh. The blanket should be smolder resistant without the use of chemical additives and should be non-toxic and non-injurious to plant and animal life. Excelsior blankets should be furnished in rolled strips, a minimum of 48 in. wide, and should have an average weight of 0.8 lb/yd², ±10 percent, at the time of manufacture. Excelsior blankets must be secured in place with wire staples. Staples should be made of minimum 11 gauge steel wire and should be U-shaped with 8 in. legs and 2 in. crown.
- **Straw blanket** should be machine produced mats of straw with a lightweight biodegradable netting top layer. The straw should be attached to the netting with biodegradable thread or glue strips. The straw blanket should be of consistent thickness. The straw should be evenly distributed over the entire area of the blanket. Straw blanket should be furnished in rolled strips a minimum of 6.5 ft wide, a minimum of 80 ft long and a minimum of 0.5 lb/yd². Straw blankets must be secured in place with wire staples. Staples should be made of minimum 11 gauge steel wire and should be U-shaped with 8 in. legs and 2 in. crown.
- **Wood fiber blanket** is composed of biodegradable fiber mulch with extruded plastic netting held together with adhesives. The material is designed to enhance re-vegetation. The material is furnished in rolled strips, which must be secured to the ground with U-shaped staples or stakes in accordance with manufacturers' recommendations.
- **Coconut fiber blanket** should be a machine produced mat of 100 percent coconut fiber with biodegradable netting on the top and bottom. The coconut fiber should be attached to the netting with biodegradable thread or glue strips. The coconut fiber blanket should be of consistent thickness. The coconut fiber should be evenly distributed over the entire area of the blanket. Coconut fiber blanket should be furnished in rolled strips with a minimum of 6.5 ft wide, a minimum of 80 ft. long and a minimum of 0.5 lb/yd². Coconut fiber blankets must be secured in place with wire staples. Staples should be made of minimum 11 gauge steel wire and should be U-shaped with 8 in. legs and 2 in. crown.
- **Coconut fiber mesh** is a thin permeable membrane made from coconut or corn fiber that is spun into a yarn and woven into a biodegradable mat. It is designed to be used in conjunction with vegetation and typically has longevity of several years. The material is supplied in rolled strips, which must be secured to the soil with U-shaped staples or stakes in accordance with manufacturers' recommendations.

- **Straw coconut fiber blanket** should be machine produced mats of 70 percent straw and 30 percent coconut fiber with a biodegradable netting top layer and a biodegradable bottom net. The straw and coconut fiber should be attached to the netting with biodegradable thread or glue strips. The straw coconut fiber blanket should be of consistent thickness. The straw and coconut fiber should be evenly distributed over the entire area of the blanket. Straw coconut fiber blanket should be furnished in rolled strips a minimum of 6.5 ft wide, a minimum of 80 ft long and a minimum of 0.5 lb/yd². Straw coconut fiber blankets must be secured in place with wire staples. Staples should be made of minimum 11 gauge steel wire and should be U-shaped with 8 in. legs and 2 in. crown.
- Non-biodegradable RECPs are typically composed of polypropylene, polyethylene, nylon or other synthetic fibers. In some cases, a combination of biodegradable and synthetic fibers is used to construct the RECP. Netting used to hold these fibers together is typically non-biodegradable as well.
 - **Plastic netting** is a lightweight biaxially oriented netting designed for securing loose mulches like straw or paper to soil surfaces to establish vegetation. The netting is photodegradable. The netting is supplied in rolled strips, which must be secured with U-shaped staples or stakes in accordance with manufacturers' recommendations.
 - **Plastic mesh** is an open weave geotextile that is composed of an extruded synthetic fiber woven into a mesh with an opening size of less than 1/4 in. It is used with re-vegetation or may be used to secure loose fiber such as straw to the ground. The material is supplied in rolled strips, which must be secured to the soil with U-shaped staples or stakes in accordance with manufacturers' recommendations.
 - **Synthetic fiber with netting** is a mat that is composed of durable synthetic fibers treated to resist chemicals and ultraviolet light. The mat is a dense, three dimensional mesh of synthetic (typically polyolefin) fibers stitched between two polypropylene nets. The mats are designed to be re-vegetated and provide a permanent composite system of soil, roots, and geomatrix. The material is furnished in rolled strips, which must be secured with U-shaped staples or stakes in accordance with manufacturers' recommendations.
 - **Bonded synthetic fibers** consist of a three dimensional geomatrix nylon (or other synthetic) matting. Typically it has more than 90 percent open area, which facilitates root growth. It's tough root reinforcing system anchors vegetation and protects against hydraulic lift and shear forces created by high volume discharges. It can be installed over prepared soil, followed by seeding into the mat. Once vegetated, it becomes an invisible composite system of soil, roots, and geomatrix. The material is furnished in rolled strips that must be secured with U-shaped staples or stakes in accordance with manufacturers' recommendations.
 - **Combination synthetic and biodegradable RECPs** consist of biodegradable fibers, such as wood fiber or coconut fiber, with a heavy polypropylene net stitched to the top and a high strength continuous filament geomatrix or net stitched to the bottom. The material is designed to enhance re-vegetation. The material is furnished in rolled strips,

which must be secured with U-shaped staples or stakes in accordance with manufacturers' recommendations.

Site Preparation

- Proper soil preparation is essential to ensure complete contact of the RECP with the soil. Soil Roughening is not recommended in areas where RECPs will be installed.
- Grade and shape the area of installation.
- Remove all rocks, clods, vegetation or other obstructions so that the installed blankets or mats will have complete, direct contact with the soil.
- Prepare seedbed by loosening 2 to 3 in. of topsoil.

Seeding/Planting

Seed the area before blanket installation for erosion control and re-vegetation. Seeding after mat installation is often specified for turf reinforcement application. When seeding prior to blanket installation, all areas disturbed during blanket installation must be re-seeded. Where soil filling is specified for turf reinforcement mats (TRMs), seed the matting and the entire disturbed area after installation and prior to filling the mat with soil.

Fertilize and seed in accordance with seeding specifications or other types of landscaping plans. The protective matting can be laid over areas where grass has been planted and the seedlings have emerged. Where vines or other ground covers are to be planted, lay the protective matting first and then plant through matting according to design of planting.

Check Slots

Check slots shall be installed as required by the manufacturer.

Laying and Securing Matting

- Before laying the matting, all check slots should be installed and the seedbed should be friable, made free from clods, rocks, and roots. The surface should be compacted and finished according to the requirements of the manufacturer's recommendations.
- Mechanical or manual lay down equipment should be capable of handling full rolls of fabric and laying the fabric smoothly without wrinkles or folds. The equipment should meet the fabric manufacturer's recommendations or equivalent standards.

Anchoring

- U-shaped wire staples, metal geotextile stake pins, or triangular wooden stakes can be used to anchor mats and blankets to the ground surface.
- Wire staples should be made of minimum 11 gauge steel wire and should be U-shaped with 8 in. legs and 2 in. crown.
- Metal stake pins should be 0.188 in. diameter steel with a 1.5 in. steel washer at the head of the pin, and 8 in. in length.
- Wire staples and metal stakes should be driven flush to the soil surface.

Installation on Slopes

Installation should be in accordance with the manufacturer's recommendations. In general, these will be as follows:

- Begin at the top of the slope and anchor the blanket in a 6 in. deep by 6 in. wide trench. Backfill trench and tamp earth firmly.
- Unroll blanket down slope in the direction of water flow.
- Overlap the edges of adjacent parallel rolls 2 to 3 in. and staple every 3 ft (or greater, per manufacturer's specifications).
- When blankets must be spliced, place blankets end over end (shingle style) with 6 in. overlap. Staple through overlapped area, approximately 12 in. apart.
- Lay blankets loosely and maintain direct contact with the soil. Do not stretch.
- Staple blankets sufficiently to anchor blanket and maintain contact with the soil. Staples should be placed down the center and staggered with the staples placed along the edges. Steep slopes, 1:1 (H:V) to 2:1 (H:V), require a minimum of 2 staples/yd². Moderate slopes, 2:1 (H:V) to 3:1 (H:V), require a minimum of 1 1/2 staples/yd². Check manufacturer's specifications to determine if a higher density staple pattern is required.

Installation in Channels

Installation should be in accordance with the manufacturer's recommendations. In general, these will be as follows:

- Dig initial anchor trench 12 in. deep and 6 in. wide across the channel at the lower end of the project area.
- Excavate intermittent check slots, 6 in. deep and 6 in. wide across the channel at 25 to 30 ft intervals along the channels.
- Cut longitudinal channel anchor trenches 4 in. deep and 4 in. wide along each side of the installation to bury edges of matting, whenever possible extend matting 2 to 3 in. above the crest of the channel side slopes.
- Beginning at the downstream end and in the center of the channel, place the initial end of the first roll in the anchor trench and secure with fastening devices at 12 in. intervals. Note: matting will initially be upside down in anchor trench.
- In the same manner, position adjacent rolls in anchor trench, overlapping the preceding roll a minimum of 3 in.
- Secure these initial ends of mats with anchors at 12 in. intervals, backfill and compact soil.
- Unroll center strip of matting upstream. Stop at next check slot or terminal anchor trench. Unroll adjacent mats upstream in similar fashion, maintaining a 3 in. overlap.

- Fold and secure all rolls of matting snugly into all transverse check slots. Lay mat in the bottom of the slot then fold back against itself. Anchor through both layers of mat at 12 in. intervals, then backfill and compact soil. Continue rolling all mat widths upstream to the next check slot or terminal anchor trench.
- Alternate method for non-critical installations: Place two rows of anchors on 6 in. centers at 25 to 30 ft. intervals in lieu of excavated check slots.
- Staple shingled lap spliced ends a minimum of 12 in. apart on 12 in. intervals.
- Place edges of outside mats in previously excavated longitudinal slots; anchor using prescribed staple pattern, backfill, and compact soil.
- Anchor, fill, and compact upstream end of mat in a 12 in. by 6 in. terminal trench.
- Secure mat to ground surface using U-shaped wire staples, geotextile pins, or wooden stakes.
- Seed and fill turf reinforcement matting with soil, if specified.

Soil Filling (if specified for turf reinforcement mat (TRM))

Installation should be in accordance with the manufacturer's recommendations. Typical installation guidelines are as follows:

- After seeding, spread and lightly rake 1/2-3/4 inches of fine topsoil into the TRM apertures to completely fill TRM thickness. Use backside of rake or other flat implement.
- Alternatively, if allowed by product specifications, spread topsoil using lightweight loader, backhoe, or other power equipment. Avoid sharp turns with equipment.
- Always consult the manufacturer's recommendations for installation.
- Do not drive tracked or heavy equipment over mat.
- Avoid any traffic over matting if loose or wet soil conditions exist.
- Use shovels, rakes, or brooms for fine grading and touch up.
- Smooth out soil filling just exposing top netting of mat.

Temporary Soil Stabilization Removal

- Temporary soil stabilization removed from the site of the work must be disposed of if necessary.

Costs

Installed costs can be relatively high compared to other BMPs. Approximate costs for installed materials are shown below:

Rolled Erosion Control Products		Installed Cost per Acre (2004) ¹	Estimated Cost per Acre (2009) ²
Biodegradable	Jute Mesh	\$6,000-\$7,000	\$6,600-\$7,700
	Curled Wood Fiber	\$8,000-\$10,500	\$8,800-\$11,050
	Straw	\$8,000-\$10,500	\$8,800-\$11,050
	Wood Fiber	\$8,000-\$10,500	\$8,800-\$11,050
	Coconut Fiber	\$13,000-\$14,000	\$14,300-\$15,400
	Coconut Fiber Mesh	\$30,000-\$33,000	\$33,000-\$36,300
	Straw Coconut Fiber	\$10,000-\$12,000	\$11,000-\$13,200
Non-Biodegradable	Plastic Netting	\$2,000-\$2,200	\$2,200-\$2,220
	Plastic Mesh	\$3,000-\$3,500	\$3,300-\$3,850
	Synthetic Fiber with Netting	\$34,000-\$40,000	\$37,400-\$44,000
	Bonded Synthetic Fibers	\$45,000-\$55,000	\$49,500-\$60,500
	Combination with Biodegradable	\$30,000-\$36,000	\$33,000-\$39,600

1. Source: Cost information received from individual product manufacturers solicited by Geosyntec Consultants (2004).
2. 2009 costs reflect a 10% escalation over year 2004 costs. Escalation based on informal survey of industry trends. Note: Expected cost increase is offset by competitive economic conditions.

Inspection and Maintenance

- RECPs must be inspected in accordance with General Permit requirements for the associated project type and risk level. It is recommended that at a minimum, BMPs be inspected weekly, prior to forecasted rain events, daily during extended rain events, and after the conclusion of rain events.
- Areas where erosion is evident shall be repaired and BMPs reapplied as soon as possible. Care should be exercised to minimize the damage to protected areas while making repairs, as any area damaged will require reapplication of BMPs.
- If washout or breakage occurs, re-install the material after repairing the damage to the slope or channel.
- Make sure matting is uniformly in contact with the soil.
- Check that all the lap joints are secure.
- Check that staples are flush with the ground.

References

Erosion and Sediment Control Manual, Oregon Department of Environmental Quality, February 2005

Erosion Control Pilot Study Report, State of California Department of Transportation (Caltrans), June 2000.

Guides for Erosion and Sediment Controls in California, USDA Soils Conservation Service, January 1991.

National Management Measures to Control Nonpoint Source Pollution from Urban Areas, United States Environmental Protection Agency, 2002.

Stormwater Quality Handbooks Construction Site Best Management Practices (BMPs) Manual, State of California Department of Transportation (Caltrans), March 2003.

Guidance Document: Soil Stabilization for Temporary Slopes, State of California Department of Transportation (Caltrans), November 1999.

Stormwater Management of the Puget Sound Basin, Technical Manual, Publication #91-75, Washington State Department of Ecology, February 1992.

Water Quality Management Plan for The Lake Tahoe Region, Volume II, Handbook of Management Practices, Tahoe Regional Planning Agency, November 1988.

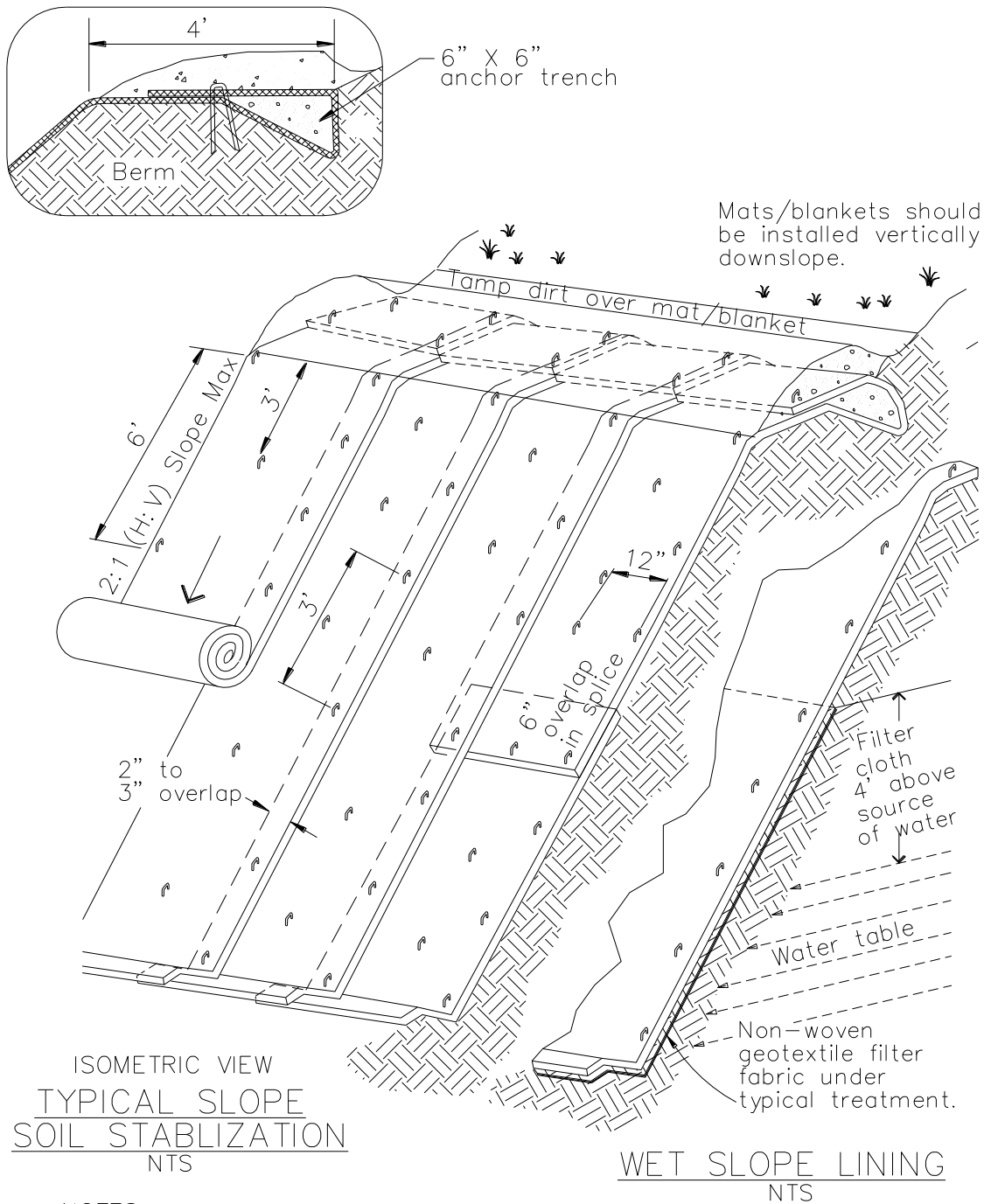

NOTES:

1. Slope surface shall be free of rocks, clods, sticks and grass. Mats/blankets shall have good soil contact.
2. Lay blankets loosely and stake or staple to maintain direct contact with the soil. Do not stretch.
3. Install per manufacturer's recommendations

TYPICAL INSTALLATION DETAIL

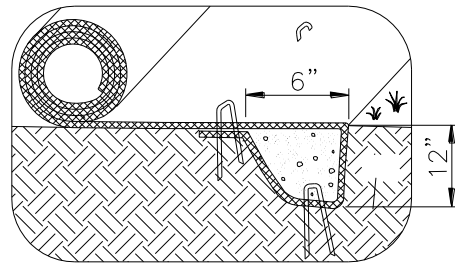

INITIAL CHANNEL ANCHOR TRENCH
NTS

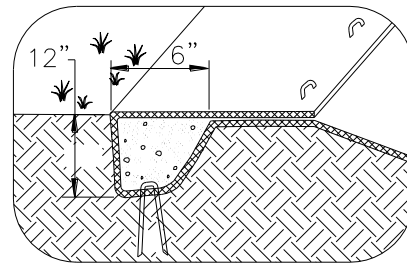

TERMINAL SLOPE AND CHANNEL ANCHOR TRENCH
NTS

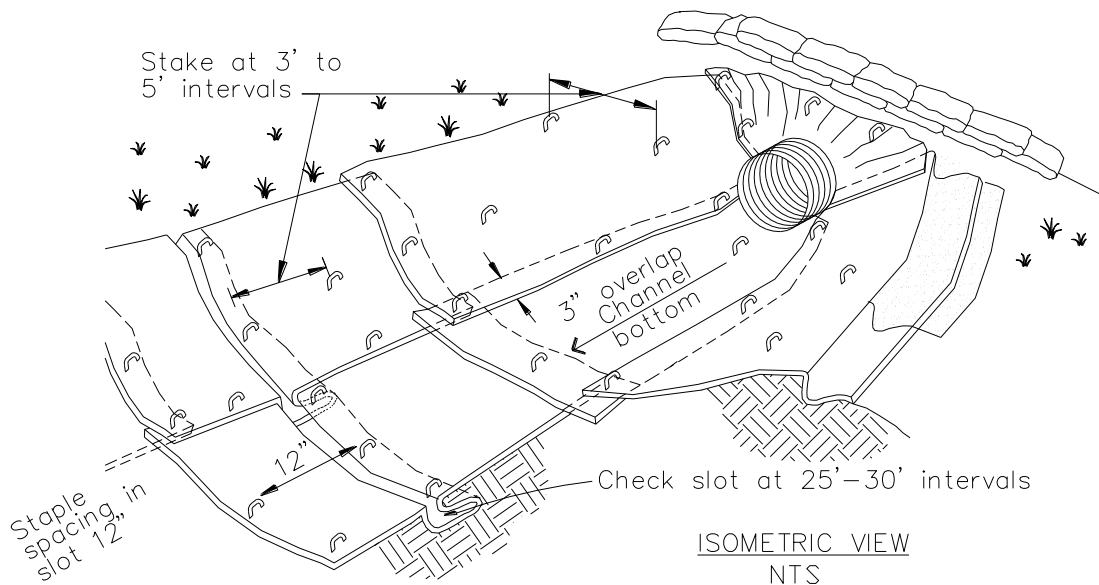

ISOMETRIC VIEW
NTS

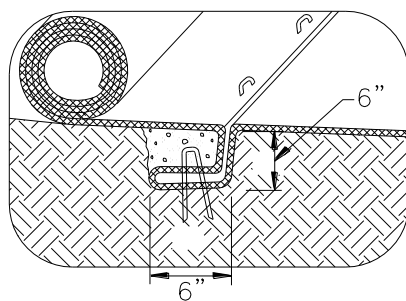

INTERMITTENT CHECK SLOT
NTS

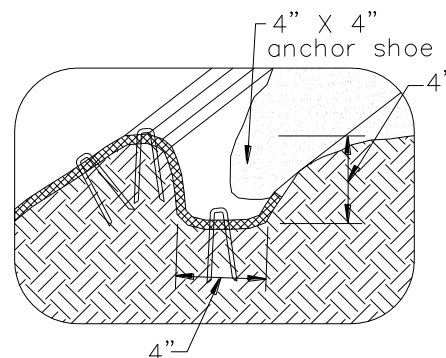

LONGITUDINAL ANCHOR TRENCH
NTS

NOTES:

1. Check slots to be constructed per manufacturers specifications.
2. Staking or stapling layout per manufacturers specifications.
3. Install per manufacturer's recommendations

TYPICAL INSTALLATION DETAIL



Description and Purpose

Wood mulching consists of applying a mixture of shredded wood mulch, bark or compost to disturbed soils. The primary function of wood mulching is to reduce erosion by protecting bare soil from rainfall impact, increasing infiltration, and reducing runoff.

Suitable Applications

Wood mulching is suitable for disturbed soil areas requiring temporary protection until permanent stabilization is established.

Limitations

- Not suitable for use on slopes steeper than 3:1 (H:V). Best suited to flat areas or gentle slopes or 5:1 (H:V) or flatter.
- Wood mulch and compost may introduce unwanted species.
- Not suitable for areas exposed to concentrated flows.
- May need to be removed prior to further earthwork.

Implementation

Mulch Selection

There are many types of mulches. Selection of the appropriate type of mulch should be based on the type of application, site conditions, and compatibility with planned or future uses.

Categories

EC	Erosion Control	<input checked="" type="checkbox"/>
SE	Sediment Control	
TC	Tracking Control	
WE	Wind Erosion Control	<input checked="" type="checkbox"/>
NS	Non-Stormwater Management Control	
WM	Waste Management and Materials Pollution Control	

Legend:

- Primary Objective
- Secondary Objective

Targeted Constituents

Sediment	<input checked="" type="checkbox"/>
Nutrients	
Trash	
Metals	
Bacteria	
Oil and Grease	
Organics	

Potential Alternatives

- EC-3 Hydraulic Mulch
- EC-4 Hydroseeding
- EC-5 Soil Binders
- EC-6 Straw Mulch
- EC-7 Geotextiles and Mats

If User/Subscriber modifies this fact sheet in any way, the CASQA name/logo and footer below must be removed from each page and not appear on the modified version.



Application Procedures

Prior to application, after existing vegetation has been removed, roughen embankment and fill areas by rolling with a device such as a punching type roller or by track walking. The construction application procedures for mulches vary significantly depending upon the type of mulching method specified. Two methods are highlighted here:

- **Green Material:** This type of mulch is produced by the recycling of vegetation trimmings such as grass, shredded shrubs, and trees. Methods of application are generally by hand although pneumatic methods are available.
 - Green material can be used as a temporary ground cover with or without seeding.
 - The green material should be evenly distributed on site to a depth of not more than 2 in.
- **Shredded Wood:** Suitable for ground cover in ornamental or revegetated plantings.
 - Shredded wood/bark is conditionally suitable. See note under limitations.
 - Distribute by hand or use pneumatic methods.
 - Evenly distribute the mulch across the soil surface to a depth of 2 to 3 in.
- Avoid mulch placement onto roads, sidewalks, drainage channels, existing vegetation, etc.

Costs

Average annual cost for installation and maintenance (3-4 months useful life) is around \$4,000 per acre, but cost can increase if the source is not close to the project site.

Inspection and Maintenance

- Inspect BMPs in accordance with General Permit requirements for the associated project type and risk level. It is recommended that at a minimum, BMPs be inspected weekly, prior to forecasted rain events, daily during extended rain events, and after the conclusion of rain events.
- Areas where erosion is evident shall be repaired and BMPs reapplied as soon as possible. Care should be exercised to minimize the damage to protected areas while making repairs, as any area damaged will require reapplication of BMPs.
- Regardless of the mulching technique selected, the key consideration in inspection and maintenance is that the mulch needs to last long enough to achieve erosion control objectives. If the mulch is applied as a stand alone erosion control method over disturbed areas (without seed), it should last the length of time the site will remain barren or until final re-grading and revegetation.
- Where vegetation is not the ultimate cover, such as ornamental and landscape applications of bark or wood chips, inspection and maintenance should focus on longevity and integrity of the mulch.
- Reapply mulch when bare earth becomes visible.

References

Controlling Erosion of Construction Sites Agriculture Information Bulletin #347, U.S. Department of Agriculture (USDA), Natural Resources Conservation Service (NRCS) (formerly Soil Conservation Service – SCS).

Guides for Erosion and Sediment Control in California, USDA Soils Conservation Service, January 1991.

Manual of Standards of Erosion and Sediment Control Measures, Association of Bay Area Governments, May 1995.

Proposed Guidance Specifying Management Measures for Sources of Nonpoint Pollution in Coastal Waters, Work Group Working Paper, USEPA, April 1992.

Sedimentation and Erosion Control, An Inventory of Current Practices Draft, U.S. EPA, April 1990.

Soil Erosion by Water Agricultural Information Bulletin #513, U.S. Department of Agriculture, Soil Conservation Service.

Stormwater Quality Handbooks Construction Site Best Management Practices (BMPs) Manual, State of California Department of Transportation (Caltrans), November 2000.

Water Quality Management Plan for the Lake Tahoe Region, Volume II, Handbook of Management Practices, Tahoe Regional Planning Agency, November 1988.

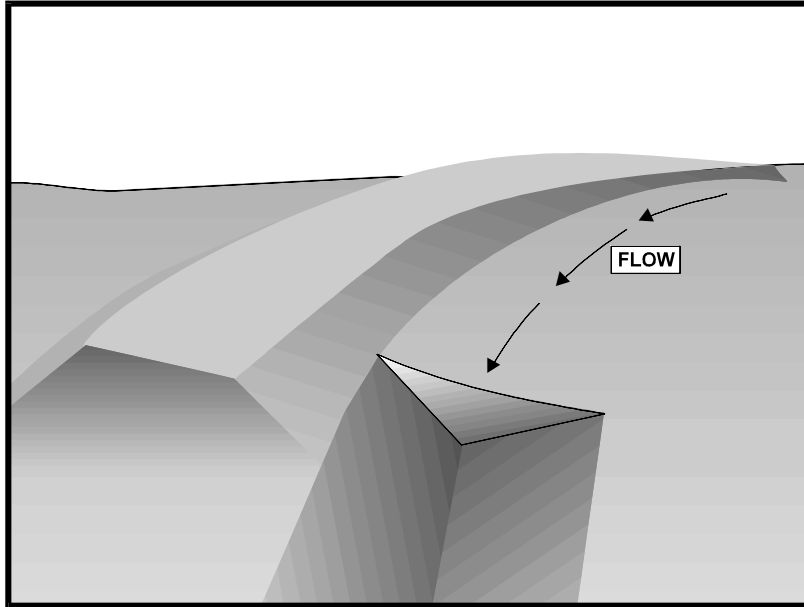

Description and Purpose

An earth dike is a temporary berm or ridge of compacted soil used to divert runoff or channel water to a desired location. A drainage swale is a shaped and sloped depression in the soil surface used to convey runoff to a desired location. Earth dikes and drainage swales are used to divert off site runoff around the construction site, divert runoff from stabilized areas and disturbed areas, and direct runoff into sediment basins or traps.

Suitable Applications

Earth dikes and drainage swales are suitable for use, individually or together, where runoff needs to be diverted from one area and conveyed to another.

- Earth dikes and drainage swales may be used:
 - To convey surface runoff down sloping land
 - To intercept and divert runoff to avoid sheet flow over sloped surfaces
 - To divert and direct runoff towards a stabilized watercourse, drainage pipe or channel
 - To intercept runoff from paved surfaces
 - Below steep grades where runoff begins to concentrate
 - Along roadways and facility improvements subject to flood drainage

Categories

EC	Erosion Control	<input checked="" type="checkbox"/>
SE	Sediment Control	<input type="checkbox"/>
TC	Tracking Control	<input type="checkbox"/>
WE	Wind Erosion Control	<input type="checkbox"/>
NS	Non-Stormwater Management Control	<input type="checkbox"/>
WM	Waste Management and Materials Pollution Control	<input type="checkbox"/>

Legend:

- Primary Objective**
- Secondary Objective**

Targeted Constituents

Sediment	<input checked="" type="checkbox"/>
Nutrients	<input type="checkbox"/>
Trash	<input type="checkbox"/>
Metals	<input type="checkbox"/>
Bacteria	<input type="checkbox"/>
Oil and Grease	<input type="checkbox"/>
Organics	<input type="checkbox"/>

Potential Alternatives

None

If User/Subscriber modifies this fact sheet in any way, the CASQA name/logo and footer below must be removed from each page and not appear on the modified version.



- At the top of slopes to divert runoff from adjacent or undisturbed slopes
- At bottom and mid slope locations to intercept sheet flow and convey concentrated flows
- Divert sediment laden runoff into sediment basins or traps

Limitations

Dikes should not be used for drainage areas greater than 10 acres or along slopes greater than 10 percent. For larger areas more permanent drainage structures should be built. All drainage structures should be built in compliance with local municipal requirements.

- Earth dikes may create more disturbed area on site and become barriers to construction equipment.
- Earth dikes must be stabilized immediately, which adds cost and maintenance concerns.
- Diverted stormwater may cause downstream flood damage.
- Dikes should not be constructed of soils that may be easily eroded.
- Regrading the site to remove the dike may add additional cost.
- Temporary drains and swales or any other diversion of runoff should not adversely impact upstream or downstream properties.
- Temporary drains and swales must conform to local floodplain management requirements.
- Earth dikes/drainage swales are not suitable as sediment trapping devices.
- It may be necessary to use other soil stabilization and sediment controls such as check dams, plastics, and blankets, to prevent scour and erosion in newly graded dikes, swales, and ditches.
- Sediment accumulation, scour depressions, and/or persistent non-stormwater discharges can result in areas of standing water suitable for mosquito production in drainage swales.

Implementation

The temporary earth dike is a berm or ridge of compacted soil, located in such a manner as to divert stormwater to a sediment trapping device or a stabilized outlet, thereby reducing the potential for erosion and offsite sedimentation. Earth dikes can also be used to divert runoff from off site and from undisturbed areas away from disturbed areas and to divert sheet flows away from unprotected slopes.

An earth dike does not itself control erosion or remove sediment from runoff. A dike prevents erosion by directing runoff to an erosion control device such as a sediment trap or directing runoff away from an erodible area. Temporary diversion dikes should not adversely impact adjacent properties and must conform to local floodplain management regulations, and should not be used in areas with slopes steeper than 10%.

Slopes that are formed during cut and fill operations should be protected from erosion by runoff. A combination of a temporary drainage swale and an earth dike at the top of a slope can divert

runoff to a location where it can be brought to the bottom of the slope (see EC-11, Slope Drains). A combination dike and swale is easily constructed by a single pass of a bulldozer or grader and compacted by a second pass of the tracks or wheels over the ridge. Diversion structures should be installed when the site is initially graded and remain in place until post construction BMPs are installed and the slopes are stabilized.

Diversion practices concentrate surface runoff, increasing its velocity and erosive force. Thus, the flow out of the drain or swale must be directed onto a stabilized area or into a grade stabilization structure. If significant erosion will occur, a swale should be stabilized using vegetation, chemical treatment, rock rip-rap, matting, or other physical means of stabilization. Any drain or swale that conveys sediment laden runoff must be diverted into a sediment basin or trap before it is discharged from the site.

General

- Care must be applied to correctly size and locate earth dikes, drainage swales. Excessively steep, unlined dikes, and swales are subject to erosion and gully formation.
- Conveyances should be stabilized.
- Use a lined ditch for high flow velocities.
- Select flow velocity based on careful evaluation of the risks due to erosion of the measure, soil types, overtopping, flow backups, washout, and drainage flow patterns for each project site.
- Compact any fills to prevent unequal settlement.
- Do not divert runoff onto other property without securing written authorization from the property owner.
- When possible, install and utilize permanent dikes, swales, and ditches early in the construction process.
- Provide stabilized outlets.

Earth Dikes

Temporary earth dikes are a practical, inexpensive BMP used to divert stormwater runoff. Temporary diversion dikes should be installed in the following manner:

- All dikes should be compacted by earth moving equipment.
- All dikes should have positive drainage to an outlet.
- All dikes should have 2:1 or flatter side slopes, 18 in. minimum height, and a minimum top width of 24 in. Wide top widths and flat slopes are usually needed at crossings for construction traffic.
- The outlet from the earth dike must function with a minimum of erosion. Runoff should be conveyed to a sediment trapping device such as a Sediment Trap (SE-3) or Sediment Basin

(SE-2) when either the dike channel or the drainage area above the dike are not adequately stabilized.

- Temporary stabilization may be achieved using seed and mulching for slopes less than 5% and either rip-rap or sod for slopes in excess of 5%. In either case, stabilization of the earth dike should be completed immediately after construction or prior to the first rain.
- If riprap is used to stabilize the channel formed along the toe of the dike, the following typical specifications apply:

Channel Grade	Riprap Stabilization
0.5-1.0%	4 in. Rock
1.1-2.0%	6 in. Rock
2.1-4.0%	8 in. Rock
4.1-5.0%	8 in. -12 in. Riprap

- The stone riprap, recycled concrete, etc. used for stabilization should be pressed into the soil with construction equipment.
- Filter cloth may be used to cover dikes in use for long periods.
- Construction activity on the earth dike should be kept to a minimum.

Drainage Swales

Drainage swales are only effective if they are properly installed. Swales are more effective than dikes because they tend to be more stable. The combination of a swale with a dike on the downhill side is the most cost effective diversion.

Standard engineering design criteria for small open channel and closed conveyance systems should be used (see the local drainage design manual). Unless local drainage design criteria state otherwise, drainage swales should be designed as follows:

- No more than 5 acres may drain to a temporary drainage swale.
- Place drainage swales above or below, not on, a cut or fill slope.
- Swale bottom width should be at least 2 ft
- Depth of the swale should be at least 18 in.
- Side slopes should be 2:1 or flatter.
- Drainage or swales should be laid at a grade of at least 1 percent, but not more than 15 percent.
- The swale must not be overtopped by the peak discharge from a 10-year storm, irrespective of the design criteria stated above.

- Remove all trees, stumps, obstructions, and other objectionable material from the swale when it is built.
- Compact any fill material along the path of the swale.
- Stabilize all swales immediately. Seed and mulch swales at a slope of less than 5 percent, and use rip-rap or sod for swales with a slope between 5 and 15 percent. For temporary swales, geotextiles and mats (EC-7) may provide immediate stabilization.
- Irrigation may be required to establish sufficient vegetation to prevent erosion.
- Do not operate construction vehicles across a swale unless a stabilized crossing is provided.
- Permanent drainage facilities must be designed by a professional engineer (see the local drainage design criteria for proper design).
- At a minimum, the drainage swale should conform to predevelopment drainage patterns and capacities.
- Construct the drainage swale with a positive grade to a stabilized outlet.
- Provide erosion protection or energy dissipation measures if the flow out of the drainage swale can reach an erosive velocity.

Costs

- Cost ranges from \$15 to \$55 per ft for both earthwork and stabilization and depends on availability of material, site location, and access.
- Small dikes: \$2.50 - \$6.50/linear ft; Large dikes: \$2.50/yd³.
- The cost of a drainage swale increases with drainage area and slope. Typical swales for controlling internal erosion are inexpensive, as they are quickly formed during routine earthwork.

Inspection and Maintenance

- Inspect BMPs prior to forecast rain, daily during extended rain events, after rain events, weekly during the rainy season, and at two-week intervals during the non-rainy season.
- Inspect BMPs subject to non-stormwater discharges daily while non-stormwater discharges occur.
- Inspect ditches and berms for washouts. Replace lost riprap, damaged linings or soil stabilizers as needed.
- Inspect channel linings, embankments, and beds of ditches and berms for erosion and accumulation of debris and sediment. Remove debris and sediment and repair linings and embankments as needed.
- Temporary conveyances should be completely removed as soon as the surrounding drainage area has been stabilized or at the completion of construction

References

Erosion and Sediment Control Handbook, S.J. Goldman, K. Jackson, T.A. Bursetynsky, P.E., McGraw Hill Book Company, 1986.

Manual of Standards of Erosion and Sediment Control Measures, Association of Bay Area Governments, May 1995.

Metzger, M.E. 2004. Managing mosquitoes in stormwater treatment devices. University of California Division of Agriculture and Natural Resources, Publication 8125. On-line: <http://anrcatalog.ucdavis.edu/pdf/8125.pdf>

National Association of Home Builders (NAHB). Stormwater Runoff & Nonpoint Source Pollution Control Guide for Builders and Developers. National Association of Home Builders, Washington, D.C., 1995

National Management Measures to Control Nonpoint Source Pollution from Urban Areas, United States Environmental Protection Agency, 2002.

Southeastern Wisconsin Regional Planning Commission (SWRPC). Costs of Urban Nonpoint Source Water Pollution Control Measures. Technical Report No. 31. Southeastern Wisconsin Regional Planning Commission, Waukesha, WI. 1991

Stormwater Quality Handbooks Construction Site Best Management Practices (BMPs) Manual, State of California Department of Transportation (Caltrans), November 2000.

Stormwater Management of the Puget Sound Basin, Technical Manual, Publication #91-75, Washington State Department of Ecology, February 1992.

Water Quality Management Plan for the Lake Tahoe Region, Volume II, Handbook of Management Practices, Tahoe Regional Planning Agency, November 1988.

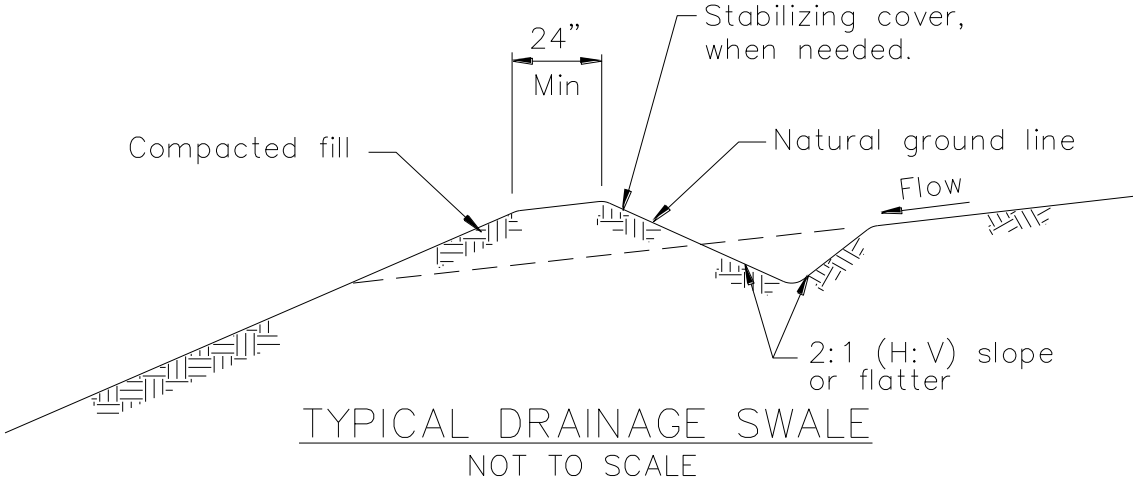

NOTES:

- 1. Stabilize inlet, outlets and slopes.
- 2. Properly compact the subgrade.

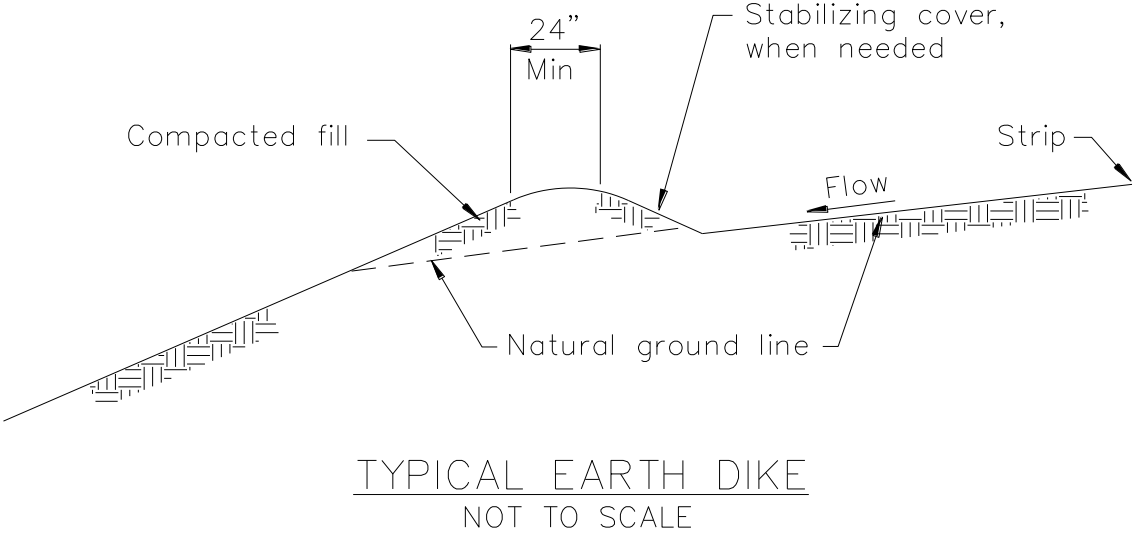

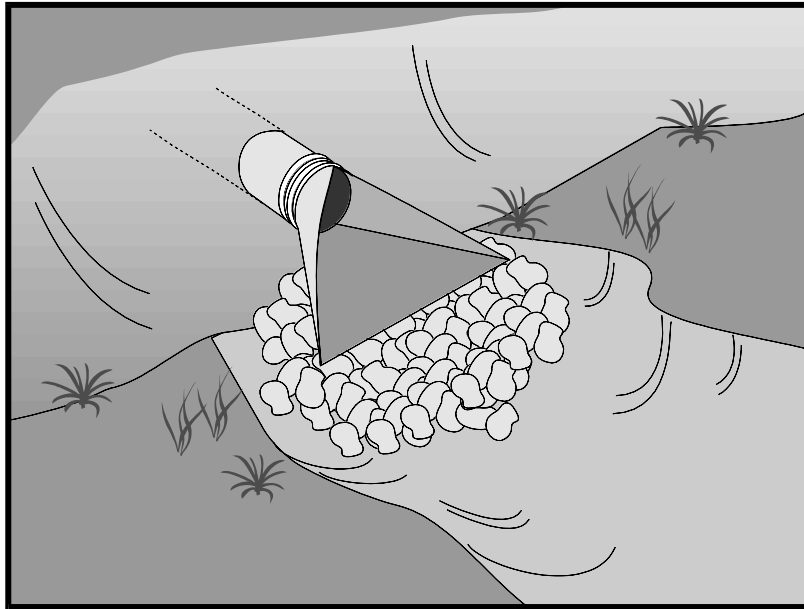

Description and Purpose

Outlet protection is a physical device composed of rock, grouted riprap, or concrete rubble, which is placed at the outlet of a pipe or channel to prevent scour of the soil caused by concentrated, high velocity flows.

Suitable Applications

Whenever discharge velocities and energies at the outlets of culverts, conduits, or channels are sufficient to erode the next downstream reach. This includes temporary diversion structures to divert runoff during construction.

- These devices may be used at the following locations:
 - Outlets of pipes, drains, culverts, slope drains, diversion ditches, swales, conduits, or channels.
 - Outlets located at the bottom of mild to steep slopes.
 - Discharge outlets that carry continuous flows of water.
 - Outlets subject to short, intense flows of water, such as flash floods.
 - Points where lined conveyances discharge to unlined conveyances

Limitations

- Large storms or high flows can wash away the rock outlet protection and leave the area susceptible to erosion.

Categories

EC	Erosion Control	<input checked="" type="checkbox"/>
SE	Sediment Control	
TC	Tracking Control	
WE	Wind Erosion Control	
NS	Non-Stormwater Management Control	
WM	Waste Management and Materials Pollution Control	

Legend:

- Primary Objective**
- Secondary Objective**

Targeted Constituents

Sediment	<input checked="" type="checkbox"/>
Nutrients	
Trash	
Metals	
Bacteria	
Oil and Grease	
Organics	

Potential Alternatives

None

If User/Subscriber modifies this fact sheet in any way, the CASQA name/logo and footer below must be removed from each page and not appear on the modified version.



- Sediment captured by the rock outlet protection may be difficult to remove without removing the rock.
- Outlet protection may negatively impact the channel habitat.
- Grouted riprap may break up in areas of freeze and thaw.
- If there is not adequate drainage, and water builds up behind grouted riprap, it may cause the grouted riprap to break up due to the resulting hydrostatic pressure.
- Sediment accumulation, scour depressions, and/or persistent non-stormwater discharges can result in areas of standing water suitable for mosquito production in velocity dissipation devices.

Implementation

General

Outlet protection is needed where discharge velocities and energies at the outlets of culverts, conduits or channels are sufficient to erode the immediate downstream reach. This practice protects the outlet from developing small eroded pools (plunge pools), and protects against gully erosion resulting from scouring at a culvert mouth.

Design and Layout

As with most channel design projects, depth of flow, roughness, gradient, side slopes, discharge rate, and velocity should be considered in the outlet design. Compliance to local and state regulations should also be considered while working in environmentally sensitive streambeds. General recommendations for rock size and length of outlet protection mat are shown in the rock outlet protection figure in this BMP and should be considered minimums. The apron length and rock size gradation are determined using a combination of the discharge pipe diameter and estimate discharge rate: Select the longest apron length and largest rock size suggested by the pipe size and discharge rate. Where flows are conveyed in open channels such as ditches and swales, use the estimated discharge rate for selecting the apron length and rock size. Flows should be same as the culvert or channel design flow but never the less than the peak 5 year flow for temporary structures planned for one rainy season, or the 10 year peak flow for temporary structures planned for two or three rainy seasons.

- There are many types of energy dissipaters, with rock being the one that is represented in the attached figure.
- Best results are obtained when sound, durable, and angular rock is used.
- Install riprap, grouted riprap, or concrete apron at selected outlet. Riprap aprons are best suited for temporary use during construction. Grouted or wired tied rock riprap can minimize maintenance requirements.
- Rock outlet protection is usually less expensive and easier to install than concrete aprons or energy dissipaters. It also serves to trap sediment and reduce flow velocities.
- Carefully place riprap to avoid damaging the filter fabric.

- Stone 4 in. to 6 in. may be carefully dumped onto filter fabric from a height not to exceed 12 in.
 - Stone 8 in. to 12 in. must be hand placed onto filter fabric, or the filter fabric may be covered with 4 in. of gravel and the 8 in. to 12 in. rock may be dumped from a height not to exceed 16 in.
 - Stone greater than 12 in. shall only be dumped onto filter fabric protected with a layer of gravel with a thickness equal to one half the D_{50} rock size, and the dump height limited to twice the depth of the gravel protection layer thickness.
- For proper operation of apron: Align apron with receiving stream and keep straight throughout its length. If a curve is needed to fit site conditions, place it in upper section of apron.
 - Outlets on slopes steeper than 10 percent should have additional protection.

Costs

Costs are low if material is readily available. If material is imported, costs will be higher. Average installed cost is \$150 per device.

Inspection and Maintenance

- Inspect BMPs in accordance with General Permit requirements for the associated project type and risk level. It is recommended that at a minimum, BMPs be inspected weekly, prior to forecasted rain events, daily during extended rain events, and after the conclusion of rain events.
- Inspect BMPs subjected to non-stormwater discharges daily while non-stormwater discharges occur. Minimize areas of standing water by removing sediment blockages and filling scour depressions.
- Inspect apron for displacement of the riprap and damage to the underlying fabric. Repair fabric and replace riprap that has washed away. If riprap continues to wash away, consider using larger material.
- Inspect for scour beneath the riprap and around the outlet. Repair damage to slopes or underlying filter fabric immediately.
- Temporary devices should be completely removed as soon as the surrounding drainage area has been stabilized or at the completion of construction.

References

County of Sacramento Improvement Standards, Sacramento County, May 1989.

Erosion and Sediment Control Handbook, S.J. Goldman, K. Jackson, T.A. Bursztynsky, P.E., McGraw Hill Book Company, 1986.

Handbook of Steel Drainage & Highway Construction, American Iron and Steel Institute, 1983.

Manual of Standards of Erosion and Sediment Control Measures, Association of Bay Area Governments, May 1995.

Metzger, M.E. 2004. Managing mosquitoes in stormwater treatment devices. University of California Division of Agriculture and Natural Resources, Publication 8125. On-line: <http://anrcatalog.ucdavis.edu/pdf/8125.pdf>

Stormwater Quality Handbooks Construction Site Best Management Practices (BMPs) Manual, state of California Department of Transportation (Caltrans), November 2000.

Stormwater Management of the Puget Sound Basin, Technical Manual, Publication #91-75, Washington State Department of Ecology, February 1992.

Water Quality Management Plan for the Lake Tahoe Region, Volume II, Handbook of Management Practices, Tahoe Regional Planning Agency, November 1988.

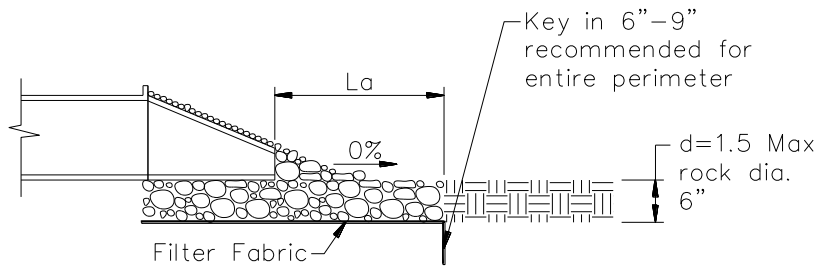
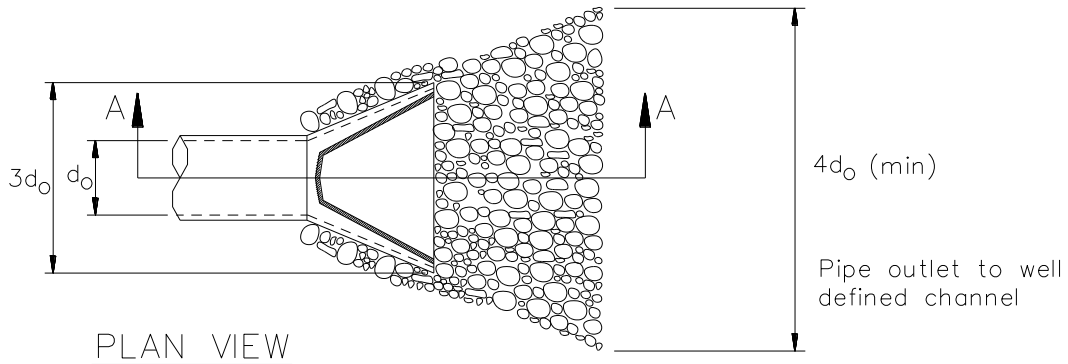

Pipe Diameter inches	Discharge ft ³ /s	Apron Length, L _a ft	Rip Rap D ₅₀ Diameter Min inches
12	5	10	4
	10	13	6
18	10	10	6
	20	16	8
	30	23	12
24	40	26	16
	30	16	8
	40	26	8
	50	26	12
	60	30	16

For larger or higher flows consult a Registered Civil Engineer
 Source: USDA - SCS

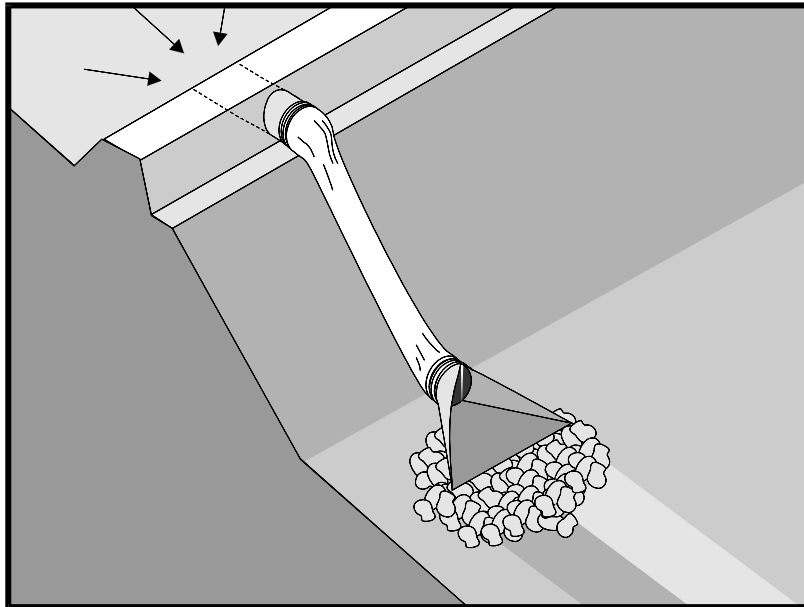

Description and Purpose

A slope drain is a pipe used to intercept and direct surface runoff or groundwater into a stabilized watercourse, trapping device, or stabilized area. Slope drains are used with earth dikes and drainage ditches to intercept and direct surface flow away from slope areas to protect cut or fill slopes.

Suitable Applications

- Where concentrated flow of surface runoff must be conveyed down a slope in order to prevent erosion.
- Drainage for top of slope diversion dikes or swales.
- Drainage for top of cut and fill slopes where water can accumulate.
- Emergency spillway for a sediment basin.

Limitations

Installation is critical for effective use of the pipe slope drain to minimize potential gully erosion.

- Maximum drainage area per slope drain is 10 acres. (For large areas use a paved chute, rock lined channel, or additional pipes.)
- Severe erosion may result when slope drains fail by overtopping, piping, or pipe separation.

Categories

EC	Erosion Control	<input checked="" type="checkbox"/>
SE	Sediment Control	
TC	Tracking Control	
WE	Wind Erosion Control	
NS	Non-Stormwater Management Control	
WM	Waste Management and Materials Pollution Control	

Legend:

- Primary Objective
- Secondary Objective

Targeted Constituents

Sediment	<input checked="" type="checkbox"/>
Nutrients	
Trash	
Metals	
Bacteria	
Oil and Grease	
Organics	

Potential Alternatives

EC-9 Earth Dike, Drainage Swales

If User/Subscriber modifies this fact sheet in any way, the CASQA name/logo and footer below must be removed from each page and not appear on the modified version.



- During large storms, pipe slope drains may become clogged or over charged, forcing water around the pipe and causing extreme slope erosion.
- If the sectional down drain is not sized correctly, the runoff can spill over the drain sides causing gully erosion and potential failure of the structure.
- Dissipation of high flow velocities at the pipe outlet is required to avoid downstream erosion.
- Sediment accumulation, scour depressions, and/or persistent non-stormwater discharges can result in areas of standing water suitable for mosquito production in energy dissipaters associated with slope drain outlets.

Implementation

General

The slope drain is applicable for any construction site where concentrated surface runoff can accumulate and must be conveyed down the slope in order to prevent erosion. The slope drain is effective because it prevents the stormwater from flowing directly down the slope by confining all the runoff into an enclosed pipe or channel. Due to the time lag between grading slopes and installation of permanent stormwater collection systems and slope stabilization measures, temporary provisions to intercept runoff are sometimes necessary. Particularly in steep terrain, slope drains can protect unstabilized areas from erosion.

Installation

The slope drain may be a rigid pipe, such as corrugated metal, a flexible conduit, or a lined terrace drain with the inlet placed on the top of a slope and the outlet at the bottom of the slope. This BMP typically is used in combination with a diversion control, such as an earth dike or drainage swale at the top of the slope.

The following criteria must be considered when siting slope drains.

- Permanent structures included in the project plans can often serve as construction BMPs if implemented early. However, the permanent structure must meet or exceed the criteria for the temporary structure.
- Inlet structures must be securely entrenched and compacted to avoid severe gully erosion.
- Slope drains must be securely anchored to the slope and must be adequately sized to carry the capacity of the design storm and associated forces.
- Outlets must be stabilized with riprap, concrete or other type of energy dissipator, or directed into a stable sediment trap or basin. See EC-10, Velocity Dissipation Devices.
- Debris racks are recommended at the inlet. Debris racks located several feet upstream of the inlet can usually be larger than racks at the inlet, and thus provide enhanced debris protection and less plugging.
- Safety racks are also recommended at the inlet and outlet of pipes where children or animals could become entrapped.
- Secure inlet and surround with dikes to prevent gully erosion and anchor pipe to slope.

- When using slope drains, limit drainage area to 10 acres per pipe. For larger areas, use a rock lined channel or a series of pipes.
- Size to convey at least the peak flow of a 10-year storm. The design storm is conservative due to the potential impact of system failures.
- Maximum slope generally limited to 2:1 (H:V) as energy dissipation below steeper slopes is difficult.
- Direct surface runoff to slope drains with interceptor dikes. See BMP EC-9, Earth Dikes and Drainage Swales. Top of interceptor dikes should be 12 in. higher than the top of the slope drain.
- Slope drains can be placed on or buried underneath the slope surface.
- Recommended materials include both metal and plastic pipe, either corrugated or smooth wall. Concrete pipe can also be used.
- When installing slope drains:
 - Install slope drains perpendicular to slope contours.
 - Compact soil around and under entrance, outlet, and along length of pipe.
 - Securely anchor and stabilize pipe and appurtenances into soil.
 - Check to ensure that pipe connections are watertight.
 - Protect area around inlet with filter cloth. Protect outlet with riprap or other energy dissipation device. For high energy discharges, reinforce riprap with concrete or use reinforced concrete device.
 - Protect outlet of slope drains using a flared end section when outlet discharges to a flexible energy dissipation device.
 - A flared end section installed at the inlet will improve flow into the slope drain and prevent erosion at the pipe entrance. Use a flared end section with a 6 in. minimum toe plate to help prevent undercutting. The flared section should slope towards the pipe inlet.

Design and Layout

The capacity for temporary drains should be sufficient to convey at least the peak runoff from a 10-year rainfall event. The pipe size may be computed using the Rational Method or a method established by the local municipality. Higher flows must be safely stored or routed to prevent any offsite concentration of flow and any erosion of the slope. The design storm is purposely conservative due to the potential impacts associated with system failures.

As a guide, temporary pipe slope drains should not be sized smaller than shown in the following table:

Minimum Pipe Diameter (Inches)	Maximum Drainage Area (Acres)
12	1.0
18	3.0
21	5.0
24	7.0
30	10.0

Larger drainage areas can be treated if the area can be subdivided into areas of 10 acres or less and each area is treated as a separate drainage. Drainage areas exceeding 10 acres must be designed by a Registered Civil Engineer and approved by the agency that issued the grading permit.

Materials:

Soil type, rainfall patterns, construction schedule, local requirements, and available supply are some of the factors to be considered when selecting materials. The following types of slope drains are commonly used:

- **Rigid Pipe:** This type of slope drain is also known as a pipe drop. The pipe usually consists of corrugated metal pipe or rigid plastic pipe. The pipe is placed on undisturbed or compacted soil and secured onto the slope surface or buried in a trench. Concrete thrust blocks must be used when warranted by the calculated thrust forces. Collars should be properly installed and secured with metal strappings or watertight collars.
- **Flexible Pipe:** The flexible pipe slope drain consists of a flexible tube of heavy duty plastic, rubber, or composite material. The tube material is securely anchored onto the slope surface. The tube should be securely fastened to the metal inlet and outlet conduit sections with metal strappings or watertight collars.
- **Section Downdrains:** The section downdrain consists of pre-fabricated, section conduit of half round or third round material. The sectional downdrain performs similar to a flume or chute. The pipe must be placed on undisturbed or compacted soil and secured into the slope.
- **Concrete-lined Terrace Drain:** This is a concrete channel for draining water from a terrace on a slope to the next level. These drains are typically specified as permanent structures and if installed early, can serve as slope drains during construction, which should be designed according to local drainage design criteria.

Costs

- Cost varies based on pipe selection and selected outlet protection.

Corrugated Steel Pipes, Per Foot	
Size	Supplied and Installed Cost (No Trenching Included)
12"	\$19.60 per LF
15"	\$22.00
18"	\$26.00
24"	\$32.00
30"	\$50.00
PVC Pipes, Per Foot	
Size	Supplied and Installed Cost (No Trenching Included)
12"	\$24.50
14"	\$49.00
16"	\$51.00
18"	\$54.00
20"	\$66.00
24"	\$93.00
30"	\$130.00

Inspection and Maintenance

- Inspect BMPs in accordance with General Permit requirements for the associated project type and risk level. It is recommended that at a minimum, BMPs be inspected weekly, prior to forecasted rain events, daily during extended rain events, and after the conclusion of rain events.
- Inspect BMPs subjected to non-stormwater discharges daily while non-stormwater discharges occur. Minimize areas of standing water by removing sediment blockages and filling scour depressions.
- Inspect outlet for erosion and downstream scour. If eroded, repair damage and install additional energy dissipation measures. If downstream scour is occurring, it may be necessary to reduce flows being discharged into the channel unless other preventative measures are implemented.
- Insert inlet for clogging or undercutting. Remove debris from inlet to maintain flows. Repair undercutting at inlet and if needed, install flared section or rip rap around the inlet to prevent further undercutting.
- Inspect pipes for leakage. Repair leaks and restore damaged slopes.
- Inspect slope drainage for accumulations of debris and sediment.

- Remove built up sediment from entrances and outlets as required. Flush drains if necessary; capture and settle out sediment from discharge.
- Make sure water is not ponding onto inappropriate areas (e.g., active traffic lanes, material storage areas, etc.).
- Pipe anchors must be checked to ensure that the pipe remains anchored to the slope. Install additional anchors if pipe movement is detected.

References

Draft – Sedimentation and Erosion Control, An Inventory of Current Practices, U.S.E.P.A., April 1990.

Metzger, M.E. 2004. Managing mosquitoes in stormwater treatment devices. University of California Division of Agriculture and Natural Resources, Publication 8125. On-line: <http://anrcatalog.ucdavis.edu/pdf/8125.pdf>

National Association of Home Builders (NAHB). Stormwater Runoff & Nonpoint Source Pollution Control Guide for Builders and Developers. National Association of Home Builders, Washington, D.C., 1995

National Management Measures to Control Nonpoint Source Pollution from Urban Areas, United States Environmental Protection Agency, 2002.

Stormwater Quality Handbooks Construction Site Best Management Practices (BMPs) Manual, State of California Department of Transportation (Caltrans), November 2000.

Stormwater Management of the Puget Sound Basin, Technical Manual, Publication #91-75, Washington State Department of Ecology, February 1992.

Water Quality Management Plan for the Lake Tahoe Region, Volume II, Handbook of Management Practices, Tahoe Regional Planning Agency, November 1988.

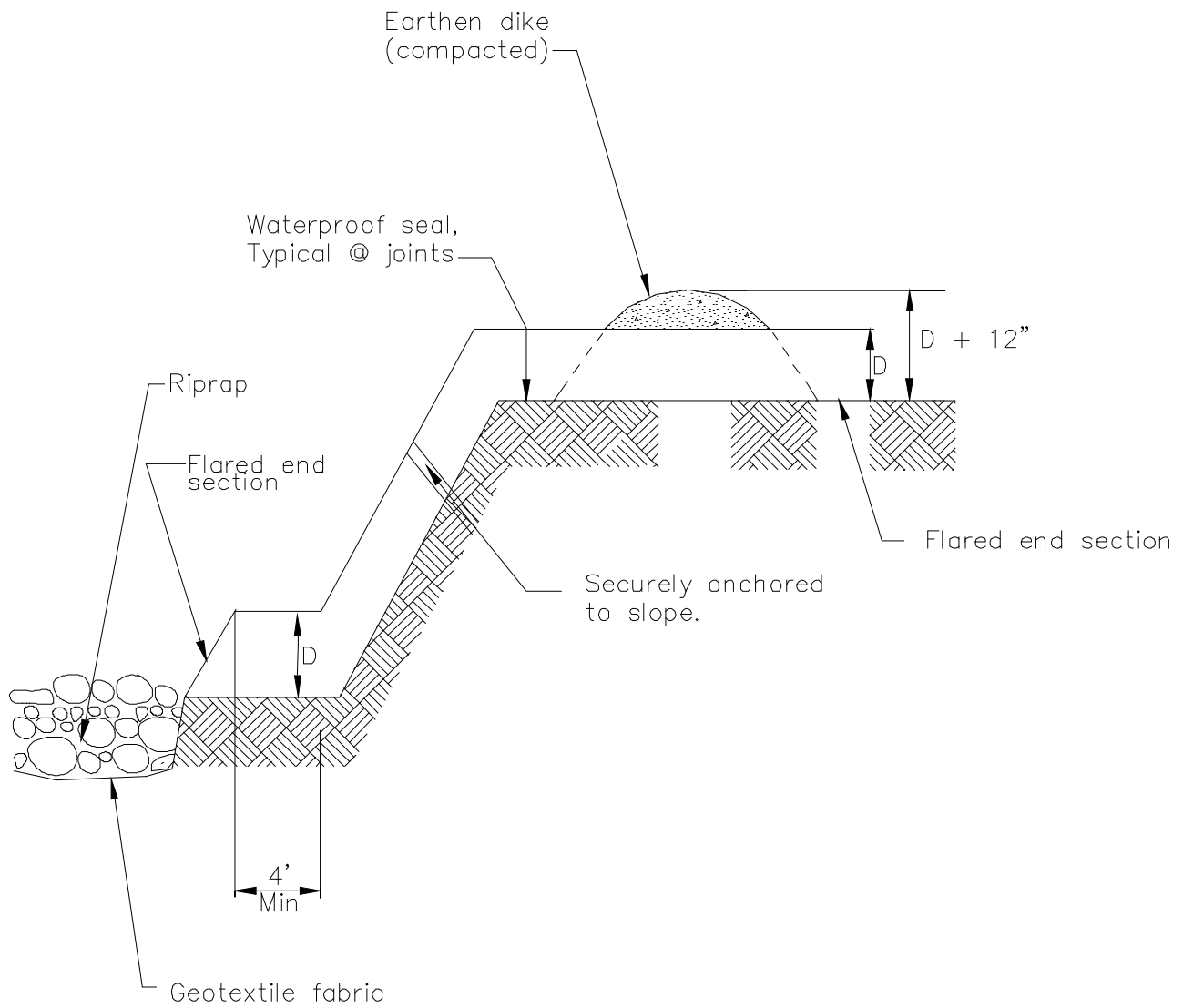

TYPICAL SLOPE DRAIN
NOT TO SCALE



Description and Purpose

Stream channels, streambanks, and associated riparian areas are dynamic and sensitive ecosystems that respond to changes in land use activity. Streambank and channel disturbance resulting from construction activities can increase the stream's sediment load, which can cause channel erosion or sedimentation and have adverse affects on the biotic system. BMPs can reduce the discharge of sediment and other pollutants to minimize the impact of construction activities on watercourses. Streams on the 303(d) list and listed for sediment may require numerous measures to prevent any increases in sediment load to the stream.

Suitable Applications

These procedures typically apply to all construction projects that disturb or occur within stream channels and their associated riparian areas.

Limitations

Specific permit requirements or mitigation measures such as Regional Water Quality Control Board (RWQCB) 401 Certification, U.S. Army Corps of Engineers 404 permit and approval by California Department of Fish and Game supercede the guidance in this BMP.

- If numerical based water quality standards are mentioned in any of these and other related permits, testing and sampling may be required. Streams listed as 303(d) impaired for sediment, silt, or turbidity, are required to

Categories

EC	Erosion Control	<input checked="" type="checkbox"/>
SE	Sediment Control	<input checked="" type="checkbox"/>
TC	Tracking Control	
WE	Wind Erosion Control	
NS	Non-Stormwater Management Control	<input checked="" type="checkbox"/>
WM	Waste Management and Materials Pollution Control	

Legend:

- Primary Objective
- Secondary Objective

Targeted Constituents

Sediment	<input checked="" type="checkbox"/>
Nutrients	
Trash	
Metals	
Bacteria	
Oil and Grease	
Organics	

Potential Alternatives

Combination of erosion and sediment controls.

If User/Subscriber modifies this fact sheet in any way, the CASQA name/logo and footer below must be removed from each page and not appear on the modified version.



conduct sampling to verify that there is no net increase in sediment load due to construction activities.

Implementation

Planning

- Proper planning, design, and construction techniques can minimize impacts normally associated with in stream construction activities. Poor planning can adversely affect soil, fish, wildlife resources, land uses, or land users. Planning should take into account: scheduling; avoidance of in-stream construction; minimizing disturbance area and construction time period; using pre-disturbed areas; selecting crossing location; and selecting equipment.

Scheduling

- Construction activities should be scheduled according to the relative sensitivity of the environmental concerns and in accordance with EC-1, Scheduling. Scheduling considerations will be different when working near perennial streams vs. ephemeral streams and are as follows.
- When in-stream construction is conducted in a perennial stream, work should optimally be performed during the rainy season. This is because in the summer, any sediment-containing water that is discharged into the watercourse will cause a large change in both water clarity and water chemistry. During the rainy season, there is typically more and faster flowing water in the stream so discharges are diluted faster. However, should in-stream work be scheduled for summer, establishing an isolation area, or diverting the stream, will significantly decrease the amount of sediment stirred up by construction work. Construction work near perennial streams should optimally be performed during the dry season (see below).
- When working in or near ephemeral streams, work should be performed during the dry season. By their very nature, ephemeral streams are usually dry in the summer, and therefore, in-stream construction activities will not cause significant water quality problems. However, when tying up the site at the end of the project, wash any fines (see Washing Fines) that accumulated in the channel back into the bed material, to decrease pollution from the first rainstorm of the season.
- When working near ephemeral or perennial streams, erosion and sediment controls (see silt fences, straw bale barriers, etc.) should be implemented to keep sediment out of stream channel.

Minimize Disturbance

- Minimize disturbance through: selection of the narrowest crossing location; limiting the number of equipment trips across a stream during construction; and, minimizing the number and size of work areas (equipment staging areas and spoil storage areas). Place work areas at least 50 ft from stream channel. Field reconnaissance should be conducted during the planning stage to identify work areas.

Use of Pre-Disturbed Areas

- Locate project sites and work areas in areas disturbed by prior construction or other activity when possible.

Selection of Project Site

- Avoid steep and unstable banks, highly erodible or saturated soils, or highly fractured rock.
- Select project site that minimizes disturbance to aquatic species or habitat.

Equipment Selection

- Select equipment that reduces the amount of pressure exerted on the ground surface, and therefore, reduces erosion potential and/or use overhead or aerial access for transporting equipment across drainage channels. Use equipment that exerts ground pressures of less than 5 or 6 lb/in², where possible. Low ground pressure equipment includes: wide or high flotation tires (34 to 72 in. wide); dual tires; bogie axle systems; tracked machines; lightweight equipment; and, central tire inflation systems.

Streambank Stabilization

Preservation of Existing Vegetation

- Preserve existing vegetation in accordance with EC-2, Preservation of Existing Vegetation. In a streambank environment, preservation of existing vegetation provides the following benefits.

Water Quality Protection

- Vegetated buffers on slopes trap sediment and promote groundwater recharge. The buffer width needed to maintain water quality ranges from 15 to 100 ft. On gradual slopes, most of the filtering occurs within the first 30 ft. Steeper slopes require a greater width of vegetative buffer to provide water quality benefits.

Streambank Stabilization

- The root system of riparian vegetation stabilizes streambanks by increasing tensile strength in the soil. The presence of vegetation modifies the moisture condition of slopes (infiltration, evapo transpiration, interception) and increases bank stability.

Riparian Habitat

- Buffers of diverse riparian vegetation provide food and shelter for riparian and aquatic organisms. Minimizing impacts to fisheries habitat is a major concern when working near streams and rivers. Riparian vegetation provides shade, shelter, organic matter (leaf detritus and large woody debris), and other nutrients that are necessary for fish and other aquatic organisms. Buffer widths for habitat concerns are typically wider than those recommended for water quality concerns (100 to 1500 ft).
- When working near watercourses, it is important to understand the work site's placement in the watershed. Riparian vegetation in headwater streams has a greater impact on overall water quality than vegetation in downstream reaches. Preserving existing vegetation upstream is necessary to maintain water quality, minimize bank failure, and maximize riparian habitat, downstream of the work site.

Limitations

- Local county and municipal ordinances regarding width, extent and type of vegetative buffer required may exceed the specifications provided here; these ordinances should be investigated prior to construction.

Streambank Stabilization Specific Installation

- As a general rule, the width of a buffer strip between a road and the stream is recommended to be 50 ft plus four times the percent slope of the land, measured between the road and the top of stream bank.

Hydraulic Mulch

- Apply hydraulic mulch on disturbed streambanks above mean high water level in accordance with EC-3, Hydraulic Mulch to provide temporary soil stabilization.

Limitations

- Do not place hydraulic mulch or tackifiers below the mean high water level, as these materials could wash into the channel and impact water quality or possibly cause eutrophication (eutrophication is an algal bloom caused by excessively high nutrient levels in the water).

Hydroseeding

- Hydroseed disturbed streambanks in accordance with EC-4, Hydroseeding.

Limitations

- Do not place tackifiers or fertilizers below the mean high water level, as these materials could wash into the channel and impact water quality or possibly cause eutrophication.

Soil Binders

- Apply soil binders to disturbed streambanks in accordance with EC-5, Soil Binders.

Limitations

- Do not place soil binders below the mean high water level. Soil binder must be environmentally benign and non-toxic to aquatic organisms.

Straw Mulch

- Apply straw mulch to disturbed streambanks in accordance with EC-6, Straw Mulch.

Limitations

- Do not place straw mulch below the mean high water level, as this material could wash into the channel and impact water quality or possibly cause eutrophication.

Geotextiles and Mats

- Install geotextiles and mats as described in EC-7, Geotextiles and Mats, to stabilize disturbed channels and streambanks. Not all applications should be in the channel, for example, certain geotextile netting may snag fish gills and are not appropriate in fish bearing streams. Geotextile fabrics that are not biodegradable are not appropriate for in stream use. Additionally, geotextile fabric or blankets placed in channels must be adequate to sustain anticipated hydraulic forces.

Earth Dikes, Drainage Swales, and Lined Ditches

- Convey, intercept, or divert runoff from disturbed streambanks using EC-9, Earth Dikes and Drainage Swales.

Limitations

- Do not place earth dikes in watercourses, as these structures are only suited for intercepting sheet flow, and should not be used to intercept concentrated flow.
- Appropriately sized velocity dissipation devices (EC-10) must be placed at outlets to minimize erosion and scour.

Velocity Dissipation Devices

- Place velocity dissipation devices at outlets of pipes, drains, culverts, slope drains, diversion ditches, swales, conduits or channels in accordance with EC-10, Velocity Dissipation Devices.

Slope Drains

- Use slope drains to intercept and direct surface runoff or groundwater into a stabilized watercourse, trapping device or stabilized area in accordance with EC-11, Slope Drains.

Limitations

- Appropriately sized outlet protection and velocity dissipation devices (EC-10) must be placed at outlets to minimize erosion and scour.

Streambank Sediment Control

Silt Fences

- Install silt fences in accordance with SE-1, Silt Fence, to control sediment. Silt fences should only be installed where sediment laden water can pond, thus allowing the sediment to settle out.

Fiber Rolls

- Install fiber rolls in accordance with SE-5, Fiber Rolls, along contour of slopes above the high water level to intercept runoff, reduce flow velocity, release the runoff as sheet flow and provide removal of sediment from the runoff. In a stream environment, fiber rolls should be used in conjunction with other sediment control methods such as SE-1, Silt Fence or SE-9 Straw Bale Barrier. Install silt fence, straw bale barrier, or other erosion control method along toe of slope above the high water level.

Gravel Bag Berm

- A gravel bag berm or barrier can be utilized to intercept and slow the flow of sediment laden sheet flow runoff in accordance with SE-6, Gravel Bag Berm. In a stream environment gravel bag barriers can allow sediment to settle from runoff before water leaves the construction site and can be used to isolate the work area from the live stream.

Limitations

- Gravel bag barriers are not recommended as a perimeter sediment control practice around streams.

Straw Bale Barrier

- Install straw bale barriers in accordance with SE-9, Straw Bale Barrier, to control sediment. Straw bale barriers should only be installed where sediment laden water can pond, thus allowing the sediment to settle out. Install a silt fence in accordance with SE-1, Silt Fence,

on down slope side of straw bale barrier closest to stream channel to provide added sediment control.

Rock Filter

Description and Purpose

Rock filters are temporary erosion control barriers composed of rock that is anchored in place. Rock filters detain the sediment laden runoff, retain the sediment, and release the water as sheet flow at a reduced velocity. Typical rock filter installations are illustrated at the end of this BMP.

Applications

- Near the toe of slopes that may be subject to flow and rill erosion.

Limitations

- Inappropriate for contributing drainage areas greater than 5 acres.
- Requires sufficient space for ponded water.
- Ineffective for diverting runoff because filters allow water to slowly seep through.
- Rock filter berms are difficult to remove when construction is complete.
- Unsuitable in developed areas or locations where aesthetics is a concern.

Specifications

- Rock: open graded rock, 0.75 to 5 in. for concentrated flow applications.
- Woven wire sheathing: 1 in. diameter, hexagonal mesh, galvanized 20gauge (used with rock filters in areas of concentrated flow).
- In construction traffic areas, maximum rock berm heights should be 12 in. Berms should be constructed every 300 ft on slopes less than 5%, every 200 ft on slopes between 5% and 10%, and every 100 ft on slopes greater than 10%.

Maintenance

- Inspect and verify that activity-based BMPs are in place prior to the commencement of associated activities. While activities associated with the BMP are under way, inspect weekly during the rainy season and at two-week intervals in the non-rainy season to verify continued BMP implementation.
- Inspect BMPs subject to non-stormwater discharges daily while non-stormwater discharges occur.
- Reshape berms as needed and replace lost or dislodged rock, and filter fabric.
- Sediment that accumulates in the BMP must be periodically removed in order to maintain BMP effectiveness. Sediment should be removed when the sediment accumulation reaches one third of the barrier height. Sediment removed during maintenance may be incorporated into earthwork on the site or disposed at an appropriate location.

K-rail

Description and Purpose

This is temporary sediment control that uses K-rails to form the sediment deposition area, or to isolate the near bank construction area. Install K-rails at toe of slope in accordance with procedures described in NS-5, Clear Water Diversion.

Barriers are placed end to end in a pre-designed configuration and gravel filled bags are used at the toe of the barrier and at their abutting ends to seal and prevent movement of sediment beneath or through the barrier walls.

Appropriate Applications

- This technique is useful at the toe of embankments, cuts or fills slopes.

Limitations

- The K-rail method should not be used to dewater a project site, as the barrier is not watertight.

Implementation

- Refer to NS-5, Clear Water Diversion, for implementation requirements.

Instream Construction Sediment Control

There are three different options currently available for reducing turbidity while working in a stream or river. The stream can be isolated from the area in which work is occurring by means of a water barrier, the stream can be diverted around the work site through a pipe or temporary channel, or one can employ construction practices that minimize sediment suspension.

Whatever technique is implemented, an important thing to remember is that dilution can sometimes be the solution. A probable “worst time” to release high TSS into a stream system might be when the stream is very low; summer low flow, for example. During these times, the flow may be low while the biological activity in the stream is very high. Conversely, the addition of high TSS or sediment during a big storm discharge might have a relatively low impact, because the stream is already turbid, and the stream energy is capable of transporting both suspended solids, and large quantities of bedload through the system. The optimum time to “pull” in-stream structures may be during the rising limb of a storm hydrograph.

Techniques to minimize Total Suspended Solids (TSS)

- **Padding** - Padding laid in the stream below the work site may trap some solids that are deposited in the stream during construction. After work is done, the padding is removed from the stream, and placed on the bank to assist in re-vegetation.
- **Clean, washed gravel** - Using clean, washed gravel decreases solid suspension, as there are fewer small particles deposited in the stream.
- **Excavation using a large bucket** - Each time a bucket of soil is placed in the stream, a portion is suspended. Approximately the same amount is suspended whether a small amount of soil is placed in the stream, or a large amount. Therefore, using a large excavator bucket instead of a small one, will reduce the total amount of soil that washes downstream.

- **Use of dozer for backfilling** - Using a dozer for backfilling instead of a backhoe follows the same principles – the fewer times soil is deposited in the stream, the less soil will be suspended.
- **Partial dewatering with a pump** - Partially dewatering a stream with a pump reduces the amount of water, and thus the amount of water that can suspend sediment.

Washing Fines

Definition and Purpose

- Washing fines is an “in-channel” sediment control method, which uses water, either from a water truck or hydrant, to wash stream fines that were brought to the surface of the channel bed during restoration, back into the interstitial spaces of the gravel and cobbles.
- The purpose of this technique is to reduce or eliminate the discharge of sediment from the channel bottom during the first seasonal flow. Sediment should not be allowed into stream channels; however, occasionally in-channel restoration work will involve moving or otherwise disturbing fines (sand and silt sized particles) that are already in the stream, usually below bankfull discharge elevation. Subsequent re-watering of the channel can result in a plume of turbidity and sedimentation.
- This technique washes the fines back into the channel bed. Bedload materials, including gravel cobbles, boulders and those fines, are naturally mobilized during higher storm flows. This technique is intended to delay the discharge until the fines would naturally be mobilized.

Appropriate Applications

- This technique should be used when construction work is required in channels. It is especially useful in intermittent or ephemeral streams in which work is performed “in the dry”, and which subsequently become re-watered.

Limitations

- The stream must have sufficient gravel and cobble substrate composition.
- The use of this technique requires consideration of time of year and timing of expected stream flows.
- The optimum time for the use of this technique is in the fall, prior to winter flows.
- Consultation with, and approval from the Department of Fish and Game and the Regional Water Quality Control Board may be required.

Implementation

- Apply sufficient water to wash fines, but not cause further erosion or runoff.
- Apply water slowly and evenly to prevent runoff and erosion.
- Consult with Department of Fish and Game and the Regional Water Quality Control Board for specific water quality requirements of applied water (e.g. chlorine).

Inspection and Maintenance

- None necessary

Costs

Cost may vary according to the combination of practices implemented.

Inspection and Maintenance

- Inspect and verify that activity-based BMPs are in place prior to the commencement of associated activities. While activities associated with the BMP are under way, inspect BMPs in accordance with General Permit requirements for the associated project type and risk level. It is recommended that at a minimum, BMPs be inspected weekly, prior to forecasted rain events, daily during extended rain events, and after the conclusion of rain events until final stabilization is achieved.
- Inspect BMPs subject to non-stormwater discharges daily while non-stormwater discharges occur.
- Inspect and repair equipment (for damaged hoses, fittings, and gaskets).

References

Manual of Standards of Erosion and Sediment Control Measures, Association of Bay Area Governments, May 1995.

Proposed Guidance Specifying Management Measures for Sources of Nonpoint Pollution in Coastal Waters, Work Group Working Paper, USEPA, April 1992.

Sedimentation and Erosion Control Practices, An Inventory of Current Practices (Draft), USEPA, 1990.

Stormwater Quality Handbooks Construction Site Best Management Practices (BMPs) Manual, State of California Department of Transportation (Caltrans), November 2000.

Stormwater Management for Construction Activities, Developing Pollution Prevention Plans and Best Management Practices, EPA 832-R-92005; USEPA, April 1992.

Water Quality Management Plan for the Lake Tahoe Region, Volume II, Handbook of Management Practices, Tahoe Regional Planning Agency, November 1988.

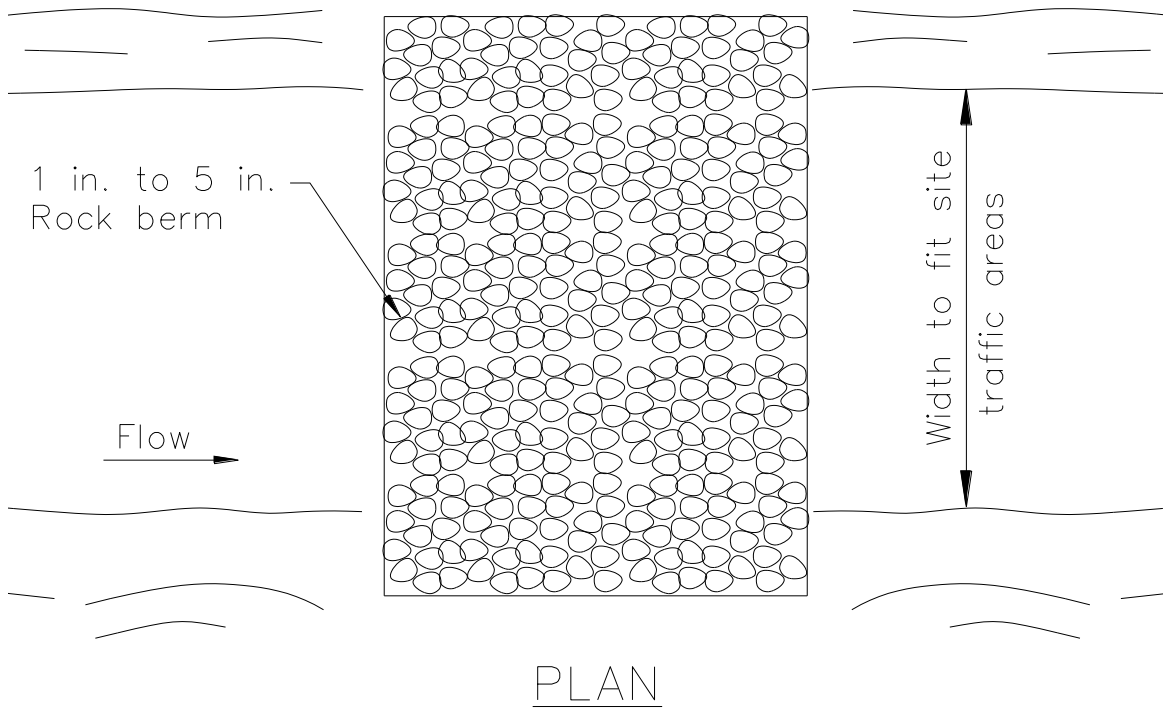
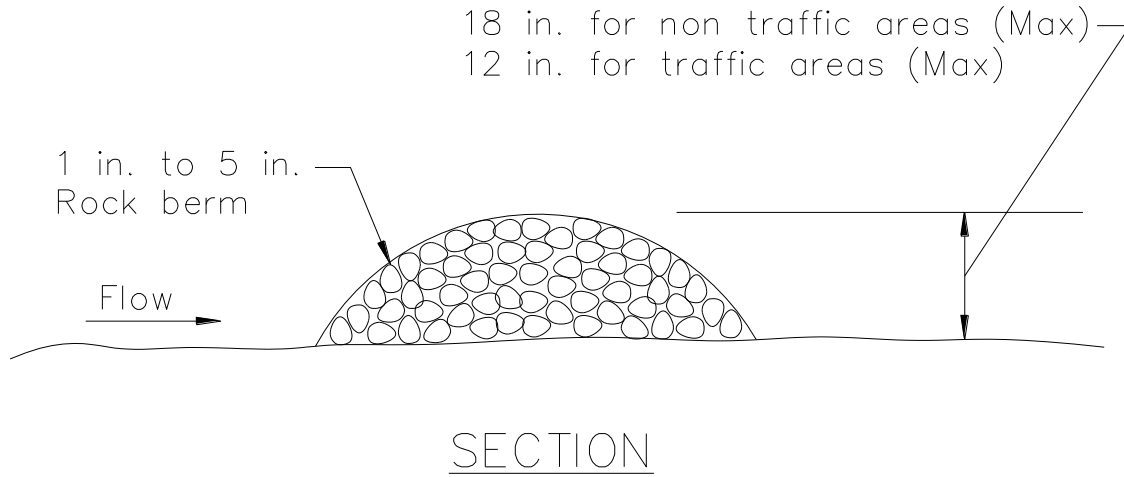

TYPICAL ROCK FILTER
NOT TO SCALE



Description and Purpose

A compost blanket is applied to slopes and earth disturbed areas to prevent erosion, and in some cases, increase infiltration and/or establish vegetation. The compost blanket can be applied by hand, conveyor system, compost spreader, or pneumatic delivery (blower) system. The blanket thickness is determined from the slope steepness and anticipated precipitation. A compost blanket protects the soil surface from raindrop erosion, particularly rills and gullies that may form under other methods of erosion control.

A compost blanket, if properly installed, can be very successful at vegetation establishment, weed suppression and erosion control. The compost blanket comes into direct contact with the underlying soil, reducing rill formation. Furthermore, compost provides organic matter and nutrients important for vegetation growth. The compost blanket provides soil structure that allows water to infiltrate the soil surface and retain moisture, which also promotes seed germination and vegetation growth, in addition to reducing runoff.

Compost is typically derived from combinations of feedstocks, biosolids, leaf and yard trimmings, manure, wood, or mixed solid waste. Many types of compost are products of municipal recycle or "Greenwaste" programs. Compost is organic and biodegradable and can be left onsite. There are many types of compost with a variety of properties with specific functions, and accordingly, compost selection is an important design consideration in the application of this type of erosion control.

Categories

EC	Erosion Control	<input checked="" type="checkbox"/>
SE	Sediment Control	<input type="checkbox"/>
TC	Tracking Control	<input type="checkbox"/>
WE	Wind Erosion Control	<input type="checkbox"/>
NS	Non-Stormwater Management Control	<input type="checkbox"/>
WM	Waste Management and Materials Pollution Control	<input type="checkbox"/>

Legend:

- Primary Category
- Secondary Category

Targeted Constituents

Sediment	<input checked="" type="checkbox"/>
Nutrients	<input type="checkbox"/>
Trash	<input type="checkbox"/>
Metals	<input type="checkbox"/>
Bacteria	<input type="checkbox"/>
Oil and Grease	<input type="checkbox"/>
Organics	<input type="checkbox"/>

Potential Alternatives

- EC-3 Hydraulic Mulch
- EC-4 Hydroseeding
- EC-5 Soil Binders
- EC-7 Geotextiles and Mats
- EC-8 Wood Mulching

If User/Subscriber modifies this fact sheet in any way, the CASQA name/logo and footer below must be removed from each page and not appear on the modified version.



Suitable Applications

A compost blanket is appropriate for slopes and earth disturbed areas requiring protection until permanent stabilization is established. A compost blanket can also be used in combination with temporary and/or permanent seeding strategies to enhance plant establishment. Examples include:

- Rough-graded areas that will remain inactive for longer than 14 days
- Soil stockpiles
- Slopes with exposed soil between existing vegetation such as trees or shrubs
- Slopes planted with live, container-grown vegetation
- Disturbed areas where plants are slow to develop

A compost blanket is typically used on slopes of 2:1 (H:V) or gentler. However, a compost blanket can be effective when applied to slopes as steep as 1:1 (H:V) with appropriate design considerations including slope length, blanket thickness, adding components such as a tackifier, or using compost blankets in conjunction with other techniques, such as compost socks and berms or fiber rolls.

Compost can be pre-seeded prior to application to the soil (recommended by the EPA for construction site stormwater runoff control) or seeded after the blanket has been installed. The compost medium can also remove pollutants in stormwater including heavy metals; oil and grease; and hydrocarbons (USEPA, 1998).

Limitations

- Compost can potentially leach nutrients (dissolved phosphorus and nitrogen) into runoff and potentially impact water quality. Compost should not be used directly upstream from nutrient impaired waterbodies (Adams et. al, 2008).
- Compost may also contain other undesirable constituents that are detrimental to water quality. Carefully consider the qualifications and experience of any compost producer/supplier.
- A compost blanket applied by hand is more time intensive and potentially costly. Using a pneumatic blower truck is the recommended cost effective method of application.
- When blowers are used, the treatment areas should be within 300 ft of a road or surface capable of supporting trucks.
- Wind may limit application of compost and result in application to undesired locations.
- Compost blankets should not be applied in areas of concentrated flows.
- Steeper slopes may require additional blanket thickness and other stability measures such as using tackifiers or slope interruption devices (compost socks and berms, or fiber rolls). The same applies for sites with high precipitation totals or during the rainy season.

Implementation

- Additional guidance on the comparison and selection of temporary slope stabilization methods is provided in Appendix F of the Handbook.

Compost Materials

- California Compost Regulations (Title 14, California Code of Regulations, Division 7, Chapter 3.1, Article 7, Section 17868.3) define and require a quality of compost for application. Compost should comply with all physical and chemical requirements. Specific requirements are provided in Table 1 below, taken from Caltrans Standard Special Provision 10-1 (SSP 10-1), Erosion Control (Compost Blanket).
- The compost producer should be fully permitted as specified under the California Integrated Waste Management Board, Local Enforcement Agencies and any other State and Local Agencies that regulate Solid Waste Facilities. If exempt from State permitting requirements, the composting facility should certify that it follows guidelines and procedures for production of compost meeting the environmental health standards of Title 14, California Code of Regulations, Division 7, Chapter 3.1, Article 7.
- The compost producer should be a participant in United States Composting Council's Seal of Testing Assurance program.
- Compost moisture should be considered for composition quality and application purposes. A range of 30-50% is typical. Compost that is too dry is hard to apply and compost that is too wet is more difficult (and more expensive) to transport. For arid or semi-arid areas, or for application during the dry season, use compost with greater moisture content than areas with wetter climates. For wetter or more humid climates or for application during the wet season, drier composts can be used as the compost will absorb moisture from the ambient air.
- Organic content of the compost is also important and should range from 30 to 65% depending on site conditions.
- Compost should be high-quality mature compost. Immature compost can potentially leach nutrients.
- Compost should not be derived from mixed municipal solid waste and should be free of visible contaminants.
- Compost should not contain paint, petroleum products, pesticides or any other chemical residues harmful to animal life or plant growth. Metal concentrations in compost should not exceed the maximum metal concentrations listed under Title 14, California Code of Regulations, Division 7, Chapter 3.1, Section 17868.2.
- Compost should not possess objectionable odors.
- Compost should be weed free.

Table 1. Physical/Chemical Requirements of Compost
Reference - Caltrans SSP-10 Erosion Control Blanket (Compost)

Property	Test Method	Requirement
pH	*TMECC 04.11-A Elastometric pH 1:5 Slurry Method pH Units	6.0–8.0
Soluble Salts	TMECC 04.10-A Electrical Conductivity 1:5 Slurry Method dS/m (mmhos/cm)	0-10.0
Moisture Content	TMECC 03.09-A Total Solids & Moisture at 70+/- 5 deg C % Wet Weight Basis	30-60
Organic Matter Content	TMECC 05.07-A Loss-On-Ignition Organic Matter Method (LOI) % Dry Weight Basis	30–65
Maturity	TMECC 05.05-A Germination and Vigor Seed Emergence Seedling Vigor % Relative to Positive Control	80 or Above 80 or Above
Stability	TMECC 05.08-B Carbon Dioxide Evolution Rate mg CO ₂ -C/g OM per day	8 or below
Particle Size	TMECC 02.02-B Sample Sieving for Aggregate Size Classification % Dry Weight Basis	100% Passing, 3 inch 90-100% Passing, 1 inch 65-100% Passing, 3/4 inch 0 - 75% Passing, 1/4 inch Maximum length 6 inches
Pathogen	TMECC 07.01-B Fecal Coliform Bacteria < 1000 MPN/gram dry wt.	Pass
Pathogen	TMECC 07.01-B Salmonella < 3 MPN/4 grams dry wt.	Pass
Physical Contaminants	TMECC 02.02-C Man Made Inert Removal and Classification: Plastic, Glass and Metal % > 4mm fraction	Combined Total: < 1.0
Physical Contaminants	TMECC 02.02-C Man Made Inert Removal and Classification: Sharps (Sewing needles, straight pins and hypodermic needles) % > 4mm fraction	None Detected

*TMECC refers to "Test Methods for the Examination of Composting and Compost," published by the United States Department of Agriculture and the United States Compost Council (USCC).

Installation

- Prior to compost application, prepare the slope by removing loose rocks, roots, stumps, and other debris greater than 2” in diameter. Prepare the slope area surface by scarifying or track walking/roughening if necessary.
- Select method to apply the compost blanket. A pneumatic blower is most cost effective and most adaptive in applying compost to steep, rough terrain, and hard to reach locations.
- A compost blanket thickness of 1” to 4” should be applied to slopes of 2:1 (H:V) or gentler, based on site-specific conditions. Increase blanket thickness with increased slope steepness and/or during installation during the rainy season (for example, 2” to 3” should be used for a

3:1 slope, while 1" to 2" can be used for a 4:1 slope). Erosion control using a compost blanket is not recommended for slopes greater than 1:1 (H:V).

- For steeper slopes, tackifiers should be utilized and/or other stabilization techniques employed. For example, compost socks or berms can be installed at intervals over the compost blanket (in a similar manner as Fiber Rolls, SE-5).
- Compost socks or berms (or equivalent linear sediment control BMP) should be placed at the top and/or bottom of the slope for additional erosion control performance.
- For optimum vegetation establishment, a blanket thickness of 1" to 2" is recommended. If vegetation establishment is not the primary function of the compost blanket, a thicker blanket may be recommended based on slope or rainfall conditions.
- Evenly distribute compost on the soil surface to the desired blanket thickness (1/2" to 4" as calculated prior based on site conditions and objectives). Even distribution is an important factor in preventing future rill and gully erosion.
- The compost blanket should extend 3 to 6 feet over the top of the shoulder of the slope. A compost sock or compost berm can be used at the top of the slope as an auxiliary technique to prevent runoff from flowing underneath the compost blanket.
- Use additional anchoring and erosion control BMPs in conjunction of the compost blanket as needed.

Costs

The cost associated with a compost blanket is similar to that of a straw mat and generally less expensive than a geotextile blanket (USEPA, 2009). Caltrans has provided a recent estimate for \$5,000 to \$8,000 per acre for application of an unseeded 1 inch compost blanket (Caltrans Compost Specifications, 2009). Recently obtained vendor costs indicate that proprietary blends of compost that are seeded and contain a nutrient rich "tackifier" can cost approximately \$0.35 per square foot, or approximately \$15,000 per acre for a 2 inch blanket. Application by hand is more time intensive and likely more costly.

Inspection and Maintenance

- BMPs must be inspected in accordance with General Permit requirements for the associated project type and risk level. It is recommended that at a minimum, BMPs be inspected weekly, prior to forecasted rain events, daily during extended rain events, and after the conclusion of rain events.
- Areas where erosion is evident, another layer of compost should be reapplied as soon as possible. It may be necessary to install an additional type of stormwater BMP at the top of slope or as a slope interrupter to control flow, such as a fiber roll (SE-5) or compost sock (SE-11).
- Care should be exercised to minimize the damage to protected areas while making repairs, as any area damaged will require reapplication of BMPs.
- Limit or prohibit foot traffic to minimize damage to BMP or impede vegetation establishment.

References

An Analysis of Composting as an Environmental Remediation Technology, U.S. Environmental Protection Agency (USEPA), Solid Waste and Emergency Response (5305W), EPA530-R-8-008, 1998.

Characteristics of Compost: Moisture Holding and Water Quality Improvement, Center for Research in Water Resources, Kirchoff, C., Malina, J., and Barrett, M., 2003.

Compost Utilization for Erosion Control, The University of Georgia College of Agricultural and Environmental Sciences, pubs.caes.uga.edu/caespubs/pubcd/B1200.htm, Faucette, B. and Risse, M., 2009.

Demonstration Project Using Yard Debris Compost for Erosion Control, Final Report, presented to Metropolitan Service District, W&H Pacific, 1993.

Erosion and Sediment Control Manual, Oregon Department of Environmental Quality, 2005.

Standard Special Provision 10-1, Erosion Control (Compost Blanket), California Department of Transportation (Caltrans). 2007 Update.

Evaluation of Environmental Benefits and Impacts of Compost and Industry Standard Erosion and Sediment Controls Measures Used in Construction Activities, Dissertation, Institute of Ecology, University of Georgia, Faucette, B., 2004.

Filter Sock Presentation provided at Erosion, Sediment Control and Stormwater Management with Compost BMPs Workshop, U.S. Composting Council 13th Annual Conference and Trade Show, McCoy, S., 2005.

National Pollutant Discharge Elimination System (NPDES), Compost Blankets, U.S. Environmental Protection Agency (USEPA).
http://cfpub.epa.gov/npdes/stormwater/menuofbmps/index.cfm?action=factsheet_results&view=specific&bmp=118, 2009.

Standard Specifications for Transportation Materials and Methods of Sampling and Testing Designation M10-03, Compost for Erosion/Sediment Control (Compost Blankets), Provisional, American Association of State Highway Transportation Officials (AASHTO), 2003.

Stormwater Best Management Practices (BMPs) Field Trials of Erosion Control Compost in Reclamation of Rock Quarry Operations, Nonpoint Source Protection Program CWA §319(h), Texas Commission on Environmental Quality, Adams, T., McFarland, A., Hauck, L., Barrett, M., and Eck, B., 2008.



Description and Purpose

Soil Preparation/Roughening involves assessment and preparation of surface soils for BMP installation. This can include soil testing (for seed base, soil characteristics, or nutrients), as well as roughening surface soils by mechanical methods (including sheepsfoot rolling, track walking, scarifying, stair stepping, and imprinting) to prepare soil for additional BMPs, or to break up sheet flow. Soil Preparation can also involve tilling topsoil to prepare a seed bed and/or incorporation of soil amendments, to enhance vegetative establishment.

Suitable Applications

Soil preparation: Soil preparation is essential to proper vegetative establishment. In particular, soil preparation (i.e. tilling, raking, and amendment) is suitable for use in combination with any soil stabilization method, including RECPs or sod. Soil preparation should not be confused with roughening.

Roughening: Soil roughening is generally referred to as track walking (sometimes called imprinting) a slope, where treads from heavy equipment run parallel to the contours of the slope and act as mini terraces. Soil preparation is most effective when used in combination with erosion controls. Soil Roughening is suitable for use as a complementary process for controlling erosion on a site. Roughening is not intended to be used as a stand-alone BMP, and should be used with perimeter controls, additional erosion control measures, grade breaks, and vegetative establishment for maximum effectiveness. Roughening is intended to only affect surface soils and should not compromise slope stability or overall compaction. Suitable applications for soil roughening include:

Categories

EC	Erosion Control	<input checked="" type="checkbox"/>
SE	Sediment Control	<input checked="" type="checkbox"/>
TC	Tracking Control	
WE	Wind Erosion Control	
NS	Non-Stormwater Management Control	
WM	Waste Management and Materials Pollution Control	

Legend:

- Primary Category
- Secondary Category

Targeted Constituents

Sediment	<input checked="" type="checkbox"/>
Nutrients	
Trash	
Metals	
Bacteria	
Oil and Grease	
Organics	

Potential Alternatives

- EC-3 Hydraulic Mulch
- EC-5 Soil Binders
- EC-7 Geotextiles and Mats

If User/Subscriber modifies this fact sheet in any way, the CASQA name/logo and footer below must be removed from each page and not appear on the modified version.



- Along any disturbed slopes, including temporary stockpiles, sediment basins, or compacted soil diversion berms and swales.
- Roughening should be used in combination with hydraulically applied stabilization methods, compost blanket, or straw mulch; but should not be used in combination with RECPs or sod because roughening is intended to leave terraces on the slope.

Limitations

- Preparation and roughening must take place prior to installing other erosion controls (such as hydraulically applied stabilizers) or sediment controls (such as fiber rolls) on the faces of slopes.
- In such cases where slope preparation is minimal, erosion control/revegetation BMPs that do not require extensive soil preparation - such as hydraulic mulching and seeding applications - should be employed.
- Consideration should be given to the type of erosion control BMP that follows surface preparation, as some BMPs are not designed to be installed over various types of tillage/roughening, i.e., RECPs (erosion control blankets) should not be used with soil roughening due to a “bridging” effect, which suspends the blanket above the seed bed.
- Surface roughness has an effect on the amount of mulch material that needs to be applied, which shows up as a general increase in mulch material due to an increase in surface area (Topographic Index -see EC-3 Hydraulic Mulching).

Implementation

- Additional guidance on the comparison and selection of temporary slope stabilization methods is provided in Appendix F of the Handbook.

General

A roughened surface can significantly reduce erosion. Based on tests done at the San Diego State Erosion Research Laboratory, various roughening techniques on slopes can result in a 12 - 76% reduction in the erosion rate versus smooth slopes.

Materials

Minimal materials are required unless amendments and/or seed are added to the soil. The majority of soil roughening/preparation can be done with equipment that is on hand at a normal construction site, such as bull dozers and compaction equipment.

Installation Guidelines

Soil Preparation

- Where appropriate or feasible, soil should be prepared to receive the seed by disking or otherwise scarifying the surface to eliminate crust, improve air and water infiltration and create a more favorable environment for germination and growth.
- Based upon soil testing conducted, apply additional soil amendments (e.g. fertilizers, additional seed) to the soil to help with germination. Follow EC-4, Hydroseeding, when selecting and applying seed and fertilizers.

Cut Slope Roughening:

- Stair-step grade or groove the cut slopes that are steeper than 3:1.
- Use stair-step grading on any erodible material soft enough to be ripped with a bulldozer. Slopes consisting of soft rock with some subsoil are particularly suited to stair-step grading.
- Make the vertical cut distance less than the horizontal distance, and slightly slope the horizontal position of the "step" in toward the vertical wall.
- Do not make individual vertical cuts more than 2 feet (0.6 m) high in soft materials or more than 3 feet (0.9 m) high in rocky materials.
- Groove the slope using machinery to create a series of ridges and depressions that run across the slope, on the contour.

Fill Slope Roughening:

- Place on fill slopes with a gradient steeper than 3:1 in lifts not to exceed 8 inches (0.2 m), and make sure each lift is properly compacted.
- Ensure that the face of the slope consists of loose, uncompacted fill 4-6 inches (0.1-0.2 m) deep.
- Use grooving or tracking to roughen the face of the slopes, if necessary.
- Do not blade or scrape the final slope face.

Roughening for Slopes to be Mowed:

- Slopes which require mowing activities should not be steeper than 3:1.
- Roughen these areas to shallow grooves by track walking, scarifying, sheepsfoot rolling, or imprinting.
- Make grooves close together (less than 10 inches), and not less than 1 inch deep, and perpendicular to the direction of runoff (i.e., parallel to the slope contours).
- Excessive roughness is undesirable where mowing is planned.

Roughening With Tracked Machinery:

- Limit roughening with tracked machinery to soils with a sandy textural component to avoid undue compaction of the soil surface.
- Operate tracked machinery up and down the slope to leave horizontal depressions in the soil. Do not back-blade during the final grading operation.
- Seed and mulch roughened areas as soon as possible to obtain optimum seed germination and growth.

Costs

Costs are based on the additional labor of tracking or preparation of the slope plus the cost of any required soil amendment materials.

Inspection and Maintenance

- BMPs must be inspected in accordance with General Permit requirements for the associated project type and risk level. It is recommended that at a minimum, BMPs be inspected weekly, prior to forecasted rain events, daily during extended rain events, and after the conclusion of rain events.
- Check the seeded slopes for signs of erosion such as rills and gullies. Fill these areas slightly above the original grade, then reseed and mulch as soon as possible.
- Inspect BMPs weekly during normal operations, prior to forecasted rain events, daily during extended rain events, and after the conclusion of rain events.

References

Soil Stabilization BMP Research for Erosion and Sediment Controls: Cost Survey Technical Memorandum, State of California Department of Transportation (Caltrans), July 2007.

Erosion and Sediment Control Manual, Oregon Department of Environmental Quality, February 2005.



Description and Purpose

Non-vegetative stabilization methods are used for temporary or permanent stabilization of areas prone to erosion and should be used only where vegetative options are not feasible; examples include:

- Areas of vehicular or pedestrian traffic such as roads or paths;
- Arid environments where vegetation would not provide timely ground coverage, or would require excessive irrigation;
- Rocky substrate, infertile or droughty soils where vegetation would be difficult to establish; and
- Areas where vegetation will not grow adequately within the construction time frame.

There are several non-vegetative stabilization methods and selection should be based on site-specific conditions.

Decomposed Granite (DG) is a permanent erosion protection method that consists of a layer of stabilized decomposed granite placed over an erodible surface.

Degradable Mulches of various types (see EC-3, EC-6, EC-8) can be used for temporary non-vegetative stabilization; examples include straw mulch, compost, wood chips or hydraulic mulch.

Geotextiles and Mats can be used for temporary non-vegetative stabilization (see EC-7). These BMPs are typically manufactured from degradable or synthetic materials and are

Categories

EC	Erosion Control	<input checked="" type="checkbox"/>
SE	Sediment Control	<input checked="" type="checkbox"/>
TR	Tracking Control	
WE	Wind Erosion Control	<input checked="" type="checkbox"/>
NS	Non-Stormwater Management Control	
WM	Waste Management and Materials Pollution Control	

Legend:

- Primary Category
- Secondary Category

Targeted Constituents

Sediment	<input checked="" type="checkbox"/>
Nutrients	
Trash	
Metals	
Bacteria	
Oil and Grease	
Organics	

Potential Alternatives

None

If User/Subscriber modifies this fact sheet in any way, the CASQA name/logo and footer below must be removed from each page and not appear on the modified version.



designed and specified based on their functional longevity, i.e., how long they will persist and provide erosion protection. All geotextiles and mats should be replaced when they exceed their functional longevity or when permanent stabilization methods are instituted.

Gravel Mulch is a non-degradable erosion control product that is composed of washed and screened coarse to very coarse gravel, 16 mm to 64 mm (0.6" - 2.5"), similar to an AASHTO No. 3 coarse aggregate.

Rock Slope Protection consists of utilizing large rock or rip-rap (4" - 24") to stabilize slopes with a high erosion potential and those subject to scour along waterways.

Soil Binders can be used for temporary non-vegetative stabilization (see EC-5). The key to their use is functional longevity. In most cases, the soil binder will need to be routinely monitored and re-applied to maintain an erosion-resistant coverage.

Suitable Applications

Non-vegetated stabilization methods are suitable for use on disturbed soil areas and on material stockpiles that need to be temporarily or permanently protected from erosion by water and wind. Non-vegetated stabilization should only be utilized when vegetation cannot be established in the required timeframe, due to soil or climactic conditions, or where vegetation may be a potential fire hazard.

Decomposed Granite (DG) and Gravel Mulch are suitable for use in areas where vegetation establishment is difficult, on flat surfaces, trails and pathways, and when used in conjunction with a stabilizer or tackifier, on shallow slopes (i.e., 10:1 [H:V]). DG and gravel can also be used on shallow rocky slopes where vegetation cannot be established for permanent erosion control.

Degradable Mulches can be used to cover and protect soil surfaces from erosion both in temporary and permanent applications. In many cases, the use of mulches by themselves requires routine inspection and re-application. See EC-3 Hydraulic Mulch, EC-6 Straw Mulch, EC-8 Wood Mulch, or EC-14 Compost Blankets for more information.

Geotextiles and Mats can be used as a temporary stand-alone soil stabilization method. Depending on material selection, geotextiles and mats can be a short-term (3 mos – 1 year) or long-term (1-2 years) temporary stabilization method. For more information on geotextiles and mats see EC-7 Geotextiles and Mats.

Rock Slope Protection can be used when the slopes are subject to scour or have a high erosion potential, such as slopes adjacent to flowing waterways or slopes subject to overflow from detention facilities (spillways).

Soil Binders can be used for temporary stabilization of stockpiles and disturbed areas not subject to heavy traffic. See EC-5 Soil Binders for more information.

Limitations

General

- Refer to EC-3, EC-6, EC-8, and EC-14 for limitations on use of mulches. Refer to EC-7 for limitations on use of geotextiles and mats. Refer to EC-5 for limitations on use of Soil Binders.

Decomposed Granite

- Not available in some geographic regions.
- If not tackified, material may be susceptible to erosion even on slight slopes (e.g., 30:1 [H:V]).
- Installed costs may be more expensive than vegetative stabilization methods.

Gravel Mulch

- Availability is limited in some geographic regions.
- If not properly screened and washed, can contain fine material that can erode and/or create dust problems.
- If inadequately sized, material may be susceptible to erosion on sloped areas.
- Pore spaces fill with dirt and debris over time; may provide a growing medium for weeds.

Rock Slope Protection

- Installation is labor intensive.
- Installed costs can be significantly higher than vegetative stabilization methods.
- Rounded stones may not be used on slopes greater than 2:1 [H:V].

Implementation

General

Non-vegetated stabilization should be used in accordance with the following general guidance:

- Should be used in conjunction with other BMPs, including drainage, erosion controls and sediment controls.
- Refer to EC-3, EC-6, EC-8, and EC-14 for implementation details for mulches. Refer to EC-7 for implementation details for geotextiles and mats. Refer to EC-5 for implementation details for soil binders.
- Non-vegetated stabilization measures should be implemented as soon as the disturbance in the areas they are intended to protect has ceased.
- Additional guidance on the comparison and selection of temporary slope stabilization methods is provided in Appendix F of the Handbook.

Decomposed Granite Stabilization

- If used for a road or path should be installed on a prepared base.
- Should be mixed with a stabilizer if used for roads or pathways, or on slope applications.
- Though porous it is recommended to prevent standing water on or next to a decomposed granite road or pathway.

Gravel Mulch

- Should be sized based on slope, rainfall, and upgradient run-on conditions. Stone size should be increased as potential for erosion increases (steeper slopes, high intensity rainfall).
- If permanent, a weed control fabric should be placed prior to installation.
- Should be installed at a minimum 2" depth.
- Should completely cover all exposed surfaces.

Rock Slope Protection

- Rock slope protection installation should follow Caltrans Standard Specification 72-2: Rock Slope Protection. Refer to the specification for rock conformity requirements and installation methods.
- When using rock slope protection, rock size and installation method should be specified by an Engineer.
- A geotextile fabric should be placed prior to installation.

Costs

- Costs are highly variable depending not only on technique chosen, but also on materials chosen within specific techniques. In addition, availability of certain materials will vary by region/location, which will also affect the cost. Costs of mulches, geotextiles and mats, and soil binders are presented in their respective fact sheets. Costs for decomposed granite, gravel mulch stabilization and rock slope protection may be higher depending on location and availability of materials. Caltrans has provided an estimate for gravel mulch of \$10 - \$15/yd² in flat areas and \$11 - \$23/yd² on side slopes.

Inspection and Maintenance

General

- BMPs must be inspected in accordance with General Permit requirements for the associated project type and risk level. It is recommended that at a minimum, BMPs be inspected weekly, prior to forecasted rain events, daily during extended rain events, and after the conclusion of rain events.
- For permanent installation, require inspection periodically and after major storm events to look for signs of erosion or damage to the stabilization.
- All damage should be repaired immediately.
- Refer to EC-3, EC-6, EC-8, and EC-14 for inspection and maintenance requirements for mulches. Refer to EC-7 for inspection and maintenance requirements for geotextiles and mats. Refer to EC-5 for inspection and maintenance requirements for soil binders.

Decomposed Granite and Gravel Mulch Stabilization

- Rake out and add decomposed granite or gravel as needed to areas subject to rill erosion. Inspect upgradient drainage controls and repair/modify as necessary.

- Should remain stable under loose surface material. Any significant problem areas should be repaired to restore uniformity to the installation.

References

Arid Zone Forestry: A Guide for Field Technicians. Food and Agriculture Organization of the United Nations, 1989.

Design of Roadside Channels with Flexible Linings, Hydraulic Engineering Circular Number 15, Third Edition, Federal Highway Administration, 2007.

Design Standards for Urban Infrastructure - Soft Landscape Design, Department of Territory and Municipal Services - Australian Capital Territory http://www.tams.act.gov.au/work/standards_and_procedures/design_standards_for_urban_infrastructure

Erosion and Sediment Control Handbook: A Guide for Protection of State Waters through the use of Best Management Practices during Land Disturbing Activities, Tennessee Department of Environment and Conservation, 2002.

Gravel Mulch, Landscape Architecture Non-Standard Specification 10-2, California Department of Transportation (Caltrans), <http://www.dot.ca.gov/hq/LandArch/roadside/detail-gm.htm>

Maine Erosion and Sediment Control BMPs, DEPLW0588, Maine Department of Environmental Protection: Bureau of Land and Water Quality, 2003.

National Menu of Best Management Practices, US Environmental Protection Agency, 2006.

Standard Specification 72-2: Rock Slope Protection. California Department of Transportation, 2006.

Stormwater Quality Handbooks Construction Site Best Management Practices (BMPs) Manual, State of California Department of Transportation (Caltrans), March 2003.

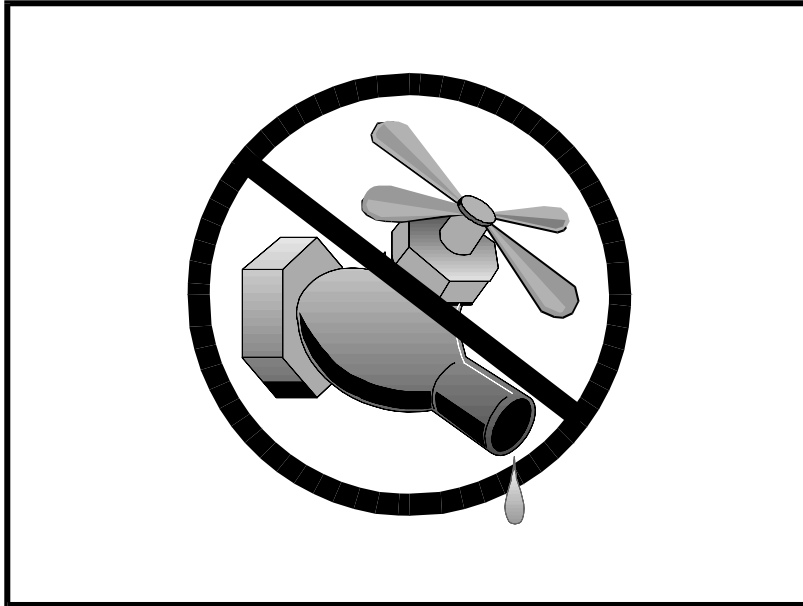

Description and Purpose

Water conservation practices are activities that use water during the construction of a project in a manner that avoids causing erosion and the transport of pollutants offsite. These practices can reduce or eliminate non-stormwater discharges.

Suitable Applications

Water conservation practices are suitable for all construction sites where water is used, including piped water, metered water, trucked water, and water from a reservoir.

Limitations

- None identified.

Implementation

- Keep water equipment in good working condition.
- Stabilize water truck filling area.
- Repair water leaks promptly.
- Washing of vehicles and equipment on the construction site is discouraged.
- Avoid using water to clean construction areas. If water must be used for cleaning or surface preparation, surface should be swept and vacuumed first to remove dirt. This will minimize amount of water required.

Categories

EC	Erosion Control	<input checked="" type="checkbox"/>
SE	Sediment Control	<input checked="" type="checkbox"/>
TC	Tracking Control	
WE	Wind Erosion Control	
NS	Non-Stormwater Management Control	<input checked="" type="checkbox"/>
WM	Waste Management and Materials Pollution Control	

Legend:

- Primary Objective
- Secondary Objective

Targeted Constituents

Sediment	<input checked="" type="checkbox"/>
Nutrients	
Trash	
Metals	
Bacteria	
Oil and Grease	
Organics	

Potential Alternatives

None

If User/Subscriber modifies this fact sheet in any way, the CASQA name/logo and footer below must be removed from each page and not appear on the modified version.



- Direct construction water runoff to areas where it can soak into the ground or be collected and reused.
- Authorized non-stormwater discharges to the storm drain system, channels, or receiving waters are acceptable with the implementation of appropriate BMPs.
- Lock water tank valves to prevent unauthorized use.

Costs

The cost is small to none compared to the benefits of conserving water.

Inspection and Maintenance

- Inspect and verify that activity based BMPs are in place prior to the commencement of authorized non-stormwater discharges.
- Inspect BMPs in accordance with General Permit requirements for the associated project type and risk level. It is recommended that at a minimum, BMPs be inspected weekly, prior to forecasted rain events, daily during extended rain events, and after the conclusion of rain events.
- Inspect BMPs subject to non-stormwater discharges daily while non-stormwater discharges are occurring.
- Repair water equipment as needed to prevent unintended discharges.
 - Water trucks
 - Water reservoirs (water buffalos)
 - Irrigation systems
 - Hydrant connections

References

Stormwater Quality Handbooks - Construction Site Best Management Practices (BMPs) Manual, State of California Department of Transportation (Caltrans), November 2000.

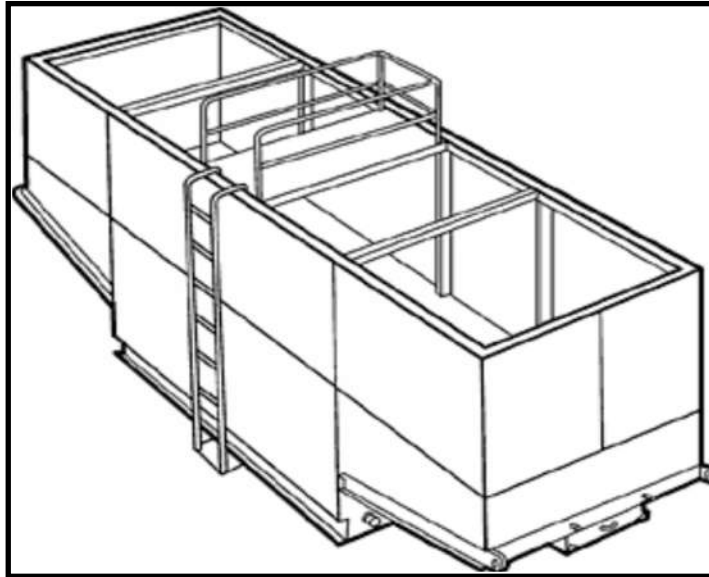

Description and Purpose

Dewatering operations are practices that manage the discharge of pollutants when non-stormwater and accumulated precipitation (stormwater) must be removed from a work location to proceed with construction work or to provide vector control.

The General Permit incorporates Numeric Action Levels (NAL) for turbidity (see Section 2 of this handbook to determine your project's risk level and if you are subject to these requirements).

Discharges from dewatering operations can contain high levels of fine sediment that, if not properly treated, could lead to exceedances of the General Permit requirements or Basin Plan standards.

The dewatering operations described in this fact sheet are not Active Treatment Systems (ATS) and do not include the use of chemical coagulations, chemical flocculation or electrocoagulation.

Suitable Applications

These practices are implemented for discharges of non-stormwater from construction sites. Non-stormwaters include, but are not limited to, groundwater, water from cofferdams, water diversions, and waters used during construction activities that must be removed from a work area to facilitate construction.

Practices identified in this section are also appropriate for implementation when managing the removal of accumulated

Categories

EC	Erosion Control	
SE	Sediment Control	<input checked="" type="checkbox"/>
TC	Tracking Control	
WE	Wind Erosion Control	
NS	Non-Stormwater Management Control	<input checked="" type="checkbox"/>
WM	Waste Management and Materials Pollution Control	

Legend:

- Primary Category
- Secondary Category

Targeted Constituents

Sediment	<input checked="" type="checkbox"/>
Nutrients	
Trash	
Metals	
Bacteria	
Oil and Grease	<input checked="" type="checkbox"/>
Organics	

Potential Alternatives

- SE-5: Fiber Roll
- SE-6: Gravel Bag Berm

If User/Subscriber modifies this fact sheet in any way, the CASQA name/logo and footer below must be removed from each page and not appear on the modified version.



precipitation (stormwater) from depressed areas at a construction site.

Stormwater mixed with non-stormwater should be managed as non-stormwater.

Limitations

- Dewatering operations will require, and should comply with applicable local and project-specific permits and regulations. In some areas, all dewatering activities, regardless of the discharge volume, require a dewatering permit.
- Site conditions will dictate design and use of dewatering operations.
- The controls discussed in this fact sheet primarily address sediment. Other secondary pollutant removal benefits are discussed where applicable.
- The controls detailed in this fact sheet only allow for minimal settling time for sediment particles. Use only when site conditions restrict the use of the other control methods.
- Avoid dewatering discharges where possible by using the water for dust control.

Implementation

- A Construction Site Monitoring Plan (CSMP) should be included in the project Stormwater Pollution Prevention Plan (SWPPP).
- Regional Water Quality Control Board (RWQCB) Regions may require notification and approval prior to any discharge of water from construction sites.
- The destination of discharge from dewatering activities will typically determine the type of permit required for the discharge. For example, when discharging to a water of the U.S., a dewatering permit may be required through the site's governing RWQCB. When discharging to a sanitary sewer or Municipal Separate Storm Sewer System (MS4), a permit may need to be obtained from the owner of the sanitary sewer or MS4 in addition to obtaining an RWQCB dewatering permit. Additional permits or permissions from other agencies may be required for dewatering cofferdams or diversions.
- Dewatering discharges should not cause erosion at the discharge point. Appropriate BMPs should be implemented to maintain compliance with all applicable permits.
- Maintain dewatering records in accordance with all local and project-specific permits and regulations.

Sediment Treatment

A variety of methods can be used to treat water during dewatering operations. Several devices are presented below and provide options to achieve sediment removal. The sediment particle size and permit or receiving water limitations on sediment or turbidity are key considerations for selecting sediment treatment option(s); in some cases, the use of multiple devices may be appropriate. Use of other enhanced treatment methods (i.e., introduction of chemicals or electric current to enhance flocculation and removal of sediment) must comply with: 1) for storm drain or surface water discharges, the requirements for Active Treatment Systems (see SE-11); or 2) for sanitary sewer discharges, the requirements of applicable sanitary sewer discharge permits.

Sediment Basin (see also SE-2)

Description:

- A sediment basin is a temporary basin with a controlled release structure that is formed by excavation or construction of an embankment to detain sediment-laden runoff and allow sediment to settle out before discharging. Sediment basins are generally larger than Sediment Traps (SE-3) and have a designed outlet structure.

Appropriate Applications:

- Effective for the removal of trash, gravel, sand, silt, some metals that settle out with the sediment.

Implementation:

- Excavation and construction of related facilities is required.
- Temporary sediment basins should be fenced if safety is a concern.
- Outlet protection is required to prevent erosion at the outfall location.

Maintenance:

- Maintenance is required for safety fencing, vegetation, embankment, inlet and outlet, as well as other features.
- Removal of sediment is required when the storage volume is reduced by one-third.

Sediment Trap (See also SE-3)

Description:

- A sediment trap is a temporary basin formed by excavation and/or construction of an earthen embankment across a waterway or low drainage area to detain sediment-laden runoff and allow sediment to settle out before discharging. Sediment traps are generally smaller than Sediment Basins (SE-2) and do not have a designed outlet (but do have a spillway or overflow).

Appropriate Applications:

Effective for the removal of large and medium sized particles (sand and gravel) and some metals that settle out with the sediment.

Implementation:

- Excavation and construction of related facilities is required.
- Trap inlets should be located to maximize the travel distance to the trap outlet.
- Use rock or vegetation to protect the trap outlets against erosion.

Maintenance:

- Maintenance is required for vegetation, embankment, inlet and outfall structures, as well as other features.
- Removal of sediment is required when the storage volume is reduced by one-third.

Weir Tanks

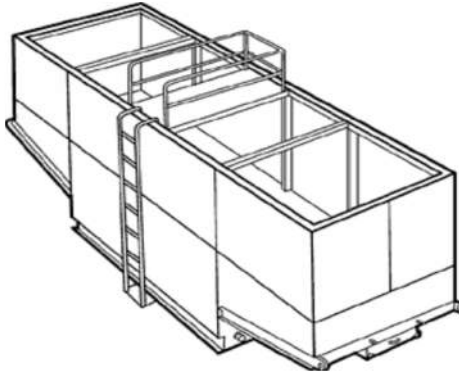

Description:

- A weir tank separates water and waste by using weirs. The configuration of the weirs (over and under weirs) maximizes the residence time in the tank and determines the waste to be removed from the water, such as oil, grease, and sediments.

Appropriate Applications:

- The tank removes trash, some settleable solids (gravel, sand, and silt), some visible oil and grease, and some metals (removed with sediment). To achieve high levels of flow, multiple tanks can be used in parallel. If additional treatment is desired, the tanks can be placed in series or as pre-treatment for other methods.

Implementation:

- Tanks are delivered to the site by the vendor, who can provide assistance with set-up and operation.
- Tank size will depend on flow volume, constituents of concern, and residency period required. Vendors should be consulted to appropriately size tank.
- Treatment capacity (i.e., volume and number of tanks) should provide at a minimum the required volume for discrete particle settling for treatment design flows.

Maintenance:

- Periodic cleaning is required based on visual inspection or reduced flow.
- Oil and grease disposal should be conducted by a licensed waste disposal company.

Dewatering Tanks



Description:

- A dewatering tank removes debris and sediment. Flow enters the tank through the top, passes through a fabric filter, and is discharged through the bottom of the tank. The filter separates the solids from the liquids.

Appropriate Applications:

- The tank removes trash, gravel, sand, and silt, some visible oil and grease, and some metals (removed with sediment). To achieve high levels of flow, multiple tanks can be used in parallel. If additional treatment is desired, the tanks can be placed in series or as pre-treatment for other methods.

Implementation:

- Tanks are delivered to the site by the vendor, who can provide assistance with set-up and operation.
- Tank size will depend on flow volume, constituents of concern, and residency period required. Vendors should be consulted to appropriately size tank.

Maintenance:

- Periodic cleaning is required based on visual inspection or reduced flow.
- Oil and grease disposal should be conducted by licensed waste disposal company.

Gravity Bag Filter

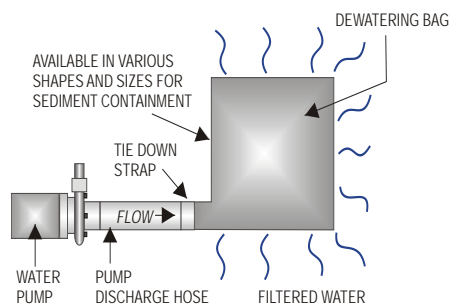

Description:

- A gravity bag filter, also referred to as a dewatering bag, is a square or rectangular bag made of non-woven geotextile fabric that collects gravel, sand, silt, and fines.

Appropriate Applications:

- Effective for the removal of sediments (gravel, sand, silt, and fines). Some metals are removed with the sediment.

Implementation:

- Water is pumped into one side of the bag and seeps through the top, bottom, and sides of the bag.
- Place filter bag on pavement or a gravel bed or paved surface. Avoid placing a dewatering bag on unprotected bare soil. If placing the bag on bare soil is unavoidable, a secondary barrier should be used, such as a rock filter bed placed beneath and beyond the edges of the bag to, prevent erosion and capture sediments that escape the bag.
- Perimeter control around the downstream end of the bag should be implemented. Secondary sediment controls are important especially in the initial stages of discharge, which tend to allow fines to pass through the bag.

Maintenance:

- Inspection of the flow conditions, bag condition, bag capacity, and the secondary barrier (as applicable) is required.
- Replace the bag when it no longer filters sediment or passes water at a reasonable rate.
- Caution should be taken when removing and disposing of the bag, to prevent the release of captured sediment
- Properly dispose of the bag offsite. If sediment is removed from the bag prior to disposal (bags can potentially be reused depending upon their condition), dispose of sediment in accordance with the general maintenance procedures described at the end of this BMP Fact Sheet.

Sand Media Particulate Filter



Description:

- Water is treated by passing it through canisters filled with sand media. Generally, sand filters provide a final level of treatment. They are often used as a secondary or higher level of treatment after a significant amount of sediment and other pollutants have been removed using other methods.

Appropriate Applications:

- Effective for the removal of trash, gravel, sand, and silt and some metals, as well as the reduction of biochemical oxygen demand (BOD) and turbidity.
- Sand filters can be used for stand-alone treatment or in conjunction with bag and cartridge filtration if further treatment is required.
- Sand filters can also be used to provide additional treatment to water treated via settling or basic filtration.

Implementation:

- The filters require delivery to the site and initial set up. The vendor can provide assistance with installation and operation.

Maintenance:

- The filters require regular service to monitor and maintain the level of the sand media. If subjected to high loading rates, filters can plug quickly.
- Venders generally provide data on maximum head loss through the filter. The filter should be monitored daily while in use, and cleaned when head loss reaches target levels.
- If cleaned by backwashing, the backwash water may need to be hauled away for disposal, or returned to the upper end of the treatment train for another pass through the series of dewatering BMPs.

Pressurized Bag Filter



Description:

- A pressurized bag filter is a unit composed of single filter bags made from polyester felt material. The water filters through the unit and is discharged through a header. Vendors provide bag filters in a variety of configurations. Some units include a combination of bag filters and cartridge filters for enhanced contaminant removal.

Appropriate Applications:

- Effective for the removal of sediment (sand and silt) and some metals, as well as the reduction of BOD, turbidity, and hydrocarbons. Oil absorbent bags are available for hydrocarbon removal.
- Filters can be used to provide secondary treatment to water treated via settling or basic filtration.

Implementation:

- The filters require delivery to the site and initial set up. The vendor can provide assistance with installation and operation.

Maintenance:

- The filter bags require replacement when the pressure differential equals or exceeds the manufacturer's recommendation.

Cartridge Filter



Description:

- Cartridge filters provide a high degree of pollutant removal by utilizing a number of individual cartridges as part of a larger filtering unit. They are often used as a secondary or higher (polishing) level of treatment after a significant amount of sediment and other pollutants are removed. Units come with various cartridge configurations (for use in series with bag filters) or with a larger single cartridge filtration unit (with multiple filters within).

Appropriate Applications:

- Effective for the removal of sediment (sand, silt, and some clays) and metals, as well as the reduction of BOD, turbidity, and hydrocarbons. Hydrocarbons can effectively be removed with special resin cartridges.
- Filters can be used to provide secondary treatment to water treated via settling or basic filtration.

Implementation:

- The filters require delivery to the site and initial set up. The vendor can provide assistance.

Maintenance:

- The cartridges require replacement when the pressure differential equals or exceeds the manufacturer's recommendation.

Costs

- Sediment control costs vary considerably depending on the dewatering and sediment treatment system that is selected. Pressurized filters tend to be more expensive than gravity settling, but are often more effective. Simple tanks are generally rented on a long-term basis (one or more months) and can range from \$360 per month for a 1,000 gallon tank to \$2,660 per month for a 10,000 gallon tank. Mobilization and demobilization costs vary considerably.

Inspection and Maintenance

- Inspect and verify that dewatering BMPs are in place and functioning prior to the commencement of activities requiring dewatering.
- Inspect dewatering BMPs daily while dewatering activities are being conducted.

- Inspect all equipment before use. Monitor dewatering operations to ensure they do not cause offsite discharge or erosion.
- Sample dewatering discharges as required by the General Permit.
- Unit-specific maintenance requirements are included with the description of each unit.
- Sediment removed during the maintenance of a dewatering device may be either spread onsite and stabilized, or disposed of at a disposal site as approved by the owner.
- Sediment that is commingled with other pollutants should be disposed of in accordance with all applicable laws and regulations and as approved by the owner.

References

Blueprint for a Clean Bay: Best Management Practices to Prevent Stormwater Pollution from Construction Related Activities; Santa Clara Valley Nonpoint Source Pollution Control Program, 1995.

Stormwater Quality Handbooks - Construction Site Best Management Practices (BMPs) Manual, State of California Department of Transportation (Caltrans), March 2003; Updated March 2004.

Stormwater Management for Construction Activities, Developing Pollution Prevention Plans and Best Management Practices, EPA 832-R-92005; USEPA, April 1992.

Labor Surcharge & Equipment Rental Rates, April 1, 2002 through March 31, 2003, California Department of Transportation (Caltrans).

Erosion and Sediment Control Manual, Oregon Department of Environmental Quality, February 2005.

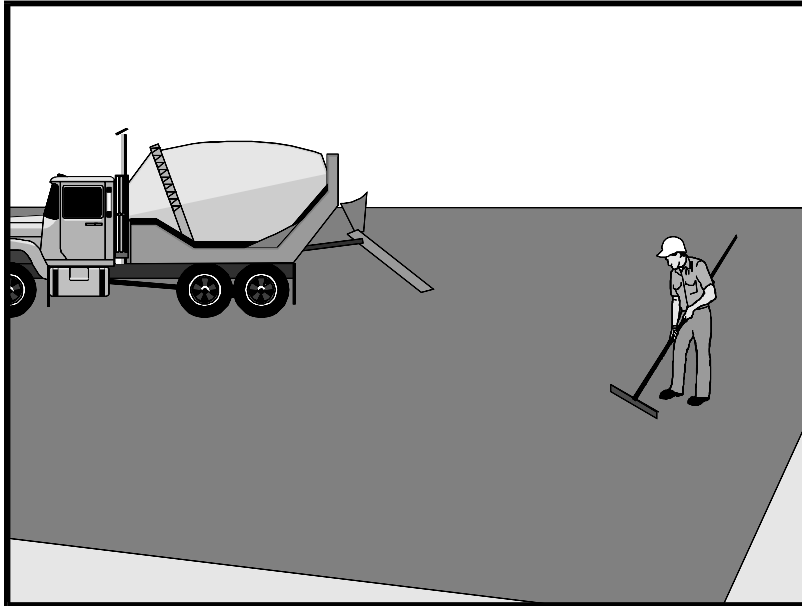

Description and Purpose

Prevent or reduce the discharge of pollutants from paving operations, using measures to prevent runoff and runoff pollution, properly disposing of wastes, and training employees and subcontractors.

The General Permit incorporates Numeric Action Levels (NAL) for pH and turbidity (see Section 2 of this handbook to determine your project's risk level and if you are subject to these requirements).

Many types of construction materials associated with paving and grinding operations, including mortar, concrete, and cement and their associated wastes have basic chemical properties that can raise pH levels outside of the permitted range. Additional care should be taken when managing these materials to prevent them from coming into contact with stormwater flows, which could lead to exceedances of the General Permit requirements.

Suitable Applications

These procedures are implemented where paving, surfacing, resurfacing, or sawcutting, may pollute stormwater runoff or discharge to the storm drain system or watercourses.

Limitations

- Paving opportunities may be limited during wet weather.

Discharges of freshly paved surfaces may raise pH to environmentally harmful levels and trigger permit violations.

Categories

EC	Erosion Control	
SE	Sediment Control	
TC	Tracking Control	
WE	Wind Erosion Control	
NS	Non-Stormwater Management Control	<input checked="" type="checkbox"/>
WM	Waste Management and Materials Pollution Control	<input checked="" type="checkbox"/>

Legend:

- Primary Category
- Secondary Category

Targeted Constituents

Sediment	<input checked="" type="checkbox"/>
Nutrients	
Trash	
Metals	
Bacteria	
Oil and Grease	<input checked="" type="checkbox"/>
Organics	

Potential Alternatives

None

If User/Subscriber modifies this fact sheet in any way, the CASQA name/logo and footer below must be removed from each page and not appear on the modified version.



Implementation

General

- Avoid paving during the wet season when feasible.
- Reschedule paving and grinding activities if rain is forecasted.
- Train employees and sub-contractors in pollution prevention and reduction.
- Store materials away from drainage courses to prevent stormwater runoff (see WM-1, Material Delivery and Storage).
- Protect drainage courses, particularly in areas with a grade, by employing BMPs to divert runoff or to trap and filter sediment.
- Stockpile material removed from roadways away from drain inlets, drainage ditches, and watercourses. These materials should be stored consistent with WM-3, Stockpile Management.
- Disposal of PCC (Portland cement concrete) and AC (asphalt concrete) waste should be in conformance with WM-8, Concrete Waste Management.

Saw Cutting, Grinding, and Pavement Removal

- Shovel or vacuum saw-cut slurry and remove from site. Cover or barricade storm drains during saw cutting to contain slurry.
- When paving involves AC, the following steps should be implemented to prevent the discharge of grinding residue, uncompacted or loose AC, tack coats, equipment cleaners, or unrelated paving materials:
 - AC grindings, pieces, or chunks used in embankments or shoulder backing should not be allowed to enter any storm drains or watercourses. Install inlet protection and perimeter controls until area is stabilized (i.e. cutting, grinding or other removal activities are complete and loose material has been properly removed and disposed of) or permanent controls are in place. Examples of temporary perimeter controls can be found in EC-9, Earth Dikes and Drainage Swales; SE-1, Silt Fence; SE-5, Fiber Rolls, or SE-13 Compost Socks and Berms
 - Collect and remove all broken asphalt and recycle when practical. Old or spilled asphalt should be recycled or disposed of properly.
- Do not allow saw-cut slurry to enter storm drains or watercourses. Residue from grinding operations should be picked up by a vacuum attachment to the grinding machine, or by sweeping, should not be allowed to flow across the pavement, and should not be left on the surface of the pavement. See also WM-8, Concrete Waste Management, and WM-10, Liquid Waste Management.
- Pavement removal activities should not be conducted in the rain.
- Collect removed pavement material by mechanical or manual methods. This material may be recycled for use as shoulder backing or base material.

- If removed pavement material cannot be recycled, transport the material back to an approved storage site.

Asphaltic Concrete Paving

- If paving involves asphaltic cement concrete, follow these steps:
 - Do not allow sand or gravel placed over new asphalt to wash into storm drains, streets, or creeks. Vacuum or sweep loose sand and gravel and properly dispose of this waste by referring to WM-5, Solid Waste Management.
 - Old asphalt should be disposed of properly. Collect and remove all broken asphalt from the site and recycle whenever possible.

Portland Cement Concrete Paving

- Do not wash sweepings from exposed aggregate concrete into a storm drain system. Collect waste materials by dry methods, such as sweeping or shoveling, and return to aggregate base stockpile or dispose of properly. Allow aggregate rinse to settle. Then, either allow rinse water to dry in a temporary pit as described in WM-8, Concrete Waste Management, or pump the water to the sanitary sewer if authorized by the local wastewater authority.

Sealing Operations

- During chip seal application and sweeping operations, petroleum or petroleum covered aggregate should not be allowed to enter any storm drain or water courses. Apply temporary perimeter controls until structure is stabilized (i.e. all sealing operations are complete and cured and loose materials have been properly removed and disposed).
- Inlet protection (SE-10, Storm Drain Inlet Protection) should be used during application of seal coat, tack coat, slurry seal, and fog seal.
- Seal coat, tack coat, slurry seal, or fog seal should not be applied if rainfall is predicted to occur during the application or curing period.

Paving Equipment

- Leaks and spills from paving equipment can contain toxic levels of heavy metals and oil and grease. Place drip pans or absorbent materials under paving equipment when not in use. Clean up spills with absorbent materials and dispose of in accordance with the applicable regulations. See NS-10, Vehicle and Equipment Maintenance, WM-4, Spill Prevention and Control, and WM-10, Liquid Waste Management.
- Substances used to coat asphalt transport trucks and asphalt spreading equipment should not contain soap and should be non-foaming and non-toxic.
- Paving equipment parked onsite should be parked over plastic to prevent soil contamination.
- Clean asphalt coated equipment offsite whenever possible. When cleaning dry, hardened asphalt from equipment, manage hardened asphalt debris as described in WM-5, Solid Waste Management. Any cleaning onsite should follow NS-8, Vehicle and Equipment Cleaning.

Thermoplastic Striping

- Thermoplastic striper and pre-heater equipment shutoff valves should be inspected to ensure that they are working properly to prevent leaking thermoplastic from entering drain inlets, the stormwater drainage system, or watercourses.
- Pre-heaters should be filled carefully to prevent splashing or spilling of hot thermoplastic. Leave six inches of space at the top of the pre-heater container when filling thermoplastic to allow room for material to move.
- Do not pre-heat, transfer, or load thermoplastic near drain inlets or watercourses.
- Clean truck beds daily of loose debris and melted thermoplastic. When possible, recycle thermoplastic material.

Raised/Recessed Pavement Marker Application and Removal

- Do not transfer or load bituminous material near drain inlets, the stormwater drainage system, or watercourses.
- Melting tanks should be loaded with care and not filled to beyond six inches from the top to leave room for splashing.
- When servicing or filling melting tanks, ensure all pressure is released before removing lids to avoid spills.
- On large-scale projects, use mechanical or manual methods to collect excess bituminous material from the roadway after removal of markers.

Costs

- All of the above are low cost measures.

Inspection and Maintenance

- Inspect and verify that activity-based BMPs are in place prior to the commencement of paving and grinding operations.
- BMPs must be inspected in accordance with General Permit requirements for the associated project type and risk level. It is recommended that at a minimum, BMPs be inspected weekly, prior to forecasted rain events, daily during extended rain events, and after the conclusion of rain events.
- Sample stormwater runoff required by the General Permit.
- Keep ample supplies of drip pans or absorbent materials onsite.
- Inspect and maintain machinery regularly to minimize leaks and drips.

References

Blueprint for a Clean Bay: Best Management Practices to Prevent Stormwater Pollution from Construction Related Activities; Santa Clara Valley Nonpoint Source Pollution Control Program, 1995.

Hot Mix Asphalt-Paving Handbook AC 150/5370-14, Appendix I, U.S. Army Corps of Engineers, July 1991.

Stormwater Quality Handbooks - Construction Site Best Management Practices (BMPs) Manual, State of California Department of Transportation (Caltrans), March 2003.

Erosion and Sediment Control Manual, Oregon Department of Environmental Quality, February 2005.

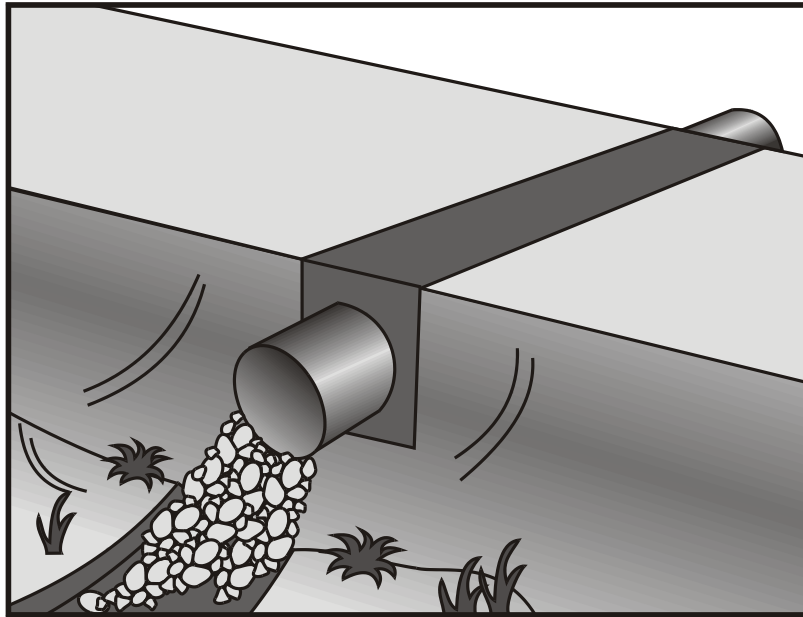

Description and Purpose

A temporary stream crossing is a temporary culvert, ford or bridge placed across a waterway to provide access for construction purposes for a period of less than one year. Temporary access crossings are not intended to maintain traffic for the public. The temporary access will eliminate erosion and downstream sedimentation caused by vehicles.

Suitable Applications

Temporary stream crossings should be installed at all designated crossings of perennial and intermittent streams on the construction site, as well as for dry channels that may be significantly eroded by construction traffic.

Temporary streams crossings are installed at sites:

- Where appropriate permits have been secured (404 Permits, and 401 Certifications)
- Where construction equipment or vehicles need to frequently cross a waterway
- When alternate access routes impose significant constraints
- When crossing perennial streams or waterways causes significant erosion
- Where construction activities will not last longer than one year

Categories

EC	Erosion Control	<input checked="" type="checkbox"/>
SE	Sediment Control	<input checked="" type="checkbox"/>
TC	Tracking Control	<input checked="" type="checkbox"/>
WE	Wind Erosion Control	
NS	Non-Stormwater Management Control	<input checked="" type="checkbox"/>
WM	Waste Management and Materials Pollution Control	

Legend:

- Primary Objective**
- Secondary Objective**

Targeted Constituents

Sediment	<input checked="" type="checkbox"/>
Nutrients	
Trash	
Metals	
Bacteria	
Oil and Grease	
Organics	

Potential Alternatives

None

If User/Subscriber modifies this fact sheet in any way, the CASQA name/logo and footer below must be removed from each page and not appear on the modified version.



- Where appropriate permits have been obtained for the stream crossing

Limitations

The following limitations may apply:

- Installation and removal will usually disturb the waterway.
- Installation may require Regional Water Quality Control Board (RWQCB) 401 Certification, U.S. Army Corps of Engineers 404 permit and approval by California Department of Fish and Game. If numerical-based water quality standards are mentioned in any of these and other related permits, testing and sampling may be required.
- Installation may require dewatering or temporary diversion of the stream. See NS-2, Dewatering Operations and NS-5, Clear Water Diversion.
- Installation may cause a constriction in the waterway, which can obstruct flood flow and cause flow backups or washouts. If improperly designed, flow backups can increase the pollutant load through washouts and scouring.
- Use of natural or other gravel in the stream for construction of Cellular Confinement System (CCS) ford crossing will be contingent upon approval by fisheries agencies.
- Ford crossings may degrade water quality due to contact with vehicles and equipment.
- May be expensive for a temporary improvement.
- Requires other BMPs to minimize soil disturbance during installation and removal.
- Fords should only be used in dry weather.

Implementation

General

The purpose of this BMP is to provide a safe, erosion-free access across a stream for construction equipment. Minimum standards and specifications for the design, construction, maintenance, and removal of the structure should be established by an engineer registered in California. Temporary stream crossings may be necessary to prevent construction equipment from causing erosion of the stream and tracking sediment and other pollutants into the stream.

Temporary stream crossings are used as access points to construction sites when other detour routes may be too long or burdensome for the construction equipment. Often heavy construction equipment must cross streams or creeks, and detour routes may impose too many constraints such as being too narrow or poor soil strength for the equipment loadings. Additionally, the contractor may find a temporary stream crossing more economical for light-duty vehicles to use for frequent crossings, and may have less environmental impact than construction of a temporary access road.

Location of the temporary stream crossing should address:

- Site selection where erosion potential is low.

- Areas where the side slopes from site runoff will not spill into the side slopes of the crossing.

The following types of temporary stream crossings should be considered:

- **Culverts** – A temporary culvert is effective in controlling erosion but will cause erosion during installation and removal. A temporary culvert can be easily constructed and allows for heavy equipment loads.
- **Fords** - Appropriate during the dry season in arid areas. Used on dry washes and ephemeral streams, and low-flow perennial streams. CCS, a type of ford crossing, is also appropriate for use in streams that would benefit from an influx of gravels. A temporary ford provides little sediment and erosion control and is ineffective in controlling erosion in the stream channel. A temporary ford is the least expensive stream crossing and allows for maximum load limits. It also offers very low maintenance. Fords are more appropriate during the dry ice season and in arid areas of California.
- **Bridges** - Appropriate for streams with high flow velocities, steep gradients and where temporary restrictions in the channel are not allowed.

Design

During the long summer construction season in much of California, rainfall is infrequent and many streams are dry. Under these conditions, a temporary ford may be sufficient. A ford is not appropriate if construction will continue through the winter rainy season, if summer thunderstorms are likely, or if the stream flows during most of the year. Temporary culverts and bridges should then be considered and, if used, should be sized to pass a significant design storm (i.e., at least a 10-year storm). The temporary stream crossing should be protected against erosion, both to prevent excessive sedimentation in the stream and to prevent washout of the crossing.

Design and installation requires knowledge of stream flows and soil strength. Designs should be prepared under direction of, and approved by, a registered civil engineer and for bridges, a registered structural engineer. Both hydraulic and construction loading requirements should be considered with the following:

- Comply with any special requirements for culvert and bridge crossings, particularly if the temporary stream crossing will remain through the rainy season.
- Provide stability in the crossing and adjacent areas to withstand the design flow. The design flow and safety factor should be selected based on careful evaluation of the risks due to over topping, flow backups, or washout.
- Install sediment traps immediately downstream of crossings to capture sediments. See SE-3, Sediment Trap.
- Avoid oil or other potentially hazardous materials for surface treatment.
- Culverts are relatively easy to construct and able to support heavy equipment loads.
- Fords are the least expensive of the crossings, with maximum load limits.

- CCS crossing structures consist of clean, washed gravel and cellular confinement system blocks. CCS are appropriate for streams that would benefit from an influx of gravel; for example, salmonid streams, streams or rivers below reservoirs, and urban, channelized streams. Many urban stream systems are gravel-deprived due to human influences, such as dams, gravel mines, and concrete channels.
- CCS allow designers to use either angular or naturally occurring rounded gravel, because the cells provide the necessary structure and stability. In fact, natural gravel is optimal for this technique, because of the habitat improvement it will provide after removal of the CCS.
- A gravel depth of 6 to 12 in. for a CCS structure is sufficient to support most construction equipment.
- An advantage of a CCS crossing structure is that relatively little rock or gravel is needed, because the CCS provides the stability.
- Bridges are generally more expensive to design and construct, but provide the least disturbance of the streambed and constriction of the waterway flows.

Construction and Use

- Stabilize construction roadways, adjacent work area, and stream bottom against erosion.
- Construct during dry periods to minimize stream disturbance and reduce costs.
- Construct at or near the natural elevation of the streambed to prevent potential flooding upstream of the crossing.
- Install temporary erosion control BMPs in accordance with erosion control BMP fact sheets to minimize erosion of embankment into flow lines.
- Any temporary artificial obstruction placed within flowing water should only be built from material, such as clean gravel or sandbags, that will not introduce sediment or silt into the watercourse.
- Temporary water body crossings and encroachments should be constructed to minimize scour. Cobbles used for temporary water body crossings or encroachments should be clean, rounded river cobble.
- Vehicles and equipment should not be driven, operated, fueled, cleaned, maintained, or stored in the wet or dry portions of a water body where wetland vegetation, riparian vegetation, or aquatic organisms may be destroyed.
- The exterior of vehicles and equipment that will encroach on the water body within the project should be maintained free of grease, oil, fuel, and residues.
- Drip pans should be placed under all vehicles and equipment placed on docks, barges, or other structures over water bodies when the vehicle or equipment is planned to be idle for more than one hour.

- Disturbance or removal of vegetation should not exceed the minimum necessary to complete operations. Precautions should be taken to avoid damage to vegetation by people or equipment. Disturbed vegetation should be replaced with the appropriate soil stabilization measures.
- Riparian vegetation, when removed pursuant to the provisions of the work, should be cut off no lower than ground level to promote rapid re-growth. Access roads and work areas built over riparian vegetation should be covered by a sufficient layer of clean river run cobble to prevent damage to the underlying soil and root structure. The cobble must be removed upon completion of project activities.
- Conceptual temporary stream crossings are shown in the attached figures.

Costs

Caltrans Construction Cost index for temporary bridge crossings is \$45-\$95/ft².

Inspection and Maintenance

- Inspect and verify that activity-based BMPs are in place prior to the commencement of associated activities. While activities associated with the BMP are under way, inspect BMPs in accordance with General Permit requirements for the associated project type and risk level. It is recommended that at a minimum, BMPs be inspected weekly, prior to forecasted rain events, daily during extended rain events, and after the conclusion of rain events.
- Check for blockage in the channel, sediment buildup or trapped debris in culverts, blockage behind fords or under bridges.
- Check for erosion of abutments, channel scour, riprap displacement, or piping in the soil.
- Check for structural weakening of the temporary crossings, such as cracks, and undermining of foundations and abutments.
- Remove sediment that collects behind fords, in culverts, and under bridges periodically.
- Replace lost or displaced aggregate from inlets and outlets of culverts and cellular confinement systems.
- Remove temporary crossing promptly when it is no longer needed.

References

California Bank and Shore Rock Slope Protection Design – Practitioners Guide and Field Evaluations of Riprap Methods, Caltrans Study No. F90TLO3, October 2000.

Stormwater Quality Handbooks - Construction Site Best Management Practices (BMPs) Manual, State of California Department of Transportation (Caltrans), November 2000.

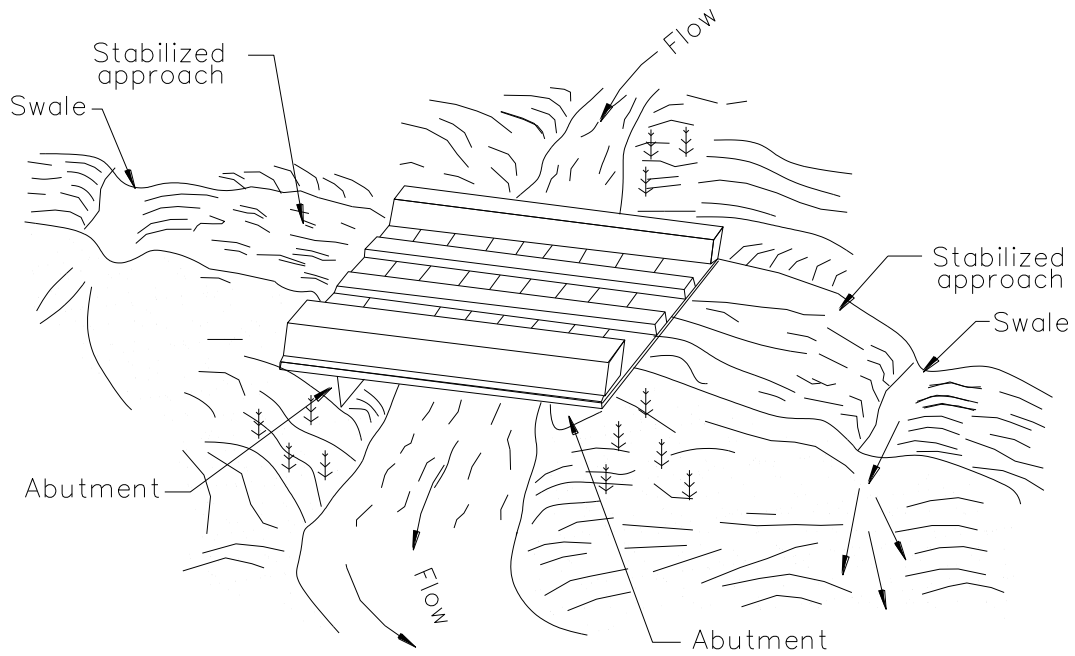

NOTE:
Surface flow of road diverted
by swale and/or dike.

TYPICAL BRIDGE CROSSING
NOT TO SCALE

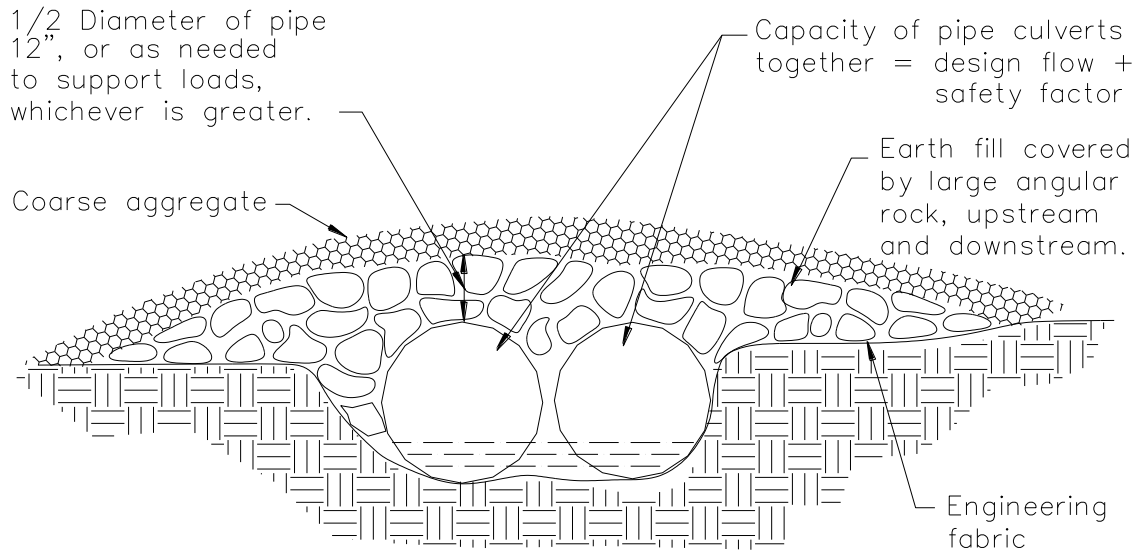

ELEVATION

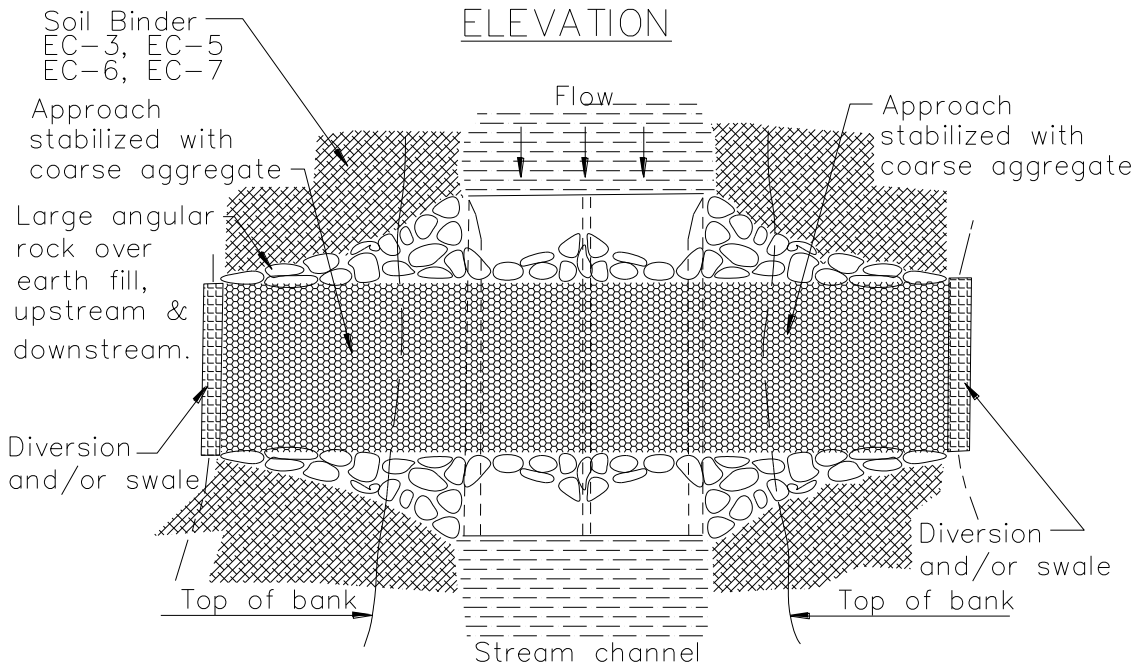

PLAN VIEW

TYPICAL CULVERT CROSSING
NOT TO SCALE

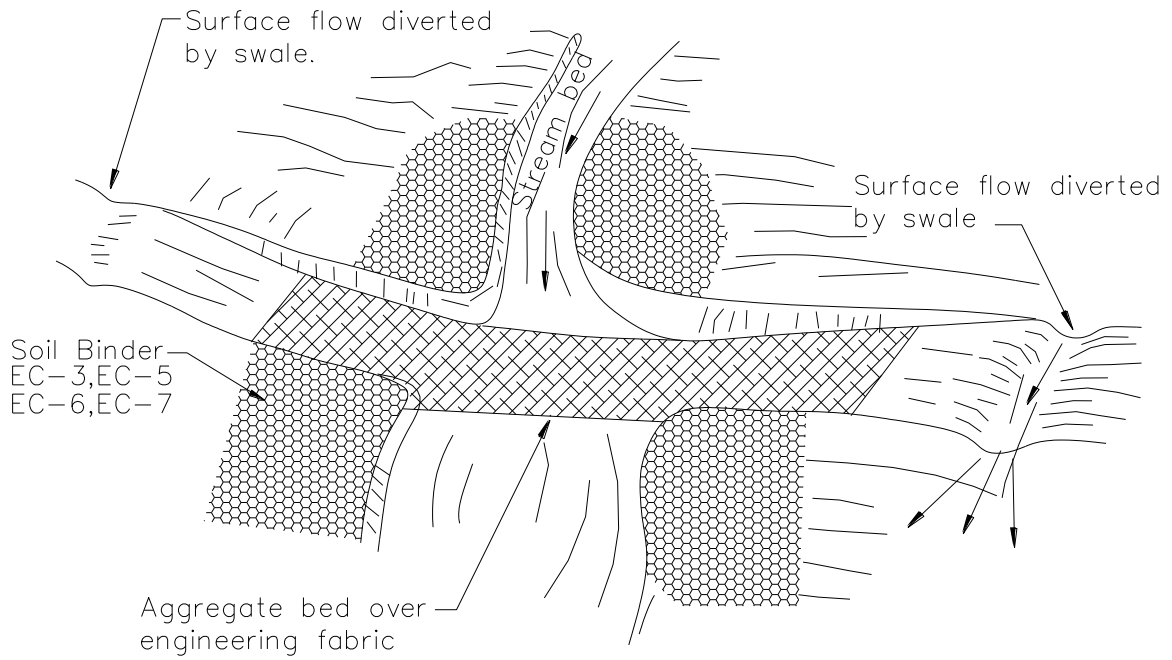

Aggregate approach
1:5 (V:H) Maximum slope on road

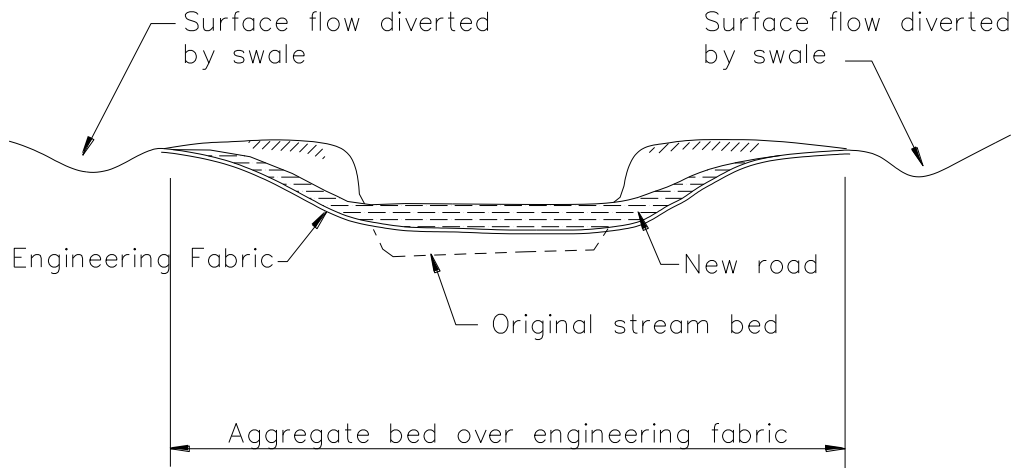

TYPICAL FORD CROSSING
NOT TO SCALE

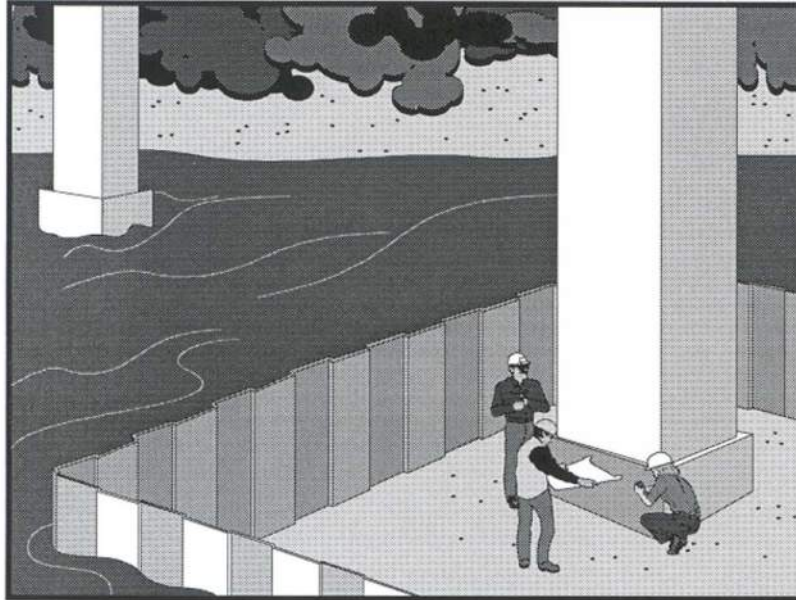

Description and Purpose

Clear water diversion consists of a system of structures and measures that intercept clear surface water runoff upstream of a project, transport it around the work area, and discharge it downstream with minimal water quality degradation from either the project construction operations or the construction of the diversion. Clear water diversions are used in a waterway to enclose a construction area and reduce sediment pollution from construction work occurring in or adjacent to water. Structures commonly used as part of this system include diversion ditches, berms, dikes, slope drains, rock, gravel bags, wood, aqua barriers, cofferdams, filter fabric or turbidity curtains, drainage and interceptor swales, pipes, or flumes.

Suitable Applications

A clear water diversion is typically implemented where appropriate permits (1601 Agreement) have been secured and work must be performed in a flowing stream or water body.

- Clear water diversions are appropriate for isolating construction activities occurring within or near a water body such as streambank stabilization, or culvert, bridge, pier or abutment installation. They may also be used in combination with other methods, such as clear water bypasses and/or pumps.
- Pumped diversions are suitable for intermittent and low flow streams.
- Excavation of a temporary bypass channel, or passing the flow through a heavy pipe (called a “flume”) with a trench

Categories

EC	Erosion Control	
SE	Sediment Control	
TC	Tracking Control	
WE	Wind Erosion Control	
NS	Non-Stormwater Management Control	<input checked="" type="checkbox"/>
WM	Waste Management and Materials Pollution Control	

Legend:

- Primary Objective
- Secondary Objective

Targeted Constituents

Sediment	<input checked="" type="checkbox"/>
Nutrients	
Trash	
Metals	
Bacteria	
Oil and Grease	
Organics	

Potential Alternatives

None

If User/Subscriber modifies this fact sheet in any way, the CASQA name/logo and footer below must be removed from each page and not appear on the modified version.



excavated under it, is appropriate for the diversion of streams less than 20 ft wide, with flow rates less than 100 cfs.

- Clear water diversions incorporating clean washed gravel may be appropriate for use in salmonid spawning streams.

Limitations

- Diversion and encroachment activities will usually disturb the waterway during installation and removal of diversion structures.
- Installation may require Regional Water Quality Control Board (RWQCB) 401 Certification, U.S. Army Corps of Engineers 404 permit and approval by California Department of Fish and Game. If numerical-based water quality standards are mentioned in any of these and other related permits, testing and sampling may be required.
- Diversion and encroachment activities may constrict the waterway, which can obstruct flood flows and cause flooding or washouts. Diversion structures should not be installed without identifying potential impacts to the stream channel.
- Diversion or isolation activities are not appropriate in channels where there is insufficient stream flow to support aquatic species in the area dewatered as a result of the diversion.
- Diversion or isolation activities are inappropriate in deep water unless designed or reviewed by an engineer registered in California.
- Diversion or isolation activities should not completely dam stream flow.
- Dewatering and removal may require additional sediment control or water treatment. See NS-2, Dewatering Operations.
- Not appropriate if installation, maintenance, and removal of the structures will disturb sensitive aquatic species of concern.

Implementation

General

- Implement guidelines presented in EC-12, Streambank Stabilization to minimize impacts to streambanks.
- Where working areas encroach on flowing streams, barriers adequate to prevent the flow of muddy water into streams should be constructed and maintained between working areas and streams. During construction of the barriers, muddying of streams should be held to a minimum.
- Diversion structures must be adequately designed to accommodate fluctuations in water depth or flow volume due to tides, storms, flash floods, etc.
- Heavy equipment driven in wet portions of a water body to accomplish work should be completely clean of petroleum residue, and water levels should be below the fuel tanks, gearboxes, and axles of the equipment unless lubricants and fuels are sealed such that inundation by water will not result in discharges of fuels, oils, greases, or hydraulic fluids.

- Excavation equipment buckets may reach out into the water for the purpose of removing or placing fill materials. Only the bucket of the crane/ excavator/backhoe may operate in a water body. The main body of the crane/excavator/backhoe should not enter the water body except as necessary to cross the stream to access the work site.
- Stationary equipment such as motors and pumps located within or adjacent to a water body, should be positioned over drip pans.
- When any artificial obstruction is being constructed, maintained, or placed in operation, sufficient water should, at all times, be allowed to pass downstream to maintain aquatic life.
- Equipment should not be parked below the high water mark unless allowed by a permit.
- Disturbance or removal of vegetation should not exceed the minimum necessary to complete operations. Precautions should be taken to avoid damage to vegetation by people or equipment. Disturbed vegetation should be replaced with the appropriate erosion control measures.
- Riparian vegetation approved for trimming as part of the project should be cut off no lower than ground level to promote rapid re-growth. Access roads and work areas built over riparian vegetation should be covered by a sufficient layer of clean river run cobble to prevent damage to the underlying soil and root structure. The cobble should be removed upon completion of project activities.
- Drip pans should be placed under all vehicles and equipment placed on docks, barges, or other structures over water bodies when the vehicle or equipment is planned to be idle for more than 1 hour.
- Where possible, avoid or minimize diversion and encroachment impacts by scheduling construction during periods of low flow or when the stream is dry. Scheduling should also consider seasonal releases of water from dams, fish migration and spawning seasons, and water demands due to crop irrigation.
- Construct diversion structures with materials free of potential pollutants such as soil, silt, sand, clay, grease, or oil.

Temporary Diversions and Encroachments

- Construct diversion channels in accordance with EC-9, Earth Dikes and Drainage Swales.
- In high flow velocity areas, stabilize slopes of embankments and diversion ditches using an appropriate liner, in accordance with EC-7, Geotextiles and Mats, or use rock slope protection.
- Where appropriate, use natural streambed materials such as large cobbles and boulders for temporary embankment and slope protection, or other temporary soil stabilization methods.
- Provide for velocity dissipation at transitions in the diversion, such as the point where the stream is diverted to the channel and the point where the diverted stream is returned to its natural channel. See also EC-10, Velocity Dissipation Devices.

Temporary Dry Construction Areas

- When dewatering behind temporary structures to create a temporary dry construction area, such as cofferdams, pass pumped water through a sediment-settling device, such as a portable tank or settling basin, before returning water to the water body. See also NS-2, Dewatering Operations.
- Any substance used to assemble or maintain diversion structures, such as form oil, should be non-toxic and non-hazardous.
- Any material used to minimize seepage underneath diversion structures, such as grout, should be non-toxic, non-hazardous, and as close to a neutral pH as possible.

Comparison of Diversion and Isolation Techniques:

- Gravel bags are relatively inexpensive, but installation and removal can be labor intensive. It is also difficult to dewater the isolated area. Sandbags should not be used for this technique in rivers or streams, as sand should never be put into or adjacent to a stream, even if encapsulated in geotextile.
- Gravel Bag Berms (SE-6) used in conjunction with an impermeable membrane are cost effective, and can be dewatered relatively easily. If spawning gravel is used, the impermeable membrane can be removed from the stream, and the gravel can be spread out and left as salmonid spawning habitat if approved in the permit. Only clean, washed gravel should be used for both the gravel bag and gravel berm techniques.
- Cofferdams are relatively expensive, but frequently allow full dewatering. Also, many options now available are relatively easy to install.
- Sheet pile enclosures are a much more expensive solution, but do allow full dewatering. This technique is not well suited to small streams, but can be effective on large rivers or lakes, and where staging and heavy equipment access areas are available.
- K-rails are an isolation method that does not allow full dewatering, but can be used in small to large watercourses, and in fast-water situations.
- A relatively inexpensive isolation method is filter fabric isolation. This method involves placement of gravel bags or continuous berms to 'key-in' the fabric, and subsequently staking the fabric in place. This method should be used in relatively calm water, and can be used in smaller streams. Note that this is not a dewatering method, but rather a sediment isolation method.
- Turbidity curtains should be used where sediment discharge to a stream is unavoidable. They can also be used for in-stream construction, when dewatering an area is not required.
- When used in watercourses or streams, cofferdams must be used in accordance with permit requirements.
- Manufactured diversion structures should be installed following manufacturer's specifications.

- Filter fabric and turbidity curtain isolation installation methods can be found in the specific technique descriptions that follow.

Filter Fabric Isolation Technique

Definition and Purpose

A filter fabric isolation structure is a temporary structure built into a waterway to enclose a construction area and reduce sediment pollution from construction work in or adjacent to water. This structure is composed of filter fabric, gravel bags, and steel t-posts.

Appropriate Applications

- Filter fabric may be used for construction activities such as streambank stabilization, or culvert, bridge, pier or abutment installation. It may also be used in combination with other methods, such as clean water bypasses and/or pumps.
- Filter fabric isolation is relatively inexpensive. This method involves placement of gravel bags or continuous berms to ‘key-in’ the fabric, and subsequently staking the fabric in place.
- If spawning gravel is used, all other components of the isolation can be removed from the stream, and the gravel may be spread out and left as salmonid spawning habitat if approved in the permit. Whether spawning gravel or other types of gravel are used, only clean washed gravel should be used as infill for the gravel bags or continuous berm.
- This method should be used in relatively calm water, and can be used in smaller streams. This is not a dewatering method, but rather a sediment isolation method.
- Water levels inside and outside the fabric curtain must be about the same, as differential heads will cause the curtain to collapse.

Limitations

- Do not use if the installation, maintenance and removal of the structures will disturb sensitive aquatic species of concern.
- Filter fabrics are not appropriate for projects where dewatering is necessary.
- Filter fabrics are not appropriate to completely dam stream flow.

Design and Installation

- For the filter fabric isolation method, a non-woven or heavy-duty fabric is recommended over standard silt fence. Using rolled geotextiles allows non-standard widths to be used.
- Anchor filter fabric with gravel bags filled with clean, washed gravel. Do not use sand. If a bag should split open, the gravel can be left in the stream, where it can provide aquatic habitat benefits. If a sandbag splits open in a watercourse, the sand could cause a decrease in water quality, and could bury sensitive aquatic habitat.
- Another anchor alternative is a continuous berm, made with the Continuous Berm Machine. This is a gravel-filled bag that can be made in very long segments. The length of the berms is usually limited to 18 ft for ease of handling (otherwise, it gets too heavy to move).

- Place the fabric on the bottom of the stream, and place either a bag of clean, washed gravel or a continuous berm over the bottom of the silt fence fabric, such that a bag-width of fabric lies on the stream bottom. The bag should be placed on what will be the outside of the isolation area.
- Pull the fabric up, and place a metal t-post immediately behind the fabric, on the inside of the isolation area; attach the silt fence to the post with three diagonal nylon ties.
- Continue placing fabric as described above until the entire work area has been isolated, staking the fabric at least every 6 ft.

Inspection and Maintenance

- Immediately repair any gaps, holes or scour.
- Remove and properly dispose of sediment buildup.
- Remove BMP upon completion of construction activity. Recycle or reuse if applicable.
- Revegetate areas disturbed by BMP removal if needed.

Turbidity Curtain Isolation Technique

Definition and Purpose

A turbidity curtain is a fabric barrier used to isolate the near shore work area. The barriers are intended to confine the suspended sediment. The curtain is a floating barrier, and thus does not prevent water from entering the isolated area; rather, it prevents suspended sediment from getting out.

Appropriate Applications

Turbidity curtains should be used where sediment discharge to a stream is unavoidable. They are used when construction activities adjoin quiescent waters, such as lakes, ponds, and slow flowing rivers. The curtains are designed to deflect and contain sediment within a limited area and provide sufficient retention time so that the sediment particles will fall out of suspension.

Limitations

- Turbidity curtains should not be used in flowing water; they are best suited for use in ponds, lakes, and very slow-moving rivers.
- Turbidity curtains should not be placed across the width of a channel.
- Removing sediment that has been deflected and settled out by the curtain may create a discharge problem through the resuspension of particles and by accidental dumping by the removal equipment.

Design and Installation

- Turbidity curtains should be oriented parallel to the direction of flow.
- The curtain should extend the entire depth of the watercourse in calm-water situations.
- In wave conditions, the curtain should extend to within 1 ft of the bottom of the watercourse, such that the curtain does not stir up sediment by hitting the bottom repeatedly. If it is

desirable for the curtain to reach the bottom in an active-water situation, a pervious filter fabric may be used for the bottom 1 ft.

- The top of the curtain should consist of flexible flotation buoys, and the bottom should be held down by a load line incorporated into the curtain fabric. The fabric should be a brightly colored impervious mesh.
- The curtain should be held in place by anchors placed at least every 100 ft.
- First, place the anchors, then tow the fabric out in a furled condition, and connect to the anchors. The anchors should be connected to the flotation devices, and not to the bottom of the curtain. Once in place, cut the furling lines, and allow the bottom of the curtain to sink.
- Consideration must be given to the probable outcome of the removal procedure. It must be determined if it will create more of a sediment problem through re-suspension of the particles or by accidental dumping of material during removal. It is recommended that the soil particles trapped by the turbidity curtain only be removed if there has been a significant change in the original contours of the affected area in the watercourse.
- Particles should always be allowed to settle for a minimum of 6 to 12 hours prior to their removal or prior to removal of the turbidity curtain.

Maintenance and Inspection:

- The curtain should be inspected for holes or other problems, and any repairs needed should be made promptly.
- Allow sediment to settle for 6 to 12 hours prior to removal of sediment or curtain. This means that after removing sediment, wait an additional 6 to 12 hours before removing the curtain.
- To remove, install furling lines along the curtain, detach from anchors, and tow out of the water.

K-rail River Isolation

Definition and Purpose

This temporary sediment control or stream isolation method uses K-rails to form the sediment deposition area, or to isolate the in-stream or near-bank construction area.

Barriers are placed end-to-end in a pre-designed configuration and gravel-filled bags are used at the toe of the barrier and at their abutting ends to seal and prevent movement of sediment beneath or through the barrier walls.

Appropriate Applications

The K-rail isolation can be used in streams with higher water velocities than many other isolation techniques.

- This technique is also useful at the toe of embankments, and cut or fill slopes.

Limitations

- The K-rail method should not be used to dewater a project site, as the barrier is not watertight.

Design and Installation

- To create a floor for the K-rail, move large rocks and obstructions. Place washed gravel and gravel-filled bags to create a level surface for K-rails to sit. Washed gravel should always be used.
- Place the bottom two K-rails adjacent to each other, and parallel to the direction of flow; fill the center portion with gravel bags. Then place the third K-rail on top of the bottom two. There should be sufficient gravel bags between the bottom K-rails such that the top rail is supported by the gravel. Place plastic sheeting around the K-rails, and secure at the bottom with gravel bags.
- Further support can be added by pinning and cabling the K-rails together. Also, large riprap and boulders can be used to support either side of the K-rail, especially where there is strong current.

Inspection and Maintenance:

- The barrier should be inspected and any leaks, holes, or other problems should be addressed immediately.
- Sediment should be allowed to settle for at least 6 to 12 hours prior to removal of sediment, and for 6 to 12 hours prior to removal of the barrier.

Stream Diversions

The selection of which stream diversion technique to use will depend upon the type of work involved, physical characteristics of the site, and the volume of water flowing through the project.

Advantages of a Pumped Diversion

- Downstream sediment transport can be nearly eliminated.
- Dewatering of the work area is possible.
- Pipes can be moved around to allow construction operations.
- The dams can serve as temporary access to the site.
- Increased flows can be managed by adding more pumping capacity.

Disadvantages of a Pumped Diversion

- Flow volume is limited by pump capacity.
- A pumped diversion requires 24 hour monitoring of pumps.
- Sudden rain could overtop dams.
- Erosion at the outlet.

- Minor in-stream disturbance is required to install and remove dams.

Advantages of Excavated Channels and Flumes

- Excavated channels isolate work from water flow and allow dewatering.
- Excavated channels can handle larger flows than pumps.

Disadvantages of Excavated Channels and Flumes

- Bypass channel or flume must be sized to handle flows, including possible floods.
- Channels must be protected from erosion.
- Flow diversion and re-direction with small dams involves in-stream disturbance and mobilization of sediment.

Design and Installation

- Installation guidelines will vary based on existing site conditions and type of diversion used.
- Pump capacity must be sufficient for design flow.
- A standby pump is required in case a primary pump fails.
- Dam materials used to create dams upstream and downstream of diversion should be erosion resistant; materials such as steel plate, sheet pile, sandbags, continuous berms, inflatable water bladders, etc., would be acceptable.

When constructing a diversion channel, begin excavation of the channel at the proposed downstream end, and work upstream. Once the watercourse to be diverted is reached and the excavated channel is stable, breach the upstream end and allow water to flow down the new channel. Once flow has been established in the diversion channel, install the diversion weir in the main channel; this will force all water to be diverted from the main channel.

Inspection and Maintenance

- Pumped diversions require 24 hour monitoring of pumps.
- Inspect embankments and diversion channels for damage to the linings, accumulating debris, sediment buildup, and adequacy of the slope protection. Remove debris and repair linings and slope protection as required. Remove holes, gaps, or scour.
- Upon completion of work, the diversion or isolation structure should be removed and flow should be redirected through the new culvert or back into the original stream channel. Recycle or reuse if applicable.
- Revegetate areas disturbed by BMP removal if needed.

Costs

Costs of clear water diversion vary considerably and can be very high.

Inspection and Maintenance

- Inspect and verify that activity-based BMPs are in place prior to the commencement of associated activities. While activities associated with the BMP are under way, inspect BMPs in accordance with General Permit requirements for the associated project type and risk level. It is recommended that at a minimum, BMPs be inspected weekly, prior to forecasted rain events, daily during extended rain events, and after the conclusion of rain events.
- Inspect BMPs subject to non-stormwater discharges daily while non-stormwater discharges occur.
- Refer to BMP-specific inspection and maintenance requirements.

References

California Bank and Shore Rock Slope Protection Design – Practitioners Guide and Field Evaluations of Riprap Methods, Caltrans Study No. F90TL03, October, 2000.

Stormwater Quality Handbooks - Construction Site Best Management Practices (BMPs) Manual, State of California Department of Transportation (Caltrans), November 2000.

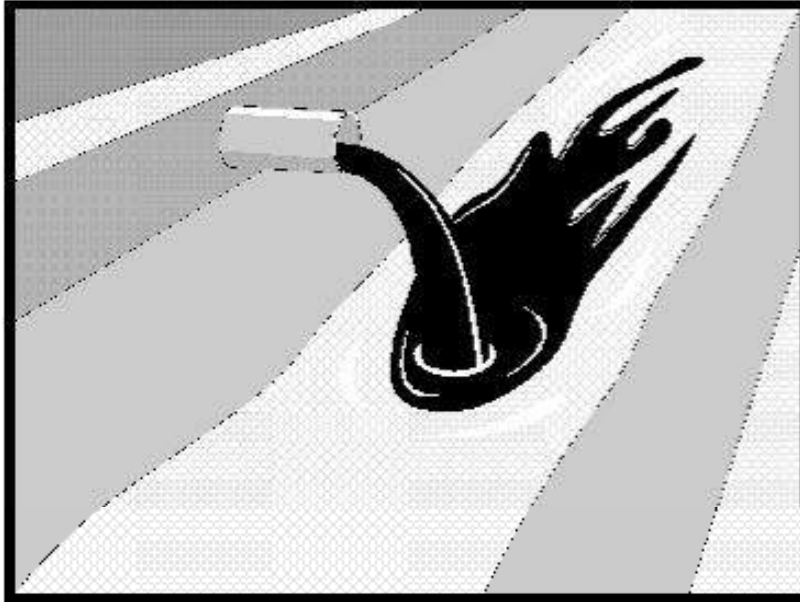

Categories

EC	Erosion Control	
SE	Sediment Control	
TC	Tracking Control	
WE	Wind Erosion Control	
NS	Non-Stormwater Management Control	<input checked="" type="checkbox"/>
WM	Waste Management and Materials Pollution Control	

Legend:

- Primary Objective
- Secondary Objective

Targeted Constituents

Sediment	
Nutrients	<input checked="" type="checkbox"/>
Trash	<input checked="" type="checkbox"/>
Metals	<input checked="" type="checkbox"/>
Bacteria	<input checked="" type="checkbox"/>
Oil and Grease	<input checked="" type="checkbox"/>
Organics	<input checked="" type="checkbox"/>

Potential Alternatives

None

If User/Subscriber modifies this fact sheet in any way, the CASQA name/logo and footer below must be removed from each page and not appear on the modified version.

Description and Purpose

Procedures and practices designed for construction contractors to recognize illicit connections or illegally dumped or discharged materials on a construction site and report incidents.

Suitable Applications

This best management practice (BMP) applies to all construction projects. Illicit connection/discharge and reporting is applicable anytime an illicit connection or discharge is discovered or illegally dumped material is found on the construction site.

Limitations

Illicit connections and illegal discharges or dumping, for the purposes of this BMP, refer to discharges and dumping caused by parties other than the contractor. If pre-existing hazardous materials or wastes are known to exist onsite, they should be identified in the SWPPP and handled as set forth in the SWPPP.

Implementation

Planning

- Review the SWPPP. Pre-existing areas of contamination should be identified and documented in the SWPPP.
- Inspect site before beginning the job for evidence of illicit connections, illegal dumping or discharges. Document any pre-existing conditions and notify the owner.



- Inspect site regularly during project execution for evidence of illicit connections, illegal dumping or discharges.
- Observe site perimeter for evidence for potential of illicitly discharged or illegally dumped material, which may enter the job site.

Identification of Illicit Connections and Illegal Dumping or Discharges

- **General** – unlabeled and unidentifiable material should be treated as hazardous.
- **Solids** - Look for debris, or rubbish piles. Solid waste dumping often occurs on roadways with light traffic loads or in areas not easily visible from the traveled way.
- **Liquids** - signs of illegal liquid dumping or discharge can include:
 - Visible signs of staining or unusual colors to the pavement or surrounding adjacent soils
 - Pungent odors coming from the drainage systems
 - Discoloration or oily substances in the water or stains and residues detained within ditches, channels or drain boxes
 - Abnormal water flow during the dry weather season
- **Urban Areas** - Evidence of illicit connections or illegal discharges is typically detected at storm drain outfall locations or at manholes. Signs of an illicit connection or illegal discharge can include:
 - Abnormal water flow during the dry weather season
 - Unusual flows in sub drain systems used for dewatering
 - Pungent odors coming from the drainage systems
 - Discoloration or oily substances in the water or stains and residues detained within ditches, channels or drain boxes
 - Excessive sediment deposits, particularly adjacent to or near active offsite construction projects
- **Rural Areas** - Illicit connections or illegal discharges involving irrigation drainage ditches are detected by visual inspections. Signs of an illicit discharge can include:
 - Abnormal water flow during the non-irrigation season
 - Non-standard junction structures
 - Broken concrete or other disturbances at or near junction structures

Reporting

Notify the owner of any illicit connections and illegal dumping or discharge incidents at the time of discovery. For illicit connections or discharges to the storm drain system, notify the local stormwater management agency. For illegal dumping, notify the local law enforcement agency.

Cleanup and Removal

The responsibility for cleanup and removal of illicit or illegal dumping or discharges will vary by location. Contact the local stormwater management agency for further information.

Costs

Costs to look for and report illicit connections and illegal discharges and dumping are low. The best way to avoid costs associated with illicit connections and illegal discharges and dumping is to keep the project perimeters secure to prevent access to the site, to observe the site for vehicles that should not be there, and to document any waste or hazardous materials that exist onsite before taking possession of the site.

Inspection and Maintenance

- Inspect and verify that activity-based BMPs are in place prior to the commencement of associated activities. While activities associated with the BMP are under way, inspect BMPs in accordance with General Permit requirements for the associated project type and risk level. It is recommended that at a minimum, BMPs be inspected weekly, prior to forecasted rain events, daily during extended rain events, and after the conclusion of rain events.
- Inspect the site regularly to check for any illegal dumping or discharge.
- Prohibit employees and subcontractors from disposing of non-job related debris or materials at the construction site.
- Notify the owner of any illicit connections and illegal dumping or discharge incidents at the time of discovery.

References

Blueprint for a Clean Bay: Best Management Practices to Prevent Stormwater Pollution from Construction Related Activities; Santa Clara Valley Nonpoint Source Pollution Control Program, 1995.

Stormwater Quality Handbooks - Construction Site Best Management Practices (BMPs) Manual, State of California Department of Transportation (Caltrans), November 2000.

Stormwater Management for Construction Activities, Developing Pollution Prevention Plans and Best Management Practices, EPA 832-R-92005; USEPA, April 1992.

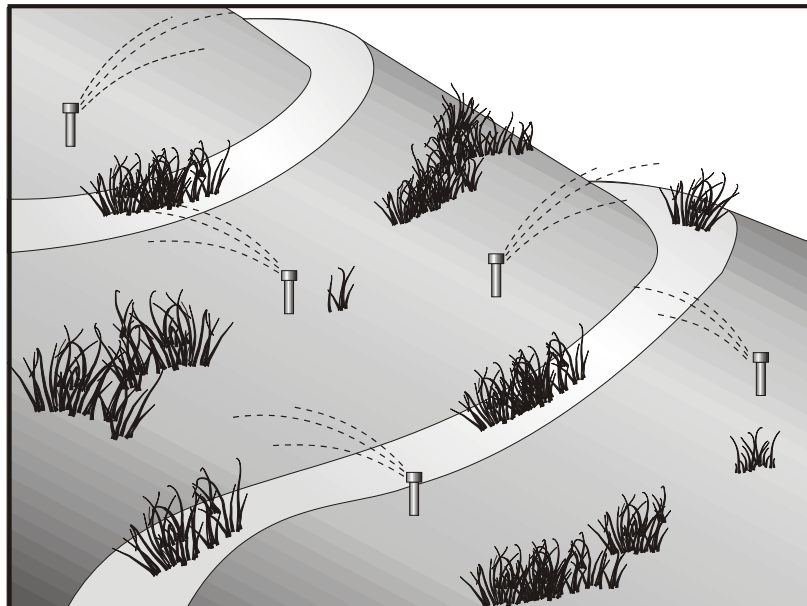

Description and Purpose

Potable Water/Irrigation consists of practices and procedures to manage the discharge of potential pollutants generated during discharges from irrigation water lines, landscape irrigation, lawn or garden watering, planned and unplanned discharges from potable water sources, water line flushing, and hydrant flushing.

Suitable Applications

Implement this BMP whenever potable water or irrigation water discharges occur at or enter a construction site.

Limitations

None identified.

Implementation

- Direct water from offsite sources around or through a construction site, where feasible, in a way that minimizes contact with the construction site.
- Discharges from water line flushing should be reused for landscaping purposes where feasible.
- Shut off the water source to broken lines, sprinklers, or valves as soon as possible to prevent excess water flow.
- Protect downstream stormwater drainage systems and watercourses from water pumped or bailed from trenches excavated to repair water lines.

Categories

EC	Erosion Control	
SE	Sediment Control	
TC	Tracking Control	
WE	Wind Erosion Control	
NS	Non-Stormwater Management Control	<input checked="" type="checkbox"/>
WM	Waste Management and Materials Pollution Control	

Legend:

- Primary Objective
- Secondary Objective

Targeted Constituents

Sediment	<input checked="" type="checkbox"/>
Nutrients	<input checked="" type="checkbox"/>
Trash	
Metals	<input checked="" type="checkbox"/>
Bacteria	
Oil and Grease	
Organics	<input checked="" type="checkbox"/>

Potential Alternatives

None

If User/Subscriber modifies this fact sheet in any way, the CASQA name/logo and footer below must be removed from each page and not appear on the modified version.



- Inspect irrigated areas within the construction limits for excess watering. Adjust watering times and schedules to ensure that the appropriate amount of water is being used and to minimize runoff. Consider factors such as soil structure, grade, time of year, and type of plant material in determining the proper amounts of water for a specific area.

Costs

Cost to manage potable water and irrigation are low and generally considered to be a normal part of related activities.

Inspection and Maintenance

- Inspect and verify that activity-based BMPs are in place prior to the commencement of associated activities. While activities associated with the BMP are under way, inspect BMPs in accordance with General Permit requirements for the associated project type and risk level. It is recommended that at a minimum, BMPs be inspected weekly, prior to forecasted rain events, daily during extended rain events, and after the conclusion of rain events..
- Inspect BMPs subject to non-stormwater discharges daily while non-stormwater discharges occur.
- Repair broken water lines as soon as possible.
- Inspect irrigated areas regularly for signs of erosion and/or discharge.

References

Blueprint for a Clean Bay: Best Management Practices to Prevent Stormwater Pollution from Construction Related Activities; Santa Clara Valley Nonpoint Source Pollution Control Program, 1995.

Stormwater Quality Handbooks - Construction Site Best Management Practices (BMPs) Manual, State of California Department of Transportation (Caltrans), November 2000.

Stormwater Management for Construction Activities, Developing Pollution Prevention Plans and Best Management Practices, EPA 832-R-92005; USEPA, April 1992.

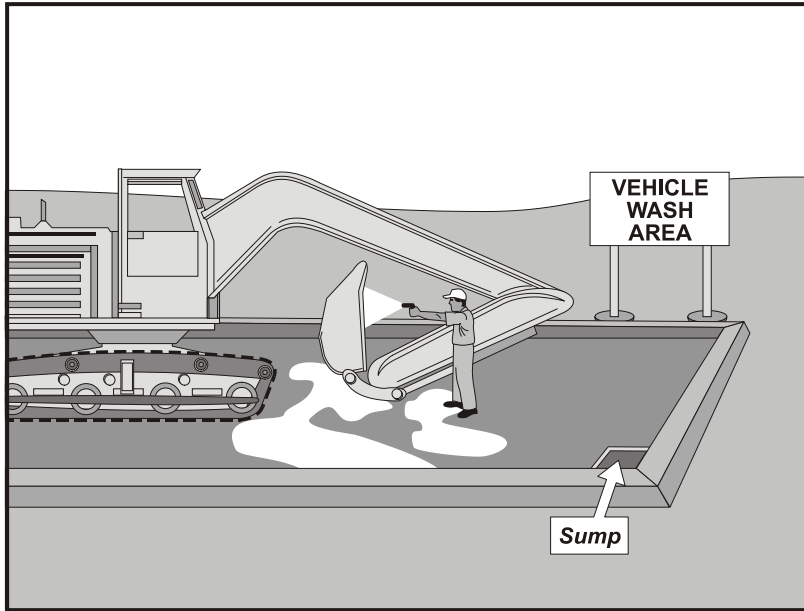

Description and Purpose

Vehicle and equipment cleaning procedures and practices eliminate or reduce the discharge of pollutants to stormwater from vehicle and equipment cleaning operations. Procedures and practices include but are not limited to: using offsite facilities; washing in designated, contained areas only; eliminating discharges to the storm drain by infiltrating the wash water; and training employees and subcontractors in proper cleaning procedures.

Suitable Applications

These procedures are suitable on all construction sites where vehicle and equipment cleaning is performed.

Limitations

Even phosphate-free, biodegradable soaps have been shown to be toxic to fish before the soap degrades. Sending vehicles/equipment offsite should be done in conjunction with TC-1, Stabilized Construction Entrance/Exit.

Implementation

Other options to washing equipment onsite include contracting with either an offsite or mobile commercial washing business. These businesses may be better equipped to handle and dispose of the wash waters properly. Performing this work offsite can also be economical by eliminating the need for a separate washing operation onsite.

If washing operations are to take place onsite, then:

Categories

EC	Erosion Control	
SE	Sediment Control	
TC	Tracking Control	
WE	Wind Erosion Control	
NS	Non-Stormwater Management Control	<input checked="" type="checkbox"/>
WM	Waste Management and Materials Pollution Control	

Legend:

- Primary Objective
- Secondary Objective

Targeted Constituents

Sediment	<input checked="" type="checkbox"/>
Nutrients	<input checked="" type="checkbox"/>
Trash	
Metals	
Bacteria	
Oil and Grease	<input checked="" type="checkbox"/>
Organics	<input checked="" type="checkbox"/>

Potential Alternatives

None

If User/Subscriber modifies this fact sheet in any way, the CASQA name/logo and footer below must be removed from each page and not appear on the modified version.



- Use phosphate-free, biodegradable soaps.
- Educate employees and subcontractors on pollution prevention measures.
- Do not permit steam cleaning onsite. Steam cleaning can generate significant pollutant concentrates.
- Cleaning of vehicles and equipment with soap, solvents or steam should not occur on the project site unless resulting wastes are fully contained and disposed of. Resulting wastes should not be discharged or buried, and must be captured and recycled or disposed according to the requirements of WM-10, Liquid Waste Management or WM-6, Hazardous Waste Management, depending on the waste characteristics. Minimize use of solvents. Use of diesel for vehicle and equipment cleaning is prohibited.
- All vehicles and equipment that regularly enter and leave the construction site must be cleaned offsite.
- When vehicle and equipment washing and cleaning must occur onsite, and the operation cannot be located within a structure or building equipped with appropriate disposal facilities, the outside cleaning area should have the following characteristics:
 - Located away from storm drain inlets, drainage facilities, or watercourses
 - Paved with concrete or asphalt and bermed to contain wash waters and to prevent runoff
 - Configured with a sump to allow collection and disposal of wash water
 - No discharge of wash waters to storm drains or watercourses
 - Used only when necessary
- When cleaning vehicles and equipment with water:
 - Use as little water as possible. High-pressure sprayers may use less water than a hose and should be considered
 - Use positive shutoff valve to minimize water usage
 - Facility wash racks should discharge to a sanitary sewer, recycle system or other approved discharge system and must not discharge to the storm drainage system, watercourses, or to groundwater

Costs

Cleaning vehicles and equipment at an offsite facility may reduce overall costs for vehicle and equipment cleaning by eliminating the need to provide similar services onsite. When onsite cleaning is needed, the cost to establish appropriate facilities is relatively low on larger, long-duration projects, and moderate to high on small, short-duration projects.

Inspection and Maintenance

- Inspect and verify that activity-based BMPs are in place prior to the commencement of associated activities. While activities associated with the BMP are under way, inspect BMPs in accordance with General Permit requirements for the associated project type and risk level. It is recommended that at a minimum, BMPs be inspected weekly, prior to forecasted rain events, daily during extended rain events, and after the conclusion of rain events.
- Inspect BMPs subject to non-stormwater discharges daily while non-stormwater discharges occur.
- Inspection and maintenance is minimal, although some berm repair may be necessary.
- Monitor employees and subcontractors throughout the duration of the construction project to ensure appropriate practices are being implemented.
- Inspect sump regularly and remove liquids and sediment as needed.
- Prohibit employees and subcontractors from washing personal vehicles and equipment on the construction site.

References

Stormwater Quality Handbooks - Construction Site Best Management Practices (BMPs) Manual, State of California Department of Transportation (Caltrans), November 2000.

Swisher, R.D. Surfactant Biodegradation, Marcel Decker Corporation, 1987.

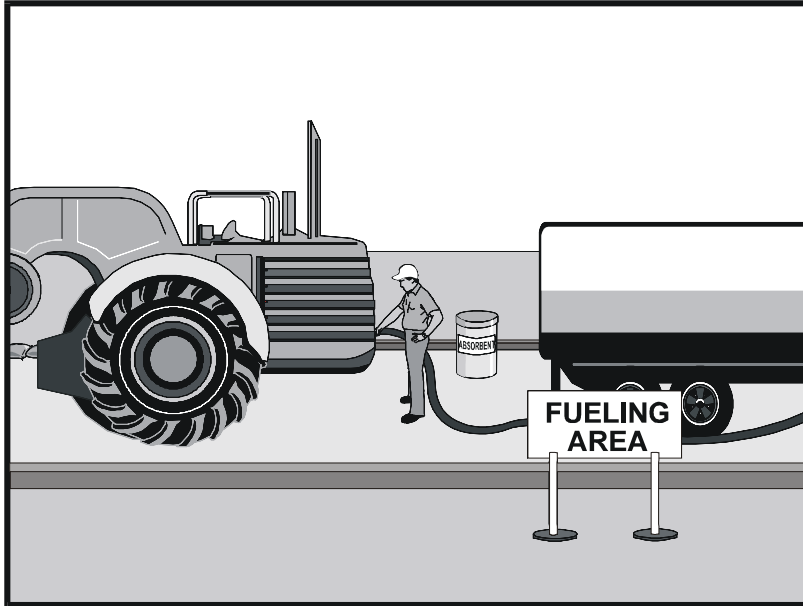

Description and Purpose

Vehicle equipment fueling procedures and practices are designed to prevent fuel spills and leaks, and reduce or eliminate contamination of stormwater. This can be accomplished by using offsite facilities, fueling in designated areas only, enclosing or covering stored fuel, implementing spill controls, and training employees and subcontractors in proper fueling procedures.

Suitable Applications

These procedures are suitable on all construction sites where vehicle and equipment fueling takes place.

Limitations

Onsite vehicle and equipment fueling should only be used where it is impractical to send vehicles and equipment offsite for fueling. Sending vehicles and equipment offsite should be done in conjunction with TC-1, Stabilized Construction Entrance/ Exit.

Implementation

- Use offsite fueling stations as much as possible. These businesses are better equipped to handle fuel and spills properly. Performing this work offsite can also be economical by eliminating the need for a separate fueling area at a site.
- Discourage “topping-off” of fuel tanks.

Categories

EC	Erosion Control	
SE	Sediment Control	
TC	Tracking Control	
WE	Wind Erosion Control	
NS	Non-Stormwater Management Control	<input checked="" type="checkbox"/>
WM	Waste Management and Materials Pollution Control	

Legend:

- Primary Objective
- Secondary Objective

Targeted Constituents

Sediment	
Nutrients	
Trash	
Metals	
Bacteria	
Oil and Grease	<input checked="" type="checkbox"/>
Organics	

Potential Alternatives

None

If User/Subscriber modifies this fact sheet in any way, the CASQA name/logo and footer below must be removed from each page and not appear on the modified version.



- Absorbent spill cleanup materials and spill kits should be available in fueling areas and on fueling trucks, and should be disposed of properly after use.
- Drip pans or absorbent pads should be used during vehicle and equipment fueling, unless the fueling is performed over an impermeable surface in a dedicated fueling area.
- Use absorbent materials on small spills. Do not hose down or bury the spill. Remove the adsorbent materials promptly and dispose of properly.
- Avoid mobile fueling of mobile construction equipment around the site; rather, transport the equipment to designated fueling areas. With the exception of tracked equipment such as bulldozers and large excavators, most vehicles should be able to travel to a designated area with little lost time.
- Train employees and subcontractors in proper fueling and cleanup procedures.
- When fueling must take place onsite, designate an area away from drainage courses to be used. Fueling areas should be identified in the SWPPP.
- Dedicated fueling areas should be protected from stormwater runoff and should be located at least 50 ft away from downstream drainage facilities and watercourses. Fueling must be performed on level-grade areas.
- Protect fueling areas with berms and dikes to prevent runoff, and to contain spills.
- Nozzles used in vehicle and equipment fueling should be equipped with an automatic shutoff to control drips. Fueling operations should not be left unattended.
- Use vapor recovery nozzles to help control drips as well as air pollution where required by Air Quality Management Districts (AQMD).
- Federal, state, and local requirements should be observed for any stationary above ground storage tanks.

Costs

- All of the above measures are low cost except for the capital costs of above ground tanks that meet all local environmental, zoning, and fire codes.

Inspection and Maintenance

- Inspect BMPs in accordance with General Permit requirements for the associated project type and risk level. It is recommended that at a minimum, BMPs be inspected weekly, prior to forecasted rain events, daily during extended rain events, and after the conclusion of rain events.
- Vehicles and equipment should be inspected each day of use for leaks. Leaks should be repaired immediately or problem vehicles or equipment should be removed from the project site.
- Keep ample supplies of spill cleanup materials onsite.

- Immediately clean up spills and properly dispose of contaminated soil and cleanup materials.

References

Blueprint for a Clean Bay: Best Management Practices to Prevent Stormwater Pollution from Construction Related Activities; Santa Clara Valley Nonpoint Source Pollution Control Program, 1995.

Coastal Nonpoint Pollution Control Program: Program Development and Approval Guidance, Working Group Working Paper; USEPA, April 1992.

Stormwater Quality Handbooks - Construction Site Best Management Practices (BMPs) Manual, State of California Department of Transportation (Caltrans), November 2000.

Stormwater Management for Construction Activities, Developing Pollution Prevention Plans and Best Management Practices, EPA 832-R-92005; USEPA, April 1992.

Vehicle & Equipment Maintenance NS-10

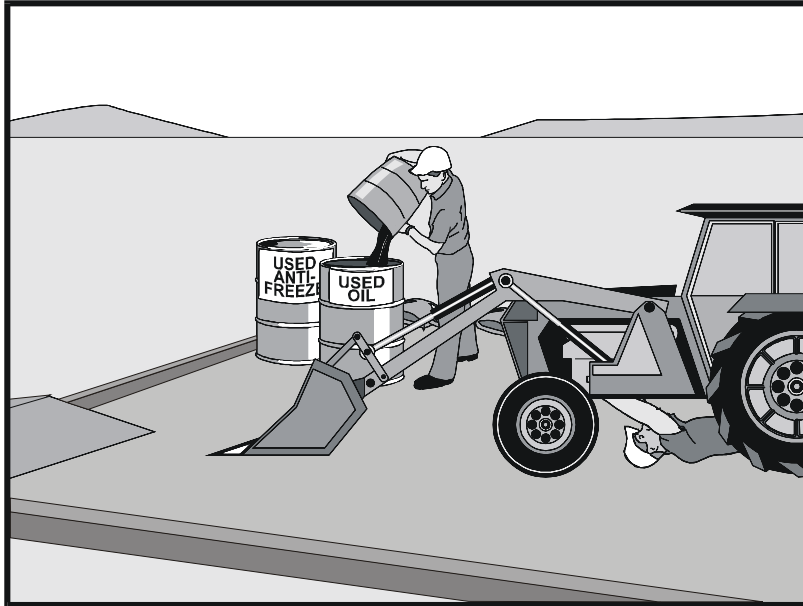

Description and Purpose

Prevent or reduce the contamination of stormwater resulting from vehicle and equipment maintenance by running a “dry and clean site”. The best option would be to perform maintenance activities at an offsite facility. If this option is not available then work should be performed in designated areas only, while providing cover for materials stored outside, checking for leaks and spills, and containing and cleaning up spills immediately. Employees and subcontractors must be trained in proper procedures.

Suitable Applications

These procedures are suitable on all construction projects where an onsite yard area is necessary for storage and maintenance of heavy equipment and vehicles.

Limitations

Onsite vehicle and equipment maintenance should only be used where it is impractical to send vehicles and equipment offsite for maintenance and repair. Sending vehicles/equipment offsite should be done in conjunction with TC-1, Stabilized Construction Entrance/Exit.

Outdoor vehicle or equipment maintenance is a potentially significant source of stormwater pollution. Activities that can contaminate stormwater include engine repair and service, changing or replacement of fluids, and outdoor equipment storage and parking (engine fluid leaks). For further information on vehicle or equipment servicing, see NS-8,

Categories

EC	Erosion Control	
SE	Sediment Control	
TC	Tracking Control	
WE	Wind Erosion Control	
NS	Non-Stormwater Management Control	<input checked="" type="checkbox"/>
WM	Waste Management and Materials Pollution Control	

Legend:

- Primary Objective
- Secondary Objective

Targeted Constituents

Sediment	
Nutrients	<input checked="" type="checkbox"/>
Trash	<input checked="" type="checkbox"/>
Metals	
Bacteria	
Oil and Grease	<input checked="" type="checkbox"/>
Organics	<input checked="" type="checkbox"/>

Potential Alternatives

None

If User/Subscriber modifies this fact sheet in any way, the CASQA name/logo and footer below must be removed from each page and not appear on the modified version.



Vehicle & Equipment Maintenance NS-10

Vehicle and Equipment Cleaning, and NS-9, Vehicle and Equipment Fueling.

Implementation

- Use offsite repair shops as much as possible. These businesses are better equipped to handle vehicle fluids and spills properly. Performing this work offsite can also be economical by eliminating the need for a separate maintenance area.
- If maintenance must occur onsite, use designated areas, located away from drainage courses. Dedicated maintenance areas should be protected from stormwater runoff and should be located at least 50 ft from downstream drainage facilities and watercourses.
- Drip pans or absorbent pads should be used during vehicle and equipment maintenance work that involves fluids, unless the maintenance work is performed over an impermeable surface in a dedicated maintenance area.
- Place a stockpile of spill cleanup materials where it will be readily accessible.
- All fueling trucks and fueling areas are required to have spill kits and/or use other spill protection devices.
- Use adsorbent materials on small spills. Remove the adsorbent materials promptly and dispose of properly.
- Inspect onsite vehicles and equipment daily at startup for leaks, and repair immediately.
- Keep vehicles and equipment clean; do not allow excessive build-up of oil and grease.
- Segregate and recycle wastes, such as greases, used oil or oil filters, antifreeze, cleaning solutions, automotive batteries, hydraulic and transmission fluids. Provide secondary containment and covers for these materials if stored onsite.
- Train employees and subcontractors in proper maintenance and spill cleanup procedures.
- Drip pans or plastic sheeting should be placed under all vehicles and equipment placed on docks, barges, or other structures over water bodies when the vehicle or equipment is planned to be idle for more than 1 hour.
- For long-term projects, consider using portable tents or covers over maintenance areas if maintenance cannot be performed offsite.
- Consider use of new, alternative greases and lubricants, such as adhesive greases, for chassis lubrication and fifth-wheel lubrication.
- Properly dispose of used oils, fluids, lubricants, and spill cleanup materials.
- Do not place used oil in a dumpster or pour into a storm drain or watercourse.
- Properly dispose of or recycle used batteries.
- Do not bury used tires.

Vehicle & Equipment Maintenance NS-10

- Repair leaks of fluids and oil immediately.

Listed below is further information if you must perform vehicle or equipment maintenance onsite.

Safer Alternative Products

- Consider products that are less toxic or hazardous than regular products. These products are often sold under an “environmentally friendly” label.
- Consider use of grease substitutes for lubrication of truck fifth-wheels. Follow manufacturers label for details on specific uses.
- Consider use of plastic friction plates on truck fifth-wheels in lieu of grease. Follow manufacturers label for details on specific uses.

Waste Reduction

Parts are often cleaned using solvents such as trichloroethylene, trichloroethane, or methylene chloride. Many of these cleaners are listed in California Toxic Rule as priority pollutants. These materials are harmful and must not contaminate stormwater. They must be disposed of as a hazardous waste. Reducing the number of solvents makes recycling easier and reduces hazardous waste management costs. Often, one solvent can perform a job as well as two different solvents. Also, if possible, eliminate or reduce the amount of hazardous materials and waste by substituting non-hazardous or less hazardous materials. For example, replace chlorinated organic solvents with non-chlorinated solvents. Non-chlorinated solvents like kerosene or mineral spirits are less toxic and less expensive to dispose of properly. Check the list of active ingredients to see whether it contains chlorinated solvents. The “chlor” term indicates that the solvent is chlorinated. Also, try substituting a wire brush for solvents to clean parts.

Recycling and Disposal

Separating wastes allows for easier recycling and may reduce disposal costs. Keep hazardous wastes separate, do not mix used oil solvents, and keep chlorinated solvents (like, -trichloroethane) separate from non-chlorinated solvents (like kerosene and mineral spirits). Promptly transfer used fluids to the proper waste or recycling drums. Don't leave full drip pans or other open containers lying around. Provide cover and secondary containment until these materials can be removed from the site.

Oil filters can be recycled. Ask your oil supplier or recycler about recycling oil filters.

Do not dispose of extra paints and coatings by dumping liquid onto the ground or throwing it into dumpsters. Allow coatings to dry or harden before disposal into covered dumpsters.

Store cracked batteries in a non-leaking secondary container. Do this with all cracked batteries, even if you think all the acid has drained out. If you drop a battery, treat it as if it is cracked. Put it into the containment area until you are sure it is not leaking.

Costs

All of the above are low cost measures. Higher costs are incurred to setup and maintain onsite maintenance areas.

Vehicle & Equipment Maintenance NS-10

Inspection and Maintenance

- Inspect and verify that activity-based BMPs are in place prior to the commencement of associated activities. While activities associated with the BMP are under way, inspect BMPs in accordance with General Permit requirements for the associated project type and risk level. It is recommended that at a minimum, BMPs be inspected weekly, prior to forecasted rain events, daily during extended rain events, and after the conclusion of rain events.
- Inspect BMPs subject to non-stormwater discharges daily while non-stormwater discharges occur.
- Keep ample supplies of spill cleanup materials onsite.
- Maintain waste fluid containers in leak proof condition.
- Vehicles and equipment should be inspected on each day of use. Leaks should be repaired immediately or the problem vehicle(s) or equipment should be removed from the project site.
- Inspect equipment for damaged hoses and leaky gaskets routinely. Repair or replace as needed.

References

Blueprint for a Clean Bay: Best Management Practices to Prevent Stormwater Pollution from Construction Related Activities; Santa Clara Valley Nonpoint Source Pollution Control Program, 1995.

Coastal Nonpoint Pollution Control Program; Program Development and Approval Guidance, Working Group, Working Paper; USEPA, April 1992.

Stormwater Quality Handbooks - Construction Site Best Management Practices (BMPs) Manual, State of California Department of Transportation (Caltrans), November 2000.

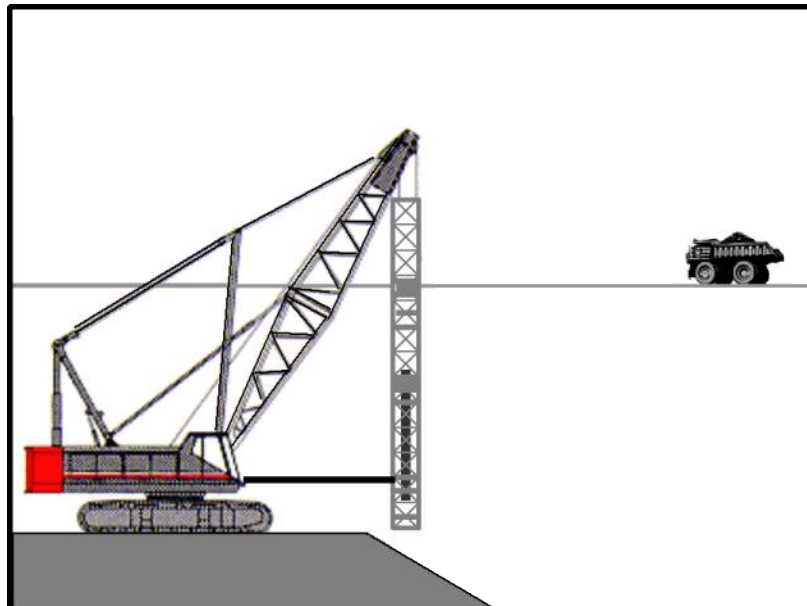

Description and Purpose

The construction and retrofit of bridges and retaining walls often include driving piles for foundation support and shoring operations. Driven piles are typically constructed of precast concrete, steel, or timber. Driven sheet piles are also used for shoring and cofferdam construction. Proper control and use of equipment, materials, and waste products from pile driving operations will reduce or eliminate the discharge of potential pollutants to the storm drain system, watercourses, and waters of the United States.

Suitable Applications

These procedures apply to all construction sites near or adjacent to a watercourse or groundwater where permanent and temporary pile driving (impact and vibratory) takes place, including operations using pile shells as well as construction of cast-in-steel-shell and cast-in-drilled-hole piles.

Limitations

None identified.

Implementation

- Use drip pans or absorbent pads during vehicle and equipment operation, maintenance, cleaning, fueling, and storage. Refer to NS-8, Vehicle and Equipment Cleaning, NS-9, Vehicle and Equipment Fueling, and NS-10, Vehicle and Equipment Maintenance.

Categories

EC	Erosion Control	
SE	Sediment Control	
TC	Tracking Control	
WE	Wind Erosion Control	
NS	Non-Stormwater Management Control	<input checked="" type="checkbox"/>
WM	Waste Management and Materials Pollution Control	

Legend:

- Primary Objective
- Secondary Objective

Targeted Constituents

Sediment	<input checked="" type="checkbox"/>
Nutrients	
Trash	
Metals	
Bacteria	
Oil and Grease	<input checked="" type="checkbox"/>
Organics	

Potential Alternatives

None

If User/Subscriber modifies this fact sheet in any way, the CASQA name/logo and footer below must be removed from each page and not appear on the modified version.



- Have spill kits and cleanup materials available at all locations of pile driving. Refer to WM-4, Spill Prevention and Control.
- Equipment that is stored or in use in streambeds, or on docks, barges, or other structures over water bodies should be kept leak free.
- Park equipment over plastic sheeting or equivalent where possible. Plastic is not a substitute for drip pans or absorbent pads. The storage or use of equipment in streambeds or other bodies of water must comply with all applicable permits.
- Implement other BMPs as applicable, such as NS-2, Dewatering Operations, WM-5, Solid Waste Management, WM-6, Hazardous Waste Management, and WM-10, Liquid Waste Management.
- When not in use, store pile-driving equipment away from concentrated flows of stormwater, drainage courses, and inlets. Protect hammers and other hydraulic attachments from runoff and runoff by placing them on plywood and covering them with plastic or a comparable material prior to the onset of rain.
- Use less hazardous products, e.g., vegetable oil, when practicable.

Costs

All of the above measures can be low cost.

Inspection and Maintenance

- Inspect and verify that activity-based BMPs are in place prior to the commencement of associated activities. While activities associated with the BMP are under way, inspect BMPs in accordance with General Permit requirements for the associated project type and risk level. It is recommended that at a minimum, BMPs be inspected weekly, prior to forecasted rain events, daily during extended rain events, and after the conclusion of rain events.
- Inspect BMPs subject to non-stormwater discharges daily while non-stormwater discharges occur.
- Inspect equipment every day at startup and repair equipment as needed (i.e., worn or damaged hoses, fittings, and gaskets). Recheck equipment at shift changes or at the end of the day and scheduled repairs as needed.

References

Stormwater Quality Handbooks - Construction Site Best Management Practices (BMPs) Manual, State of California Department of Transportation (Caltrans), November 2000.

Stormwater Management for Construction Activities, Developing Pollution Prevention Plans and Best Management Practices, EPA 832-R-92005; USEPA, April 1992.

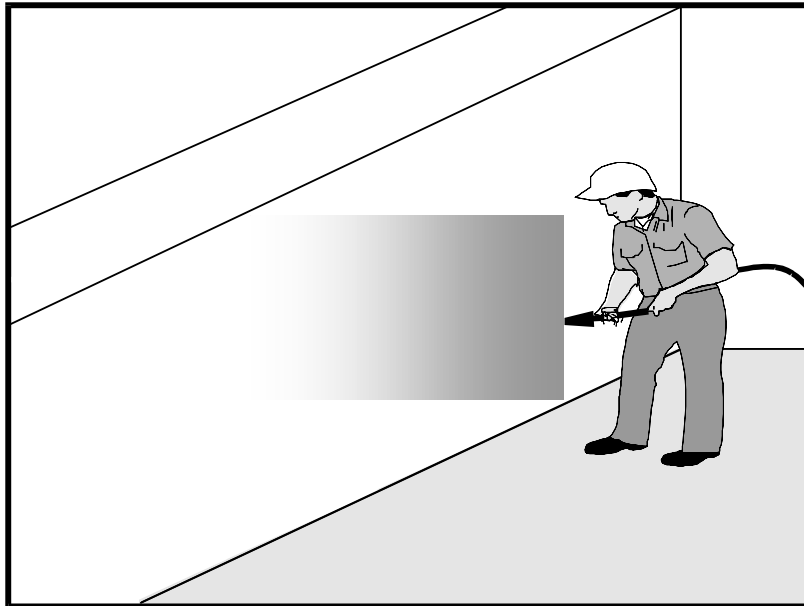

Description and Purpose

Concrete curing is used in the construction of structures such as bridges, retaining walls, pump houses, large slabs, and structured foundations. Concrete curing includes the use of both chemical and water methods.

Concrete and its associated curing materials have basic chemical properties that can raise the pH of water to levels outside of the permitted range. Discharges of stormwater and non-stormwater exposed to concrete during curing may have a high pH and may contain chemicals, metals, and fines. The General Permit incorporates Numeric Action Levels (NAL) for pH (see Section 2 of this handbook to determine your project's risk level and if you are subject to these requirements).

Proper procedures and care should be taken when managing concrete curing materials to prevent them from coming into contact with stormwater flows, which could result in a high pH discharge.

Suitable Applications

Suitable applications include all projects where Portland Cement Concrete (PCC) and concrete curing chemicals are placed where they can be exposed to rainfall, runoff from other areas, or where runoff from the PCC will leave the site.

Limitations

- Runoff contact with concrete waste can raise pH levels in the water to environmentally harmful levels and trigger permit violations.

Categories

EC	Erosion Control	
SE	Sediment Control	
TC	Tracking Control	
WE	Wind Erosion Control	
NS	Non-Stormwater Management Control	<input checked="" type="checkbox"/>
WM	Waste Management and Materials Pollution Control	<input checked="" type="checkbox"/>

Legend:

- Primary Category
- Secondary Category

Targeted Constituents

Sediment	<input checked="" type="checkbox"/>
Nutrients	
Trash	
Metals	<input checked="" type="checkbox"/>
Bacteria	
Oil and Grease	<input checked="" type="checkbox"/>
Organics	

Potential Alternatives

None

If User/Subscriber modifies this fact sheet in any way, the CASQA name/logo and footer below must be removed from each page and not appear on the modified version.



Implementation

Chemical Curing

- Avoid over spray of curing compounds.
- Minimize the drift by applying the curing compound close to the concrete surface. Apply an amount of compound that covers the surface, but does not allow any runoff of the compound.
- Use proper storage and handling techniques for concrete curing compounds. Refer to WM-1, Material Delivery and Storage.
- Protect drain inlets prior to the application of curing compounds.
- Refer to WM-4, Spill Prevention and Control.

Water Curing for Bridge Decks, Retaining Walls, and other Structures

- Direct cure water away from inlets and watercourses to collection areas for evaporation or other means of removal in accordance with all applicable permits. See WM-8 Concrete Waste Management.
- Collect cure water at the top of slopes and transport to a concrete waste management area in a non-erosive manner. See EC-9 Earth Dikes and Drainage Swales, EC-10, Velocity Dissipation Devices, and EC-11, Slope Drains.
- Utilize wet blankets or a similar method that maintains moisture while minimizing the use and possible discharge of water.

Education

- Educate employees, subcontractors, and suppliers on proper concrete curing techniques to prevent contact with discharge as described herein.
- Arrange for the QSP or the appropriately trained contractor's superintendent or representative to oversee and enforce concrete curing procedures.

Costs

All of the above measures are generally low cost.

Inspection and Maintenance

- Inspect and verify that activity-based BMPs are in place prior to the commencement of associated activities.
- BMPs must be inspected in accordance with General Permit requirements for the associated project type and risk level. It is recommended that at a minimum, BMPs be inspected weekly, prior to forecasted rain events, daily during extended rain events, and after the conclusion of rain events.
- Inspect BMPs subject to non-stormwater discharges daily while non-stormwater discharges occur.

- Sample non-stormwater discharges and stormwater runoff that contacts uncured and partially cured concrete as required by the General Permit.
- Ensure that employees and subcontractors implement appropriate measures for storage, handling, and use of curing compounds.
- Inspect cure containers and spraying equipment for leaks.

References

Blue Print for a Clean Bay-Construction-Related Industries: Best Management Practices for Stormwater Pollution Prevention; Santa Clara Valley Non Point Source Pollution Control Program, 1992.

Stormwater Quality Handbooks - Construction Site Best Management Practices (BMPs) Manual, State of California Department of Transportation (Caltrans), March 2003.

Stormwater Management for Construction Activities, Developing Pollution Prevention Plans and Best Management Practices, EPA 832-R-92005; USEPA, April 1992.

Erosion and Sediment Control Manual, Oregon Department of Environmental Quality, February 2005.

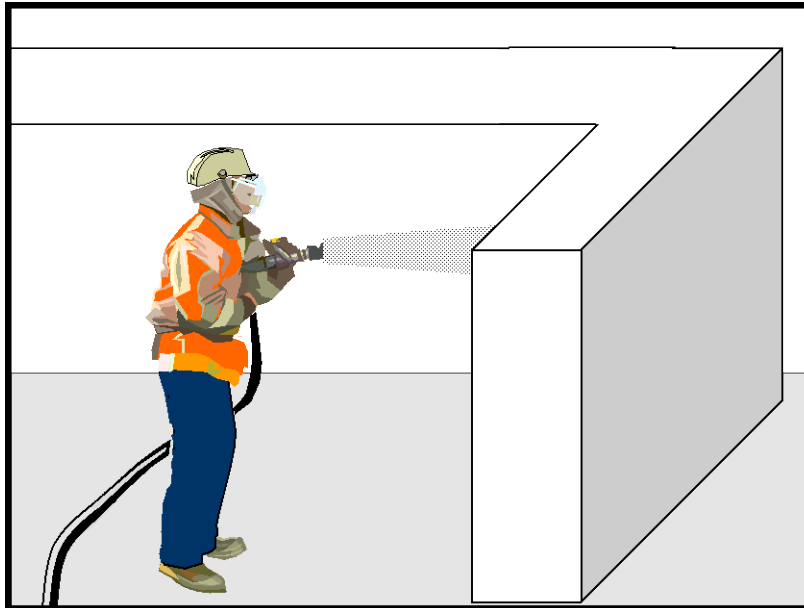

Description and Purpose

Concrete finishing methods are used for bridge deck rehabilitation, paint removal, curing compound removal, and final surface finish appearances. Methods include sand blasting, shot blasting, grinding, or high pressure water blasting. Stormwater and non-stormwater exposed to concrete finishing by-products may have a high pH and may contain chemicals, metals, and fines. Proper procedures and implementation of appropriate BMPs can minimize the impact that concrete-finishing methods may have on stormwater and non-stormwater discharges.

The General Permit incorporates Numeric Action Levels (NAL) for pH (see Section 2 of this handbook to determine your project's risk level and if you are subject to these requirements).

Concrete and its associated curing materials have basic chemical properties that can raise pH levels outside of the permitted range. Additional care should be taken when managing these materials to prevent them from coming into contact with stormwater flows, which could lead to exceedances of the General Permit requirements.

Suitable Applications

These procedures apply to all construction locations where concrete finishing operations are performed.

Categories

EC	Erosion Control	
SE	Sediment Control	
TC	Tracking Control	
WE	Wind Erosion Control	
NS	Non-Stormwater Management Control	<input checked="" type="checkbox"/>
WM	Waste Management and Materials Pollution Control	<input checked="" type="checkbox"/>

Legend:

- Primary Category
- Secondary Category

Targeted Constituents

Sediment	<input checked="" type="checkbox"/>
Nutrients	
Trash	
Metals	<input checked="" type="checkbox"/>
Bacteria	
Oil and Grease	
Organics	<input checked="" type="checkbox"/>

Potential Alternatives

None

If User/Subscriber modifies this fact sheet in any way, the CASQA name/logo and footer below must be removed from each page and not appear on the modified version.



Limitations

- Runoff contact with concrete waste can raise pH levels in the water to environmentally harmful levels and trigger permit violations.

Implementation

- Collect and properly dispose of water from high-pressure water blasting operations.
- Collect contaminated water from blasting operations at the top of slopes. Transport or dispose of contaminated water while using BMPs such as those for erosion control. Refer to EC-9, Earth Dikes and Drainage Swales, EC-10, Velocity Dissipation Devices, and EC-11, Slope Drains.
- Direct water from blasting operations away from inlets and watercourses to collection areas for infiltration or other means of removal (dewatering). Refer to NS-2 Dewatering Operations.
- Protect inlets during sandblasting operations. Refer to SE-10, Storm Drain Inlet Protection.
- Refer to WM-8, Concrete Waste Management for disposal of concrete debris.
- Minimize the drift of dust and blast material as much as possible by keeping the blasting nozzle close to the surface.
- When blast residue contains a potentially hazardous waste, refer to WM-6, Hazardous Waste Management.

Education

- Educate employees, subcontractors, and suppliers on proper concrete finishing techniques to prevent contact with discharge as described herein.
- Arrange for the QSP or the appropriately trained contractor's superintendent or representative to oversee and enforce concrete finishing procedures.

Costs

These measures are generally of low cost.

Inspection and Maintenance

- Inspect and verify that activity-based BMPs are in place prior to the commencement of associated activities.
- BMPs must be inspected in accordance with General Permit requirements for the associated project type and risk level. It is recommended that at a minimum, BMPs be inspected weekly, prior to forecasted rain events, daily during extended rain events, and after the conclusion of rain events.
- Inspect BMPs subject to non-stormwater discharges daily while non-stormwater discharges occur.
- Sample non-stormwater discharges and stormwater runoff that contacts concrete dust and debris as required by the General Permit.

- Sweep or vacuum up debris from sandblasting at the end of each shift.
- At the end of each work shift, remove and contain liquid and solid waste from containment structures, if any, and from the general work area.
- Inspect containment structures for damage prior to use and prior to onset of forecasted rain.

References

Blueprint for a Clean Bay: Best Management Practices to Prevent Stormwater Pollution from Construction Related Activities; Santa Clara Valley Nonpoint Source Pollution Control Program, 1995.

Stormwater Quality Handbooks - Construction Site Best Management Practices (BMPs) Manual, State of California Department of Transportation (Caltrans), March 2003.

Stormwater Management for Construction Activities, Developing Pollution Prevention Plans and Best Management Practices, EPA 832-R-92005; USEPA, April 1992.

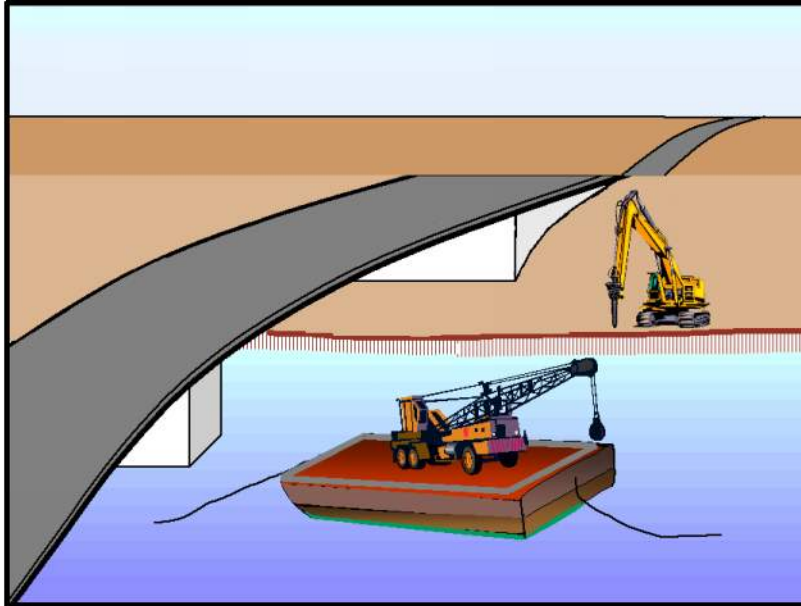

Description and Purpose

Procedures for the proper use, storage, and disposal of materials and equipment on barges, boats, temporary construction pads, or similar locations that minimize or eliminate the discharge of potential pollutants to a watercourse.

Suitable Applications

Applies where materials and equipment are used on barges, boats, docks, and other platforms over or adjacent to a watercourse including waters of the United States. These procedures should be implemented for construction materials and wastes (solid and liquid), soil or dredging materials, or any other materials that may cause or contribute to exceedances of water quality standards.

Limitations

Dredge and fill activities are regulated by the US Army Corps of Engineers and Regional Boards under Section 404/401 of the Clean Water Act.

Implementation

- Refer to WM-1, Material Delivery and Storage and WM-4, Spill Prevention and Control.
- Use drip pans and absorbent materials for equipment and vehicles and ensure that an adequate supply of spill clean up materials is available.
- Drip pans should be placed under all vehicles and equipment placed on docks, barges, or other structures over

Categories

EC	Erosion Control	
SE	Sediment Control	
TC	Tracking Control	
WE	Wind Erosion Control	
NS	Non-Stormwater Management Control	<input checked="" type="checkbox"/>
WM	Waste Management and Materials Pollution Control	<input checked="" type="checkbox"/>

Legend:

- Primary Objective
- Secondary Objective

Targeted Constituents

Sediment	<input checked="" type="checkbox"/>
Nutrients	<input checked="" type="checkbox"/>
Trash	<input checked="" type="checkbox"/>
Metals	<input checked="" type="checkbox"/>
Bacteria	<input checked="" type="checkbox"/>
Oil and Grease	<input checked="" type="checkbox"/>
Organics	<input checked="" type="checkbox"/>

Potential Alternatives

None

If User/Subscriber modifies this fact sheet in any way, the CASQA name/logo and footer below must be removed from each page and not appear on the modified version.



water bodies when the vehicle or equipment is expected to be idle for more than 1 hour.

- Maintain equipment in accordance with NS-10, Vehicle and Equipment Maintenance. If a leaking line cannot be repaired, remove equipment from over the water.
- Provide watertight curbs or toe boards to contain spills and prevent materials, tools, and debris from leaving the barge, platform, dock, etc.
- Secure all materials to prevent discharges to receiving waters via wind.
- Identify types of spill control measures to be employed, including the storage of such materials and equipment. Ensure that staff is trained regarding the use of the materials, deployment and access of control measures, and reporting measures.
- In case of spills, contact the local Regional Board as soon as possible but within 48 hours.
- Refer to WM-5, Solid Waste Management (non-hazardous) and WM-6, Hazardous Waste Management. Ensure the timely and proper removal of accumulated wastes
- Comply with all necessary permits required for construction within or near the watercourse, such as Regional Water Quality Control Board, U.S. Army Corps of Engineers, Department of Fish and Game or and other local permitting.
- Discharges to waterways should be reported to the Regional Water Quality Control Board immediately upon discovery. A written discharge notification must follow within 7 days. Follow the spill reporting procedures contained in SWPPP.

Costs

These measures are generally of low to moderate cost. Exceptions are areas for temporary storage of materials, engine fluids, or wastewater pump out.

Inspection and Maintenance

- Inspect and verify that activity-based BMPs are in place prior to the commencement of associated activities. While activities associated with the BMP are under way, inspect BMPs in accordance with General Permit requirements for the associated project type and risk level. It is recommended that at a minimum, BMPs be inspected weekly, prior to forecasted rain events, daily during extended rain events, and after the conclusion of rain events.
- Inspect BMPs subject to non-stormwater discharge daily while non-stormwater discharges occur.
- Ensure that employees and subcontractors implement the appropriate measures for storage and use of materials and equipment.
- Inspect and maintain all associated BMPs and perimeter controls to ensure continuous protection of the water courses, including waters of the United States.

References

Stormwater Quality Handbooks - Construction Site Best Management Practices (BMPs) Manual, State of California Department of Transportation (Caltrans), November 2000.

Stormwater Management for Construction Activities, Developing Pollution Prevention Plans and Best Management Practices, EPA 832-R-92005; USEPA, April 1992.

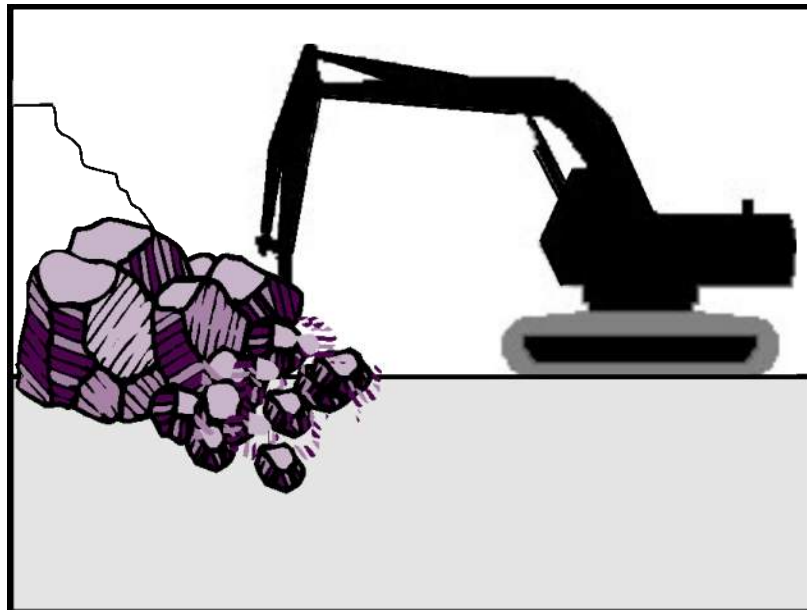

Description and Purpose

Procedures to protect water bodies from debris and wastes associated with structure demolition or removal over or adjacent to watercourses.

Suitable Applications

Full bridge demolition and removal, partial bridge removal (barrier rail, edge of deck) associated with bridge widening projects, concrete channel removal, or any other structure removal that could potentially affect water quality.

Limitations

None identified.

Implementation

- Refer to NS-5, Clear Water Diversion, to direct water away from work areas.
- Use attachments on construction equipment such as backhoes to catch debris from small demolition operations.
- Use covers or platforms to collect debris.
- Platforms and covers are to be approved by the owner.
- Stockpile accumulated debris and waste generated during demolition away from watercourses and in accordance with WM-3, Stockpile Management.
- Ensure safe passage of wildlife, as necessary.

Categories

EC	Erosion Control	
SE	Sediment Control	
TC	Tracking Control	
WE	Wind Erosion Control	
NS	Non-Stormwater Management Control	<input checked="" type="checkbox"/>
WM	Waste Management and Materials Pollution Control	

Legend:

- Primary Objective
- Secondary Objective

Targeted Constituents

Sediment	<input checked="" type="checkbox"/>
Nutrients	<input checked="" type="checkbox"/>
Trash	<input checked="" type="checkbox"/>
Metals	<input checked="" type="checkbox"/>
Bacteria	<input checked="" type="checkbox"/>
Oil and Grease	<input checked="" type="checkbox"/>
Organics	<input checked="" type="checkbox"/>

Potential Alternatives

None

If User/Subscriber modifies this fact sheet in any way, the CASQA name/logo and footer below must be removed from each page and not appear on the modified version.



- Discharges to waterways shall be reported to the Regional Water Quality Control Board immediately upon discovery. A written discharge notification must follow within 7 days. Follow the spill reporting procedures in the SWPPP.
- For structures containing hazardous materials, i.e., lead paint or asbestos, refer to BMP WM-6, Hazardous Waste Management. For demolition work involving soil excavation around lead-painted structures, refer to WM-7, Contaminated Soil Management.

Costs

Cost may vary according to the combination of practices implemented.

Inspection and Maintenance

- Inspect and verify that activity-based BMPs are in place prior to the commencement of associated activities. While activities associated with the BMP are under way, inspect BMPs in accordance with General Permit requirements for the associated project type and risk level. It is recommended that at a minimum, BMPs be inspected weekly, prior to forecasted rain events, daily during extended rain events, and after the conclusion of rain events.
- Inspect BMPs subject to non-stormwater discharge daily while non-stormwater discharges occur.
- Any debris-catching devices shall be emptied regularly. Collected debris shall be removed and stored away from the watercourse and protected from runoff.

References

Stormwater Quality Handbooks - Construction Site Best Management Practices (BMPs) Manual, State of California Department of Transportation (Caltrans), November 2000.

Stormwater Management for Construction Activities, Developing Pollution Prevention Plans and Best Management Practices, EPA 832-R-92005; USEPA, April 1992.



Description and Purpose

The construction of roads, bridges, retaining walls, and other large structures in remote areas, often requires temporary batch plant facilities to manufacture Portland Cement Concrete (PCC) or asphalt cement (AC). Temporary batch plant facilities typically consist of silos containing fly ash, lime, and cement; heated tanks of liquid asphalt; sand and gravel material storage areas; mixing equipment; above ground storage tanks containing concrete additives and water; and designated areas for sand and gravel truck unloading, concrete truck loading, and concrete truck washout. Proper control and use of equipment, materials, and waste products from temporary batch plant facilities will reduce the discharge of potential pollutants to the storm drain system or watercourses, reduce air emissions, and mitigate noise impacts.

The General Permit draft incorporates Numeric Action Levels (NAL) for pH (see Section 2 of this handbook to determine your project's risk level and if you are subject to these requirements). Many types of batch plant materials, including mortar, concrete, cement and block and their associated wastes have basic chemical properties that can raise pH levels outside of the permitted range. Additional care should be taken when managing these materials to prevent them from coming into contact with stormwater flows which may cause an exceedance of the General Permit requirements.

Suitable Applications

These procedures typically apply to construction sites where temporary batch plant facilities are used; however, some of the

Categories

EC	Erosion Control	
SE	Sediment Control	
TC	Tracking Control	
WE	Wind Erosion Control	
NS	Non-Stormwater Management Control	<input checked="" type="checkbox"/>
WM	Waste Management and Materials Pollution Control	

Legend:

- Primary Category
- Secondary Category

Targeted Constituents

Sediment	<input checked="" type="checkbox"/>
Nutrients	
Trash	<input checked="" type="checkbox"/>
Metals	<input checked="" type="checkbox"/>
Bacteria	
Oil and Grease	
Organics	

Potential Alternatives

None

If User/Subscriber modifies this fact sheet in any way, the CASQA name/logo and footer below must be removed from each page and not appear on the modified version.



practices described are applicable to construction sites with general concrete use.

Limitations

The General Permit for discharges of stormwater associated with industrial activities (General Industrial Permit) may be applicable to temporary batch plants.

Specific permit requirements or mitigation measures such as Air Resources Board (ARB), Air Quality Management District (AQMD), Air Pollution Control District (APCD, Regional Water Quality Control Board (RWQCB), county ordinances and city ordinances may require alternative mitigation measures for temporary batch plants. Contact the local regulatory agencies to determine if a permit is required.

Implementation

Planning

- Temporary batch plants may be subject to the General Industrial Permit. To obtain a copy of this permit and the application forms, visit <http://www.waterboards.ca.gov> or contact the State Water Resources Control Board.
- Proper planning, design, and construction of temporary batch plants should be implemented to minimize potential water quality, air pollution, and noise impacts associated with temporary batch plants.
- BMPs and a Construction Site Monitoring Plan (CSMP) should be included in the project Stormwater Pollution Prevention Plan (SWPPP). BMPs should be implemented, inspected, and maintained in accordance with these plans.
- Temporary batch plants should be managed to comply with AQMD Statewide Registration Program and/or local AQMD Portable Equipment Registration requirements.
- Construct temporary batch plants downwind of existing developments whenever possible.
- Placement of access roads should be planned to mitigate water and air quality impacts.

Layout and Design

- Temporary batch plants should be properly located and designed to mitigate water quality impacts to receiving water bodies. Batch plants should be located away from watercourses, drainage courses, and drain inlets. Batch plants should be located to minimize the potential for stormwater runoff onto the site.
- Temporary batch plant facilities (including associated stationary equipment and stockpiles) should be located at least 300 ft from any recreational area, school, residence, or other structure not associated with the construction project.
- Construct continuous interior AC or PCC berms around batch plant equipment (mixing equipment, silos, concrete drop points, conveyor belts, admixture tanks, etc.) to facilitate proper containment and cleanup of releases. Rollover or flip top curbs or dikes should be placed at ingress and egress points (SE-12, Temporary Silt Dike).
- Direct runoff from the paved or unpaved portion of the batch plant into a sump and pipe to a lined washout area or dewatering tank.

- Direct stormwater and non-stormwater runoff from unpaved portions of batch plant facility to catchment ponds or tanks.
- Construct and remove concrete washout facilities in accordance with WM-8, Concrete Waste Management.
- Layout of a typical batch plant and associated BMP is located at the end of this BMP fact sheet.

Operational Procedures

- Washout of concrete trucks should be conducted in a designated area in accordance with WM-8, Concrete Waste Management.
- Do not dispose of concrete into drain inlets, the stormwater drainage system, or watercourses.
- Washing of concrete mixing and transport equipment (including concrete truck washout) should occur in a designated area in accordance with WM-8, Concrete Waste Management.
- Washing equipment, tools, or vehicles to remove PCC should be conducted in accordance with NS-7, Potable Water/Irrigation, NS-8, Vehicle and Equipment Cleaning, and WM-8, Concrete Waste Management..
- All dry material transfer points should be ducted through a fabric or cartridge type filter unless there are no visible emissions from the transfer point.
- Equip all bulk storage silos, including auxiliary bulk storage trailers, with fabric or cartridge type filter(s).
- Maintain silo vent filters in proper operating condition.
- Equip silos and auxiliary bulk storage trailers with dust-tight service hatches.
- Fabric dust collection system should be capable of controlling particulate matter in accordance with the California Air Resources Control Board and local Air Pollution Control District Regulations.
- Fabric dust collectors (except for vent filters) should be equipped with an operational pressure differential gauge to measure the pressure drop across the filters.
- All transfer points should be equipped with a wet suppression system to control fugitive particulate emissions unless there are no visible emissions.
- All conveyors should be covered, unless the material being transferred results in no visible emissions.
- There should be no visible emissions beyond the property line, while the equipment is being operated.
- Collect dust emissions from the loading of open-bodied trucks, at the drip point of dry batch plants, or dust emissions from the drum feed for central mix plants.

- Equip silos and auxiliary bulk storage trailers with a visible and/or audible warning mechanism to warn operators that the silo or trailer is full.
- All open-bodied vehicles transporting material should be loaded with a final layer of wet sand and the truck should be covered with a tarp to reduce emissions.

Tracking Control

- Plant roads (batch truck and material delivery truck roads) and areas between stockpiles and conveyor hoppers should be stabilized (TC-2, Stabilized Construction Roadway), watered, treated with dust-suppressant chemicals (WE-1, Wind Erosion Control), or paved with a cohesive hard surface that can be repeatedly swept, maintained intact, and cleaned as necessary to control dust emissions.
- Trucks should not track PCC from plants onto public roads. Use appropriate practices from TC-1, Stabilized Construction Entrance/Exit, to prevent tracking.

Materials Storage

- WM-1, Material Delivery and Storage, should be implemented at all batch plants using concrete components or compounds. An effective strategy is to cover and contain materials.
- WM-2, Material Use should be conducted in a way to minimize or eliminate the discharge of materials to storm drain system or watercourse.
- Ensure that finer materials are not dispersed into the air during operations, such as unloading of cement delivery trucks.
- Stockpiles should be covered and enclosed with perimeter sediment barriers per WM-3, Stockpile Management. Uncovered stockpiles should be sprayed with water and/or dust-suppressant chemicals as necessary to control dust emissions, unless the stockpiled material results in no visible emissions. An operable stockpile watering system should be onsite at all times.
- Store bagged and boxed materials on pallets and cover or store in a completely enclosed storage area on non-working days and prior to rain.
- Minimize stockpiles of demolished PCC by recycling them in a timely manner.
- Provide secondary containment for liquid materials (WM-1, Material Delivery and Storage, WM-10, Liquid Waste Management). Containment should provide sufficient volume to contain precipitation from a 25-year storm plus 10% of the aggregate volume of all containers or plus 100% of the largest container, whichever is greater.
- Handle solid and liquid waste in accordance with WM-5, Solid Waste Management, WM-10, Liquid Waste Management, and WM-8, Concrete Waste Management.
- Maintain adequate supplies of spill cleanup materials and train staff to respond to spills per WM-4, Spill Prevention and Control.
- Immediately contain and clean up spilled cement and fly ash and contain.

Equipment Maintenance

- Equipment should be maintained to prevent fluid leaks and spills per NS-9, Vehicle and Equipment Fueling, and NS-10, Vehicle and Equipment Maintenance.
- Maintain adequate supplies of spill cleanup materials and train staff to respond to spills per WM-4, Spill Prevention and Control.
- Incorporate other BMPs such as WM-5, Solid Waste Management, WM-6, Hazardous Waste Management, and WM-10, Liquid Waste Management.

Costs

Costs will vary depending on the size of the facility and combination of BMPs implemented.

Inspection and Maintenance

- Inspect and verify that activity-based BMPs are in place prior to the commencement of associated activities.
- BMPs must be inspected in accordance with General Permit requirements for the associated project type and risk level. It is recommended that at a minimum, BMPs be inspected weekly, prior to forecasted rain events, daily during extended rain events, and after the conclusion of rain events.
- Inspect BMPs subject to non-stormwater discharge daily while non-stormwater discharges occur.
- Sample non-stormwater discharges and stormwater runoff that contacts cementitious materials or fly ash as required by the General Permit.
- Inspect and repair equipment (for damaged hoses, fittings, and gaskets).
- Inspect and maintain a Stabilized Construction Entrance/Exit (TC-1) as needed.
- Inspect and maintain stabilized haul roads as needed (TC-2, Stabilized Construction Roadway).
- Inspect and maintain materials and waste storage areas as needed.

References

Stormwater Quality Handbooks - Construction Site Best Management Practices (BMPs) Manual, State of California Department of Transportation (Caltrans), March 2003.

Stormwater Management for Construction Activities, Developing Pollution Prevention Plans and Best Management Practices, EPA 832-R-92005; USEPA, April 1992.

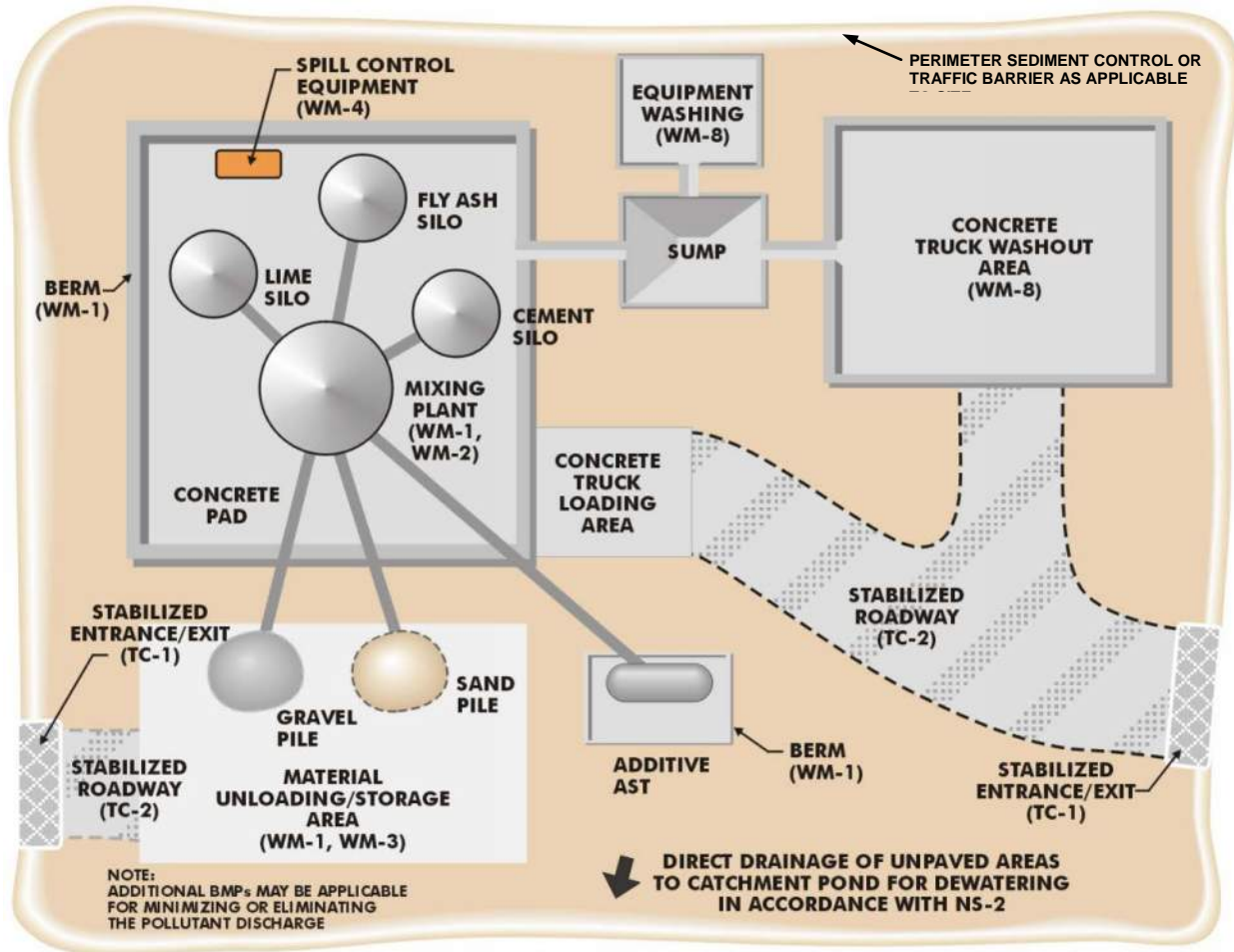

Typical Temporary Batch

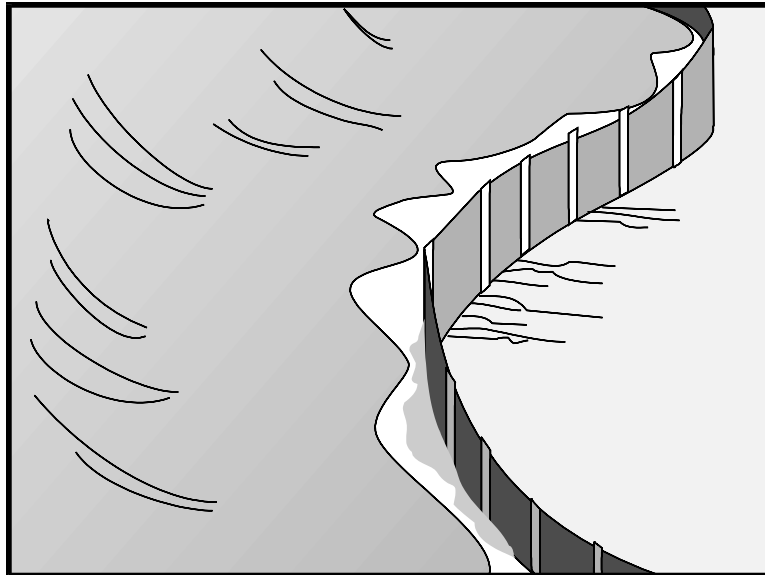

Description and Purpose

A silt fence is made of a woven geotextile that has been entrenched, attached to supporting poles, and sometimes backed by a plastic or wire mesh for support. The silt fence detains water, promoting sedimentation of coarse sediment behind the fence. Silt fence does not retain soil fine particles like clays or silts.

Suitable Applications

Silt fences are suitable for perimeter control, placed below areas where sheet flows discharge from the site. They could also be used as interior controls below disturbed areas where runoff may occur in the form of sheet and rill erosion and around inlets within disturbed areas (SE-10). Silt fences should not be used in locations where the flow is concentrated. Silt fences should always be used in combination with erosion controls. Suitable applications include:

- At perimeter of a project.
- Below the toe or down slope of exposed and erodible slopes.
- Along streams and channels.
- Around temporary spoil areas and stockpiles.
- Around inlets.
- Below other small cleared areas.

Categories

EC	Erosion Control	
SE	Sediment Control	<input checked="" type="checkbox"/>
TC	Tracking Control	
WE	Wind Erosion Control	
NS	Non-Stormwater Management Control	
WM	Waste Management and Materials Pollution Control	

Legend:

- Primary Category
- Secondary Category

Targeted Constituents

Sediment (coarse sediment)	<input checked="" type="checkbox"/>
Nutrients	
Trash	
Metals	
Bacteria	
Oil and Grease	
Organics	

Potential Alternatives

- SE-5 Fiber Rolls
- SE-6 Gravel Bag Berm
- SE-12 Manufactured Linear Sediment Controls
- SE-13 Compost Socks and Berms
- SE-14 Biofilter Bags

If User/Subscriber modifies this fact sheet in any way, the CASQA name/logo and footer below must be removed from each page and not appear on the modified version.



Limitations

- Do not use in streams, channels, drain inlets, or anywhere flow is concentrated.
- Do not use in locations where ponded water may cause a flooding hazard.
- Do not use silt fence to divert water flows or place across any contour line.
- Improperly installed fences are subject to failure from undercutting, overtopping, or collapsing.
- Must be trenched and keyed in.
- Not intended for use as a substitute for Fiber Rolls (SE-5), when fiber rolls are being used as a slope interruption device.
- Do not use on slopes subject to creeping, slumping, or landslides.

Implementation

General

A silt fence is a temporary sediment barrier consisting of woven geotextile stretched across and attached to supporting posts, trenched-in, and, depending upon the strength of fabric used, supported with plastic or wire mesh fence. Silt fences trap coarse sediment by intercepting and detaining sediment-laden runoff from disturbed areas in order to promote sedimentation behind the fence.

The following layout and installation guidance can improve performance and should be followed:

- Silt fence should be used in combination with erosion controls up-slope in order to provide the most effective sediment control.
- Silt fence alone is not effective at reducing turbidity. (Barrett and Malina, 2004)
- Designers should consider diverting sediment laden water to a temporary sediment basin or trap. (EPA, 2012)
- Use principally in areas where sheet flow occurs.
- Install along a level contour, so water does not pond more than 1.5 ft at any point along the silt fence.
- Provide sufficient room for runoff to pond behind the fence and to allow sediment removal equipment to pass between the silt fence and toes of slopes or other obstructions. About 1200 ft² of ponding area should be provided for every acre draining to the fence.
- Efficiency of silt fences is primarily dependent on the detention time of the runoff behind the control. (Barrett and Malina, 2004)
- The drainage area above any fence should not exceed a quarter of an acre. (Rule of Thumb- 100-feet of silt fence per 10,000 square feet of disturbed area.) (EPA 2012)

- The maximum length of slope draining to any point along the silt fence should be 100 ft per foot of silt fence.
- Turn the ends of the filter fence uphill to prevent stormwater from flowing around the fence.
- Leave an undisturbed or stabilized area immediately down slope from the fence where feasible.
- Silt fences should remain in place until the disturbed area draining to the silt fence is permanently stabilized, after which, the silt fence fabric and posts should be removed and properly disposed.
- J-Hooks, which have ends turning up the slope to break up long runs of fence and provide multiple storage areas that work like mini-retention areas, may be used to increase the effectiveness of silt fence.
- Be aware of local regulations regarding the type and installation requirements of silt fence, which may differ from those presented in this fact sheet.

Design and Layout

In areas where high winds are anticipated the fence should be supported by a plastic or wire mesh. The geotextile fabric of the silt fence should contain ultraviolet inhibitors and stabilizers to provide longevity equivalent to the project life or replacement schedule.

- Layout in accordance with the attached figures.
- For slopes that contain a high number of rocks or large dirt clods that tend to dislodge, it may be necessary to protect silt fence from rocks (e.g., rockfall netting) ensure the integrity of the silt fence installation.

Standard vs. Heavy Duty Silt Fence

Standard Silt Fence

- Generally applicable in cases where the area draining to fence produces moderate sediment loads.

Heavy Duty Silt Fence

- Heavy duty silt fence usually has 1 or more of the following characteristics, not possessed by standard silt fence.
 - Fabric is reinforced with wire backing or additional support.
 - Posts are spaced closer than pre-manufactured, standard silt fence products.
- Use is generally limited to areas affected by high winds.
- Area draining to fence produces moderate sediment loads.

Materials

Standard Silt Fence

- Silt fence material should be woven geotextile with a minimum width of 36 in. The fabric should conform to the requirements in ASTM designation D6461.
- Wooden stakes should be commercial quality lumber of the size and shape shown on the plans. Each stake should be free from decay, splits or cracks longer than the

thickness of the stake or other defects that would weaken the stakes and cause the stakes to be structurally unsuitable.

- Staples used to fasten the fence fabric to the stakes should be not less than 1.75 in. long and should be fabricated from 15 gauge or heavier wire. The wire used to fasten the tops of the stakes together when joining two sections of fence should be 9 gauge or heavier wire. Galvanizing of the fastening wire will not be required.

Heavy-Duty Silt Fence

- Some silt fence has a wire backing to provide additional support, and there are products that may use prefabricated plastic holders for the silt fence and use metal posts instead of wood stakes.

Installation Guidelines – Traditional Method

Silt fences are to be constructed on a level contour. Sufficient area should exist behind the fence for ponding to occur without flooding or overtopping the fence.

- A trench should be excavated approximately 6 in. wide and 6 in. deep along the line of the proposed silt fence (trenches should not be excavated wider or deeper than necessary for proper silt fence installation).
- Bottom of the silt fence should be keyed-in a minimum of 12 in.
- Posts should be spaced a maximum of 6 ft apart and driven securely into the ground a minimum of 18 in. or 12 in. below the bottom of the trench.
- When standard strength geotextile is used, a plastic or wire mesh support fence should be fastened securely to the upslope side of posts using heavy-duty wire staples at least 1 in. long. The mesh should extend into the trench.
- When extra-strength geotextile and closer post spacing are used, the mesh support fence may be eliminated.
- Woven geotextile should be purchased in a long roll, then cut to the length of the barrier. When joints are necessary, geotextile should be spliced together only at a support post, with a minimum 6 in. overlap and both ends securely fastened to the post.
- The trench should be backfilled with native material and compacted.
- Construct the length of each reach so that the change in base elevation along the reach does not exceed 1/3 the height of the barrier; in no case should the reach exceed 500 ft.
- Cross barriers should be a minimum of 1/3 and a maximum of 1/2 the height of the linear barrier.
- See typical installation details at the end of this fact sheet.

Installation Guidelines - Static Slicing Method

- Static Slicing is defined as insertion of a narrow blade pulled behind a tractor, similar to a plow blade, at least 10 inches into the soil while at the same time pulling silt geotextile fabric into the ground through the opening created by the blade to the depth of the blade. Once the geotextile is installed, the soil is compacted using tractor tires.
- This method will not work with pre-fabricated, wire backed silt fence.
- Benefits:
 - Ease of installation (most often done with a 2 person crew).
 - Minimal soil disturbance.
 - Better level of compaction along fence, less susceptible to undercutting
 - Uniform installation.
- Limitations:
 - Does not work in shallow or rocky soils.
 - Complete removal of geotextile material after use is difficult.
 - Be cautious when digging near potential underground utilities.

Costs

- It should be noted that costs vary greatly across regions due to available supplies and labor costs.
- Average annual cost for installation using the traditional silt fence installation method (assumes 6 month useful life) is \$7 per linear foot based on vendor research. Range of cost is \$3.50 - \$9.10 per linear foot.

Inspection and Maintenance

- BMPs must be inspected in accordance with General Permit requirements for the associated project type and risk level. It is recommended that at a minimum, BMPs be inspected weekly, prior to forecasted rain events, daily during extended rain events, and after the conclusion of rain events.
- Repair undercut silt fences.
- Repair or replace split, torn, slumping, or weathered fabric. The lifespan of silt fence fabric is generally 5 to 8 months.
- Silt fences that are damaged and become unsuitable for the intended purpose should be removed from the site of work, disposed, and replaced with new silt fence barriers.
- Sediment that accumulates in the BMP should be periodically removed in order to maintain BMP effectiveness. Sediment should be removed when the sediment accumulation reaches 1/3 of the barrier height.
- Silt fences should be left in place until the upgradient area is permanently stabilized. Until then, the silt fence should be inspected and maintained regularly.

- Remove silt fence when upgradient areas are stabilized. Fill and compact post holes and anchor trench, remove sediment accumulation, grade fence alignment to blend with adjacent ground, and stabilize disturbed area.

References

Manual of Standards of Erosion and Sediment Control Measures, Association of Bay Area Governments, May 1995.

Monitoring Data on Effectiveness of Sediment Control Techniques, Proceedings of World Water and Environmental Resources Congress, Barrett M. and Malina J. 2004.

National Management Measures to Control Nonpoint Source Pollution from Urban Areas, United States Environmental Protection Agency, 2002.

Proposed Guidance Specifying Management Measures for Sources of Nonpoint Pollution in Coastal Waters, Work Group-Working Paper, USEPA, April 1992.

Sedimentation and Erosion Control Practices, and Inventory of Current Practices (Draft), USEPA, 1990.

Southeastern Wisconsin Regional Planning Commission (SWRPC). Costs of Urban Nonpoint Source Water Pollution Control Measures. Technical Report No. 31. Southeastern Wisconsin Regional Planning Commission, Waukesha, WI. 1991.

Stormwater Quality Handbooks - Construction Site Best Management Practices (BMPs) Manual, State of California Department of Transportation (Caltrans), March 2003.

Stormwater Management Manual for The Puget Sound Basin, Washington State Department of Ecology, Public Review Draft, 1991.

U.S. Environmental Protection Agency (USEPA). Stormwater Best Management Practices: Silt Fences. U.S. Environmental Protection Agency, Office of Water, Washington, DC, 2012.

U.S. Environmental Protection Agency (USEPA). Stormwater Management for Industrial Activities: Developing Pollution Prevention Plans and Best Management Practices. U.S. Environmental Protection Agency, Office of Water, Washington, DC, 1992.

Water Quality Management Plan for the Lake Tahoe Region, Volume II, Handbook of Management Practices, Tahoe Regional Planning Agency, November 1988.

Soil Stabilization BMP Research for Erosion and Sediment Controls: Cost Survey Technical Memorandum, State of California Department of Transportation (Caltrans), July 2007.

Erosion and Sediment Control Manual, Oregon Department of Environmental Quality, February 2005.

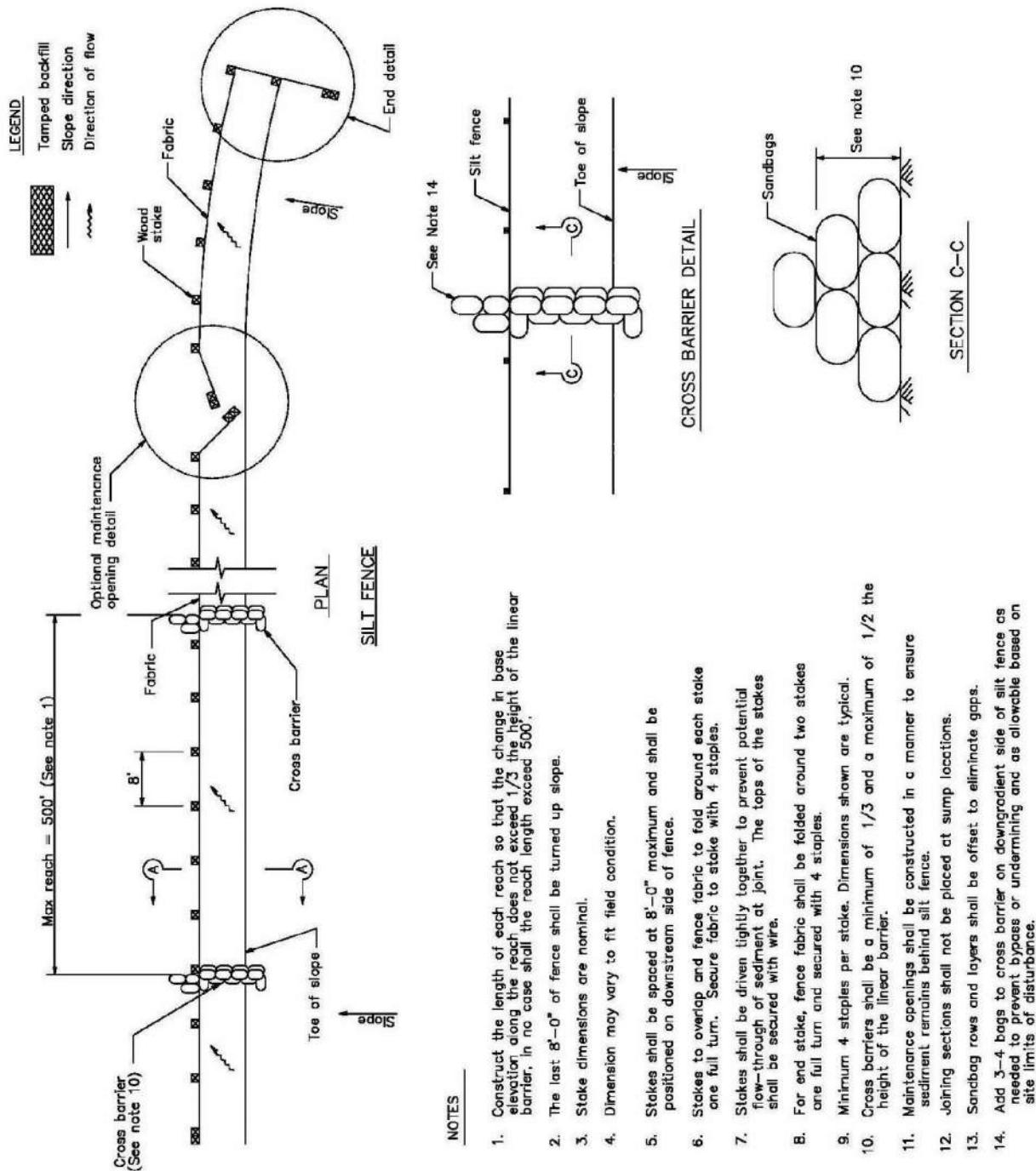

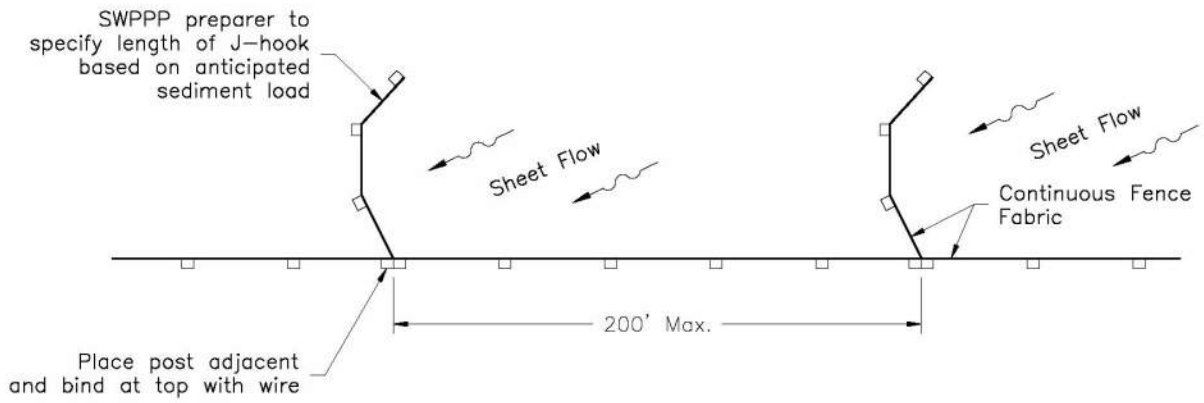

Plan

J-HOOK

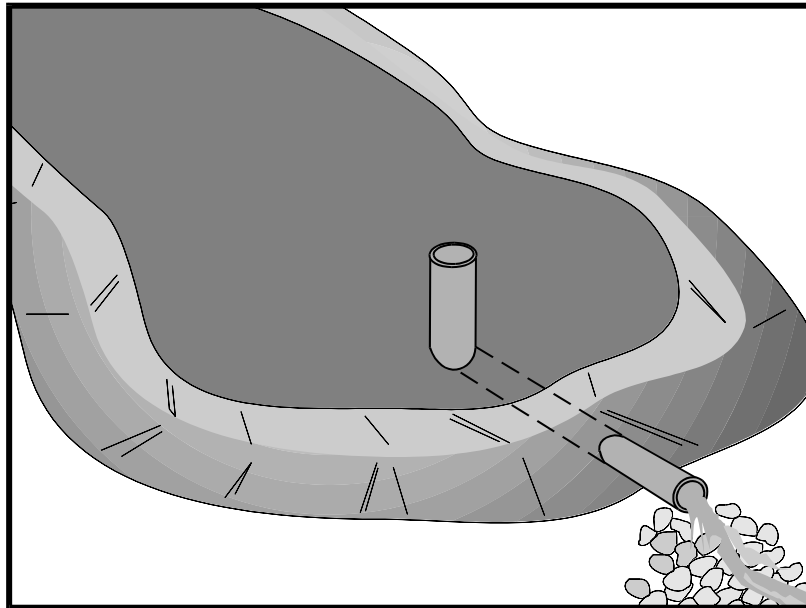

Description and Purpose

A sediment basin is a temporary basin formed by excavation or by constructing an embankment so that sediment-laden runoff is temporarily detained under quiescent conditions, allowing sediment to settle out before the runoff is released.

Sediment basin design guidance presented in this fact sheet is intended to provide options, methods, and techniques to optimize temporary sediment basin performance and basin sediment removal. Basin design guidance provided in this fact sheet is not intended to guarantee basin effluent compliance with numeric discharge limits (numeric action levels or numeric effluent limits for turbidity). Compliance with discharge limits requires a thoughtful approach to comprehensive BMP planning, implementation, and maintenance. Therefore, optimally designed and maintained sediment basins should be used in conjunction with a comprehensive system of BMPs that includes:

- Diverting runoff from undisturbed areas away from the basin
- Erosion control practices to minimize disturbed areas on-site and to provide temporary stabilization and interim sediment controls (e.g., stockpile perimeter control, check dams, perimeter controls around individual lots) to reduce the basin's influent sediment concentration.

At some sites, sediment basin design enhancements may be required to adequately remove sediment. Traditional

Categories

EC	Erosion Control	
SE	Sediment Control	<input checked="" type="checkbox"/>
TC	Tracking Control	
WE	Wind Erosion Control	
NS	Non-Stormwater Management Control	
WM	Waste Management and Materials Pollution Control	

Legend:

- Primary Category
- Secondary Category

Targeted Constituents

Sediment	<input checked="" type="checkbox"/>
Nutrients	
Trash	<input checked="" type="checkbox"/>
Metals	
Bacteria	
Oil and Grease	
Organics	

Potential Alternatives

SE-3 Sediment Trap (for smaller areas)

If User/Subscriber modifies this fact sheet in any way, the CASQA name/logo and footer below must be removed from each page and not appear on the modified version.



(a.k.a. “physical”) enhancements such as alternative outlet configurations or flow deflection baffles increase detention time and other techniques such as outlet skimmers preferentially drain flows with lower sediment concentrations. These “physical” enhancement techniques are described in this fact sheet. To further enhance sediment removal particularly at sites with fine soils or turbidity sensitive receiving waters, some projects may need to consider implementing Active Treatment Systems (ATS) whereby coagulants and flocculants are used to enhance settling and removal of suspended sediments. Guidance on implementing ATS is provided in SE-11.

Suitable Applications

Sediment basins may be suitable for use on larger projects with sufficient space for constructing the basin. Sediment basins should be considered for use:

- Where sediment-laden water may enter the drainage system or watercourses
- On construction projects with disturbed areas during the rainy season
- At the outlet of disturbed watersheds between 5 acres and 75 acres and evaluated on a site by site basis
- Where post construction detention basins are required
- In association with dikes, temporary channels, and pipes used to convey runoff from disturbed areas

Limitations

Sediment basins must be installed only within the property limits and where failure of the structure will not result in loss of life, damage to homes or buildings, or interruption of use or service of public roads or utilities. In addition, sediment basins are attractive to children and can be very dangerous. Local ordinances regarding health and safety must be adhered to. If fencing of the basin is required, the type of fence and its location should be shown in the SWPPP and in the construction specifications.

- As a general guideline, sediment basins are suitable for drainage areas of 5 acres or more, but not appropriate for drainage areas greater than 75 acres. However, the tributary area should be evaluated on a site by site basis.
- Sediment basins may become an “attractive nuisance” and care must be taken to adhere to all safety practices. If safety is a concern, basin may require protective fencing.
- Sediment basins designed according to this fact sheet are only effective in removing sediment down to about the silt size fraction. Sediment-laden runoff with smaller size fractions (fine silt and clay) may not be adequately treated unless chemical (or other appropriate method) treatment is used in addition to the sediment basin.
- Basins with a height of 25 ft or more or an impounding capacity of 50 ac-ft or more must obtain approval from California Department of Water Resources Division of Safety of Dams (<http://www.water.ca.gov/damsafety/>).

- Water that stands in sediment basins longer than 96 hours may become a source of mosquitoes (and midges), particularly along perimeter edges, in shallow zones, in scour or below-grade pools, around inlet pipes, along low-flow channels, and among protected habitats created by emergent or floating vegetation (e.g. cattails, water hyacinth), algal mats, riprap, etc.
- Basins require large surface areas to permit settling of sediment. Size may be limited by the available area.

Implementation

General

A sediment basin is a controlled stormwater release structure formed by excavation or by construction of an embankment of compacted soil across a drainage way, or other suitable location. It is intended to trap sediment before it leaves the construction site. The basin is a temporary measure expected to be used during active construction in most cases and is to be maintained until the site area is permanently protected against erosion or a permanent detention basin is constructed.

Sediment basins are suitable for nearly all types of construction projects. Whenever possible, construct the sediment basins before clearing and grading work begins. Basins should be located at the stormwater outlet from the site but not in any natural or undisturbed stream. A typical application would include temporary dikes, pipes, and/or channels to convey runoff to the basin inlet.

Many development projects in California are required by local ordinances to provide a stormwater detention basin for post-construction flood control, desilting, or stormwater pollution control. A temporary sediment basin may be constructed by rough grading the post-construction control basins early in the project.

Sediment basins if properly designed and maintained can trap a significant amount of the sediment that flows into them. However, traditional basins do not remove all inflowing sediment. Therefore, they should be used in conjunction with erosion control practices such as temporary seeding, mulching, diversion dikes, etc., to reduce the amount of sediment flowing into the basin.

Planning

To improve the effectiveness of the basin, it should be located to intercept runoff from the largest possible amount of disturbed area. Locations best suited for a sediment basin are generally in lower elevation areas of the site (or basin tributary area) where site drainage would not require significant diversion or other means to direct water to the basin but outside jurisdictional waterways. However, as necessary, drainage into the basin can be improved by the use of earth dikes and drainage swales (see BMP EC-9). . The basin should not be located where its failure would result in the loss of life or interruption of the use or service of public utilities or roads.

Construct before clearing and grading work begins when feasible.

- Do not locate the basin in a jurisdictional stream.

- Basin sites should be located where failure of the structure will not cause loss of life, damage to homes or buildings, or interruption of use or service of public roads or utilities.
- Basins with a height of 25 ft or more or an impounding capacity of 50 ac-ft must obtain approval from the Division of Dam Safety. Local dam safety requirements may be more stringent.
- Limit the contributing area to the sediment basin to only the runoff from the disturbed soil areas. Use temporary concentrated flow conveyance controls to divert runoff from undisturbed areas away from the sediment basin.
- The basin should be located: (1) by excavating a suitable area or where a low embankment can be constructed across a swale, (2) where post-construction (permanent) detention basins will be constructed, and (3) where the basins can be maintained on a year-round basis to provide access for maintenance, including sediment removal and sediment stockpiling in a protected area, and to maintain the basin to provide the required capacity.

Design

When designing a sediment basin, designers should evaluate the site constraints that could affect the efficiency of the BMP. Some of these constraints include: the relationship between basin capacity, anticipated sediment load, and freeboard, available footprint for the basin, maintenance frequency and access, and hydraulic capacity and efficiency of the temporary outlet infrastructure. Sediment basins should be designed to maximize sediment removal and to consider sediment load retained by the basin as it affects basin performance.

Three Basin Design Options (Part A) are presented below along with a Typical Sediment/Retention Basin Design Methodology (Part B). Regardless of the design option that is selected, designers also need to evaluate the sediment basin capacity with respect to sediment accumulation (See “*Step 3. Evaluate the Capacity of the Sediment Basin*”), and should incorporate approaches identified in “*Step 4. Other Design Considerations*” to enhance basin performance.

A) Basin Design Options:

Option 1:

Design sediment basin(s) using the standard equation:

$$A_s = \frac{1.2Q}{V_s} \quad (\text{Eq. 1})$$

Where:

A_s = Minimum surface area for trapping soil particles of a certain size

V_s = Settling velocity of the design particle size chosen ($V_s = 0.00028$ ft/s for a design particle size of 0.01 mm at 68°F)

1.2 = Factor of safety recommended by USEPA to account for the reduction in basin efficiency caused due to turbulence and other non ideal conditions.

$$Q = CIA \quad (\text{Eq.2})$$

Where

Q = Peak basin influent flow rate measured in cubic feet per second (ft³/s)

C = Runoff coefficient (unitless)

I = Peak rainfall intensity for the 10-year, 6-hour rain event (in/hr)

A = Area draining into the sediment basin in acres

The design particle size should be the smallest soil grain size determined by wet sieve analysis, or the fine silt sized (0.01 mm [or 0.0004 in.]) particle, and the Vs used should be 100 percent of the calculated settling velocity.

This sizing basin method is dependent on the outlet structure design or the total basin length with an appropriate outlet. If the designer chooses to utilize the outlet structure to control the flow duration in the basin, the basin length (distance between the inlet and the outlet) should be a minimum of twice the basin width; the depth should not be less than 3 ft nor greater than 5 ft for safety reasons and for maximum efficiency (2 ft of sediment storage, 2 ft of capacity). If the designer chooses to utilize the basin length (with appropriate basin outlet) to control the flow duration in the basin, the basin length (distance between the inlet and the outlet) should be a specifically designed to capture 100% of the design particle size; the depth should not be less than 3 ft nor greater than 5 ft for safety reasons and for maximum efficiency (2 ft of sediment storage, 2 ft of capacity).

Basin design guidance provided herein assumes standard water properties (e.g., estimated average water temperature, kinematic viscosity, etc.) as a basis of the design. Designers can use an alternative design (Option 3) with site specific water properties as long as the design is as protective as Option 1.

The design guidance uses the peak influent flow rate to size sediment basins. Designers can use an alternative design (Option 3) with site specific average flow rates as long as the design is as protective as Option 1.

The basin should be located on the site where it can be maintained on a year-round basis and should be maintained on a schedule to retain the 2 ft of capacity.

Option 2:

Design pursuant to local ordinance for sediment basin design and maintenance, provided that the design efficiency is as protective or more protective of water quality than Option 1.

Option 3:

The use of an equivalent surface area design or equation provided that the design efficiency is as protective or more protective of water quality than Option 1.

B) Typical Sediment/Detention Basin Design Methodology:

Design of a sediment basin requires the designer to have an understanding of the site constraints, knowledge of the local soil (e.g., particle size distribution of potentially contributing soils), drainage area of the basin, and local hydrology. Designers should not assume that a sediment basin for location A is applicable to location B. Therefore, designers can use this factsheet as guidance but will need to apply professional judgment and knowledge of the site to design an effective and efficient sediment basin. The following provides a general overview of typical design methodologies:

Step 1. Hydrologic Design

- Evaluate the site constraints and assess the drainage area for the sediment basin. Designers should consider on- and off-site flows as well as changes in the drainage area associated with site construction/disturbance. To minimize additional construction during the course of the project, the designer should consider identifying the maximum drainage area when calculating the basin dimensions.
- If a local hydrology manual is not available it is recommended to follow standard rational method procedures to estimate the flow rate. The references section of this factsheet provides a reference to standard hydrology textbooks that can provide standard methodologies. If local rainfall depths are not available, values can be obtained from standard precipitation frequency maps from NOAA (downloaded from <http://www.wrcc.dri.edu/pcpnfreq.html>).

Step 2. Hydraulic Design

- Calculate the surface area required for the sediment basin using Equation 1. In which the flow rate is estimated for a 10-yr 6-hr event using rational method procedure listed in local hydrology manual and V_s is estimated using Stokes Law presented in Equation 3.

$$V_s = 2.81d^2 \quad (\text{Eq.3})$$

Where

V_s = Settling velocity in feet per second at 68°F

d = diameter of sediment particle in millimeters (smallest soil grain size determined by wet sieve analysis or fine silt (0.01 mm [or 0.0004 in.]

- In general the basin outlet design requires an iterative trial and error approach that considered the maximum water surface elevation, the elevation versus volume (stage-storage) relationship, the elevation versus basin outflow (a.k.a.-discharge) relationship, and the estimated inflow hydrograph. To adequately design the basins to settle sediment, the outlet configuration and associated outflow rates can be estimated by numerous methodologies. The following provides some guidance for design the basin outlet:
 - An outlet should have more than one orifice.
 - An outlet design typically utilizes multiple horizontal rows of orifices (approximately 3 or more) with at least 2 orifices per row (see Figures 1 and 2 at the end of this fact sheet).

- Orifices can vary in shape.
- Select the appropriate orifice diameter and number of perforations per row with the objective of minimizing the number of rows while maximizing the detention time.
- The diameter of each orifice is typically a maximum of 3-4 inches and a minimum of 0.25-0.5 inches.
- If a rectangular orifice is used, it is recommended to have minimum height of 0.5 inches and a maximum height of 6 inches.
- Rows are typically spaced at three times the diameter center to center vertically with a minimum distance of approximately 4 inches on center and a maximum distance of 1 foot on center.
- To estimate the outflow rate, each row is calculated separately based on the flow through a single orifice then multiplied by the number of orifices in the row. This step is repeated for each of the rows. Once all of the orifices are estimated, the total outflow rate versus elevation (stage-discharge curve) is developed to evaluate the detention time within the basin.
- Flow through a single orifice can be estimated using an Equation 4:

$$Q = BC' A(2gH)^{0.5} \quad (\text{Eq.4})$$

Where

Q = Outflow rate in ft³/s

C' = Orifice coefficient (unitless)

A = Area of the orifice (ft²)

g = acceleration due to gravity (ft³/s)

H = Head above the orifice (ft)

B = Anticipated Blockage or clogging factor (unitless), It is dependent on anticipated sediment and debris load, trash rack configuration etc, so the value is dependent on design engineers professional judgment and/or local requirements (B is never greater than 1 and a value of 0.5 is generally used)

- Care must be taken in the selection of orifice coefficient ("C'"); 0.60 is most often recommended and used. However, based on actual tests, Young and Graziano (1989), "Outlet Hydraulics of Extended Detention Facilities for Northern Virginia Planning District Commission", recommends the following:
 - C' = 0.66 for thin materials; where the thickness is equal to or less than the orifice diameter, or
 - C' = 0.80 when the material is thicker than the orifice diameter
- If different sizes of orifices are used along the riser then they have to be sized such that not more than 50 percent of the design storm event drains in one-third of the drawdown time (to provide adequate settling time for events smaller than the design storm event)

and the entire volume drains within 96 hours or as regulated by the local vector control agency. If a basin fails to drain within 96 hours, the basin must be pumped dry.

- Because basins are not maintained for infiltration, water loss by infiltration should be disregarded when designing the hydraulic capacity of the outlet structure.
- **Floating Outlet Skimmer:** The floating skimmer (see Figure 3 at the end of this fact sheet is an alternative outlet configuration (patented) that drains water from upper portion of the water column. This configuration has been used for temporary and permanent basins and can improve basin performance by eliminating bottom orifices which have the potential of discharging solids. Some design considerations for this alternative outlet device includes the addition of a sand filter or perforated under drain at the low point in the basin and near the floating skimmer. These secondary drains allow the basin to fully drain. More detailed guidelines for sizing the skimmer can be downloaded from <http://www.fairclothskimmer.com/>.
- **Hold and Release Valve:** An ideal sediment/detention basin would hold all flows to the design storm level for sufficient time to settle solids, and then slowly release the storm water. Implementing a reliable valve system for releasing detention basins is critical to eliminate the potential for flooding in such a system. Some variations of hold and release valves include manual valves, bladder devices or electrically operated valves. When a precipitation event is forecast, the valve would be close for the duration of the storm and appropriate settling time. When the settling duration is met (approximately 24 or 48 hours), the valve would be opened and allow the stormwater to be released at a rate that does not resuspend settled solids and in a non-erosive manner. If this type of system is used the valve should be designed to empty the entire basin within 96 hours or as stipulated by local vector control regulations.

Step 3. Evaluate the Capacity of the Sediment Basin

- Typically, sediment basins do not perform as designed when they are not properly maintained or the sediment yield to the basin is larger than expected. As part of a good sediment basin design, designers should consider maintenance cycles, estimated soil loss and/or sediment yield, and basin sediment storage volume. The two equations below can be used to quantify the amount of soil entering the basin.
- The Revised Universal Soil Loss Equation (RUSLE, Eq.5) can be used to estimate annual soil loss and the Modified Universal Soil Equation (MUSLE, Eq.6) can be used to estimate sediment yield from a single storm event.

$$A = R \times K \times LS \times C \times P \quad (\text{Eq.5})$$

$$Y = 95 \left(Q \times q_p \right)^{0.56} \times K \times LS \times C \times P \quad (\text{Eq.6})$$

Where:

A = annual soil loss, tons/acre-year

R = rainfall erosion index, in 100 ft.tons/acre.in/hr

K = soil erodibility factor, tons/acre per unit of R

LS = slope length and steepness factor (unitless)

C = vegetative cover factor (unitless)

P = erosion control practice factor (unitless)

Y = single storm sediment yield in tons

Q = runoff volume in acre-feet

q_p = peak flow in cfs

- Detailed descriptions and methodologies for estimating the soil loss can be obtained from standard hydrology text books (See References section).
- Determination of the appropriate equation should consider construction duration and local environmental factors (soils, hydrology, etc.). For example, if a basin is planned for a project duration of 1 year and the designer specifies one maintenance cycle, RUSLE could be used to estimate the soil loss and thereby the designer could indicate that the sediment storage volume would be half of the soil loss value estimated. As an example for use of MUSLE, a project may have a short construction duration thereby requiring fewer maintenance cycles and a reduced sediment storage volume. MUSLE would be used to estimate the anticipated soil loss based on a specific storm event to evaluate the sediment storage volume and appropriate maintenance frequency.
- The soil loss estimates are an essential step in the design and it is essential that the designer provide construction contractors with enough information to understand maintenance frequency and/or depths within the basin that would trigger maintenance. Providing maintenance methods, frequency and specification should be included in design bid documents such as the SWPPP Site Map.
- Once the designer has quantified the amount of soil entering the basin, the depth required for sediment storage can be determined by dividing the estimated sediment loss by the surface area of the basin.

Step 4. Other Design Considerations

- Consider designing the volume of the settling zone for the total storm volume associated with the 2-year event or other appropriate design storms specified by the local agency. This volume can be used as a guide for sizing the basin without iterative routing calculations. The depth of the settling zone can be estimated by dividing the estimated 2-yr storm volume by the surface area of the basin.
- The basin volume consists of two zones:
 - A sediment storage zone at least 1 ft deep.
 - A settling zone at least 2 ft deep.

- The basin depth must be no less than 3 ft (not including freeboard).
- Proper hydraulic design of the outlet is critical to achieving the desired performance of the basin. The outlet should be designed to drain the basin within 24 to 96 hours (also referred to as “drawdown time”). The 24-hour limit is specified to provide adequate settling time; the 96-hour limit is specified to mitigate vector control concerns.
- Confirmation of the basin performance can be evaluated by routing the design storm (10-yr 6-hr, or as directed by local regulations) through the basin based on the basin volume (stage-storage curve) and the outlet design (stage-discharge curve based on the orifice configuration or equivalent outlet design).
- Sediment basins, regardless of size and storage volume, should include features to accommodate overflow or bypass flows that exceed the design storm event.
 - Include an emergency spillway to accommodate flows not carried by the principal spillway. The spillway should consist of an open channel (earthen or vegetated) over undisturbed material (not fill) or constructed of a non-erodible riprap (or equivalent protection) on fill slopes.
 - The spillway control section, which is a level portion of the spillway channel at the highest elevation in the channel, should be a minimum of 20 ft in length.
- Rock, vegetation or appropriate erosion control should be used to protect the basin inlet, outlet, and slopes against erosion.
- The total depth of the sediment basin should include the depth required for sediment storage, depth required for settling zone and freeboard of at least 1 foot or as regulated by local flood control agency for a flood event specified by the local agency.
- The basin alignment should be designed such that the length of the basin is more than twice the width of the basin; the length should be determined by measuring the distance between the inlet and the outlet. If the site topography does not allow for this configuration baffles should be installed so that the ratio is satisfied. If a basin has more than one inflow point, any inflow point that conveys more than 30 percent of the total peak inflow rate has to meet the required length to width ratio.
- An alternative basin sizing method proposed by Fifield (2004) can be consulted to estimate an alternative length to width ratio and basin configuration. These methods can be considered as part of Option 3 which allows for alternative designs that are protective or more protective of water quality.
- Baffles (see Figure 4 at the end of this fact sheet) can be considered at project sites where the existing topography or site constraints limit the length to width ratio. Baffles should be constructed of earthen berms or other structural material within the basin to divert flow in the basin, thus increasing the effective flow length from the basin inlet to the outlet riser. Baffles also reduce the change of short circuiting and allows for settling throughout the basin.

- Baffles are typically constructed from the invert of the basin to the crest of the emergency spillway (i.e., design event flows are meant to flow around the baffles and flows greater than the design event would flow over the baffles to the emergency spillway).
- Use of other materials for construction of basin baffles (such as silt fence) may not be appropriate based on the material specifications and will require frequent maintenance (maintain after every storm event). Maintenance may not be feasible when required due to flooded conditions resulting from frequent (i.e., back to back) storm events. Use of alternative baffle materials should not deviate from the intended purpose of the material, as described by the manufacturer.
- Sediment basins are best used in conjunction with erosion controls.
- Basins with an impounding levee greater than 4.5 ft tall, measured from the lowest point to the impounding area to the highest point of the levee, and basins capable of impounding more than 35,000 ft³, should be designed by a Registered Civil Engineer. The design should include maintenance requirements, including sediment and vegetation removal, to ensure continuous function of the basin outlet and bypass structures.
- A forebay, constructed upstream of the basin, may be provided to remove debris and larger particles.
- The outflow from the sediment basin should be provided with velocity dissipation devices (see BMP EC-10) to prevent erosion and scouring of the embankment and channel.
- The principal outlet should consist of a corrugated metal, high density polyethylene (HDPE), or reinforced concrete riser pipe with dewatering holes and an anti-vortex device and trash rack attached to the top of the riser, to prevent floating debris from flowing out of the basin or obstructing the system. This principal structure should be designed to accommodate the inflow design storm.
- A rock pile or rock-filled gabions can serve as alternatives to the debris screen, although the designer should be aware of the potential for extra maintenance involved should the pore spaces in the rock pile clog.
- The outlet structure should be placed on a firm, smooth foundation with the base securely anchored with concrete or other means to prevent floatation.
- Attach riser pipe (watertight connection) to a horizontal pipe (barrel). Provide anti-seep collars on the barrel.
- Cleanout level should be clearly marked on the riser pipe.

Installation

- Securely anchor and install an anti-seep collar on the outlet pipe/riser and provide an emergency spillway for passing major floods (see local flood control agency).
- Areas under embankments must be cleared and stripped of vegetation.

- Chain link fencing should be provided around each sediment basin to prevent unauthorized entry to the basin or if safety is a concern.

Costs

The cost of a sediment basin is highly variable and is dependent of the site configuration. To decrease basin construction costs, designers should consider using existing site features such as berms or depressed area to site the sediment basin. Designers should also consider potential savings associated with designing the basin to minimize the number of maintenance cycles and siting the basin in a location where a permanent BMP (e.g., extended detention basin) is required for the project site.

Inspection and Maintenance

- BMPs must be inspected in accordance with General Permit requirements for the associated project type and risk level and as required by local requirements. It is recommended that at a minimum, basins be inspected weekly, prior to forecasted rain events, daily during extended rain events, and after the conclusion of rain events.
- Examine basin banks for seepage and structural soundness.
- Check inlet and outlet structures and spillway for any damage or obstructions. Repair damage and remove obstructions as needed.
- Check inlet and outlet area for erosion and stabilize if required.
- Check fencing for damage and repair as needed.
- Sediment that accumulates in the basin must be periodically removed in order to maintain BMP effectiveness. Sediment should be removed when sediment accumulation reaches one-half the designated sediment storage volume. Sediment removed during maintenance should be managed properly. The sediment should be appropriately evaluated and used or disposed of accordingly. Options include: incorporating sediment into earthwork on the site (only if there is no risk that sediment is contaminated); or off-site export/disposal at an appropriate location (e.g., sediment characterization and disposal to an appropriate landfill).
- Remove standing water from basin within 96 hours after accumulation.
- If the basin does not drain adequately (e.g., due to storms that are more frequent or larger than the design storm or other unforeseen site conditions), dewatering should be conducted in accordance with appropriate dewatering BMPs (see NS-2) and in accordance with local permits as applicable.
- To minimize vector production:
 - Remove accumulation of live and dead floating vegetation in basins during every inspection.
 - Remove excessive emergent and perimeter vegetation as needed or as advised by local or state vector control agencies.

References

A Current Assessment of Urban Best Management Practices: Techniques for Reducing Nonpoint Source Pollution in the Coastal Zones, Metropolitan Washington Council of Governments, March 1992.

Draft-Sedimentation and Erosion Control, an Inventory of Current Practices, USEPA. April 1990.

U.S. Environmental Protection Agency (USEPA). Erosion and Sediment Control, Surface Mining in the Eastern U.S., U.S. Environmental Protection Agency, Office of Water, Washington, DC, Washington, D.C., 1976.

Fifield, J.S. Designing for Effective Sediment and Erosion Control on Construction Sites. Forester Press, Santa Barbara, CA. 2004.

Goldman S.J., Jackson K. and Bursztynsky T.A. Erosion and Sediment Control Handbook. McGraw-Hill Book Company, 1986.

U.S. Environmental Protection Agency (USEPA). Guidance Specifying Management Measures for Nonpoint Pollution in Coastal Waters. EPA 840-B-9-002. U.S. Environmental Protection Agency, Office of Water, Washington, DC, 1993.

Guidelines for the Design and Construction of Small Embankment Dams, Division of Safety of Dams, California Department of Water Resources, March 1986.

Haan C.T., Barfield B.J. and Hayes J.C. Design Hydrology and Sedimentology for Small Catchments. Academic Press. 1994.

Inlet/Outlet Alternatives for Extended Detention Basins. State of California Department of Transportation (Caltrans), 2001.

Manual of Standards of Erosion and Sediment Control Measures, Association of Bay Area Governments, May 1995.

McLean, J., 2000. Mosquitoes in Constructed Wetlands: A Management Bugaboo? In T.R. Schueler and H.K. Holland [eds.], The Practice of Watershed Protection. pp. 29-33. Center for Watershed Protection, Ellicott City, MD, 2000.

Metzger, M.E., D. F. Messer, C. L. Beitia, C. M. Myers, and V. L. Kramer. The Dark Side of Stormwater Runoff Management: Disease Vectors Associated with Structural BMPs, 2002.

National Management Measures to Control Nonpoint Source Pollution from Urban Areas, United States Environmental Protection Agency, 2002.

Proposed Guidance Specifying Management Measures for Sources of Nonpoint Pollution in Coastal Water, Work Group-Working Paper, USEPA, April 1992.

Stormwater Management of the Puget Sound Basin, Technical Manual, Publication #91-75, Washington State Department of Ecology, February 1992.

Stormwater Quality Handbooks - Construction Site Best Management Practices (BMPs) Manual, State of California Department of Transportation (Caltrans), November 2000.

Water Quality Management Plan for the Lake Tahoe Region, Volume II Handbook of Management Practices, Tahoe Regional Planning Agency, November 1988.

Young, G.K. and Graziano, F., Outlet Hydraulics of Extended Detention Facilities for Northern Virginia Planning District Commission, 1989.

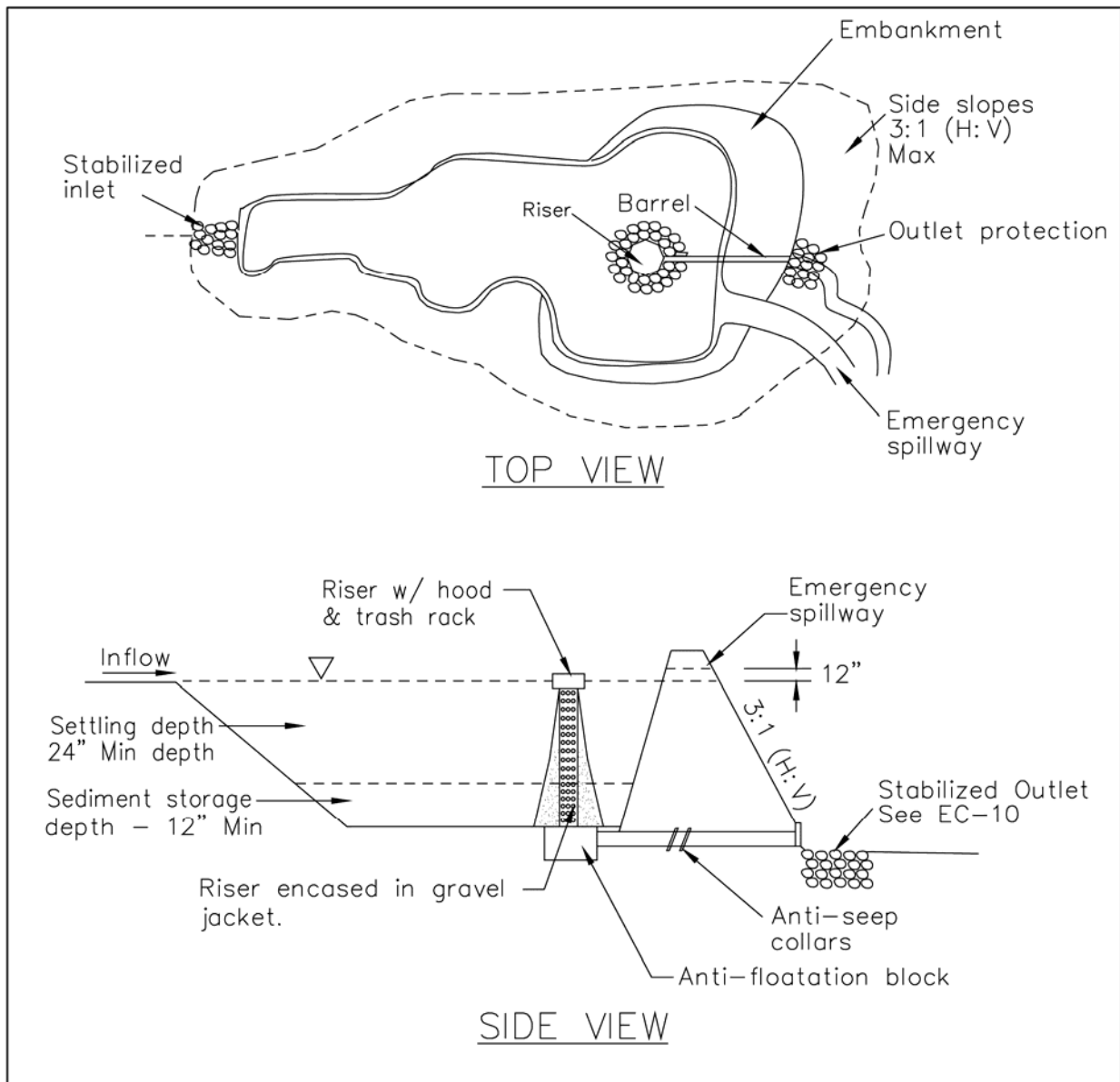

**FIGURE 1: TYPICAL TEMPORARY SEDIMENT BASIN
 MULTIPLE ORIFICE DESIGN
 NOT TO SCALE**

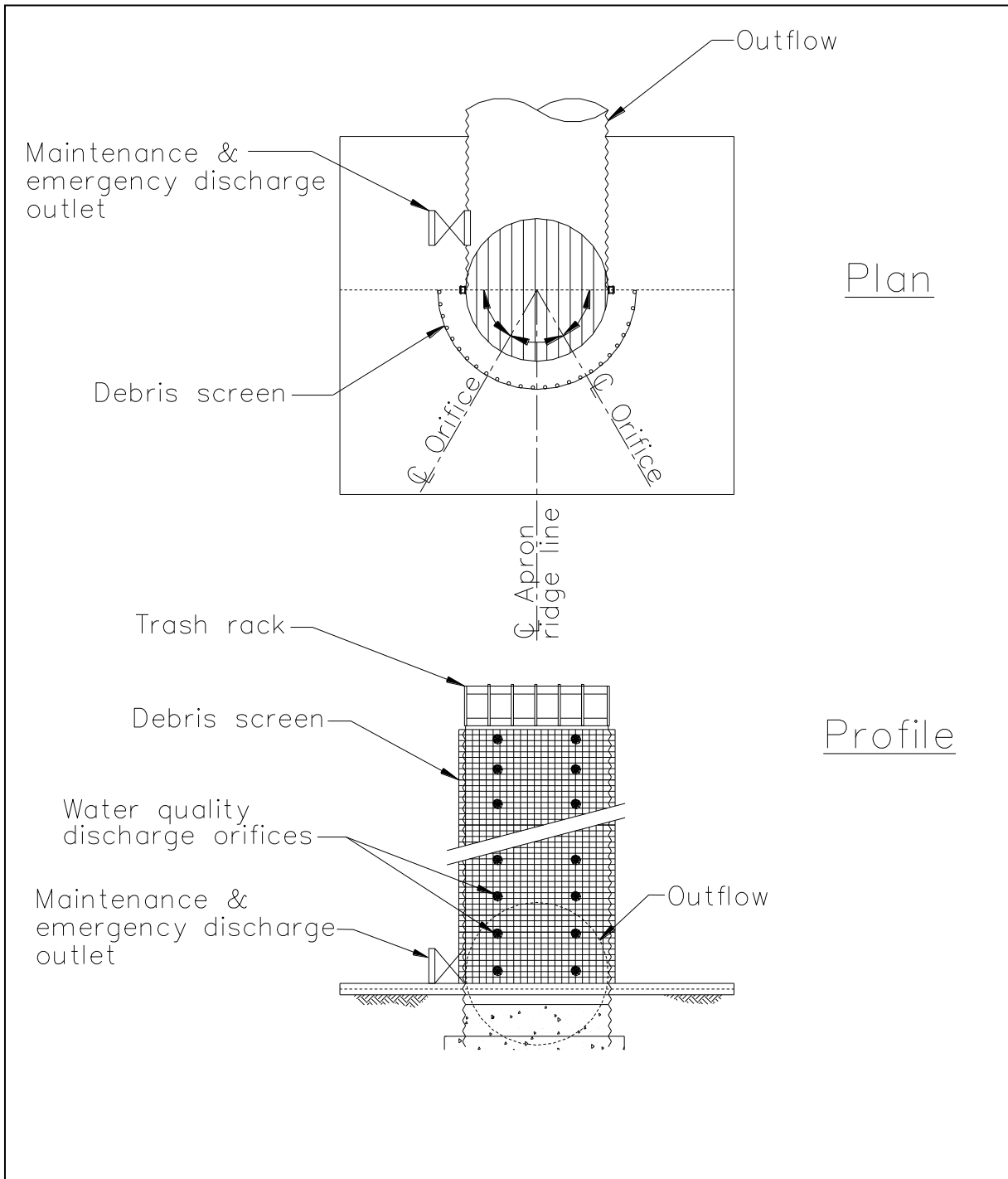

FIGURE 2: MULTIPLE ORIFICE OUTLET RISER
NOT TO SCALE

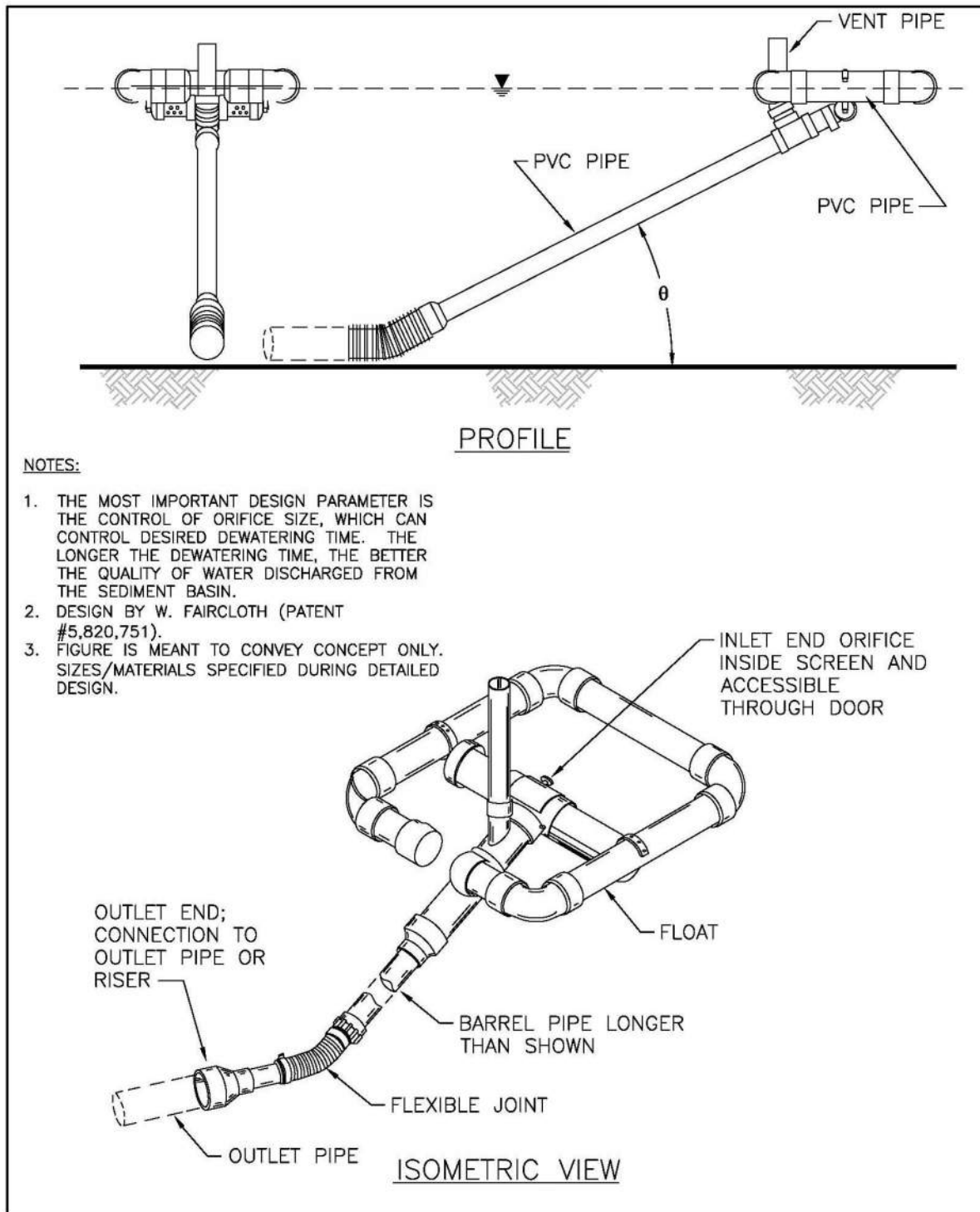

FIGURE 3: TYPICAL SKIMMER

NOT TO SCALE

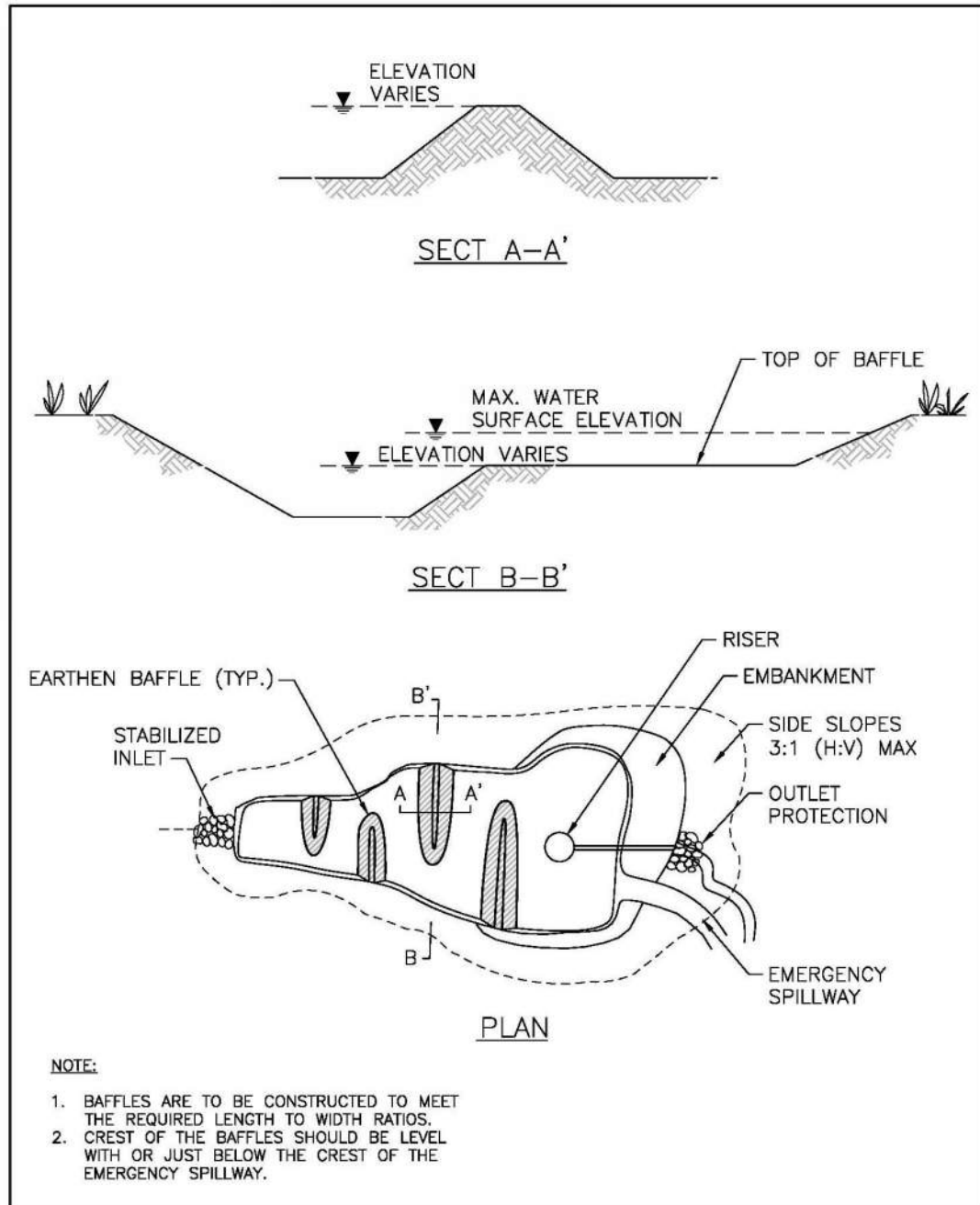
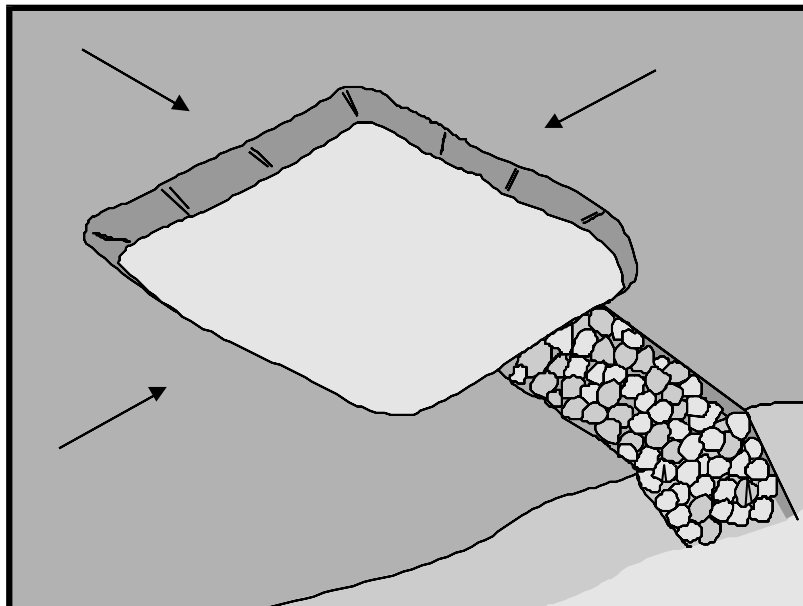

FIGURE 4: TYPICAL TEMPORARY SEDIMENT BASIN WITH BAFFLES
NOT TO SCALE



Description and Purpose

A sediment trap is a containment area where sediment-laden runoff is temporarily detained under quiescent conditions, allowing sediment to settle out or before the runoff is discharged by gravity flow. Sediment traps are formed by excavating or constructing an earthen embankment across a waterway or low drainage area.

Trap design guidance provided in this fact sheet is not intended to guarantee compliance with numeric discharge limits (numeric action levels or numeric effluent limits for turbidity). Compliance with discharge limits requires a thoughtful approach to comprehensive BMP planning, implementation, and maintenance. Therefore, optimally designed and maintained sediment traps should be used in conjunction with a comprehensive system of BMPs.

Suitable Applications

Sediment traps should be considered for use:

- At the perimeter of the site at locations where sediment-laden runoff is discharged offsite.
- At multiple locations within the project site where sediment control is needed.
- Around or upslope from storm drain inlet protection measures.
- Sediment traps may be used on construction projects where the drainage area is less than 5 acres. Traps would be

Categories

EC	Erosion Control	
SE	Sediment Control	<input checked="" type="checkbox"/>
TC	Tracking Control	
WE	Wind Erosion Control	
NS	Non-Stormwater Management Control	
WM	Waste Management and Materials Pollution Control	

Legend:

- Primary Objective
- Secondary Objective

Targeted Constituents

Sediment	<input checked="" type="checkbox"/>
Nutrients	
Trash	<input checked="" type="checkbox"/>
Metals	
Bacteria	
Oil and Grease	
Organics	

Potential Alternatives

SE-2 Sediment Basin (for larger areas)

If User/Subscriber modifies this fact sheet in any way, the CASQA name/logo and footer below must be removed from each page and not appear on the modified version.



placed where sediment-laden stormwater may enter a storm drain or watercourse. SE-2, Sediment Basins, must be used for drainage areas greater than 5 acres.

- As a supplemental control, sediment traps provide additional protection for a water body or for reducing sediment before it enters a drainage system.

Limitations

- Requires large surface areas to permit infiltration and settling of sediment.
- Not appropriate for drainage areas greater than 5 acres.
- Only removes large and medium sized particles and requires upstream erosion control.
- Attractive and dangerous to children, requiring protective fencing.
- Conducive to vector production.
- Should not be located in live streams.

Implementation

Design

A sediment trap is a small temporary ponding area, usually with a gravel outlet, formed by excavation or by construction of an earthen embankment. Its purpose is to collect and store sediment from sites cleared or graded during construction. It is intended for use on small drainage areas with no unusual drainage features and projected for a quick build-out time. It should help in removing coarse sediment from runoff. The trap is a temporary measure with a design life of approximately six months to one year and is to be maintained until the site area is permanently protected against erosion by vegetation and/or structures.

Sediment traps should be used only for small drainage areas. If the contributing drainage area is greater than 5 acres, refer to SE-2, Sediment Basins, or subdivide the catchment area into smaller drainage basins.

Sediment usually must be removed from the trap after each rainfall event. The SWPPP should detail how this sediment is to be disposed, such as in fill areas onsite, or removal to an approved offsite dump. Sediment traps used as perimeter controls should be installed before any land disturbance takes place in the drainage area.

Sediment traps are usually small enough that a failure of the structure would not result in a loss of life, damage to home or buildings, or interruption in the use of public roads or utilities. However, sediment traps are attractive to children and can be dangerous. The following recommendations should be implemented to reduce risks:

- Install continuous fencing around the sediment trap or pond. Consult local ordinances regarding requirements for maintaining health and safety.
- Restrict basin side slopes to 3:1 or flatter.

Sediment trap size depends on the type of soil, size of the drainage area, and desired sediment removal efficiency (see SE-2, Sediment Basin). As a rule of thumb, the larger the basin volume

the greater the sediment removal efficiency. Sizing criteria are typically established under the local grading ordinance or equivalent. The runoff volume from a 2-year storm is a common design criteria for a sediment trap. The sizing criteria below assume that this runoff volume is 0.042 acre-ft/acre (0.5 in. of runoff). While the climatic, topographic, and soil type extremes make it difficult to establish a statewide standard, the following criteria should trap moderate to high amounts of sediment in most areas of California:

- Locate sediment traps as near as practical to areas producing the sediment.
- Trap should be situated according to the following criteria: (1) by excavating a suitable area or where a low embankment can be constructed across a swale, (2) where failure would not cause loss of life or property damage, and (3) to provide access for maintenance, including sediment removal and sediment stockpiling in a protected area.
- Trap should be sized to accommodate a settling zone and sediment storage zone with recommended minimum volumes of 67 yd³/acre and 33 yd³/acre of contributing drainage area, respectively, based on 0.5 in. of runoff volume over a 24-hour period. In many cases, the size of an individual trap is limited by available space. Multiple traps or additional volume may be required to accommodate specific rainfall, soil, and site conditions.
- Traps with an impounding levee greater than 4.5 ft tall, measured from the lowest point to the impounding area to the highest point of the levee, and traps capable of impounding more than 35,000 ft³, should be designed by a Registered Civil Engineer. The design should include maintenance requirements, including sediment and vegetation removal, to ensure continuous function of the trap outlet and bypass structures.
- The outlet pipe or open spillway must be designed to convey anticipated peak flows.
- Use rock or vegetation to protect the trap outlets against erosion.
- Fencing should be provided to prevent unauthorized entry.

Installation

Sediment traps can be constructed by excavating a depression in the ground or creating an impoundment with a small embankment. Sediment traps should be installed outside the area being graded and should be built prior to the start of the grading activities or removal of vegetation. To minimize the area disturbed by them, sediment traps should be installed in natural depressions or in small swales or drainage ways. The following steps must be followed during installation:

- The area under the embankment must be cleared, grubbed, and stripped of any vegetation and root mat. The pool area should be cleared.
- The fill material for the embankment must be free of roots or other woody vegetation as well as oversized stones, rocks, organic material, or other objectionable material. The embankment may be compacted by traversing with equipment while it is being constructed.
- All cut-and-fill slopes should be 3:1 or flatter.
- When a riser is used, all pipe joints must be watertight.

- When a riser is used, at least the top two-thirds of the riser should be perforated with 0.5 in. diameter holes spaced 8 in. vertically and 10 to 12 in. horizontally. See SE-2, Sediment Basin.
- When an earth or stone outlet is used, the outlet crest elevation should be at least 1 ft below the top of the embankment.
- When crushed stone outlet is used, the crushed stone used in the outlet should meet AASHTO M43, size No. 2 or 24, or its equivalent such as MSHA No. 2. Gravel meeting the above gradation may be used if crushed stone is not available.

Costs

Average annual cost per installation and maintenance (18 month useful life) is \$0.73 per ft³ (\$1,300 per drainage acre). Maintenance costs are approximately 20% of installation costs.

Inspection and Maintenance

- Inspect BMPs in accordance with General Permit requirements for the associated project type and risk level. It is recommended that at a minimum, BMPs be inspected weekly, prior to forecasted rain events, daily during extended rain events, and after the conclusion of rain events.
- Inspect outlet area for erosion and stabilize if required.
- Inspect trap banks for seepage and structural soundness, repair as needed.
- Inspect outlet structure and spillway for any damage or obstructions. Repair damage and remove obstructions as needed.
- Inspect fencing for damage and repair as needed.
- Inspect the sediment trap for area of standing water during every visit. Corrective measures should be taken if the BMP does not dewater completely in 96 hours or less to prevent vector production.
- Sediment that accumulates in the BMP must be periodically removed in order to maintain BMP effectiveness. Sediment should be removed when the sediment accumulation reaches one-third of the trap capacity. Sediment removed during maintenance may be incorporated into earthwork on the site or disposed of at an appropriate location.
- Remove vegetation from the sediment trap when first detected to prevent pools of standing water and subsequent vector production.
- BMPs that require dewatering shall be continuously attended while dewatering takes place. Dewatering BMPs per NS-2 shall be implemented at all times during dewatering activities.

References

Brown, W., and T. Schueler. The Economics of Stormwater BMPs in the Mid-Atlantic Region. Prepared for Chesapeake Research Consortium, Edgewater, MD, by the Center for Watershed Protection, Ellicott City, MD, 1997.

Draft – Sedimentation and Erosion Control, an Inventory of Current Practices, USEPA, April 1990.

Manual of Standards of Erosion and Sediment Control Measures, Association of Bay Area Governments, May 1995.

Metzger, M.E., D.F. Messer, C.L. Beitia, C.M. Myers, and V.L. Kramer, The Dark Side of Stormwater Runoff Management: Disease Vectors Associated with Structural BMPs, 2002.

National Management Measures to Control Nonpoint Source Pollution from Urban Areas, United States Environmental Protection Agency, 2002.

Proposed Guidance Specifying Management Measures for Sources of Nonpoint Pollution in Coastal Waters, Work Group-Working Paper, USEPA, April 1992.

Stormwater Quality Handbooks - Construction Site Best Management Practices (BMPs) Manual, State of California Department of Transportation (Caltrans), November 2000.

Stormwater Management Manual for The Puget Sound Basin, Washington State Department of Ecology, Public Review Draft, 1991.

U.S. Environmental Protection Agency (USEPA). Guidance Specifying Management Measures for Nonpoint Pollution in Coastal Waters. EPA 840-B-9-002. U.S. Environmental Protection Agency, Office of Water, Washington, DC, 1993.

Water Quality Management Plan for the Lake Tahoe Region, Volume II, Handbook of Management Practices, Tahoe Regional Planning Agency, November 1988.

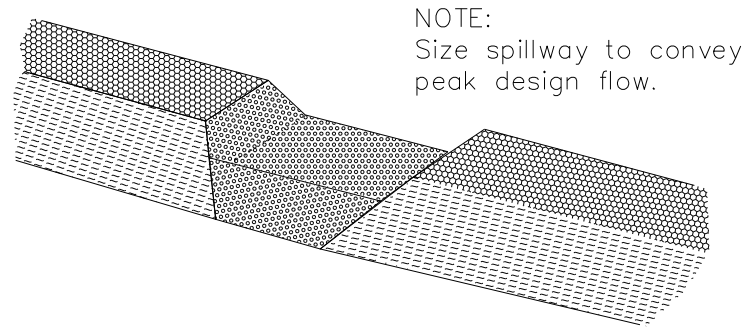

NOTE:
Size spillway to convey
peak design flow.

TYPICAL OPEN SPILLWAY

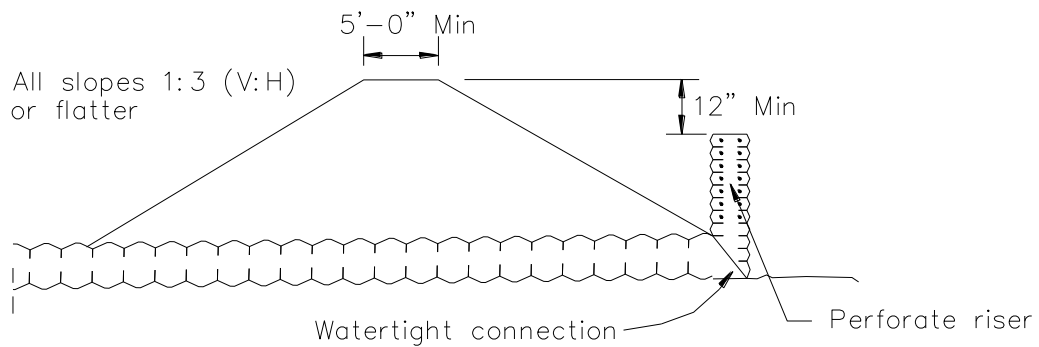
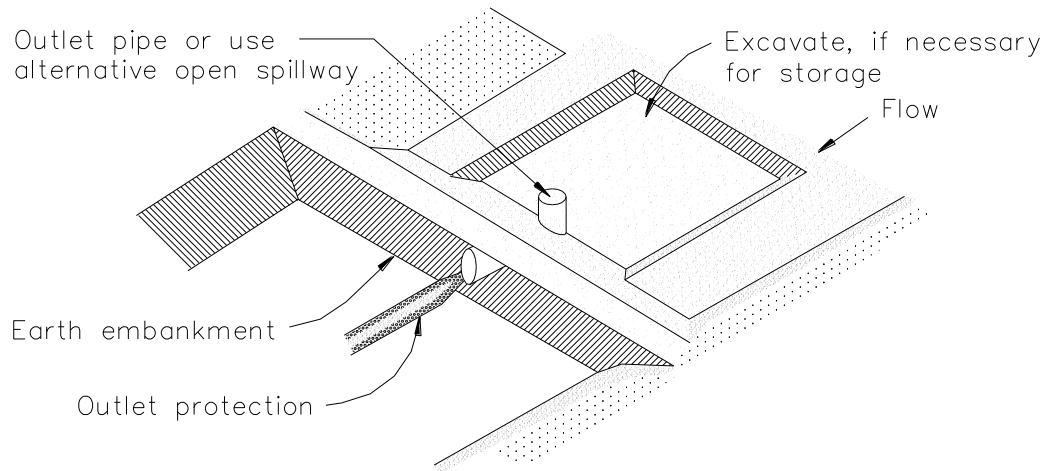

EMBANKMENT SECTION THRU RISER

TYPICAL SEDIMENT TRAP
NOT TO SCALE

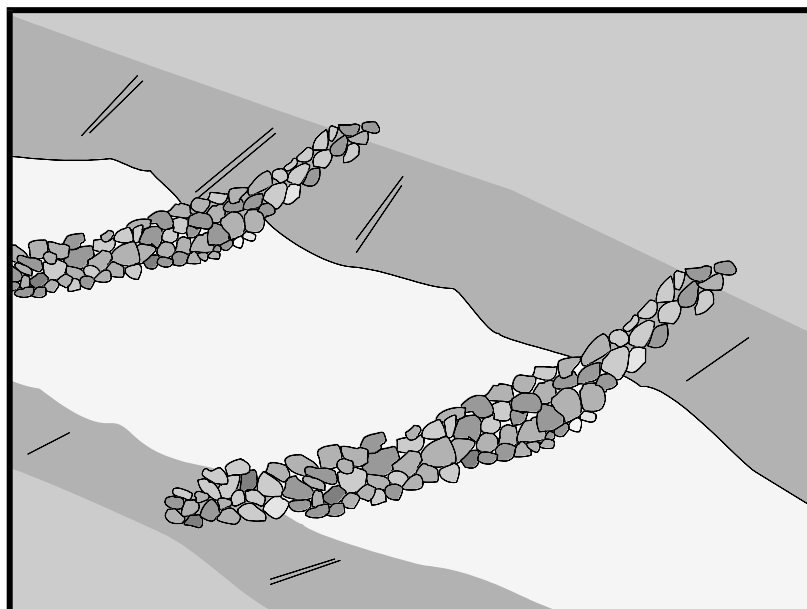

Description and Purpose

A check dam is a small barrier constructed of rock, gravel bags, sandbags, fiber rolls, or other proprietary products, placed across a constructed swale or drainage ditch. Check dams reduce the effective slope of the channel, thereby reducing scour and channel erosion by reducing flow velocity and increasing residence time within the channel, allowing sediment to settle.

Suitable Applications

Check dams may be appropriate in the following situations:

- To promote sedimentation behind the dam.
- To prevent erosion by reducing the velocity of channel flow in small intermittent channels and temporary swales.
- In small open channels that drain 10 acres or less.
- In steep channels where stormwater runoff velocities exceed 5 ft/s.
- During the establishment of grass linings in drainage ditches or channels.
- In temporary ditches where the short length of service does not warrant establishment of erosion-resistant linings.
- To act as a grade control structure.

Categories

EC	Erosion Control	<input checked="" type="checkbox"/>
SE	Sediment Control	<input checked="" type="checkbox"/>
TC	Tracking Control	
WE	Wind Erosion Control	
NS	Non-Stormwater Management Control	
WM	Waste Management and Materials Pollution Control	

Legend:

- Primary Category**
- Secondary Category**

Targeted Constituents

Sediment	<input checked="" type="checkbox"/>
Nutrients	
Trash	
Metals	
Bacteria	
Oil and Grease	
Organics	

Potential Alternatives

- SE-5 Fiber Rolls
- SE-6 Gravel Bag Berm
- SE-8 Sandbag Barrier
- SE-12 Manufactured Linear Sediment Controls
- SE-14 Biofilter Bags

If User/Subscriber modifies this fact sheet in any way, the CASQA name/logo and footer below must be removed from each page and not appear on the modified version.



Limitations

- Not to be used in live streams or in channels with extended base flows.
- Not appropriate in channels that drain areas greater than 10 acres.
- Not appropriate in channels that are already grass-lined unless erosion potential or sediment-laden flow is expected, as installation may damage vegetation.
- Require extensive maintenance following high velocity flows.
- Promotes sediment trapping which can be re-suspended during subsequent storms or removal of the check dam.
- Do not construct check dams with straw bales or silt fence.
- Water suitable for mosquito production may stand behind check dams, particularly if subjected to daily non-stormwater discharges.

Implementation

General

Check dams reduce the effective slope and create small pools in swales and ditches that drain 10 acres or less. Using check dams to reduce channel slope reduces the velocity of stormwater flows, thus reducing erosion of the swale or ditch and promoting sedimentation. Thus, check dams are dual-purpose and serve an important role as erosion controls as well as as sediment controls. Note that use of 1-2 isolated check dams for sedimentation will likely result in little net removal of sediment because of the small detention time and probable scour during longer storms. Using a series of check dams will generally increase their effectiveness. A sediment trap (SE-3) may be placed immediately upstream of the check dam to increase sediment removal efficiency.

Design and Layout

Check dams work by decreasing the effective slope in ditches and swales. An important consequence of the reduced slope is a reduction in capacity of the ditch or swale. This reduction in capacity should be considered when using this BMP, as reduced capacity can result in overtopping of the ditch or swale and resultant consequences. In some cases, such as a “permanent” ditch or swale being constructed early and used as a “temporary” conveyance for construction flows, the ditch or swale may have sufficient capacity such that the temporary reduction in capacity due to check dams is acceptable. When check dams reduce capacities beyond acceptable limits, either:

- Don't use check dams. Consider alternative BMPs, or.
- Increase the size of the ditch or swale to restore capacity.

Maximum slope and velocity reduction is achieved when the toe of the upstream dam is at the same elevation as the top of the downstream dam (see “Spacing Between Check Dams” detail at the end of this fact sheet). The center section of the dam should be lower than the edge sections (at least 6 inches), acting as a spillway, so that the check dam will direct flows to the center of

the ditch or swale (see “Typical Rock Check Dam” detail at the end of this fact sheet). Bypass or side-cutting can occur if a sufficient spillway is not provided in the center of the dam.

Check dams are usually constructed of rock, gravel bags, sandbags, and fiber rolls. A number of products can also be used as check dams (e.g. HDPE check dams, temporary silt dikes (SE-12)), and some of these products can be removed and reused. Check dams can also be constructed of logs or lumber, and have the advantage of a longer lifespan when compared to gravel bags, sandbags, and fiber rolls. Check dams should not be constructed from straw bales or silt fences, since concentrated flows quickly wash out these materials.

Rock check dams are usually constructed of 8 to 12 in. rock. The rock is placed either by hand or mechanically, but never just dumped into the channel. The dam should completely span the ditch or swale to prevent washout. The rock used should be large enough to stay in place given the expected design flow through the channel. It is recommended that abutments be extended 18 in. into the channel bank. Rock can be graded such that smaller diameter rock (e.g. 2-4 in) is located on the upstream side of larger rock (holding the smaller rock in place); increasing residence time.

Log check dams are usually constructed of 4 to 6 in. diameter logs, installed vertically. The logs should be embedded into the soil at least 18 in. Logs can be bolted or wired to vertical support logs that have been driven or buried into the soil.

See fiber rolls, SE-5, for installation of fiber roll check dams.

Gravel bag and sand bag check dams are constructed by stacking bags across the ditch or swale, shaped as shown in the drawings at the end of this fact sheet (see “Gravel Bag Check Dam” detail at the end of this fact sheet).

Manufactured products, such as temporary silt dikes (SE-12), should be installed in accordance with the manufacturer’s instructions. Installation typically requires anchoring or trenching of products, as well as regular maintenance to remove accumulated sediment and debris.

If grass is planted to stabilize the ditch or swale, the check dam should be removed when the grass has matured (unless the slope of the swales is greater than 4%).

The following guidance should be followed for the design and layout of check dams:

- Install the first check dam approximately 16 ft from the outfall device and at regular intervals based on slope gradient and soil type.
- Check dams should be placed at a distance and height to allow small pools to form between each check dam.
- For multiple check dam installation, backwater from a downstream check dam should reach the toes of the upstream check dam.
- A sediment trap provided immediately upstream of the check dam will help capture sediment. Due to the potential for this sediment to be resuspended in subsequent storms, the sediment trap should be cleaned following each storm event.

- High flows (typically a 2-year storm or larger) should safely flow over the check dam without an increase in upstream flooding or damage to the check dam.
- Where grass is used to line ditches, check dams should be removed when grass has matured sufficiently to protect the ditch or swale.

Materials

- Rock used for check dams should typically be 8-12 in rock and be sufficiently sized to stay in place given expected design flows in the channel. Smaller diameter rock (e.g. 2 to 4 in) can be placed on the upstream side of larger rock to increase residence time.
- Gravel bags used for check dams should conform to the requirements of SE-6, Gravel Bag Berms.
- Sandbags used for check dams should conform to SE-8, Sandbag Barrier.
- Fiber rolls used for check dams should conform to SE-5, Fiber Rolls.
- Temporary silt dikes used for check dams should conform to SE-12, Temporary Silt Dikes.

Installation

- Rock should be placed individually by hand or by mechanical methods (no dumping of rock) to achieve complete ditch or swale coverage.
- Tightly abut bags and stack according to detail shown in the figure at the end of this section (pyramid approach). Gravel bags and sandbags should not be stacked any higher than 3 ft.
- Upper rows of gravel and sand bags shall overlap joints in lower rows.
- Fiber rolls should be trenched in, backfilled, and firmly staked in place.
- Install along a level contour.
- HDPE check dams, temporary silt dikes, and other manufactured products should be used and installed per manufacturer specifications.

Costs

Cost consists of labor costs if materials are readily available (such as gravel on-site). If material must be imported, costs will increase. For other material and installation costs, see SE-5, SE-6, SE-8, SE-12, and SE-14.

Inspection and Maintenance

- BMPs must be inspected in accordance with General Permit requirements for the associated project type and risk level. It is recommended that at a minimum, BMPs be inspected weekly, prior to forecasted rain events, daily during extended rain events, and after the conclusion of rain events.
- Replace missing rock, bags, rolls, etc. Replace bags or rolls that have degraded or have become damaged.

- If the check dam is used as a sediment capture device, sediment that accumulates behind the BMP should be periodically removed in order to maintain BMP effectiveness. Sediment should be removed when the sediment accumulation reaches one-third of the barrier height.
- If the check dam is used as a grade control structure, sediment removal is not required as long as the system continues to control the grade.
- Inspect areas behind check dams for pools of standing water, especially if subjected to daily non-stormwater discharges.
- Remove accumulated sediment prior to permanent seeding or soil stabilization.
- Remove check dam and accumulated sediment when check dams are no longer needed.

References

Draft – Sedimentation and Erosion Control, and Inventory of Current Practices, USEPA, April 1990.

Manual of Standards of Erosion and Sediment Control Measures, Association of Bay Area Governments, May 1995.

Stormwater Quality Handbooks - Construction Site Best Management Practices (BMPs) Manual, State of California Department of Transportation (Caltrans), March 2003.

Stormwater Management of the Puget Sound Basin, Technical Manual, Publication #91-75, Washington State Department of Ecology, February 1992.

Erosion and Sediment Control Manual, Oregon Department of Environmental Quality, February 2005.

Metzger, M.E. 2004. Managing mosquitoes in stormwater treatment devices. University of California Division of Agriculture and Natural Resources, Publication 8125. On-line: <http://anrcatalog.ucdavis.edu/pdf/8125.pdf>

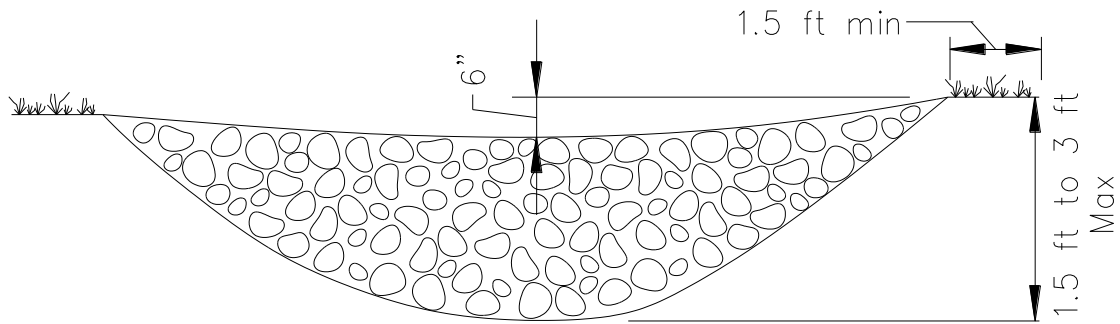

ELEVATION

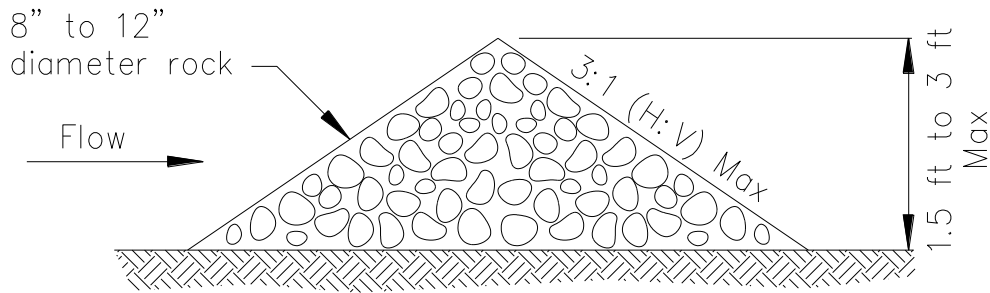

TYPICAL ROCK CHECK DAM SECTION

ROCK CHECK DAM
NOT TO SCALE

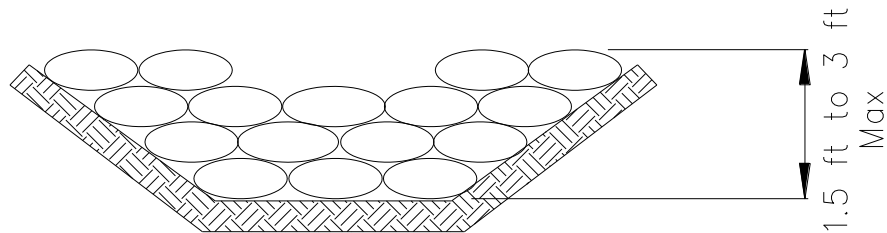

GRAVEL BAG CHECK DAM ELEVATION
NOT TO SCALE

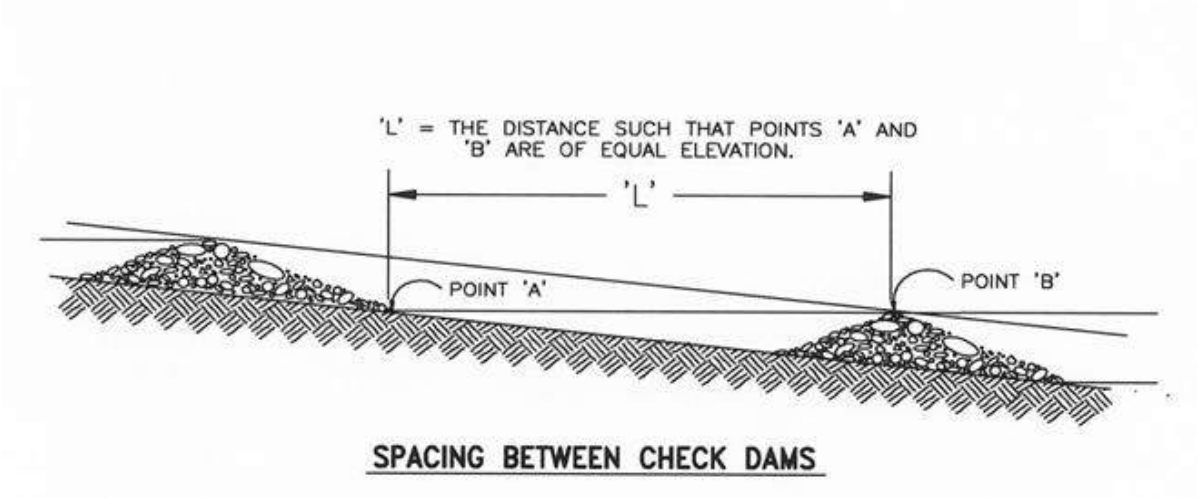

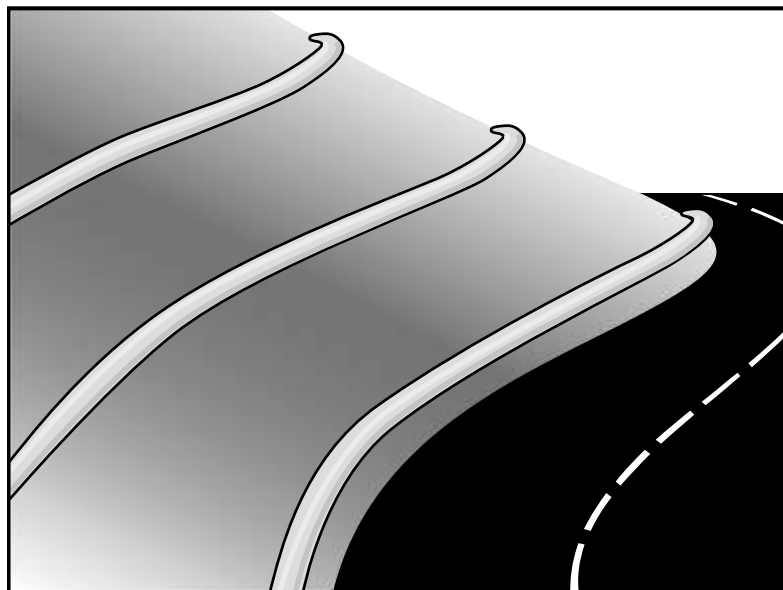

Description and Purpose

A fiber roll consists of straw, coir, or other biodegradable materials bound into a tight tubular roll wrapped by netting, which can be photodegradable or natural. Additionally, gravel core fiber rolls are available, which contain an imbedded ballast material such as gravel or sand for additional weight when staking the rolls are not feasible (such as use as inlet protection). When fiber rolls are placed at the toe and on the face of slopes along the contours, they intercept runoff, reduce its flow velocity, release the runoff as sheet flow, and provide removal of sediment from the runoff (through sedimentation). By interrupting the length of a slope, fiber rolls can also reduce sheet and rill erosion until vegetation is established.

Suitable Applications

Fiber rolls may be suitable:

- Along the toe, top, face, and at grade breaks of exposed and erodible slopes to shorten slope length and spread runoff as sheet flow.
- At the end of a downward slope where it transitions to a steeper slope.
- Along the perimeter of a project.
- As check dams in unlined ditches with minimal grade.
- Down-slope of exposed soil areas.
- At operational storm drains as a form of inlet protection.

Categories

EC	Erosion Control	<input checked="" type="checkbox"/>
SE	Sediment Control	<input checked="" type="checkbox"/>
TC	Tracking Control	
WE	Wind Erosion Control	
NS	Non-Stormwater Management Control	
WM	Waste Management and Materials Pollution Control	

Legend:

- Primary Category
- Secondary Category

Targeted Constituents

Sediment	<input checked="" type="checkbox"/>
Nutrients	
Trash	
Metals	
Bacteria	
Oil and Grease	
Organics	

Potential Alternatives

- SE-1 Silt Fence
- SE-6 Gravel Bag Berm
- SE-8 Sandbag Barrier
- SE-12 Manufactured Linear Sediment Controls
- SE-14 Biofilter Bags

If User/Subscriber modifies this fact sheet in any way, the CASQA name/logo and footer below must be removed from each page and not appear on the modified version.



- Around temporary stockpiles.

Limitations

- Fiber rolls are not effective unless trenched in and staked.
- Not intended for use in high flow situations.
- Difficult to move once saturated.
- If not properly staked and trenched in, fiber rolls could be transported by high flows.
- Fiber rolls have a very limited sediment capture zone.
- Fiber rolls should not be used on slopes subject to creep, slumping, or landslide.
- Rolls typically function for 12-24 months depending upon local conditions.

Implementation

Fiber Roll Materials

- Fiber rolls should be prefabricated.
- Fiber rolls may come manufactured containing polyacrylamide (PAM), a flocculating agent within the roll. Fiber rolls impregnated with PAM provide additional sediment removal capabilities and should be used in areas with fine, clayey or silty soils to provide additional sediment removal capabilities. Monitoring may be required for these installations.
- Fiber rolls are made from weed free rice straw, flax, or a similar agricultural material bound into a tight tubular roll by netting.
- Typical fiber rolls vary in diameter from 9 in. to 20 in. Larger diameter rolls are available as well.

Installation

- Locate fiber rolls on level contours spaced as follows:
 - Slope inclination of 4:1 (H:V) or flatter: Fiber rolls should be placed at a maximum interval of 20 ft.
 - Slope inclination between 4:1 and 2:1 (H:V): Fiber Rolls should be placed at a maximum interval of 15 ft. (a closer spacing is more effective).
 - Slope inclination 2:1 (H:V) or greater: Fiber Rolls should be placed at a maximum interval of 10 ft. (a closer spacing is more effective).
- Prepare the slope before beginning installation.
- Dig small trenches across the slope on the contour. The trench depth should be $\frac{1}{4}$ to $\frac{1}{3}$ of the thickness of the roll, and the width should equal the roll diameter, in order to provide area to backfill the trench.

- It is critical that rolls are installed perpendicular to water movement, and parallel to the slope contour.
- Start building trenches and installing rolls from the bottom of the slope and work up.
- It is recommended that pilot holes be driven through the fiber roll. Use a straight bar to drive holes through the roll and into the soil for the wooden stakes.
- Turn the ends of the fiber roll up slope to prevent runoff from going around the roll.
- Stake fiber rolls into the trench.
 - Drive stakes at the end of each fiber roll and spaced 4 ft maximum on center.
 - Use wood stakes with a nominal classification of 0.75 by 0.75 in. and minimum length of 24 in.
- If more than one fiber roll is placed in a row, the rolls should be overlapped, not abutted.
- See typical fiber roll installation details at the end of this fact sheet.

Removal

- Fiber rolls can be left in place or removed depending on the type of fiber roll and application (temporary vs. permanent installation). Typically, fiber rolls encased with plastic netting are used for a temporary application because the netting does not biodegrade. Fiber rolls used in a permanent application are typically encased with a biodegradable material and are left in place. Removal of a fiber roll used in a permanent application can result in greater disturbance.
- Temporary installations should only be removed when up gradient areas are stabilized per General Permit requirements, and/or pollutant sources no longer present a hazard. But, they should also be removed before vegetation becomes too mature so that the removal process does not disturb more soil and vegetation than is necessary.

Costs

Material costs for regular fiber rolls range from \$20 - \$30 per 25 ft roll.

Material costs for PAM impregnated fiber rolls range between 7.00-\$9.00 per linear foot, based upon vendor research.

Inspection and Maintenance

- BMPs must be inspected in accordance with General Permit requirements for the associated project type and risk level. It is recommended that at a minimum, BMPs be inspected weekly, prior to forecasted rain events, daily during extended rain events, and after the conclusion of rain events.
- Repair or replace split, torn, unraveling, or slumping fiber rolls.
- If the fiber roll is used as a sediment capture device, or as an erosion control device to maintain sheet flows, sediment that accumulates in the BMP should be periodically removed

in order to maintain BMP effectiveness. Sediment should be removed when sediment accumulation reaches one-third the designated sediment storage depth.

- If fiber rolls are used for erosion control, such as in a check dam, sediment removal should not be required as long as the system continues to control the grade. Sediment control BMPs will likely be required in conjunction with this type of application.
- Repair any rills or gullies promptly.

References

Stormwater Quality Handbooks - Construction Site Best Management Practices (BMPs) Manual, State of California Department of Transportation (Caltrans), March 2003.

Erosion and Sediment Control Manual, Oregon Department of Environmental Quality, February 2005.

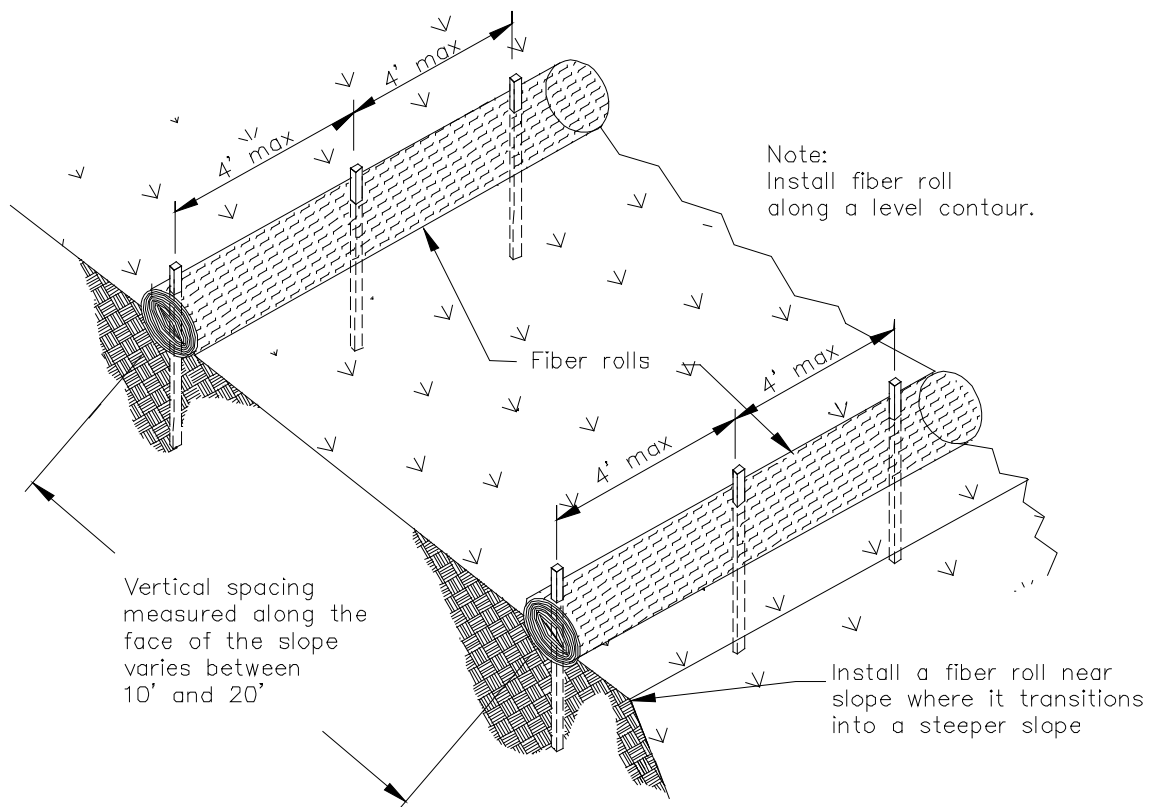

TYPICAL FIBER ROLL INSTALLATION

N.T.S.

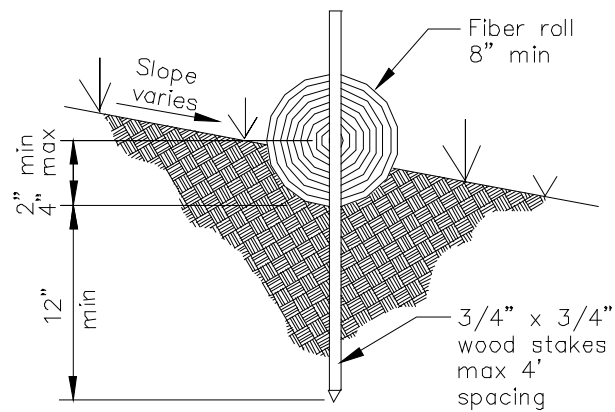

ENTRENCHMENT DETAIL

N.T.S.

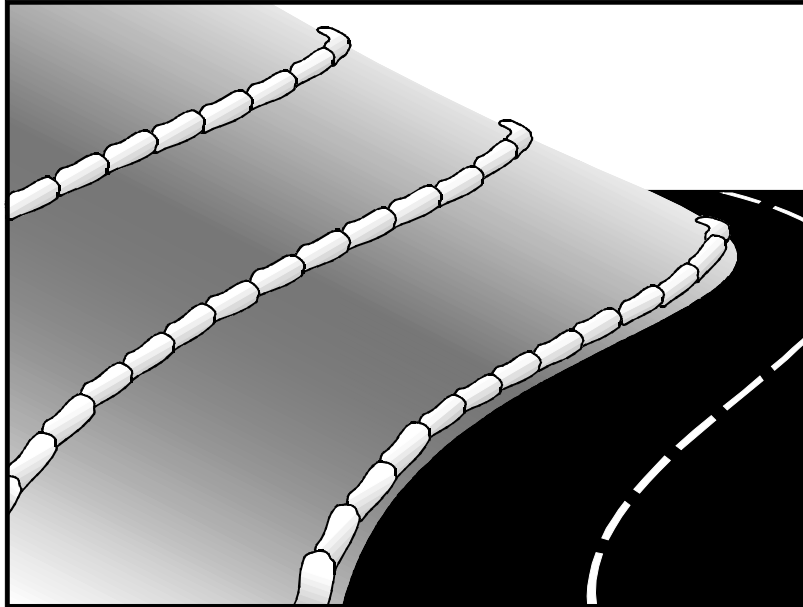

Description and Purpose

A gravel bag berm is a series of gravel-filled bags placed on a level contour to intercept sheet flows. Gravel bags pond sheet flow runoff, allowing sediment to settle out, and release runoff slowly as sheet flow, preventing erosion.

Suitable Applications

Gravel bag berms may be suitable:

- As a linear sediment control measure:
 - Below the toe of slopes and erodible slopes
 - As sediment traps at culvert/pipe outlets
 - Below other small cleared areas
 - Along the perimeter of a site
 - Down slope of exposed soil areas
 - Around temporary stockpiles and spoil areas
 - Parallel to a roadway to keep sediment off paved areas
 - Along streams and channels
- As a linear erosion control measure:
 - Along the face and at grade breaks of exposed and erodible slopes to shorten slope length and spread runoff as sheet flow.

Categories

EC	Erosion Control	<input checked="" type="checkbox"/>
SE	Sediment Control	<input checked="" type="checkbox"/>
TC	Tracking Control	
WE	Wind Erosion Control	
NS	Non-Stormwater Management Control	
WM	Waste Management and Materials Pollution Control	

Legend:

- Primary Category
- Secondary Category

Targeted Constituents

Sediment	<input checked="" type="checkbox"/>
Nutrients	
Trash	
Metals	
Bacteria	
Oil and Grease	
Organics	

Potential Alternatives

- SE-1 Silt Fence
- SE-5 Fiber Roll
- SE-8 Sandbag Barrier
- SE-12 Temporary Silt Dike
- SE-14 Biofilter Bags

If User/Subscriber modifies this fact sheet in any way, the CASQA name/logo and footer below must be removed from each page and not appear on the modified version.



- At the top of slopes to divert runoff away from disturbed slopes.
- As chevrons (small check dams) across mildly sloped construction roads. For use check dam use in channels, see SE-4, Check Dams.

Limitations

- Gravel berms may be difficult to remove.
- Removal problems limit their usefulness in landscaped areas.
- Gravel bag berm may not be appropriate for drainage areas greater than 5 acres.
- Runoff will pond upstream of the berm, possibly causing flooding if sufficient space does not exist.
- Degraded gravel bags may rupture when removed, spilling contents.
- Installation can be labor intensive.
- Durability of gravel bags is somewhat limited and bags may need to be replaced when installation is required for longer than 6 months.
- Easily damaged by construction equipment.
- When used to detain concentrated flows, maintenance requirements increase.

Implementation

General

A gravel bag berm consists of a row of open graded gravel-filled bags placed on a level contour. When appropriately placed, a gravel bag berm intercepts and slows sheet flow runoff, causing temporary ponding. The temporary ponding allows sediment to settle. The open graded gravel in the bags is porous, which allows the ponded runoff to flow slowly through the bags, releasing the runoff as sheet flows. Gravel bag berms also interrupt the slope length and thereby reduce erosion by reducing the tendency of sheet flows to concentrate into rivulets, which erode rills, and ultimately gullies, into disturbed, sloped soils. Gravel bag berms are similar to sand bag barriers, but are more porous. Generally, gravel bag berms should be used in conjunction with temporary soil stabilization controls up slope to provide effective erosion and sediment control.

Design and Layout

- Locate gravel bag berms on level contours.
- When used for slope interruption, the following slope/sheet flow length combinations apply:
 - Slope inclination of 4:1 (H:V) or flatter: Gravel bags should be placed at a maximum interval of 20 ft, with the first row near the slope toe.
 - Slope inclination between 4:1 and 2:1 (H:V): Gravel bags should be placed at a maximum interval of 15 ft. (a closer spacing is more effective), with the first row near the slope toe.

Slope inclination 2:1 (H:V) or greater: Gravel bags should be placed at a maximum interval of 10 ft. (a closer spacing is more effective), with the first row near the slope toe.

- Turn the ends of the gravel bag barriers up slope to prevent runoff from going around the berm.
- Allow sufficient space up slope from the gravel bag berm to allow ponding, and to provide room for sediment storage.
- For installation near the toe of the slope, gravel bag barriers should be set back from the slope toe to facilitate cleaning. Where specific site conditions do not allow for a set-back, the gravel bag barrier may be constructed on the toe of the slope. To prevent flows behind the barrier, bags can be placed perpendicular to a berm to serve as cross barriers.
- Drainage area should not exceed 5 acres.
- In Non-Traffic Areas:
 - Height = 18 in. maximum
 - Top width = 24 in. minimum for three or more layer construction
 - Top width = 12 in. minimum for one or two layer construction
 - Side slopes = 2:1 (H:V) or flatter
- In Construction Traffic Areas:
 - Height = 12 in. maximum
 - Top width = 24 in. minimum for three or more layer construction.
 - Top width = 12 in. minimum for one or two layer construction.
 - Side slopes = 2:1 (H:V) or flatter.
- Butt ends of bags tightly.
- On multiple row, or multiple layer construction, overlap butt joints of adjacent row and row beneath.
- Use a pyramid approach when stacking bags.

Materials

- **Bag Material:** Bags should be woven polypropylene, polyethylene or polyamide fabric or burlap, minimum unit weight of 4 ounces/yd², Mullen burst strength exceeding 300 lb/in² in conformance with the requirements in ASTM designation D3786, and ultraviolet stability exceeding 70% in conformance with the requirements in ASTM designation D4355.

- **Bag Size:** Each gravel-filled bag should have a length of 18 in., width of 12 in., thickness of 3 in., and mass of approximately 33 lbs. Bag dimensions are nominal, and may vary based on locally available materials.
- **Fill Material:** Fill material should be 0.5 to 1 in. crushed rock, clean and free from clay, organic matter, and other deleterious material, or other suitable open graded, non-cohesive, porous gravel.

Costs

Material costs for gravel bags are average and are dependent upon material availability. \$2.50-3.00 per filled gravel bag is standard based upon vendor research.

Inspection and Maintenance

- BMPs must be inspected in accordance with General Permit requirements for the associated project type and risk level. It is recommended that at a minimum, BMPs be inspected weekly, prior to forecasted rain events, daily during extended rain events, and after the conclusion of rain events.
- Gravel bags exposed to sunlight will need to be replaced every two to three months due to degrading of the bags.
- Reshape or replace gravel bags as needed.
- Repair washouts or other damage as needed.
- Sediment that accumulates in the BMP should be periodically removed in order to maintain BMP effectiveness. Sediment should be removed when the sediment accumulation reaches one-third of the barrier height.
- Remove gravel bag berms when no longer needed and recycle gravel fill whenever possible and properly dispose of bag material. Remove sediment accumulation and clean, re-grade, and stabilize the area.

References

Handbook of Steel Drainage and Highway Construction, American Iron and Steel Institute, 1983.

Stormwater Quality Handbooks - Construction Site Best Management Practices (BMPs) Manual, State of California Department of Transportation (Caltrans), March 2003.

Stormwater Pollution Plan Handbook, First Edition, State of California, Department of Transportation Division of New Technology, Materials and Research, October 1992.

Erosion and Sediment Control Manual, Oregon Department of Environmental Quality, February 2005.



Description and Purpose

Street sweeping and vacuuming includes use of self-propelled and walk-behind equipment to remove sediment from streets and roadways, and to clean paved surfaces in preparation for final paving. Sweeping and vacuuming prevents sediment from the project site from entering storm drains or receiving waters.

Suitable Applications

Sweeping and vacuuming are suitable anywhere sediment is tracked from the project site onto public or private paved streets and roads, typically at points of egress. Sweeping and vacuuming are also applicable during preparation of paved surfaces for final paving.

Limitations

Sweeping and vacuuming may not be effective when sediment is wet or when tracked soil is caked (caked soil may need to be scraped loose).

Implementation

- Controlling the number of points where vehicles can leave the site will allow sweeping and vacuuming efforts to be focused, and perhaps save money.
- Inspect potential sediment tracking locations daily.
- Visible sediment tracking should be swept or vacuumed on a daily basis.

Categories

EC	Erosion Control	
SE	Sediment Control	<input checked="" type="checkbox"/>
TC	Tracking Control	<input checked="" type="checkbox"/>
WE	Wind Erosion Control	
NS	Non-Stormwater Management Control	
WM	Waste Management and Materials Pollution Control	

Legend:

- Primary Objective
- Secondary Objective

Targeted Constituents

Sediment	<input checked="" type="checkbox"/>
Nutrients	
Trash	<input checked="" type="checkbox"/>
Metals	
Bacteria	
Oil and Grease	<input checked="" type="checkbox"/>
Organics	

Potential Alternatives

None

If User/Subscriber modifies this fact sheet in any way, the CASQA name/logo and footer below must be removed from each page and not appear on the modified version.



- Do not use kick brooms or sweeper attachments. These tend to spread the dirt rather than remove it.
- If not mixed with debris or trash, consider incorporating the removed sediment back into the project

Costs

Rental rates for self-propelled sweepers vary depending on hopper size and duration of rental. Expect rental rates from \$58/hour (3 yd³ hopper) to \$88/hour (9 yd³ hopper), plus operator costs. Hourly production rates vary with the amount of area to be swept and amount of sediment. Match the hopper size to the area and expect sediment load to minimize time spent dumping.

Inspection and Maintenance

- Inspect BMPs in accordance with General Permit requirements for the associated project type and risk level. It is recommended that at a minimum, BMPs be inspected weekly, prior to forecasted rain events, daily during extended rain events, and after the conclusion of rain events.
- When actively in use, points of ingress and egress must be inspected daily.
- When tracked or spilled sediment is observed outside the construction limits, it must be removed at least daily. More frequent removal, even continuous removal, may be required in some jurisdictions.
- Be careful not to sweep up any unknown substance or any object that may be potentially hazardous.
- Adjust brooms frequently; maximize efficiency of sweeping operations.
- After sweeping is finished, properly dispose of sweeper wastes at an approved dumpsite.

References

Stormwater Quality Handbooks - Construction Site Best Management Practices (BMPs) Manual, State of California Department of Transportation (Caltrans), November 2000.

Labor Surcharge and Equipment Rental Rates, State of California Department of Transportation (Caltrans), April 1, 2002 – March 31, 2003.

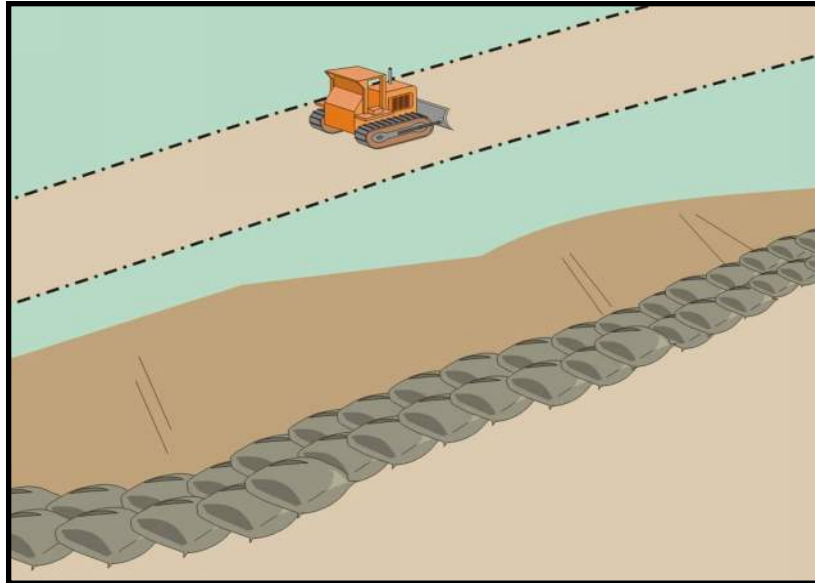

Description and Purpose

A sandbag barrier is a series of sand-filled bags placed on a level contour to intercept or to divert sheet flows. Sandbag barriers placed on a level contour pond sheet flow runoff, allowing sediment to settle out.

Suitable Applications

Sandbag barriers may be a suitable control measure for the applications described below. It is important to consider that sand bags are less porous than gravel bags and ponding or flooding can occur behind the barrier. Also, sand is easily transported by runoff if bags are damaged or ruptured. The SWPPP Preparer should select the location of a sandbag barrier with respect to the potential for flooding, damage, and the ability to maintain the BMP.

- As a linear sediment control measure:
 - Below the toe of slopes and erodible slopes.
 - As sediment traps at culvert/pipe outlets.
 - Below other small cleared areas.
 - Along the perimeter of a site.
 - Down slope of exposed soil areas.
 - Around temporary stockpiles and spoil areas.
 - Parallel to a roadway to keep sediment off paved areas.
 - Along streams and channels.

Categories

EC	Erosion Control	<input checked="" type="checkbox"/>
SE	Sediment Control	<input checked="" type="checkbox"/>
TC	Tracking Control	
WE	Wind Erosion Control	
NS	Non-Stormwater Management Control	
WM	Waste Management and Materials Pollution Control	

Legend:

- Primary Category**
- Secondary Category**

Targeted Constituents

Sediment	<input checked="" type="checkbox"/>
Nutrients	
Trash	
Metals	
Bacteria	
Oil and Grease	
Organics	

Potential Alternatives

- SE-1 Silt Fence
- SE-5 Fiber Rolls
- SE-6 Gravel Bag Berm
- SE-12 Manufactured Linear Sediment Controls
- SE-14 Biofilter Bags

If User/Subscriber modifies this fact sheet in any way, the CASQA name/logo and footer below must be removed from each page and not appear on the modified version.



- As linear erosion control measure:
 - Along the face and at grade breaks of exposed and erodible slopes to shorten slope length and spread runoff as sheet flow.
 - At the top of slopes to divert runoff away from disturbed slopes.
 - As check dams across mildly sloped construction roads.

Limitations

- It is necessary to limit the drainage area upstream of the barrier to 5 acres.
- Sandbags are not intended to be used as filtration devices.
- Easily damaged by construction equipment.
- Degraded sandbags may rupture when removed, spilling sand.
- Installation can be labor intensive.
- Durability of sandbags is somewhat limited and bags will need to be replaced when there are signs of damage or wear.
- Burlap should not be used for sandbags.

Implementation

General

A sandbag barrier consists of a row of sand-filled bags placed on a level contour. When appropriately placed, a sandbag barrier intercepts and slows sheet flow runoff, causing temporary ponding. The temporary ponding allows sediment to settle. Sand-filled bags have limited porosity, which is further limited as the fine sand tends to quickly plug with sediment, limiting or completely blocking the rate of flow through the barrier. If a porous barrier is desired, consider SE-1, Silt Fence, SE-5, Fiber Rolls, SE-6, Gravel Bag Berms or SE-14, Biofilter Bags. Sandbag barriers also interrupt the slope length and thereby reduce erosion by reducing the tendency of sheet flows to concentrate into rivulets which erode rills, and ultimately gullies, into disturbed, sloped soils. Sandbag barriers are similar to gravel bag berms, but less porous. Generally, sandbag barriers should be used in conjunction with temporary soil stabilization controls up slope to provide effective erosion and sediment control.

Design and Layout

- Locate sandbag barriers on a level contour.
- When used for slope interruption, the following slope/sheet flow length combinations apply:
 - Slope inclination of 4:1 (H:V) or flatter: Sandbags should be placed at a maximum interval of 20 ft, with the first row near the slope toe.
 - Slope inclination between 4:1 and 2:1 (H:V): Sandbags should be placed at a maximum interval of 15 ft. (a closer spacing is more effective), with the first row near the slope toe.

- Slope inclination 2:1 (H:V) or greater: Sandbags should be placed at a maximum interval of 10 ft. (a closer spacing is more effective), with the first row near the slope toe.
- Turn the ends of the sandbag barrier up slope to prevent runoff from going around the barrier.
- Allow sufficient space up slope from the barrier to allow ponding, and to provide room for sediment storage.
- For installation near the toe of the slope, sand bag barriers should be set back from the slope toe to facilitate cleaning. Where specific site conditions do not allow for a set-back, the sand bag barrier may be constructed on the toe of the slope. To prevent flows behind the barrier, bags can be placed perpendicular to a berm to serve as cross barriers.
- Drainage area should not exceed 5 acres.
- Butt ends of bags tightly.
- Overlap butt joints of row beneath with each successive row.
- Use a pyramid approach when stacking bags.
- In non-traffic areas
 - Height = 18 in. maximum
 - Top width = 24 in. minimum for three or more layer construction
 - Side slope = 2:1 (H:V) or flatter
- In construction traffic areas
 - Height = 12 in. maximum
 - Top width = 24 in. minimum for three or more layer construction.
 - Side slopes = 2:1 (H:V) or flatter.
- See typical sandbag barrier installation details at the end of this fact sheet.

Materials

- **Sandbag Material:** Sandbag should be woven polypropylene, polyethylene or polyamide fabric, minimum unit weight of 4 ounces/yd², Mullen burst strength exceeding 300 lb/in² in conformance with the requirements in ASTM designation D3786, and ultraviolet stability exceeding 70% in conformance with the requirements in ASTM designation D4355. Use of burlap is not an acceptable substitute, as sand can more easily mobilize out of burlap.
- **Sandbag Size:** Each sand-filled bag should have a length of 18 in., width of 12 in., thickness of 3 in., and mass of approximately 33 lbs. Bag dimensions are nominal, and may vary based on locally available materials.

- **Fill Material:** All sandbag fill material should be non-cohesive, Class 3 (Caltrans Standard Specification, Section 25) or similar permeable material free from clay and deleterious material, such as recycled concrete or asphalt.

Costs

Empty sandbags cost \$0.25 - \$0.75. Average cost of fill material is \$8 per yd³. Additional labor is required to fill the bags. Pre-filled sandbags are more expensive at \$1.50 - \$2.00 per bag. These costs are based upon vendor research.

Inspection and Maintenance

- BMPs must be inspected in accordance with General Permit requirements for the associated project type and risk level. It is recommended that at a minimum, BMPs be inspected weekly, prior to forecasted rain events, daily during extended rain events, and after the conclusion of rain events.
- Sandbags exposed to sunlight will need to be replaced every two to three months due to degradation of the bags.
- Reshape or replace sandbags as needed.
- Repair washouts or other damage as needed.
- Sediment that accumulates behind the BMP should be periodically removed in order to maintain BMP effectiveness. Sediment should be removed when the sediment accumulation reaches one-third of the barrier height.
- Remove sandbags when no longer needed and recycle sand fill whenever possible and properly dispose of bag material. Remove sediment accumulation, and clean, re-grade, and stabilize the area.

References

Standard Specifications for Construction of Local Streets and Roads, California Department of Transportation (Caltrans), July 2002.

Stormwater Quality Handbooks - Construction Site Best Management Practices (BMPs) Manual, State of California Department of Transportation (Caltrans), March 2003.

Erosion and Sediment Control Manual, Oregon Department of Environmental Quality, February 2005.

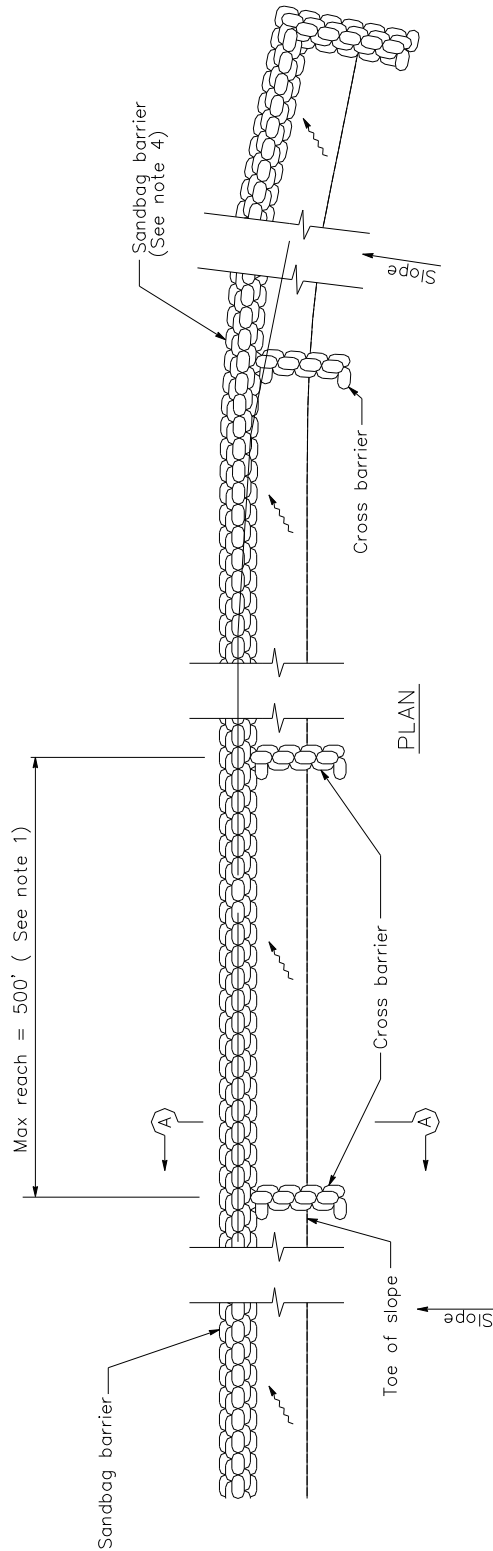

SANDBAG BARRIER

NOTES

1. Construct the length of each reach so that the change in base elevation along the reach does not exceed $1/2$ the height of the linear barrier. In no case shall the reach length exceed 500'.
2. Place sandbags tightly.
3. Dimension may vary to fit field condition.
4. Sandbag barrier shall be a minimum of 3 bags high.
5. The end of the barrier shall be turned up slope.
6. Cross barriers shall be a min of $1/2$ and a max of $2/3$ the height of the linear barrier.
7. Sandbag rows and layers shall be staggered to eliminate gaps.

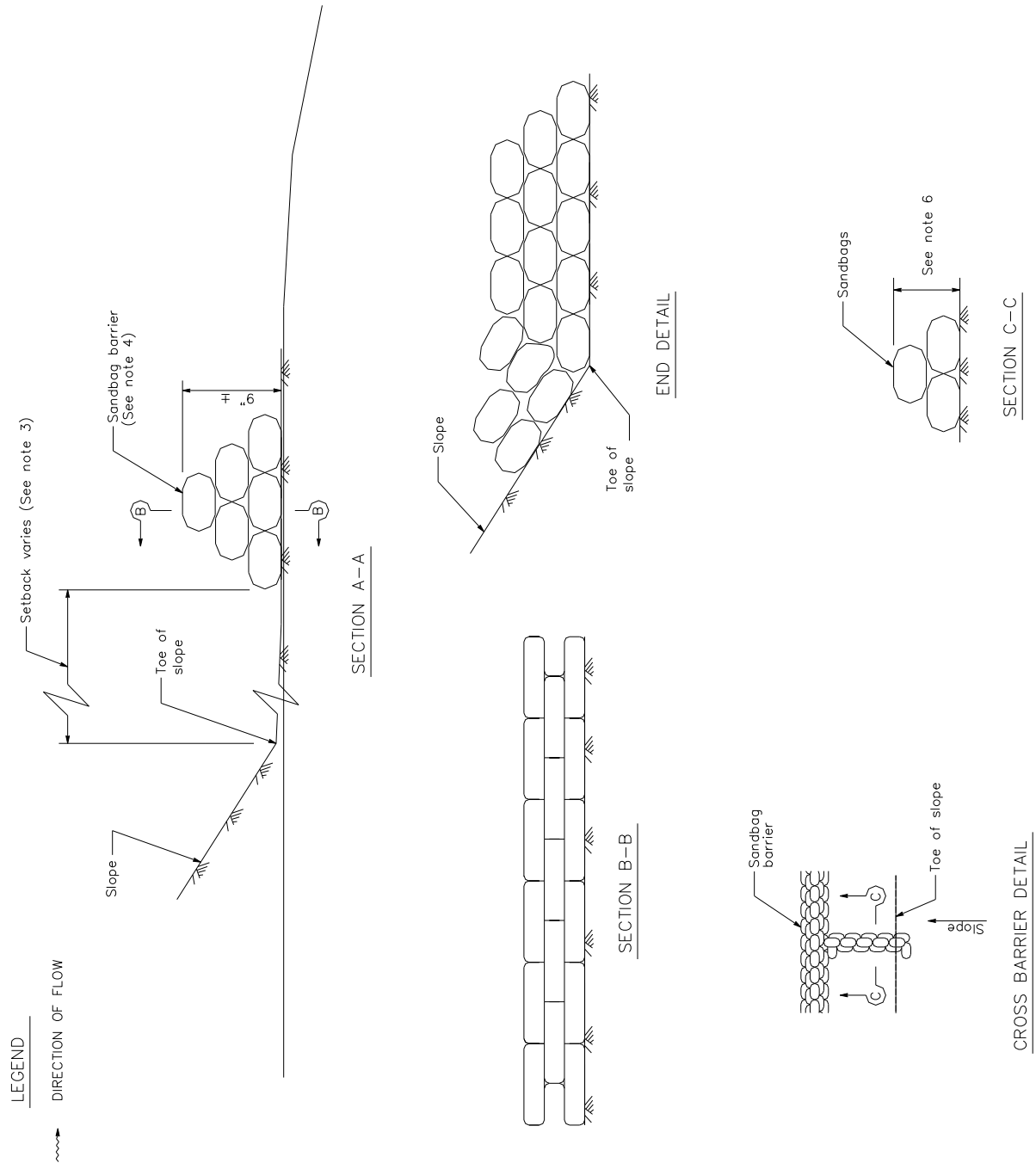

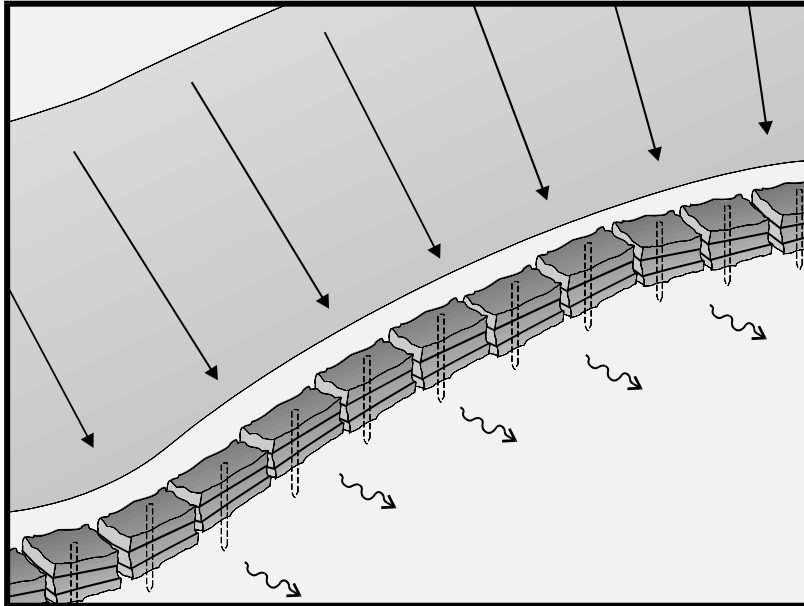

Description and Purpose

A straw bale barrier is a series of straw bales placed on a level contour to intercept sheet flows. Straw bale barriers pond sheet-flow runoff, allowing sediment to settle out.

Suitable Applications

Straw bale barriers may be suitable:

- As a linear sediment control measure:
 - Below the toe of slopes and erodible slopes
 - As sediment traps at culvert/pipe outlets
 - Below other small cleared areas
 - Along the perimeter of a site
 - Down slope of exposed soil areas
 - Around temporary stockpiles and spoil areas
 - Parallel to a roadway to keep sediment off paved areas
 - Along streams and channels
- As linear erosion control measure:
 - Along the face and at grade breaks of exposed and erodible slopes to shorten slope length and spread runoff as sheet flow

Categories

EC	Erosion Control	<input checked="" type="checkbox"/>
SE	Sediment Control	<input checked="" type="checkbox"/>
TC	Tracking Control	
WE	Wind Erosion Control	
NS	Non-Stormwater Management Control	
WM	Waste Management and Materials Pollution Control	

Legend:

- Primary Objective**
- Secondary Objective**

Targeted Constituents

Sediment	<input checked="" type="checkbox"/>
Nutrients	
Trash	
Metals	
Bacteria	
Oil and Grease	
Organics	

Potential Alternatives

- SE-1 Silt Fence
- SE-5 Fiber Rolls
- SE-6 Gravel Bag Berm
- SE-8 Sandbag Barrier
- SE-12 Temporary Silt Dike
- SE-14 Biofilter Bags

If User/Subscriber modifies this fact sheet in any way, the CASQA name/logo and footer below must be removed from each page and not appear on the modified version.



- At the top of slopes to divert runoff away from disturbed slopes
- As check dams across mildly sloped construction roads

Limitations

Straw bale barriers:

- Are not to be used for extended periods of time because they tend to rot and fall apart
- Are suitable only for sheet flow on slopes of 10 % or flatter
- Are not appropriate for large drainage areas, limit to one acre or less
- May require constant maintenance due to rotting
- Are not recommended for concentrated flow, inlet protection, channel flow, and live streams
- Cannot be made of bale bindings of jute or cotton
- Require labor-intensive installation and maintenance
- Cannot be used on paved surfaces
- Should not to be used for drain inlet protection
- Should not be used on lined ditches
- May introduce undesirable non-native plants to the area

Implementation

General

A straw bale barrier consists of a row of straw bales placed on a level contour. When appropriately placed, a straw bale barrier intercepts and slows sheet flow runoff, causing temporary ponding. The temporary ponding provides quiescent conditions allowing sediment to settle. Straw bale barriers also interrupt the slope length and thereby reduce erosion by reducing the tendency of sheet flows to concentrate into rivulets, which erode rills, and ultimately gullies, into disturbed, sloped soils.

Straw bale barriers have not been as effective as expected due to improper use. These barriers have been placed in streams and drainage ways where runoff volumes and velocities have caused the barriers to wash out. In addition, failure to stake and entrench the straw bale has allowed undercutting and end flow. Use of straw bale barriers in accordance with this BMP should produce acceptable results.

Design and Layout

- Locate straw bale barriers on a level contour.
 - Slopes up to 10:1 (H:V): Straw bales should be placed at a maximum interval of 50 ft (a closer spacing is more effective), with the first row near the toe of slope.
 - Slopes greater than 10:1 (H:V): Not recommended.

- Turn the ends of the straw bale barrier up slope to prevent runoff from going around the barrier.
- Allow sufficient space up slope from the barrier to allow ponding, and to provide room for sediment storage.
- For installation near the toe of the slope, consider moving the barrier away from the slope toe to facilitate cleaning. To prevent flow behind the barrier, sand bags can be placed perpendicular to the barrier to serve as cross barriers.
- Drainage area should not exceed 1 acre, or 0.25 acre per 100 ft of barrier.
- Maximum flow path to the barrier should be limited to 100 ft.
- Straw bale barriers should consist of two parallel rows.
 - Butt ends of bales tightly
 - Stagger butt joints between front and back row
 - Each row of bales must be trenched in and firmly staked
- Straw bale barriers are limited in height to one bale laid on its side.
- Anchor bales with either two wood stakes or four bars driven through the bale and into the soil. Drive the first stake towards the butt joint with the adjacent bale to force the bales together.
- See attached figure for installation details.

Materials

- **Straw Bale Size:** Each straw bale should be a minimum of 14 in. wide, 18 in. in height, 36 in. in length and should have a minimum mass of 50 lbs. The straw bale should be composed entirely of vegetative matter, except for the binding material.
- **Bale Bindings:** Bales should be bound by steel wire, nylon or polypropylene string placed horizontally. Jute and cotton binding should not be used. Baling wire should be a minimum diameter of 14 gauge. Nylon or polypropylene string should be approximately 12 gauge in diameter with a breaking strength of 80 lbs force.
- **Stakes:** Wood stakes should be commercial quality lumber of the size and shape shown on the plans. Each stake should be free from decay, splits or cracks longer than the thickness of the stake, or other defects that would weaken the stakes and cause the stakes to be structurally unsuitable. Steel bar reinforcement should be equal to a #4 designation or greater. End protection should be provided for any exposed bar reinforcement.

Costs

Straw bales cost \$5 - \$7 each. Adequate labor should be budgeted for installation and maintenance.

Inspection and Maintenance

Maintenance

- Inspect BMPs in accordance with General Permit requirements for the associated project type and risk level. It is recommended that at a minimum, BMPs be inspected weekly, prior to forecasted rain events, daily during extended rain events, and after the conclusion of rain events.
- Straw bales degrade, especially when exposed to moisture. Rotting bales will need to be replaced on a regular basis.
- Replace or repair damaged bales as needed.
- Repair washouts or other damages as needed.
- Sediment that accumulates in the BMP must be periodically removed in order to maintain BMP effectiveness. Sediment should be removed when the sediment accumulation reaches one-third of the barrier height. Sediment removed during maintenance may be incorporated into earthwork on the site or disposed at an appropriate location.
- Remove straw bales when no longer needed. Remove sediment accumulation, and clean, re-grade, and stabilize the area. Removed sediment should be incorporated in the project or disposed of.

References

Stormwater Quality Handbooks - Construction Site Best Management Practices (BMPs) Manual, State of California Department of Transportation (Caltrans), November 2000.

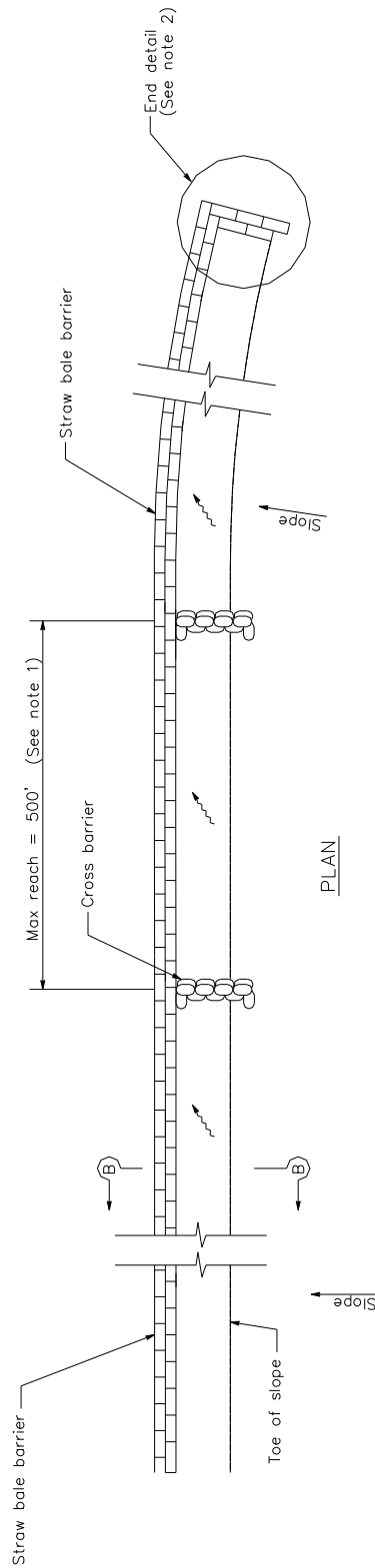

NOTES

1. Construct the length of each reach so that the change in base elevation along the reach does not exceed $1/2$ the height of the linear barrier. In no case shall the reach length exceed 500'.
2. The end of barrier shall be turned up slope.
3. Dimension may vary to fit field condition.
4. Stake dimensions are nominal.
5. Place straw bales tightly together.
6. Tamp embedment spoils against sides of installed bales.
7. Drive angled wood stake before vertical stake to ensure tight abutment to adjacent bale.
8. Sandbag cross barriers should be a min of $1/2$ and a max of $2/3$ the height of the linear barrier.
9. Sandbag rows and layers should be offset to eliminate gaps.

LEGEND

—————> DIRECTION OF FLOW



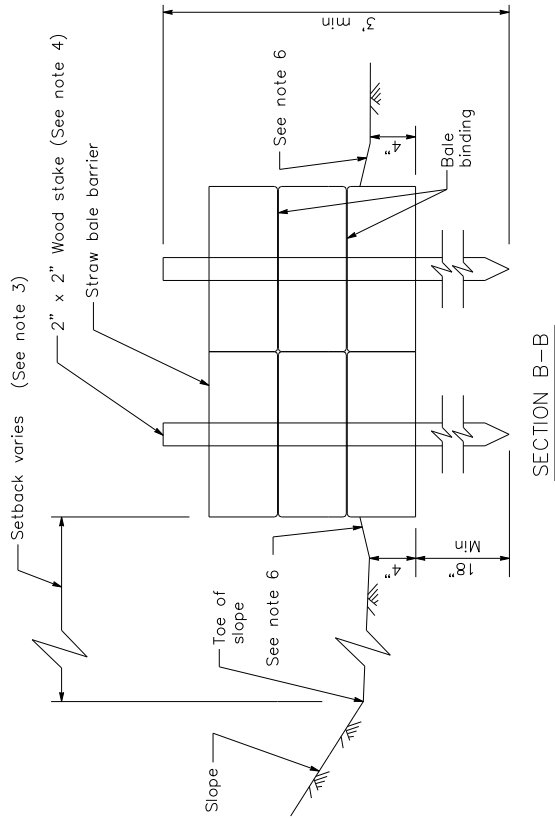

SECTION B-B

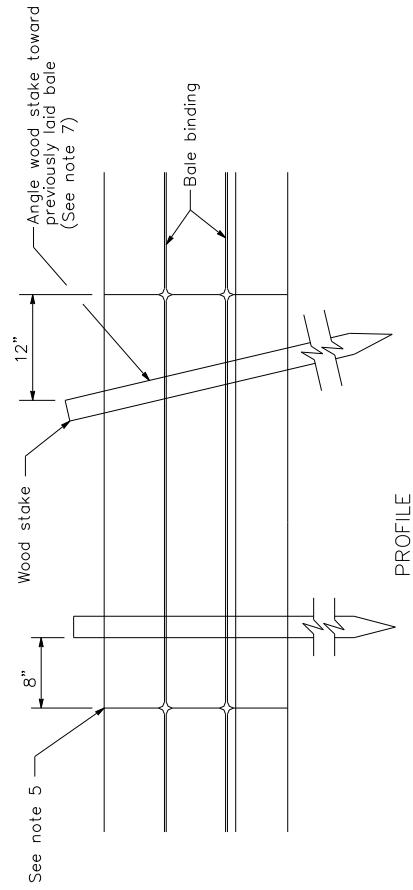

PROFILE

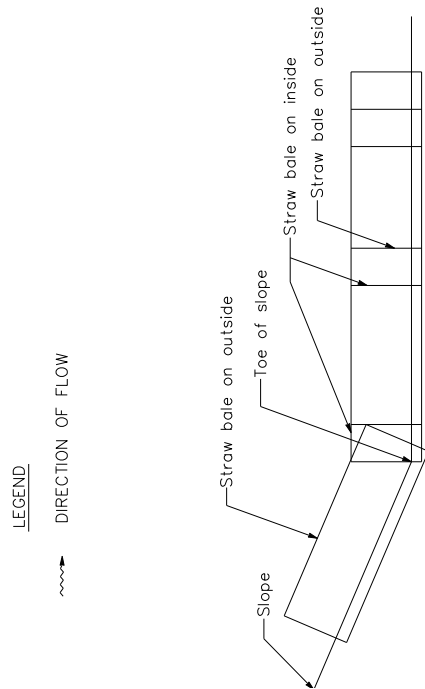

END DETAIL

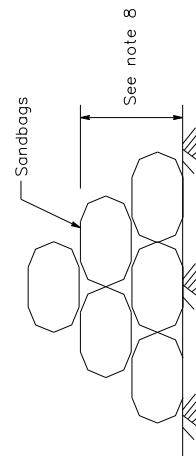

SANDBAG CROSS BARRIER

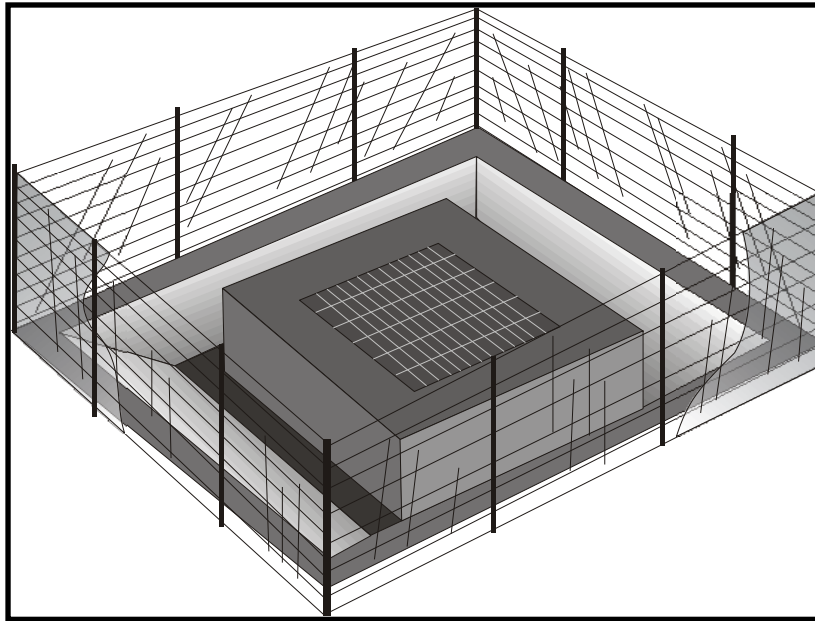

Description and Purpose

Storm drain inlet protection consists of a sediment filter or an impounding area in, around or upstream of a storm drain, drop inlet, or curb inlet. Storm drain inlet protection measures temporarily pond runoff before it enters the storm drain, allowing sediment to settle. Some filter configurations also remove sediment by filtering, but usually the ponding action results in the greatest sediment reduction. Temporary geotextile storm drain inserts attach underneath storm drain grates to capture and filter storm water.

Suitable Applications

- Every storm drain inlet receiving runoff from unstabilized or otherwise active work areas should be protected. Inlet protection should be used in conjunction with other erosion and sediment controls to prevent sediment-laden stormwater and non-stormwater discharges from entering the storm drain system.

Limitations

- Drainage area should not exceed 1 acre.
- In general straw bales should not be used as inlet protection.
- Requires an adequate area for water to pond without encroaching into portions of the roadway subject to traffic.
- Sediment removal may be inadequate to prevent sediment discharges in high flow conditions or if runoff is heavily sediment laden. If high flow conditions are expected, use

Categories

EC	Erosion Control	
SE	Sediment Control	<input checked="" type="checkbox"/>
TC	Tracking Control	
WE	Wind Erosion Control	
NS	Non-Stormwater Management Control	
WM	Waste Management and Materials Pollution Control	

Legend:

- Primary Category**
- Secondary Category**

Targeted Constituents

Sediment	<input checked="" type="checkbox"/>
Nutrients	
Trash	<input checked="" type="checkbox"/>
Metals	
Bacteria	
Oil and Grease	
Organics	

Potential Alternatives

- SE-1 Silt Fence
- SE-5 Fiber Rolls
- SE-6 Gravel Bag Berm
- SE-8 Sandbag Barrier
- SE-14 Biofilter Bags
- SE-13 Compost Socks and Berms

If User/Subscriber modifies this fact sheet in any way, the CASQA name/logo and footer below must be removed from each page and not appear on the modified version.



other onsite sediment trapping techniques in conjunction with inlet protection.

- Frequent maintenance is required.
- Limit drainage area to 1 acre maximum. For drainage areas larger than 1 acre, runoff should be routed to a sediment-trapping device designed for larger flows. See BMPs SE-2, Sediment Basin, and SE-3, Sediment Traps.
- Excavated drop inlet sediment traps are appropriate where relatively heavy flows are expected, and overflow capability is needed.

Implementation

General

Inlet control measures presented in this handbook should not be used for inlets draining more than one acre. Runoff from larger disturbed areas should be first routed through SE-2, Sediment Basin or SE-3, Sediment Trap and/or used in conjunction with other drainage control, erosion control, and sediment control BMPs to protect the site. Different types of inlet protection are appropriate for different applications depending on site conditions and the type of inlet. Alternative methods are available in addition to the methods described/shown herein such as prefabricated inlet insert devices, or gutter protection devices.

Design and Layout

Identify existing and planned storm drain inlets that have the potential to receive sediment-laden surface runoff. Determine if storm drain inlet protection is needed and which method to use.

- The key to successful and safe use of storm drain inlet protection devices is to know where runoff that is directed toward the inlet to be protected will pond or be diverted as a result of installing the protection device.
 - Determine the acceptable location and extent of ponding in the vicinity of the drain inlet. The acceptable location and extent of ponding will influence the type and design of the storm drain inlet protection device.
 - Determine the extent of potential runoff diversion caused by the storm drain inlet protection device. Runoff ponded by inlet protection devices may flow around the device and towards the next downstream inlet. In some cases, this is acceptable; in other cases, serious erosion or downstream property damage can be caused by these diversions. The possibility of runoff diversions will influence whether or not storm drain inlet protection is suitable; and, if suitable, the type and design of the device.
- The location and extent of ponding, and the extent of diversion, can usually be controlled through appropriate placement of the inlet protection device. In some cases, moving the inlet protection device a short distance upstream of the actual inlet can provide more efficient sediment control, limit ponding to desired areas, and prevent or control diversions.
- Seven types of inlet protection are presented below. However, it is recognized that other effective methods and proprietary devices exist and may be selected.

- Silt Fence: Appropriate for drainage basins with less than a 5% slope, sheet flows, and flows under 0.5 cfs.
 - Excavated Drop Inlet Sediment Trap: An excavated area around the inlet to trap sediment (SE-3).
 - Gravel bag barrier: Used to create a small sediment trap upstream of inlets on sloped, paved streets. Appropriate for sheet flow or when concentrated flow may exceed 0.5 cfs, and where overtopping is required to prevent flooding.
 - Block and Gravel Filter: Appropriate for flows greater than 0.5 cfs.
 - Temporary Geotextile Storm drain Inserts: Different products provide different features. Refer to manufacturer details for targeted pollutants and additional features.
 - Biofilter Bag Barrier: Used to create a small retention area upstream of inlets and can be located on pavement or soil. Biofilter bags slowly filter runoff allowing sediment to settle out. Appropriate for flows under 0.5 cfs.
 - Compost Socks: Allow filtered run-off to pass through the compost while retaining sediment and potentially other pollutants (SE-13). Appropriate for flows under 1.0 cfs.
- Select the appropriate type of inlet protection and design as referred to or as described in this fact sheet.
 - Provide area around the inlet for water to pond without flooding structures and property.
 - Grates and spaces around all inlets should be sealed to prevent seepage of sediment-laden water.
 - Excavate sediment sumps (where needed) 1 to 2 ft with 2:1 side slopes around the inlet.

Installation

- **DI Protection Type 1 - Silt Fence** - Similar to constructing a silt fence; see BMP SE-1, Silt Fence. Do not place fabric underneath the inlet grate since the collected sediment may fall into the drain inlet when the fabric is removed or replaced and water flow through the grate will be blocked resulting in flooding. See typical Type 1 installation details at the end of this fact sheet.
 1. Excavate a trench approximately 6 in. wide and 6 in. deep along the line of the silt fence inlet protection device.
 2. Place 2 in. by 2 in. wooden stakes around the perimeter of the inlet a maximum of 3 ft apart and drive them at least 18 in. into the ground or 12 in. below the bottom of the trench. The stakes should be at least 48 in.
 3. Lay fabric along bottom of trench, up side of trench, and then up stakes. See SE-1, Silt Fence, for details. The maximum silt fence height around the inlet is 24 in.
 4. Staple the filter fabric (for materials and specifications, see SE-1, Silt Fence) to wooden stakes. Use heavy-duty wire staples at least 1 in. in length.

5. Backfill the trench with gravel or compacted earth all the way around.
- **DI Protection Type 2 - Excavated Drop Inlet Sediment Trap** - Install filter fabric fence in accordance with DI Protection Type 1. Size excavated trap to provide a minimum storage capacity calculated at the rate 67 yd³/acre of drainage area. See typical Type 2 installation details at the end of this fact sheet.
 - **DI Protection Type 3 - Gravel bag** - Flow from a severe storm should not overtop the curb. In areas of high clay and silts, use filter fabric and gravel as additional filter media. Construct gravel bags in accordance with SE-6, Gravel Bag Berm. Gravel bags should be used due to their high permeability. See typical Type 3 installation details at the end of this fact sheet.
 1. Construct on gently sloping street.
 2. Leave room upstream of barrier for water to pond and sediment to settle.
 3. Place several layers of gravel bags – overlapping the bags and packing them tightly together.
 4. Leave gap of one bag on the top row to serve as a spillway. Flow from a severe storm (e.g., 10 year storm) should not overtop the curb.
 - **DI Protection Type 4 – Block and Gravel Filter** - Block and gravel filters are suitable for curb inlets commonly used in residential, commercial, and industrial construction. See typical Type 4 installation details at the end of this fact sheet.
 1. Place hardware cloth or comparable wire mesh with 0.5 in. openings over the drop inlet so that the wire extends a minimum of 1 ft beyond each side of the inlet structure. If more than one strip is necessary, overlap the strips. Place woven geotextile over the wire mesh.
 2. Place concrete blocks lengthwise on their sides in a single row around the perimeter of the inlet, so that the open ends face outward, not upward. The ends of adjacent blocks should abut. The height of the barrier can be varied, depending on design needs, by stacking combinations of blocks that are 4 in., 8 in., and 12 in. wide. The row of blocks should be at least 12 in. but no greater than 24 in. high.
 3. Place wire mesh over the outside vertical face (open end) of the concrete blocks to prevent stone from being washed through the blocks. Use hardware cloth or comparable wire mesh with 0.5 in. opening.
 4. Pile washed stone against the wire mesh to the top of the blocks. Use 0.75 to 3 in.
 - **DI Protection Type 5 – Temporary Geotextile Insert (proprietary)** – Many types of temporary inserts are available. Most inserts fit underneath the grate of a drop inlet or inside of a curb inlet and are fastened to the outside of the grate or curb. These inserts are removable and many can be cleaned and reused. Installation of these inserts differs between manufacturers. Please refer to manufacturer instruction for installation of proprietary devices.

- **DI Protection Type 6 - Biofilter bags** – Biofilter bags may be used as a substitute for gravel bags in low-flow situations. Biofilter bags should conform to specifications detailed in SE-14, Biofilter bags.
 1. Construct in a gently sloping area.
 2. Biofilter bags should be placed around inlets to intercept runoff flows.
 3. All bag joints should overlap by 6 in.
 4. Leave room upstream for water to pond and for sediment to settle out.
 5. Stake bags to the ground as described in the following detail. Stakes may be omitted if bags are placed on a paved surface.
- **DI Protection Type 7 – Compost Socks** – A compost sock can be assembled on site by filling a mesh sock (e.g., with a pneumatic blower). Compost socks do not require special trenching compared to other sediment control methods (e.g., silt fence). Compost socks should conform to specification detailed in SE-13, Compost Socks and Berms.

Costs

- Average annual cost for installation and maintenance of DI Type 1-4 and 6 (one year useful life) is \$200 per inlet.
- Temporary geotextile inserts are proprietary and cost varies by region. These inserts can often be reused and may have greater than 1 year of use if maintained and kept undamaged. Average cost per insert ranges from \$50-75 plus installation, but costs can exceed \$100. This cost does not include maintenance.
- See SE-13 for Compost Sock cost information.

Inspection and Maintenance

- BMPs must be inspected in accordance with General Permit requirements for the associated project type and risk level. It is recommended that at a minimum, BMPs be inspected weekly, prior to forecasted rain events, daily during extended rain events, and after the conclusion of rain events.
- Silt Fences. If the fabric becomes clogged, torn, or degrades, it should be replaced. Make sure the stakes are securely driven in the ground and are in good shape (i.e., not bent, cracked, or splintered, and are reasonably perpendicular to the ground). Replace damaged stakes. At a minimum, remove the sediment behind the fabric fence when accumulation reaches one-third the height of the fence or barrier height.
- Gravel Filters. If the gravel becomes clogged with sediment, it should be carefully removed from the inlet and either cleaned or replaced. Since cleaning gravel at a construction site may be difficult, consider using the sediment-laden stone as fill material and put fresh stone around the inlet. Inspect bags for holes, gashes, and snags, and replace bags as needed. Check gravel bags for proper arrangement and displacement.

- Sediment that accumulates in the BMP should be periodically removed in order to maintain BMP effectiveness. Sediment should be removed when the sediment accumulation reaches one-third of the barrier height.
- Inspect and maintain temporary geotextile insert devices according to manufacturer's specifications.
- Remove storm drain inlet protection once the drainage area is stabilized.
 - Clean and regrade area around the inlet and clean the inside of the storm drain inlet, as it should be free of sediment and debris at the time of final inspection.

References

Stormwater Quality Handbooks - Construction Site Best Management Practices (BMPs) Manual, State of California Department of Transportation (Caltrans), March 2003.

Stormwater Management Manual for The Puget Sound Basin, Washington State Department of Ecology, Public Review Draft, 1991.

Erosion and Sediment Control Manual, Oregon Department of Environmental Quality, February 2005.

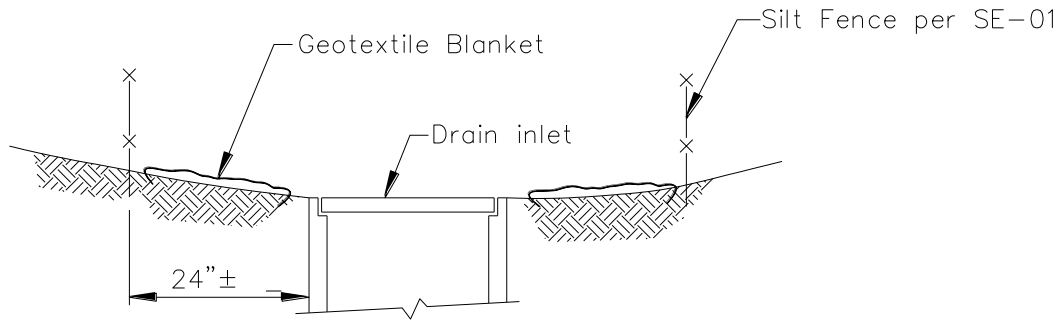

SECTION A-A

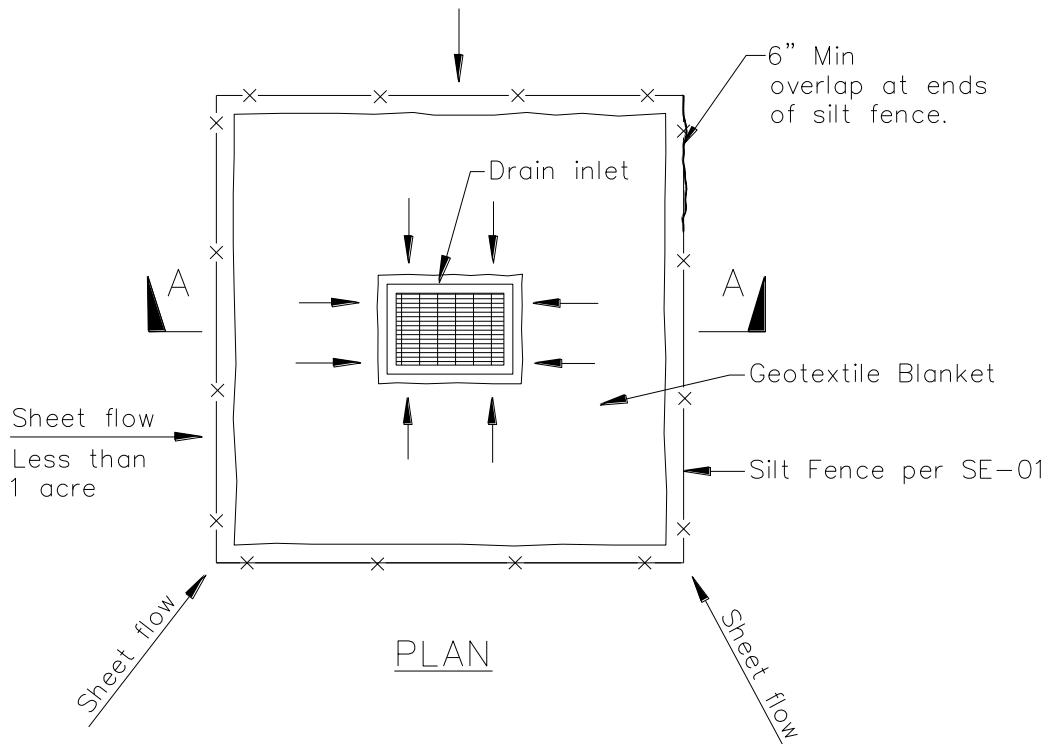

PLAN

DI PROTECTION TYPE 1
NOT TO SCALE

NOTES:

1. For use in areas where grading has been completed and final soil stabilization and seeding are pending.
2. Not applicable in paved areas.
3. Not applicable with concentrated flows.

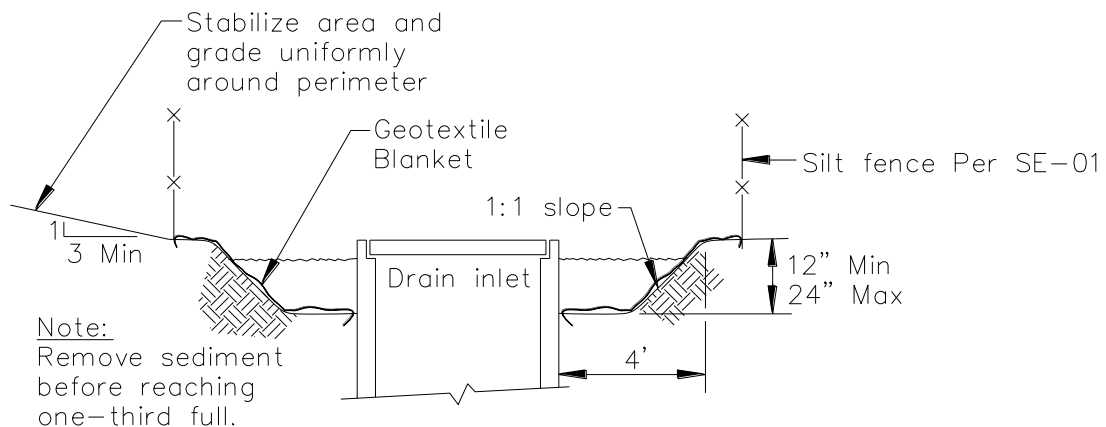

Section A-A

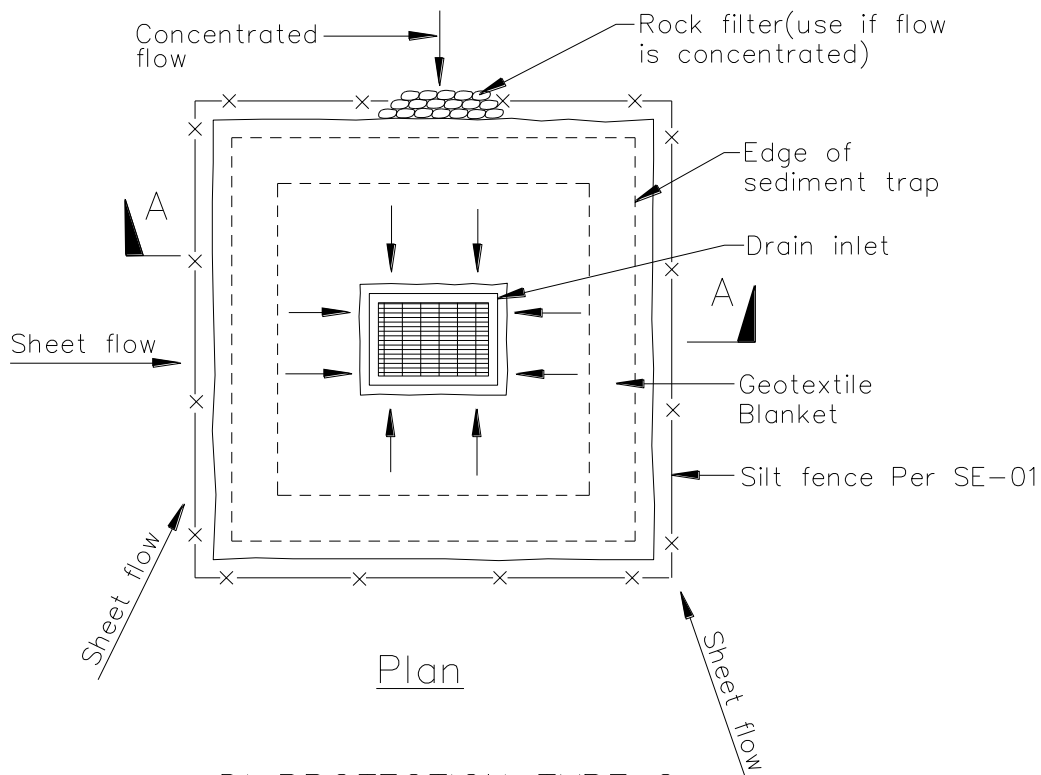

Plan

DI PROTECTION TYPE 2
NOT TO SCALE

Notes

1. For use in cleared and grubbed and in graded areas.
2. Shape basin so that longest inflow area faces longest length of trap.
3. For concentrated flows, shape basin in 2:1 ratio with length oriented towards direction of flow.

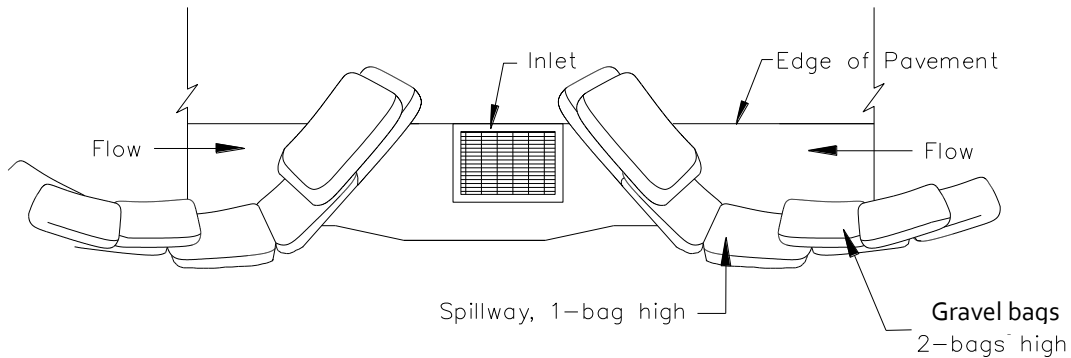

TYPICAL PROTECTION FOR INLET ON SUMP

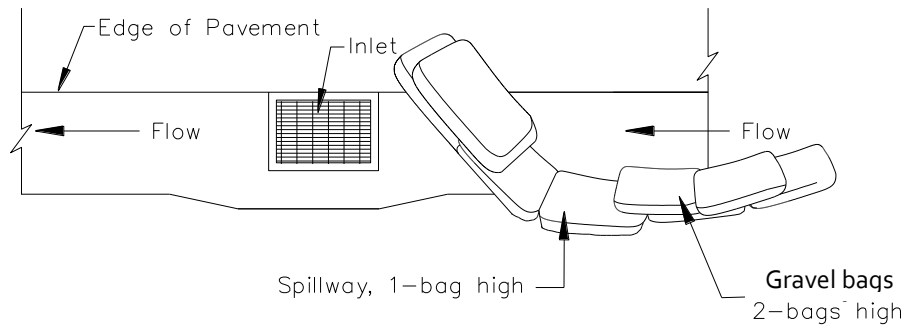

TYPICAL PROTECTION FOR INLET ON GRADE

NOTES:

1. Intended for short-term use.
2. Use to inhibit non-storm water flow.
3. Allow for proper maintenance and cleanup.
4. Bags must be removed after adjacent operation is completed
5. Not applicable in areas with high silts and clays without filter fabric.
6. Protection can be effective even if it is not immediately adjacent to the inlet provided that the inlet is protected from potential sources of pollution.

DI PROTECTION TYPE 3
NOT TO SCALE

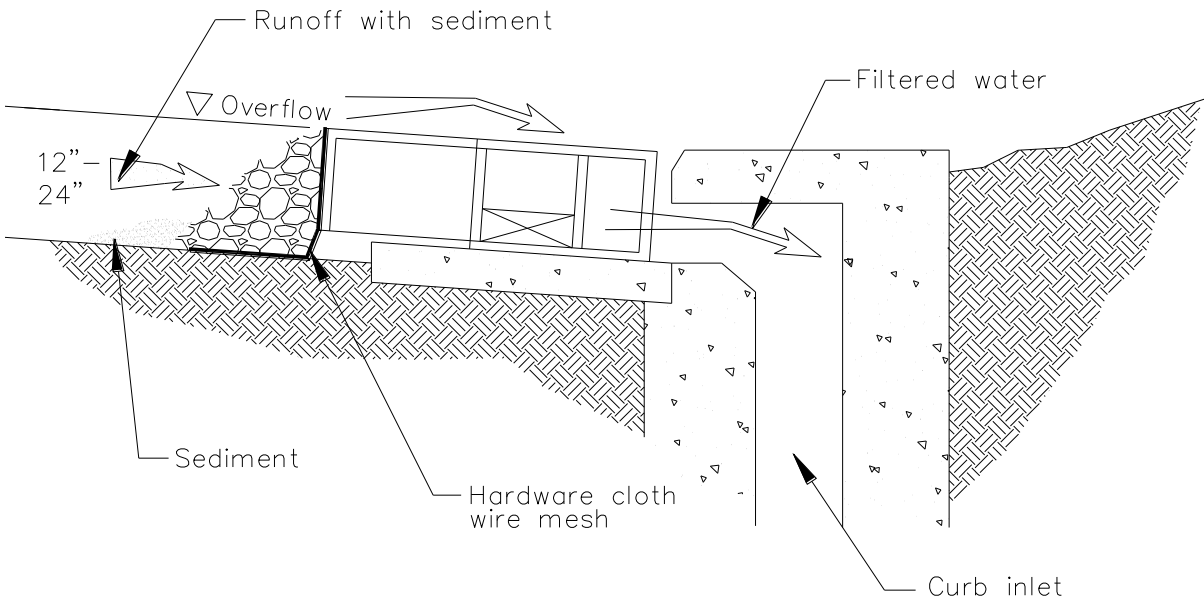
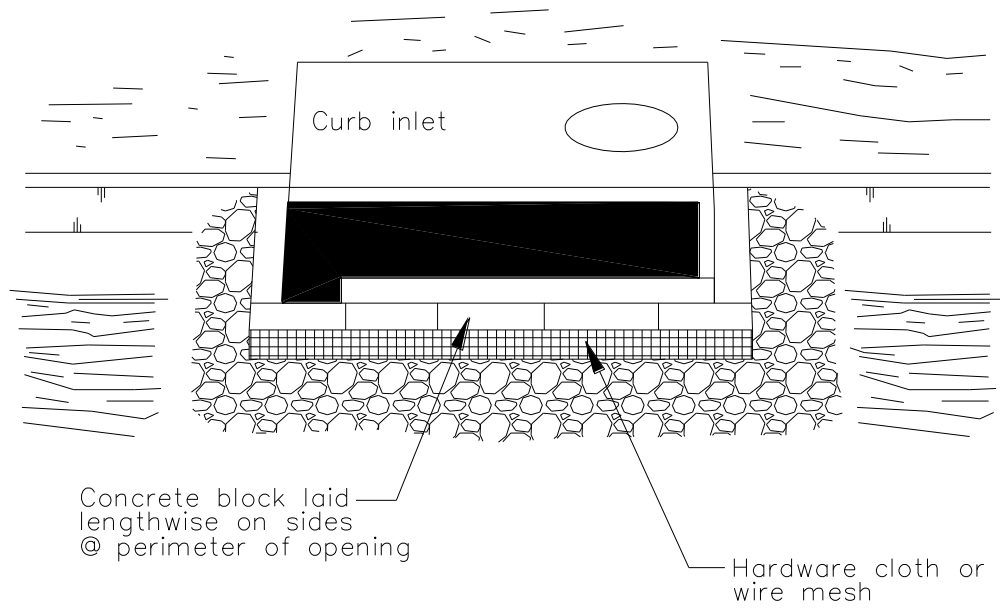

DI PROTECTION — TYPE 4
NOT TO SCALE

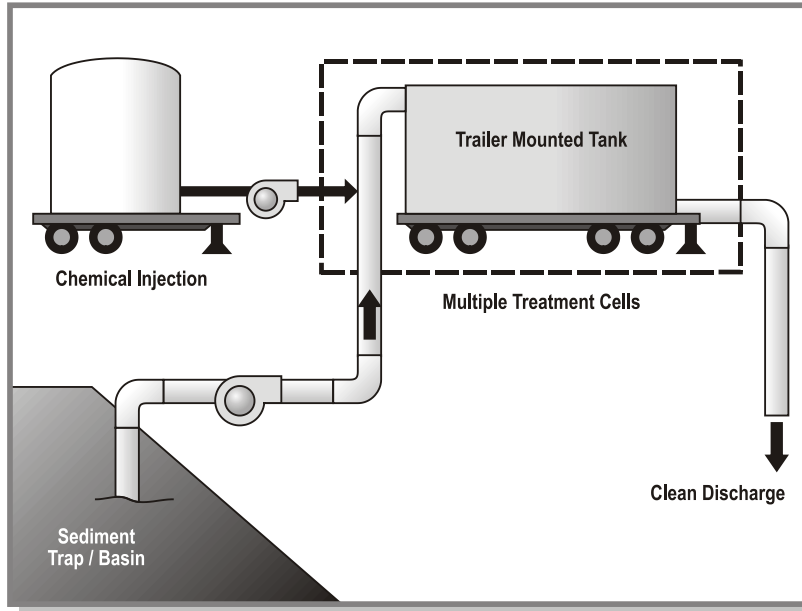

Categories

EC	Erosion Control	<input checked="" type="checkbox"/>
SE	Sediment Control	<input type="checkbox"/>
TC	Tracking Control	<input type="checkbox"/>
WE	Wind Erosion Control	<input type="checkbox"/>
NS	Non-Stormwater Management Control	<input type="checkbox"/>
WM	Waste Management and Materials Pollution Control	<input type="checkbox"/>

Legend:

- Primary Category
- Secondary Category

Targeted Constituents

Sediment	<input checked="" type="checkbox"/>
Nutrients	<input type="checkbox"/>
Trash	<input type="checkbox"/>
Metals	<input type="checkbox"/>
Bacteria	<input type="checkbox"/>
Oil and Grease	<input type="checkbox"/>
Organics	<input type="checkbox"/>

Potential Alternatives

None

If User/Subscriber modifies this fact sheet in any way, the CASQA name/logo and footer below must be removed from each page and not appear on the modified version.

Description and Purpose

Active Treatment Systems (ATS) reduce turbidity of construction site runoff by introducing chemicals to stormwater through direct dosing or an electrical current to enhance flocculation, coagulation, and settling of the suspended sediment. Coagulants and flocculants are used to enhance settling and removal of suspended sediments and generally include inorganic salts and polymers (USACE, 2001). The increased flocculation aids in sedimentation and ability to remove fine suspended sediments, thus reducing stormwater runoff turbidity and improving water quality.

Suitable Applications

ATS can reliably provide exceptional reductions of turbidity and associated pollutants and should be considered where turbid discharges to sediment and turbidity sensitive waters cannot be avoided using traditional BMPs. Additionally, it may be appropriate to use an ATS when site constraints inhibit the ability to construct a correctly sized sediment basin, when clay and/or highly erosive soils are present, or when the site has very steep or long slope lengths.

Limitations

Dischargers choosing to utilize chemical treatment in an ATS must follow all guidelines of the Construction General Permit Attachment F – Active Treatment System Requirements. General limitations are as follows:



- Numeric Effluent Limit (NEL) for all discharges (10 NTU daily flow-weighted average)
- Limited availability of chemical residual testing procedures that meet permit requirements for flow-through treatment
- Specific field and classroom ATS training required to operate equipment
- Batch treatment requires extensive toxicity testing of effluent
- Batch treatment requires large footprint to accommodate treatment cells
- Requires additional filtration to remove residual floc and treatment chemicals prior to discharge
- Petroleum based polymers should not be used
- Requires site-specific design and equipment
- Limited discharge rates depending on receiving water body
- Labor intensive operation and maintenance
- ATS costs are higher on a unit basis for smaller sites that would be expected to have a lower volume of treated runoff
- ATS costs are seasonably variable due to increases or decreases in rainfall volumes

Implementation

Turbidity is difficult to control once fine particles are suspended in stormwater runoff from a construction site. Sedimentation ponds are effective at removing larger particulate matter by gravity settling, but are ineffective at removing smaller particulates such as clay and fine silt. Sediment ponds are typically designed to remove sediment no smaller than medium silt (0.02 mm). ATS may be used to reduce the turbidity of stormwater runoff. With an ATS, very high turbidities can be reduced to levels comparable to what is found in streams during dry weather.

Criteria for ATS Product Use

Chemically treated stormwater discharged from construction sites must be non-toxic to aquatic organisms. The following protocol should be used to evaluate chemicals proposed for stormwater treatment at construction sites. Authorization to use a chemical in the field based on this protocol does not relieve the applicant from responsibility for meeting all discharge and receiving water criteria applicable to a site.

- An ATS Plan, which includes an Operation and Maintenance component, a Monitoring, Sampling and Reporting component, a Health and Safety component, and a Spill Prevention component must be prepared and submitted to the Regional Water Quality Control Board (RWQCB).

- Treatment chemicals should be approved by EPA for potable water use or otherwise be demonstrated to be protective of human health and the environment. Chemical residual or whole effluent toxicity testing is required.
- Prior to field use of chemical treatment, jar tests are to be conducted to demonstrate that turbidity reduction necessary to meet the NELs and receiving water criteria can be achieved. Test conditions, including but not limited to raw water quality and jar test procedures, should be indicative of field conditions. Although these small-scale tests cannot be expected to reproduce performance under field conditions, they are indicative of treatment capability. A minimum of six site-specific jar tests must be conducted per chemical.
- The proposed maximum dosage should be at least a factor of five lower than the no observed effects concentration (NOEC).
- Effluent discharge from an ATS to a receiving water is conditional upon the favorable results of full-scale whole effluent bioassay/toxicity testing for batch treatment systems and upon chemical residuals testing for flow-through systems.
- Contact the RWQCB for a list of treatment chemicals that may be pre-approved for use.

Active Treatment System Design Considerations

The design and operation of an ATS should take into consideration the factors that determine optimum, cost-effective performance. While site characteristics will influence system design, it is important to recognize the following overriding considerations:

- The right chemical must be used at the right dosage. A dosage that is either too low or too high will not produce the lowest turbidity. There is an optimum dosage rate. This is a situation where the adage “adding more is always better” is not the case.
- The coagulant must be mixed rapidly into the water to insure proper dispersion.
- The mixing system for batch treatment must be sized to provide adequate mixing for the design storage volume. Lack of adequate mixing during the flocculation phase results in flocs that are too small and/or insufficiently dense. Too much mixing can rapidly destroy floc as it is formed.
- Care must be taken in the design of the withdrawal system to minimize outflow velocities and to prevent floc discharge. The discharge should be directed through a filtration system such as sand, bag, or cartridge filter that would catch any unintended floc discharge.
- ATS is also regulated for pH of the discharge. A pH-adjusting chemical should be added into the treated water to control pH if the selected coagulant requires alteration of the pH of the discharge outside of the acceptable range.

Active Treatment System Design

ATS can be designed as batch treatment systems using either ponds or portable trailer-mounted tanks, or as flow-through systems using any number of proprietary designed systems.

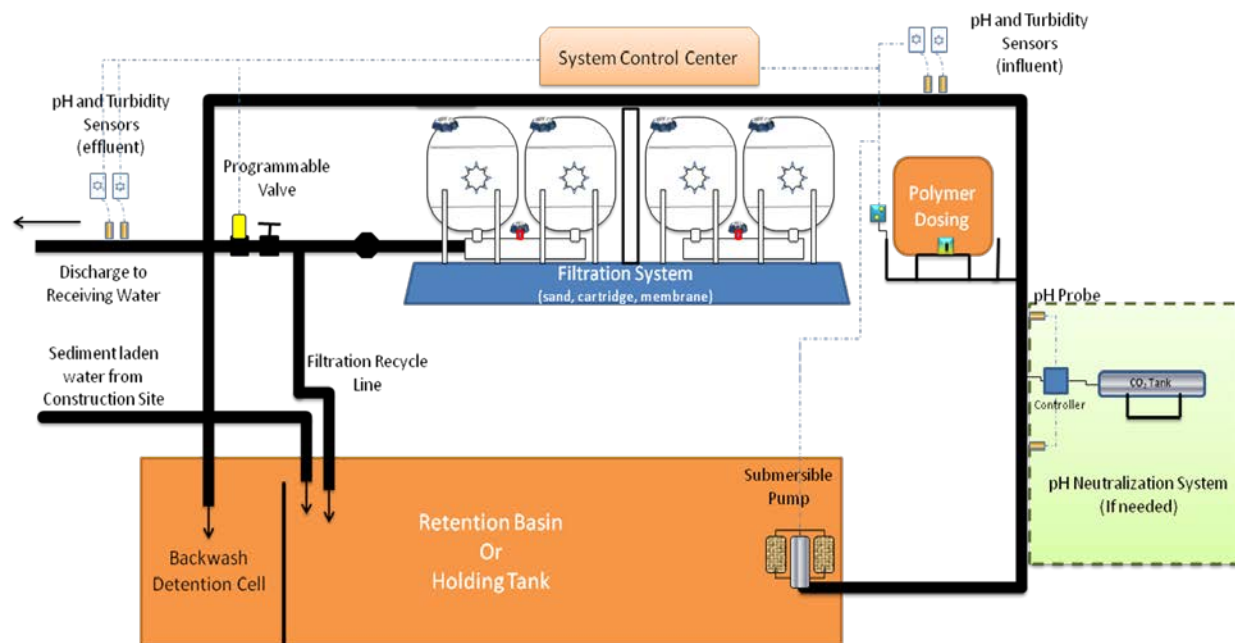

Figure has been adapted from Port of Seattle response to Washington Dept. of Ecology Action Order 2948

Batch Treatment

Batch Treatment systems consist of the stormwater collection system (either temporary diversion or the permanent site drainage system); a sediment basin, trap or holding tanks; pumps; a chemical feed system; treatment cells; and, interconnecting piping.

Batch treatment systems should use a minimum of two lined treatment cells. Multiple treatment cells allow for clarification of treated water while other cells are being filled or emptied. Treatment cells may be basins, traps, or tanks. Portable tanks may also be suitable for some sites.

The following equipment should be located in a secured, covered location:

- The chemical injector
- Secondary contaminant for acid, caustic, buffering compound, and treatment chemical
- Emergency shower and eyewash
- Monitoring equipment which consists of a pH meter and a turbidimeter (if not already within the instrumentation panel of the chemical injector)

Flow-through Treatment

At a minimum, a flow-through ATS system consists of the stormwater collection system (either temporary diversion or the permanent site drainage system), an untreated stormwater storage pond or holding tank, and a chemically enhanced filtration system.

Stormwater is collected at interception point(s) on the site and is diverted by gravity or by pumping to an untreated stormwater storage pond or other untreated stormwater holding area.

The stormwater is stored until treatment occurs. It is important that the holding pond be large enough to provide adequate storage.

Stormwater is then pumped from the untreated stormwater storage pond to the chemically enhanced filtration system where polymer is added. Adjustments to pH may be necessary before chemical addition. The filtration system continually monitors the stormwater for turbidity and pH. If the discharge water is out of the acceptable turbidity or pH range, the water is recycled to the untreated stormwater pond (or holding tank) where it can be retreated. Flow through systems must ensure that:

- Cumulative flow volume shall be recorded daily. The data recording system shall have the capacity to record a minimum of seven days of continuous data.
- Instrumentation systems are interfaced with system control to provide auto shutoff or recirculation in the event that effluent measurements exceed turbidity or pH.
- Upon system upset, power failure, or other catastrophic event, the ATS will default to a recirculation mode or safe shut down.
- The instrumentation system provides a method for controlling coagulant dose, to prevent potential overdosing.

Sizing Criteria

An ATS shall be designed and approved by a Certified Professional in Erosion and Sediment Control (CPESC), a Certified Professional in Storm Water Quality (CPSWQ); a California registered civil engineer; or any other California registered engineer.

ATS must be designed to capture and treat (within 72 hours) runoff from the 10-year 24-hour storm event. The runoff volume of the watershed area to be treated from this size storm event is required to be calculated using the Rational Method with a runoff coefficient of 1.

If sediment basins are used to capture flow-through or batch treatment, see SE-2, Sediment Basin, for design criteria. Bypass should be provided around the ATS to accommodate extreme storm events. Primary settling should be encouraged in the sediment basin/storage pond. A forebay with access for maintenance may be beneficial.

The permissible discharge rate governed by potential downstream effect should be used to calculate the recommended size of the treatment cells. Local requirements related to Phase I or Phase II NPDES permit thresholds should be considered in developing maximum discharge rates the ATS Plan.

Costs

Costs for ATS may be significant due to equipment rental requirements and cost of chemicals. ATS cost is lower on a treated unit-basis for large construction sites with large volumes of runoff.

Inspection and Maintenance

ATS must be operated and maintained by individuals with experience in their use and trained in accordance with training requirements below. ATS should be monitored continuously while in

use. A designated responsible person shall be on site daily at all times during treatment operations. Daily on-site visual monitoring of the system for proper performance shall be conducted and recorded in the project data log. The name, phone number, and training documentation of the person responsible for system operation and monitoring shall be included in the project data log.

The following monitoring requirements and results should be recorded in the data log:

Operational and Compliance Monitoring

- Effluent flow rate and volume shall be continuously monitored and recorded at 15- minute or less intervals.
- Influent and effluent pH must be continuously monitored and recorded at 15-minute or less intervals.
- Influent and effluent turbidity (expressed in NTU) must be continuously monitored and recorded at 15-minute or less intervals.
- The type and amount of chemical used for pH adjustment, if any, shall be monitored and recorded.
- Dose rate of chemical used in the ATS system (expressed in mg/L) shall be monitored and reported 15-minutes after startup and every 8 hours of operation.
- Laboratory duplicates – monthly laboratory duplicates for residual coagulant analysis must be performed and records shall be maintained onsite.
- Effluent shall be monitored and recorded for residual chemical/additive levels.
- If a residual chemical/additive test does not exist and the ATS is operating in a batch treatment mode of operation refer to the toxicity monitoring requirements below.

Toxicity Monitoring

Batch Treatment

Toxicity testing for systems operated in batch treatment mode should be made in accordance with the following:

- Acute toxicity testing on effluent samples representing effluent from each batch prior to discharge shall be undertaken. All bioassays shall be sent to a laboratory certified by the Department of Health Services (DHS) Environmental Laboratory Accreditation Program (ELAP). The required field of testing number for Whole Effluent Toxicity (WET) testing is E113.
- Acute toxicity tests shall be conducted with the following species and protocols. The methods to be used in the acute toxicity testing shall be those outlined for a 96-hour acute test in “Methods for Measuring the Acute Toxicity of Effluents and Receiving Water to Freshwater and Marine Organisms, USEPA-841-R-02-012” for Fathead minnow, *Pimephales promelas*. Rainbow trout, *Oncorhynchus mykiss*, may be used as a substitute for fathead minnow.

All toxicity tests shall meet quality assurance criteria and test acceptability criteria in the most recent versions of the EPA test method for WET testing.

Flow-through Treatment

Toxicity testing for systems operated in flow-through treatment mode should be made in accordance with the following:

- A residual chemical test method shall be used that has a method detection limit (MDL) of 10% or less than the maximum allowable threshold concentration (MATC) for the specific coagulant in use and for the most sensitive species of the chemical used. The MATC is equal to the geometric mean of the No Observed Effect Concentration (NOEC) and Lowest Observed Effect Concentration (LOEC) Acute and Chronic toxicity results for most sensitive species determined for the specific coagulant.
- The residual chemical test method shall produce a result within one hour of sampling.
- A California State certified laboratory shall validate the selected residual chemical test. Specifically the lab will review the test protocol, test parameters, and the detection limit of the coagulant. The discharger shall electronically submit this documentation as part of the ATS Plan.

Numeric Effluent Limit (NEL) Compliance:

All chemically treated stormwater must be sampled and tested for compliance with pH and turbidity limits. These limits have been established by the Construction General Permit. Sampling and testing for other pollutants may also be necessary at some sites. Turbidity limits have been set as 10 NTU as a daily flow-weighted average or 20 NTU from a single sample. pH must be within the range of 6.0 to 9.0 standard units. It is often possible to discharge treated stormwater that has a lower turbidity than the receiving water and that matches the pH.

Treated stormwater samples and measurements should be taken from the discharge pipe or another location representative of the nature of the treated stormwater discharge. Samples used for determining compliance with the water quality standards in the receiving water should not be taken from the treatment pond prior to decanting. Compliance with the water quality standards is determined in the receiving water.

Operator Training:

Operators shall have training specific to using an ATS and liquid coagulants for stormwater discharges in California. The training shall be in the form of a formal class with a certificate and requirements for testing and certificate renewal. Training shall include a minimum of eight hours classroom and 32 hours field training.

Standard BMPs:

Erosion and sediment control BMPs should be implemented throughout the site to prevent erosion and discharge of sediment to the ATS. Some types of chemical coagulation and flocculation are only achievable in water below a certain turbidity; therefore minimizing the amount of sediment reaching the system will increase the likelihood of meeting effluent limits and will potentially lower costs of chemical dosing.

Sediment Removal and Disposal

- Sediment shall be removed from the storage or treatment cells as necessary to ensure that the cells maintain their required water storage (i.e., volume) capability.
- Handling and disposal of all solids generated during ATS operations shall be done in accordance with all local, state, and federal laws and regulations.
- If sediment is determined to be non-toxic, it may be incorporated into the site away from drainages.

References

Engineering and Design – Precipitation/Coagulation/Flocculation. United States Army Corps of Engineers, EM 1110-1-4012, 2001.

Evaluation of Active Treatment Systems (ATS) for Construction Site Runoff. California Building and Industry Association (prepared by Geosyntec Consultants), 2008.

Stormwater Management Manual for Western Washington, Volume II – Construction Stormwater Pollution Prevention, Washington State Department of Ecology, August 2001.

Stormwater Quality Handbooks - Construction Site Best Management Practices (BMPs) Manual, State of California Department of Transportation (Caltrans), November 2000.

Manufactured Linear Sediment Controls (MLSC)

SE-12



Description and Purpose

Manufactured linear sediment controls (MLSC) are pre-manufactured devices that are typically specified and installed for drainage and sediment control on the perimeter of disturbed sites or stockpiles and as check dams within channels. Typically, MLSCs can be reused.

This fact sheet is intended to provide guidance on BMP selection and implementation of proprietary or vendor-supplied products, for sediment control. Products should be evaluated for project-specific implementation and used if determined to be appropriate by the SWPPP Preparer.

Suitable Applications

MLSCs are generally used in areas as a substitute for fiber rolls and silt fences in sediment control applications to slow down runoff water, divert drainage or contain fines and sediment. MLSCs are a linear control and application suitability varies based on the specific product type. They may be suitable:

- On paved surfaces for perimeter protection.
- As check structures in channels.
- Along the perimeter of disturbed sites in lieu of silt fence.

Categories

EC	Erosion Control	<input checked="" type="checkbox"/>
SE	Sediment Control	<input checked="" type="checkbox"/>
TC	Tracking Control	
WE	Wind Erosion Control	
NS	Non-Stormwater Management Control	
WM	Waste Management and Materials Pollution Control	<input checked="" type="checkbox"/>

Legend:

- Primary Category
- Secondary Category

Targeted Constituents

Sediment	<input checked="" type="checkbox"/>
Nutrients	
Trash	<input checked="" type="checkbox"/>
Metals	
Bacteria	
Oil and Grease	
Organics	

Potential Alternatives

- SE-1 Silt Fence
- SE-5 Fiber Roll
- SE-6 Gravel Bag Berm
- SE-8 Sandbag Barrier

If User/Subscriber modifies this fact sheet in any way, the CASQA name/logo and footer below must be removed from each page and not appear on the modified version.



Manufactured Linear Sediment Controls (MLSC)

SE-12

- At operational storm drains as a form of inlet protection.
- Around temporary stockpiles or material/equipment storage areas.
- At the interface between graveled driveways and pavement.
- Along the toe of exposed and erodible slopes.

Limitations

- Limitations vary by product. Product manufacturer's printed product use instructions should be reviewed by the SWPPP Preparer to determine the project-specific applicability of MLSCs.

Implementation

General

When appropriately placed, MLSCs intercept and slow sheet flow runoff, causing temporary ponding. The temporary ponding provides quiescent conditions allowing sediment to settle. The device is porous, which allows the ponded runoff to flow slowly through the device, releasing the runoff as sheet flows. Generally, MLSCs should be used in conjunction with temporary soil stabilization controls up-slope to provide an effective combination of erosion and sediment control.

Design and Layout

- MLSCs used on soil should be trenched or attached to the ground per manufacturer specifications in a manner that precludes runoff or ponded water from flowing around or under the device.
- MLSCs designed for use on asphalt or concrete may be attached using a variety of methods, including nailing the device to the pavement, or using a high strength adhesive.
- Follow manufacturer written specifications when installing MLSCs.
- Allow sufficient space up-slope from the silt dike to allow ponding, and to provide room for sediment storage.
- For installation near the toe of the slope, MLSCs should be set back 3 feet from the slope toe to facilitate cleaning. Where site conditions do not allow set back, the sediment control may be constructed on the toe of the slope. To prevent flows behind the barrier, sand or gravel bags can be placed perpendicular and between the sediment control and slope to serve as a barrier to parallel flow.
- Drainage area should not exceed 5 acres.

Materials

- Several manufactured products are available. The following search terms or combination of terms can be used with an internet search engine to find manufactured linear sediment controls:

Manufactured Linear Sediment Controls (MLSC)

SE-12

- “silt barrier”
- “reusable silt fence”
- “silt fence alternative” or
- “perimeter sediment control”

Costs

Manufacturers should be contacted directly for current pricing.

Inspection and Maintenance

- BMPs must be inspected in accordance with General Permit requirements for the associated project type and risk level. It is recommended that at a minimum, BMPs be inspected weekly, prior to forecasted rain events, daily during extended rain events, and after the conclusion of rain events.
- Reshape or replace sections of damaged MLSCs as needed.
- Repair washouts or other damage as needed.
- Sediment that accumulates behind the BMP should be periodically removed in order to maintain BMP effectiveness. Sediment should be removed when the sediment accumulation reaches one-third of the barrier height.
- Remove MLSCs when no longer needed. Remove sediment accumulation and clean, re-grade, and stabilize the area. Removed sediment should be incorporated in the project or disposed of properly.

References

City of Elko Construction Site Best Management Practices Handbook, December 2005.

Construction Site Best Management Practices Handbook, June 2008 Update, Truckee Meadows Regional Stormwater Quality Management Program, June 2008.

Complying with the Edwards Aquifer Rules Technical Guidance on Best Management Practices, Texas Commission on Environmental Quality, Revised July 2005, Addendum Sheet, January 26, 2011.

Stormwater Management Manual for Western Washington Volume II, Construction Stormwater Pollution Prevention, Washington State Department of Ecology, February 2005.



Description and Purpose

Compost socks and berms act as three-dimensional biodegradable filtering structures to intercept runoff where sheet flow occurs and are generally placed at the site perimeter or at intervals on sloped areas. Compost socks are generally a mesh sock containing compost and a compost berm is a dike of compost, trapezoidal in cross section. When employed to intercept sheet flow, both BMPs are placed perpendicular to the flow of runoff, allowing filtered runoff to pass through the compost and retaining sediment (and potentially other pollutants). A compost sock can be assembled on site by filling a mesh sock (e.g. with a pneumatic blower). The compost berm should be constructed using a backhoe or equivalent and/or a pneumatic delivery (blower) system and should be properly compacted. Compost socks and berms act as filters, reduce runoff velocities, and in some cases, aid in establishing vegetation.

Compost is organic, biodegradable, and renewable. Compost provides soil structure that allows water to infiltrate the compost medium which helps prevent rill erosion and the retained moisture promotes seed germination and vegetation growth, in addition to providing organic matter and nutrients important for fostering vegetation. Compost improves soil quality and productivity, as well as erosion and sediment control.

Categories

EC	Erosion Control	<input checked="" type="checkbox"/>
SE	Sediment Control	<input checked="" type="checkbox"/>
TC	Tracking Control	
WE	Wind Erosion Control	
NS	Non-Stormwater Management Control	
WM	Waste Management and Materials Pollution Control	

Legend:

- Primary Category
- Secondary Category

Targeted Constituents

Sediment	<input checked="" type="checkbox"/>
Nutrients	
Trash	
Metals	<input checked="" type="checkbox"/>
Bacteria	<input checked="" type="checkbox"/>
Oil and Grease	<input checked="" type="checkbox"/>
Organics	

Potential Alternatives

- SE-1 Silt Fence
- SE-5 Fiber Roll
- SE-6 Gravel Bag Berm
- SE-8 Sandbag Barrier
- SE-14 Biofilter Bags

If User/Subscriber modifies this fact sheet in any way, the CASQA name/logo and footer below must be removed from each page and not appear on the modified version.



The compost of the compost sock or berm can be selected that targets site specific objectives in capturing sediment and other pollutants, supporting vegetation, or additional erosion control.

Compost is typically derived from combinations of feedstocks, biosolids, leaf and yard trimmings, manure, wood, or mixed solid waste. Many types of compost are products of municipal recycle or "Greenwaste" programs. Compost is organic and biodegradable and can be left onsite. There are many types of compost with a variety of properties with specific functions, and accordingly compost selection is an important design consideration in the application of this type of erosion and sediment control.

Suitable Applications

- Along the toe, top, face, and at grade breaks of exposed and erodible slopes to shorten slope length and spread runoff as sheet flow (compost berms should only be used at the top of slopes or on slopes 4:1 (H:V) or flatter, all other slope applications should use compost socks)
- Along the perimeter of a project
- As check dams in unlined ditches (compost socks only)
- Down-slope of exposed soil areas
- At operational storm drains as a form of inlet protection (compost socks only)
- Around temporary stockpiles

Compost socks and berms do not require special trenching or BMP removal compared to other sediment control methods (e.g. silt fence or fiber rolls). Compost socks and berms can remain in place after earth disturbing activities are completed or the compost components can be spread over the site providing nutrients for plant growth and augmenting soil structure. BMPs that remain in place are particularly advantageous below embankments, especially adjacent streams, by limiting re-entry and the disturbance to sensitive areas.

Compost can be pre-seeded prior to application (recommended by the EPA for construction site stormwater runoff control and required for compost socks) or seeded after installation (for compost berms only). The compost medium can also remove pollutants in stormwater including heavy metals; oil and grease; and hydrocarbons.

Limitations

- Compost can potentially leach nutrients (dissolved phosphorus and nitrogen) into runoff and potentially impact water quality. Compost should not be used directly upstream from nutrient impaired waterbodies (Adams et. al, 2008).
- Compost may also contain other undesirable constituents that are detrimental to water quality. Compost should be obtained from a supplier certified by the California Integrated Waste Management Board or compost should otherwise meet the environmental health standards of Title 14, California Code of Regulations, Division 7, Chapter 3.1, Article 7. Carefully consider the qualifications and experience of any compost producer/supplier.

- Application by hand is more time intensive and potentially costly. Using a pneumatic blower truck is the recommended cost effective method of assembly.
- Compost socks and berms should not be employed at the base of slopes greater than 2:1 (H:V). They can be employed with other erosion control methods for steeper slopes.
- Difficult to move once saturated.
- Compost berms should not be applied in areas of concentrated flows.
- Compost socks and berms are easy to fix; however, they are susceptible to damage by frequent traffic. Compost socks can be used around heavy machinery, but regular disturbance decreases sock performance.

Implementation

Compost Materials

- California Compost Regulations (Title 14, California Code of Regulations, Division 7, Chapter 3.1, Article 7, Section 17868.3) define and require a quality of compost for application. Compost should comply with all physical and chemical requirements. Specific requirements are provided in **Table 1**, taken from Caltrans Standard Special Provision 10-1 (SSP 10-1), Erosion Control (Compost Blanket).
- The compost producer should be fully permitted as specified under the California Integrated Waste Management Board, Local Enforcement Agencies and any other State and Local Agencies that regulate Solid Waste Facilities. If exempt from State permitting requirements, the composting facility should certify that it follows guidelines and procedures for production of compost meeting the environmental health standards of Title 14, California Code of Regulations, Division 7, Chapter 3.1, Article 7.
- The compost producer should be a participant in United States Composting Council's Seal of Testing Assurance program.
- Compost medium parameter specifications for compost socks and berms have been developed to assist in compost selection, such as those provided by the American Association of State Highway Transportation Officials (AASHTO).
- Particle size is important parameter for selecting compost. Well consolidated coarser grades of compost (e.g. small and large pieces) perform better for filtration objectives, while finer grades better support vegetation. Particle size of the compost should be selected based on site conditions, such as expected precipitation, and filtration goals and / or long term plant nutrients.
- Compost moisture should be considered for composition quality and application purposes. A range of 30-50% is typical. Compost that is too dry is hard to apply and compost that is too wet is more difficult (and more expensive) to transport. For arid or semi-arid areas, or for application during the dry season, use compost with greater moisture content than areas with wetter climates. For wetter or more humid climates or for application during the wet season, drier composts can be used as the compost will absorb moisture from the ambient air.

- If vegetation establishment is a desired function of the compost, a compost sample should be inspected by a qualified individual. Vegetation has different nutrient and moisture needs.
- Organic content of the compost is also important and should range from 30 to 65% depending on site conditions.
- Compost should not be derived from mixed municipal solid waste and should be reasonably free of visible contaminants.
- Compost should not contain paint, petroleum products, pesticides or any other chemical residues harmful to animal life or plant growth. Metal concentrations in compost should not exceed the maximum metal concentrations listed under Title 14, California Code of Regulations, Division 7, Chapter 3.1, Section 17868.2.
- Compost should not possess objectionable odors.
- Compost should be weed free.

Table 1. Physical/Chemical Requirements of Compost
Reference - Caltrans SSP-10 Erosion Control Blanket (Compost)

Property	Test Method	Requirement
pH	*TMECC 04.11-A Elastometric pH 1:5 Slurry Method pH Units	6.0–8.0
Soluble Salts	TMECC 04.10-A Electrical Conductivity 1:5 Slurry Method dS/m (mmhos/cm)	0-10.0
Moisture Content	TMECC 03.09-A Total Solids & Moisture at 70+/- 5 deg C % Wet Weight Basis	30-60
Organic Matter Content	TMECC 05.07-A Loss-On-Ignition Organic Matter Method (LOI) % Dry Weight Basis	30–65
Maturity	TMECC 05.05-A Germination and Vigor Seed Emergence Seedling Vigor % Relative to Positive Control	80 or Above 80 or Above
Stability	TMECC 05.08-B Carbon Dioxide Evolution Rate mg CO ₂ -C/g OM per day	8 or below
Particle Size	TMECC 02.02-B Sample Sieving for Aggregate Size Classification % Dry Weight Basis	100% Passing, 3 inch 90-100% Passing, 1 inch 65-100% Passing, 3/4 inch 0 - 75% Passing, 1/4 inch Maximum length 6 inches
Pathogen	TMECC 07.01-B Fecal Coliform Bacteria < 1000 MPN/gram dry wt.	Pass
Pathogen	TMECC 07.01-B Salmonella < 3 MPN/4 grams dry wt.	Pass
Physical Contaminants	TMECC 02.02-C Man Made Inert Removal and Classification: Plastic, Glass and Metal % > 4mm fraction	Combined Total: < 1.0
Physical Contaminants	TMECC 02.02-C Man Made Inert Removal and Classification: Sharps (Sewing needles, straight pins and hypodermic needles) % > 4mm fraction	None Detected

*TMECC refers to "Test Methods for the Examination of Composting and Compost," published by the United States Department of Agriculture and the United States Compost Council (USCC).

Installation

- Prior to application, prepare locations for socks and berms by removing brush and thick vegetation. The compost of the sock and/or berm should be allowed to come in full contact with the ground surface.
- Select method to apply the compost sock or berm. A pneumatic blower is most cost effective and most adaptive in applying compost to steep, rough terrain, and hard to reach locations.
- The compost of the berm should be distributed evenly to the surface, compacted, and shaped trapezoidal in cross section. Berm design is generally consists of a base two times the height. AASHTO specification MP 9-03 provides compost berm dimensions based on anticipated

site precipitation (AASHTO, 2003 and USEPA, 2009). State agencies, such as Oregon Department of Environmental Quality (ODEQ) have developed berm dimension based on slope steepness and length (ODEQ, 2004).

- Compost socks can be assembled on site by filling mesh socks with the selected compost. Mesh socks can be tied at one end, filled, and then tied at the other end. The ends of socks can be interlocked until the desired length is achieved. The sock diameter is a function of slope steepness and length. Again, ASSHTO provides specifications for various parameters. Compost socks range from 8" to 18", but are typically 12" to 18" in diameter.
- Compost socks are typically placed in contours perpendicular to sheet flow. They can also be placed in V formation on a slope. Compost socks need to be anchored, typically stakes, through the center of the sock. To prevent water flowing around them, the ends of compost socks should be placed upslope.
- Locate compost socks and berms on level contours spaced as follows:
 - Slope inclination of 4:1 (H:V) or flatter: Socks and/or berms should be placed at a maximum interval of 20 ft.
 - Slope inclination between 4:1 and 2:1 (H:V): Socks should be placed at a maximum interval of 15 ft. (a closer spacing is more effective).
 - Slope inclination 2:1 (H:V) or greater: Socks should be placed at a maximum interval of 10 ft. (a closer spacing is more effective).
- Place perimeter socks and berms using a j-hook installation. Use of vegetation will also provide additional anchoring.
- Compost socks and berms can be placed around the perimeter of an affected area, like a silt fence, if the area is flat or on a contour. Do not place these socks and berms where ponded water could become an issue.
- If used at the toe of slopes, the compost sock or berm should at a minimum of 5 to 10 feet away.
- Use additional anchoring and erosion control BMPs in conjunction of the compost socks and berms as needed.
- Consider using compost berms or socks as necessary at the top and/or bottom of the slope for additional erosion control performance.
- Compost socks and berms can also be effective over rocky and frozen ground if installed properly.
- It is recommended that the drainage areas of these compost BMPs do not exceed 0.25 acre per 100 feet placement interval and runoff does not exceed 1 cubic foot per second.

Costs

Recently obtained vendor costs indicated \$3.50 per linear foot for compost berm application and \$2.00 per linear foot for 8" socks and \$2.50 per linear foot for 12" socks. Costs do not include final compost sock or berm functions at the end of construction activities, including spreading or removal, if required. ODEQ estimates that compost berms cost 30 percent less than silt fences to install.

Inspection and Maintenance

- BMPs must be inspected in accordance with General Permit requirements for the associated project type and risk level. It is recommended that at a minimum, BMPs be inspected weekly, prior to forecasted rain events, daily during extended rain events, and after the conclusion of rain events.
- Once damage is identified, mend or reapply the sock or berm as needed. Washed out areas should be replaced. If the sock or berm height is breached during a storm, an additional sock can be stacked to increase the sock height and similarly the berm dimensions can be increased, as applicable. An additional sock or berm may be installed upslope, as needed. It may be necessary to apply an additional type of stormwater BMP, such as a compost blanket.
- Sediment contained by the sock or berm should be removed prior reaching 1/3 of the exposed height of the BMP. The sediment can be stabilized with the compost sock or berm with vegetation at the end of construction activities.
- Care should be exercised to minimize the damage to protected areas while making repairs, as any area damaged will require reapplication of BMPs.
- Limit traffic to minimize damage to BMPs or impede vegetation establishment.

References

An analysis of Composting as an Environmental Remediation Technology, U.S. Environmental Protection Agency (USEPA), Solid Waste and Emergency Response (5305W), EPA530-R-8-008, 1998.

Characteristics of Compost: Moisture Holding and Water Quality Improvement, Center for Research in Water Resources, Kirchoff, C., Malina, J., and Barrett, M., 2003.

Compost Utilization for Erosion Control, The University of Georgia College of Agricultural and Environmental Sciences, pubs.caes.uga.edu/caespubs/pubcd/B1200.htm, Faucette, B. and Risse, M., 2001.

Erosion and Sediment Control Manual, Oregon Department of Environmental Quality, February 2005.

Standard Special Provision 10-1, Erosion Control (Compost Blanket), State of California Department of Transportation (Caltrans). 2007 Update.

Evaluation of Environmental Benefits and Impacts of Compost and Industry Standard Erosion and Sediment Controls Measures Used in Construction Activities, Dissertation, Institute of Ecology, University of Georgia, Faucette, B., 2004.

National Pollutant Discharge Elimination System (NPDES), Compost Blankets, U.S. Environmental Protection Agency (USEPA).

http://cfpub.epa.gov/npdes/stormwater/menuofbmps/index.cfm?action=factsheet_results&view=specific&bmp=118, 2009.

Standard Specifications for Transportation Materials and Methods of Sampling and Testing, Designation MP-9, Compost for Erosion/Sediment Control (Filter Berms), Provisional, American Association of State Highway Transportation Officials (AASHTO), 2003.

Stormwater Best Management Practices (BMPs) Field Trials of Erosion Control Compost in Reclamation of Rock Quarry Operations, Nonpoint Source Protection Program CWA §319(h), Texas Commission on Environmental Quality, Adams, T., McFarland, A., Hauck, L., Barrett, M., and Eck, B., 2008.



Description and Purpose

Biofilter bags, or bio-bags, are a multi-purpose sediment control BMP consisting of a plastic mesh bag filled with 100% recycled wood product waste. Biofilter bags come in a variety of sizes (30" x 18" and 30" x 9" being common) and generally have between 1-2 cubic yards of recycled wood waste (or wood chips). Biofilter bags work by detaining flow and allowing a slow rate of discharge through the wood media. This action removes suspended sediment through gravity settling of the detained water and filtration within the bag.

Suitable Applications

Biofilter bags are a short-term BMP that can be rapidly deployed, maintained, and replaced. Biofilter bags can be an effective short-term solution to place in developed rills to prevent further erosion until permanent measures can be established. Suitable short-term applications include:

- As a linear sediment control measure:
 - Below the toe of slopes and erodible slopes
 - Below other small cleared areas
 - Along the perimeter of a site (with low-expected flow)
 - Down slope of exposed soil areas
 - Around temporary stockpiles and spoil areas
 - Parallel to a roadway to keep sediment off paved areas

Categories

EC	Erosion Control	
SE	Sediment Control	<input checked="" type="checkbox"/>
TR	Tracking Control	
WE	Wind Erosion Control	
NS	Non-Stormwater Management Control	
WM	Waste Management and Materials Pollution Control	

Legend:

- Primary Category
- Secondary Category

Targeted Constituents

Sediment	<input checked="" type="checkbox"/>
Nutrients	
Trash	
Metals	
Bacteria	
Oil and Grease	
Organics	

Potential Alternatives

- SE-1 Silt Fence
- SE-4 Check Dams
- SE-5 Fiber Roll
- SE-6 Gravel Bag Berm
- SE-8 Sandbag Barrier
- SE-10 Storm Drain Inlet Protection

If User/Subscriber modifies this fact sheet in any way, the CASQA name/logo and footer below must be removed from each page and not appear on the modified version.



- Along streams and channels
- As linear erosion control measure:
 - Along the face and at grade breaks of exposed and erodible slopes to shorten slope length and spread runoff as sheet flow
 - At the top of slopes to divert runoff away from disturbed slopes
 - As check dams across mildly sloped construction roads
- Inlet Protection (See SE-10)
- Supplement to silt fences or other sediment control devices

Limitations

- Short life-span (maximum usefulness of 2-3 months and should be replaced more frequently if needed); regular maintenance and replacement required to ensure effectiveness. Bags will rapidly fill with sediment and reduce permeability.
- Easily damaged by construction vehicles.
- If not properly staked, will fail on slope applications.
- If improperly installed can allow undercutting or side-cutting flow.
- Not effective where water velocities or volumes are high.
- Potentially buoyant and easily displaced if not properly installed.

Implementation

General

Biofilter bags are a relatively low cost temporary BMP that are easily deployed and have a simple installation that can be performed by hand. Without proper installation, however, biofilter bags can fail due to their light weight, potential displacement, and multiple joint locations. One of the benefits of utilizing biofilter bags is that the media (wood-product) can be recycled or used onsite when no longer needed (where acceptable).

Design and Layout – Linear control

- Locate biofilter bags on level contours.
 - Slopes between 20:1 and 4:1 (H:V): Biofilter bags should be placed at a maximum interval of 20 ft, with the first row near the slope toe.
 - Slopes between 4:1 and 2:1 (H:V): Biofilter bags should be placed at a maximum interval of 15 ft, with the first row near the slope toe.
 - Slopes 2:1 (H:V) or steeper: Biofilter bags should be placed at a maximum interval of 10 ft., with the first row placed the slope toe.

- Turn the ends of the biofilter bag barriers up slope to prevent runoff from going around the berm.
- Allow sufficient space up slope from the biofilter bag berm to allow ponding, and to provide room for sediment storage.
- Stake biofilter bags into a 1 to 2 in. deep trench with a width equal to the bag.
 - Drive one stake at each end of the bag.
 - Use wood stakes with a nominal classification of 0.75 by 0.75 in. and minimum length of 24 in.
- Biofilter bags should be overlapped (6 in.), not abutted.

Costs

Pre-filled biofilter bags cost approximately \$2.50-\$3.50 per bag, dependent upon size.

Inspection and Maintenance

- BMPs must be inspected in accordance with General Permit requirements for the associated project type and risk level. It is recommended that at a minimum, BMPs be inspected weekly, prior to forecasted rain events, daily during extended rain events, and after the conclusion of rain events.
- Biofilter bags exposed to sunlight will need to be replaced every two to three months due to degrading of the bags.
- Reshape or replace biofilter bags as needed.
- Repair washouts or other damage as needed.
- Sediment that is retained by the BMP should be periodically removed in order to maintain BMP effectiveness. Sediment should be removed when the sediment accumulation reaches one-third of the barrier height.
- Remove biofilter bag berms when no longer needed. Remove sediment accumulation and clean, re-grade, and stabilize the area. Biofilter media may be used on-site, if allowed.

References

Catalog of Stormwater Best Management Practices for Idaho Cities and Counties. Volume 2, Section 7, BMP 34 – Biofilter Bags, Idaho Department of Environmental Quality, 2005.

Erosion and Sediment Control Manual, Oregon Department of Environmental Quality, February 2005.

Stormwater Quality Handbooks Construction Site Best Management Practices (BMPs) Manual, State of California Department of Transportation (Caltrans), March 2003.

Stabilized Construction Entrance/Exit TC-1

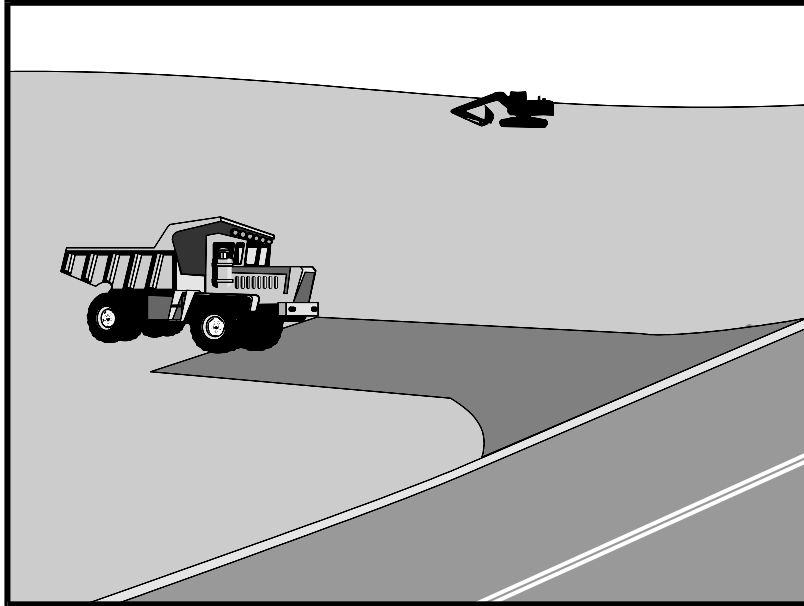

Description and Purpose

A stabilized construction access is defined by a point of entrance/exit to a construction site that is stabilized to reduce the tracking of mud and dirt onto public roads by construction vehicles.

Suitable Applications

Use at construction sites:

- Where dirt or mud can be tracked onto public roads.
- Adjacent to water bodies.
- Where poor soils are encountered.
- Where dust is a problem during dry weather conditions.

Limitations

- Entrances and exits require periodic top dressing with additional stones.
- This BMP should be used in conjunction with street sweeping on adjacent public right of way.
- Entrances and exits should be constructed on level ground only.
- Stabilized construction entrances are rather expensive to construct and when a wash rack is included, a sediment trap of some kind must also be provided to collect wash water runoff.

Categories

EC	Erosion Control	<input checked="" type="checkbox"/>
SE	Sediment Control	<input checked="" type="checkbox"/>
TC	Tracking Control	<input checked="" type="checkbox"/>
WE	Wind Erosion Control	
NS	Non-Stormwater Management Control	
WM	Waste Management and Materials Pollution Control	

Legend:

- Primary Objective
- Secondary Objective

Targeted Constituents

Sediment	<input checked="" type="checkbox"/>
Nutrients	
Trash	
Metals	
Bacteria	
Oil and Grease	
Organics	

Potential Alternatives

None

If User/Subscriber modifies this fact sheet in any way, the CASQA name/logo and footer below must be removed from each page and not appear on the modified version.



Stabilized Construction Entrance/Exit TC-1

Implementation

General

A stabilized construction entrance is a pad of aggregate underlain with filter cloth located at any point where traffic will be entering or leaving a construction site to or from a public right of way, street, alley, sidewalk, or parking area. The purpose of a stabilized construction entrance is to reduce or eliminate the tracking of sediment onto public rights of way or streets. Reducing tracking of sediments and other pollutants onto paved roads helps prevent deposition of sediments into local storm drains and production of airborne dust.

Where traffic will be entering or leaving the construction site, a stabilized construction entrance should be used. NPDES permits require that appropriate measures be implemented to prevent tracking of sediments onto paved roadways, where a significant source of sediments is derived from mud and dirt carried out from unpaved roads and construction sites.

Stabilized construction entrances are moderately effective in removing sediment from equipment leaving a construction site. The entrance should be built on level ground. Advantages of the Stabilized Construction Entrance/Exit is that it does remove some sediment from equipment and serves to channel construction traffic in and out of the site at specified locations. Efficiency is greatly increased when a washing rack is included as part of a stabilized construction entrance/exit.

Design and Layout

- Construct on level ground where possible.
- Select 3 to 6 in. diameter stones.
- Use minimum depth of stones of 12 in. or as recommended by soils engineer.
- Construct length of 50 ft or maximum site will allow, and 10 ft minimum width or to accommodate traffic.
- Rumble racks constructed of steel panels with ridges and installed in the stabilized entrance/exit will help remove additional sediment and to keep adjacent streets clean.
- Provide ample turning radii as part of the entrance.
- Limit the points of entrance/exit to the construction site.
- Limit speed of vehicles to control dust.
- Properly grade each construction entrance/exit to prevent runoff from leaving the construction site.
- Route runoff from stabilized entrances/exits through a sediment trapping device before discharge.
- Design stabilized entrance/exit to support heaviest vehicles and equipment that will use it.

Stabilized Construction Entrance/Exit TC-1

- Select construction access stabilization (aggregate, asphaltic concrete, concrete) based on longevity, required performance, and site conditions. Do not use asphalt concrete (AC) grindings for stabilized construction access/roadway.
- If aggregate is selected, place crushed aggregate over geotextile fabric to at least 12 in. depth, or place aggregate to a depth recommended by a geotechnical engineer. A crushed aggregate greater than 3 in. but smaller than 6 in. should be used.
- Designate combination or single purpose entrances and exits to the construction site.
- Require that all employees, subcontractors, and suppliers utilize the stabilized construction access.
- Implement SE-7, Street Sweeping and Vacuuming, as needed.
- All exit locations intended to be used for more than a two-week period should have stabilized construction entrance/exit BMPs.

Inspection and Maintenance

- Inspect and verify that activity-based BMPs are in place prior to the commencement of associated activities. While activities associated with the BMPs are under way, inspect BMPs in accordance with General Permit requirements for the associated project type and risk level. It is recommended that at a minimum, BMPs be inspected weekly, prior to forecasted rain events, daily during extended rain events, and after the conclusion of rain events.
- Inspect local roads adjacent to the site daily. Sweep or vacuum to remove visible accumulated sediment.
- Remove aggregate, separate and dispose of sediment if construction entrance/exit is clogged with sediment.
- Keep all temporary roadway ditches clear.
- Check for damage and repair as needed.
- Replace gravel material when surface voids are visible.
- Remove all sediment deposited on paved roadways within 24 hours.
- Remove gravel and filter fabric at completion of construction

Costs

Average annual cost for installation and maintenance may vary from \$1,200 to \$4,800 each, averaging \$2,400 per entrance. Costs will increase with addition of washing rack, and sediment trap. With wash rack, costs range from \$1,200 - \$6,000 each, averaging \$3,600 per entrance.

References

Manual of Standards of Erosion and Sediment Control Measures, Association of Bay Area Governments, May 1995.

Stabilized Construction Entrance/Exit TC-1

National Management Measures to Control Nonpoint Source Pollution from Urban Areas, USEPA Agency, 2002.

Proposed Guidance Specifying Management Measures for Sources of Nonpoint Pollution in Coastal Waters, Work Group Working Paper, USEPA, April 1992.

Stormwater Quality Handbooks Construction Site Best Management Practices (BMPs) Manual, State of California Department of Transportation (Caltrans), November 2000.

Stormwater Management of the Puget Sound Basin, Technical Manual, Publication #91-75, Washington State Department of Ecology, February 1992.

Virginia Erosion and Sedimentation Control Handbook, Virginia Department of Conservation and Recreation, Division of Soil and Water Conservation, 1991.

Guidance Specifying Management Measures for Nonpoint Pollution in Coastal Waters, EPA 840-B-9-002, USEPA, Office of Water, Washington, DC, 1993.

Water Quality Management Plan for the Lake Tahoe Region, Volume II, Handbook of Management Practices, Tahoe Regional Planning Agency, November 1988.

Stabilized Construction Entrance/Exit TC-1

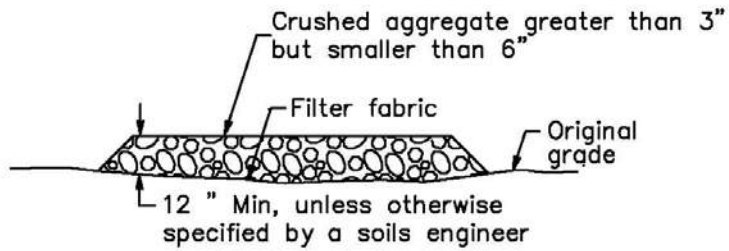

SECTION B-B
NTS

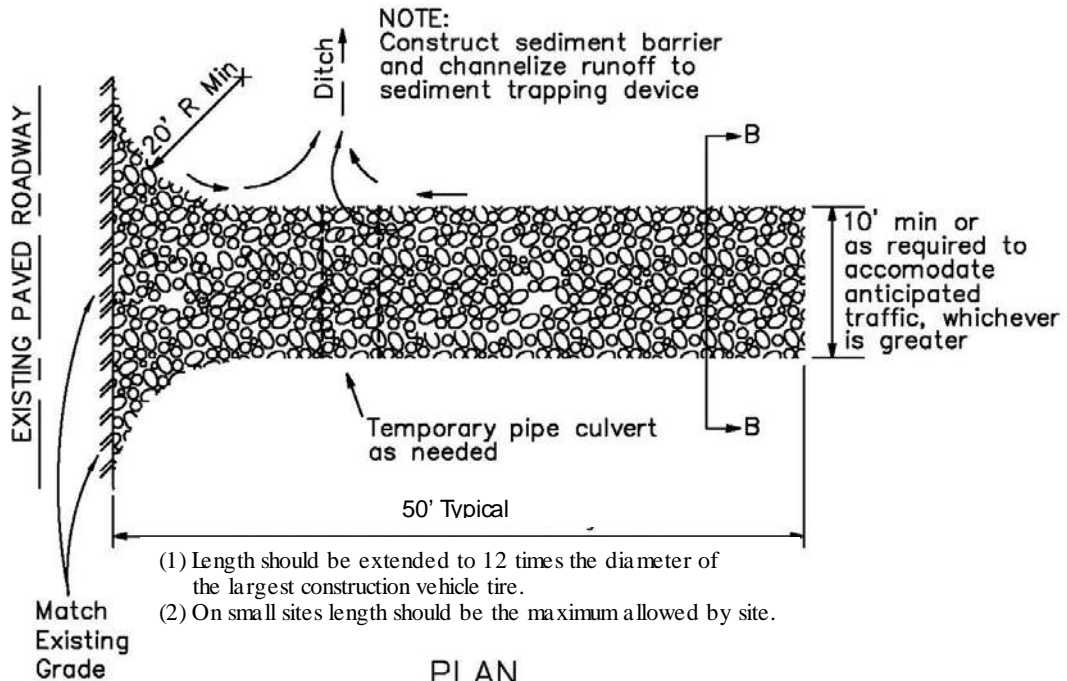

PLAN
NTS

Stabilized Construction Entrance/Exit TC-1

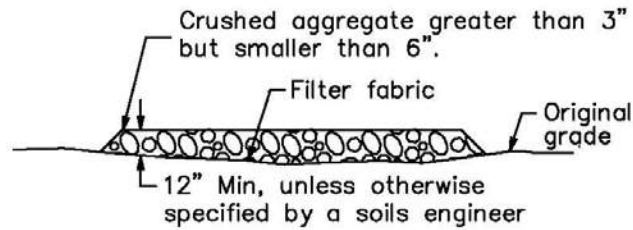

SECTION B-B
NTS

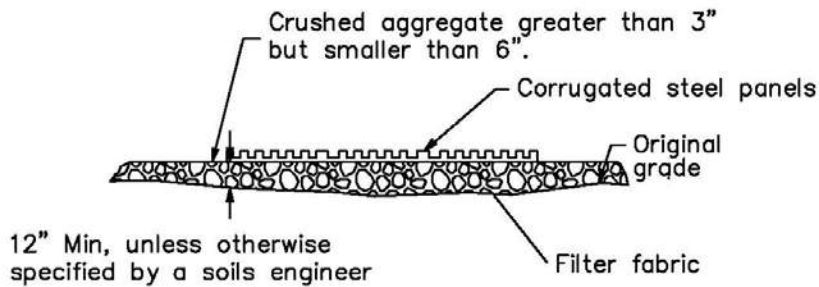

SECTION A-A
NOT TO SCALE

NOTE:
Construct sediment barrier and channelize runoff to sediment trapping device

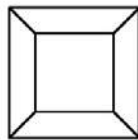

Sediment trapping device

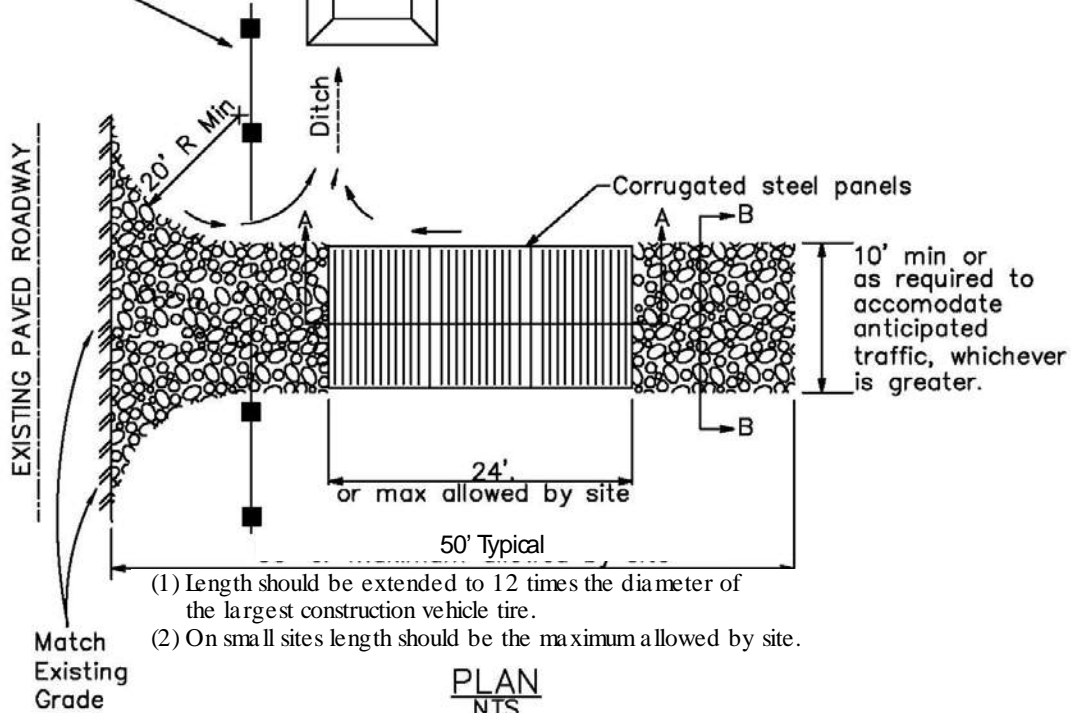

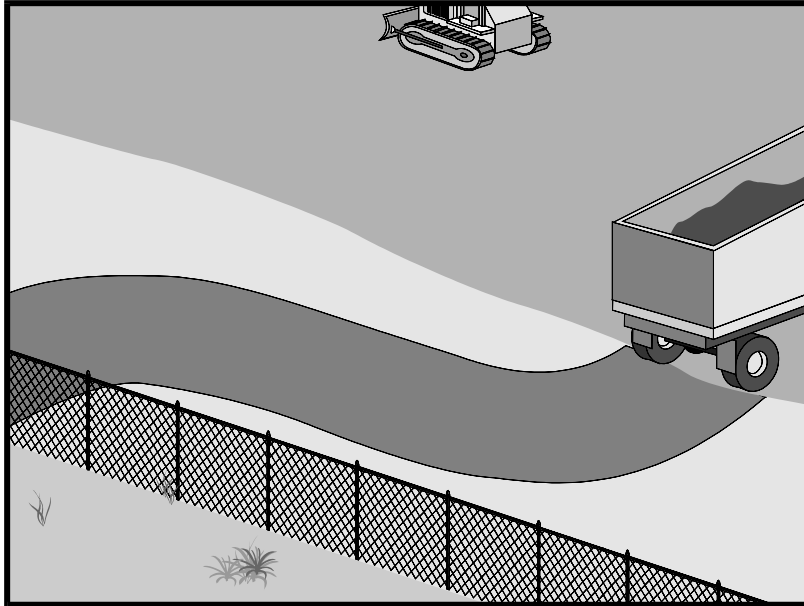

Categories

EC	Erosion Control	<input checked="" type="checkbox"/>
SE	Sediment Control	<input checked="" type="checkbox"/>
TC	Tracking Control	<input checked="" type="checkbox"/>
WE	Wind Erosion Control	
NS	Non-Stormwater Management Control	
WM	Waste Management and Materials Pollution Control	

Legend:

- Primary Objective
- Secondary Objective

Targeted Constituents

Sediment	<input checked="" type="checkbox"/>
Nutrients	
Trash	
Metals	
Bacteria	
Oil and Grease	
Organics	

Potential Alternatives

None

If User/Subscriber modifies this fact sheet in any way, the CASQA name/logo and footer below must be removed from each page and not appear on the modified version.

Description and Purpose

Access roads, subdivision roads, parking areas, and other onsite vehicle transportation routes should be stabilized immediately after grading, and frequently maintained to prevent erosion and control dust.

Suitable Applications

This BMP should be applied for the following conditions:

- Temporary Construction Traffic:
 - Phased construction projects and offsite road access
 - Construction during wet weather
- Construction roadways and detour roads:
 - Where mud tracking is a problem during wet weather
 - Where dust is a problem during dry weather
 - Adjacent to water bodies
 - Where poor soils are encountered

Limitations

- The roadway must be removed or paved when construction is complete.



- Certain chemical stabilization methods may cause stormwater or soil pollution and should not be used. See WE-1, Wind Erosion Control.
- Management of construction traffic is subject to air quality control measures. Contact the local air quality management agency.
- Materials will likely need to be removed prior to final project grading and stabilization.
- Use of this BMP may not be applicable to very short duration projects.

Implementation

General

Areas that are graded for construction vehicle transport and parking purposes are especially susceptible to erosion and dust. The exposed soil surface is continually disturbed, leaving no opportunity for vegetative stabilization. Such areas also tend to collect and transport runoff waters along their surfaces. During wet weather, they often become muddy quagmires that generate significant quantities of sediment that may pollute nearby streams or be transported offsite on the wheels of construction vehicles. Dirt roads can become so unstable during wet weather that they are virtually unusable.

Efficient construction road stabilization not only reduces onsite erosion but also can significantly speed onsite work, avoid instances of immobilized machinery and delivery vehicles, and generally improve site efficiency and working conditions during adverse weather

Installation/Application Criteria

Permanent roads and parking areas should be paved as soon as possible after grading. As an alternative where construction will be phased, the early application of gravel or chemical stabilization may solve potential erosion and stability problems. Temporary gravel roadway should be considered during the rainy season and on slopes greater than 5%.

Temporary roads should follow the contour of the natural terrain to the maximum extent possible. Slope should not exceed 15%. Roadways should be carefully graded to drain transversely. Provide drainage swales on each side of the roadway in the case of a crowned section or one side in the case of a super elevated section. Simple gravel berms without a trench can also be used.

Installed inlets should be protected to prevent sediment laden water from entering the storm sewer system (SE-10, Storm Drain Inlet Protection). In addition, the following criteria should be considered.

- Road should follow topographic contours to reduce erosion of the roadway.
- The roadway slope should not exceed 15%.
- Chemical stabilizers or water are usually required on gravel or dirt roads to prevent dust (WE-1, Wind Erosion Control).
- Properly grade roadway to prevent runoff from leaving the construction site.
- Design stabilized access to support heaviest vehicles and equipment that will use it.

- Stabilize roadway using aggregate, asphalt concrete, or concrete based on longevity, required performance, and site conditions. The use of cold mix asphalt or asphalt concrete (AC) grindings for stabilized construction roadway is not allowed.
- Coordinate materials with those used for stabilized construction entrance/exit points.
- If aggregate is selected, place crushed aggregate over geotextile fabric to at least 12 in. depth. A crushed aggregate greater than 3 in. but smaller than 6 in. should be used.

Inspection and Maintenance

- Inspect and verify that activity-based BMPs are in place prior to the commencement of associated activities. While activities associated with the BMP are under way, inspect BMPs in accordance with General Permit requirements for the associated project type and risk level. It is recommended that at a minimum, BMPs be inspected weekly, prior to forecasted rain events, daily during extended rain events, and after the conclusion of rain events.
- Keep all temporary roadway ditches clear.
- When no longer required, remove stabilized construction roadway and re-grade and repair slopes.
- Periodically apply additional aggregate on gravel roads.
- Active dirt construction roads are commonly watered three or more times per day during the dry season.

Costs

Gravel construction roads are moderately expensive, but cost is often balanced by reductions in construction delay. No additional costs for dust control on construction roads should be required above that needed to meet local air quality requirements.

References

Blueprint for a Clean Bay: Best Management Practices to Prevent Stormwater Pollution from Construction Related Activities; Santa Clara Valley Nonpoint Source Pollution Control Program, 1995.

Coastal Nonpoint Pollution Control Program; Program Development and Approval Guidance, Working Group, Working Paper; USEPA, April 1992.

Manual of Standards of Erosion and Sediment Control Measures, Association of Bay Area Governments, May 1995.

Stormwater Quality Handbooks Construction Site Best Management Practices (BMPs) Manual, State of California Department of Transportation (Caltrans), November 2000.

Stormwater Management for Construction Activities, Developing Pollution Prevention Plans and Best Management Practices, EPA 832-R-92005; USEPA, April 1992.

Stormwater Management of the Puget Sound Basin, Technical Manual, Publication #91-75, Washington State Department of Ecology, February 1992.

Virginia Erosion and Sedimentation Control Handbook, Virginia Department of Conservation and Recreation, Division of Soil and Water Conservation, 1991.

Water Quality Management Plan for the Lake Tahoe Region, Volume II, Handbook of Management Practices, Tahoe Regional Planning Agency, November 1988.

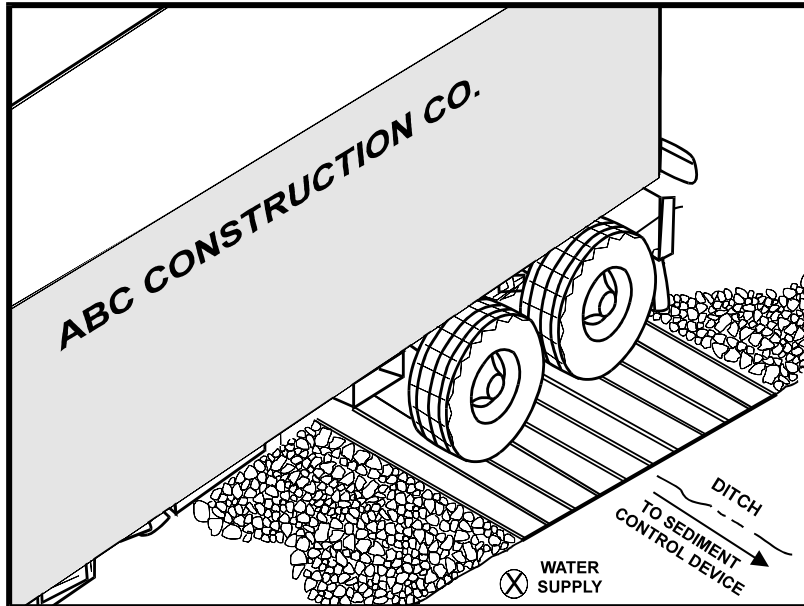

Description and Purpose

A tire wash is an area located at stabilized construction access points to remove sediment from tires and undercarriages and to prevent sediment from being transported onto public roadways.

Suitable Applications

Tire washes may be used on construction sites where dirt and mud tracking onto public roads by construction vehicles may occur.

Limitations

- The tire wash requires a supply of wash water.
- A turnout or doublewide exit is required to avoid having entering vehicles drive through the wash area.
- Do not use where wet tire trucks leaving the site leave the road dangerously slick.

Implementation

- Incorporate with a stabilized construction entrance/exit. See TC-1, Stabilized Construction Entrance/Exit.
- Construct on level ground when possible, on a pad of coarse aggregate greater than 3 in. but smaller than 6 in. A geotextile fabric should be placed below the aggregate.
- Wash rack should be designed and constructed/manufactured for anticipated traffic loads.

Categories

EC	Erosion Control	
SE	Sediment Control	<input checked="" type="checkbox"/>
TC	Tracking Control	<input checked="" type="checkbox"/>
WE	Wind Erosion Control	
NS	Non-Stormwater Management Control	
WM	Waste Management and Materials Pollution Control	

Legend:

- Primary Objective
- Secondary Objective

Targeted Constituents

Sediment	<input checked="" type="checkbox"/>
Nutrients	
Trash	
Metals	
Bacteria	
Oil and Grease	
Organics	

Potential Alternatives

TC-1 Stabilized Construction Entrance/Exit

If User/Subscriber modifies this fact sheet in any way, the CASQA name/logo and footer below must be removed from each page and not appear on the modified version.



- Provide a drainage ditch that will convey the runoff from the wash area to a sediment trapping device. The drainage ditch should be of sufficient grade, width, and depth to carry the wash runoff.
- Use hoses with automatic shutoff nozzles to prevent hoses from being left on.
- Require that all employees, subcontractors, and others that leave the site with mud caked tires and undercarriages to use the wash facility.
- Implement SC-7, Street Sweeping and Vacuuming, as needed.

Costs

Costs are low for installation of wash rack.

Inspection and Maintenance

- Inspect and verify that activity-based BMPs are in place prior to the commencement of associated activities. While activities associated with the BMP are under way, inspect BMPs in accordance with General Permit requirements for the associated project type and risk level. It is recommended that at a minimum, BMPs be inspected weekly, prior to forecasted rain events, daily during extended rain events, and after the conclusion of rain events.
- Inspect BMPs subject to non-stormwater discharge daily while non-stormwater discharges occur.
- Remove accumulated sediment in wash rack and/or sediment trap to maintain system performance.
- Inspect routinely for damage and repair as needed.

References

Blueprint for a Clean Bay: Best Management Practices to Prevent Stormwater Pollution from Construction Related Activities; Santa Clara Valley Nonpoint Source Pollution Control Program, 1995.

Coastal Nonpoint Pollution Control Program; Program Development and Approval Guidance, Working Group, Working Paper; USEPA, April 1992.

Manual of Standards of Erosion and Sediment Control Measures, Association of Bay Area Governments, May 1995.

Stormwater Quality Handbooks Construction Site Best Management Practices (BMPs) Manual, State of California Department of Transportation (Caltrans), November 2000.

Stormwater Management for Construction Activities, Developing Pollution Prevention Plans and Best Management Practices, EPA 832-R-92005; USEPA, April 1992.

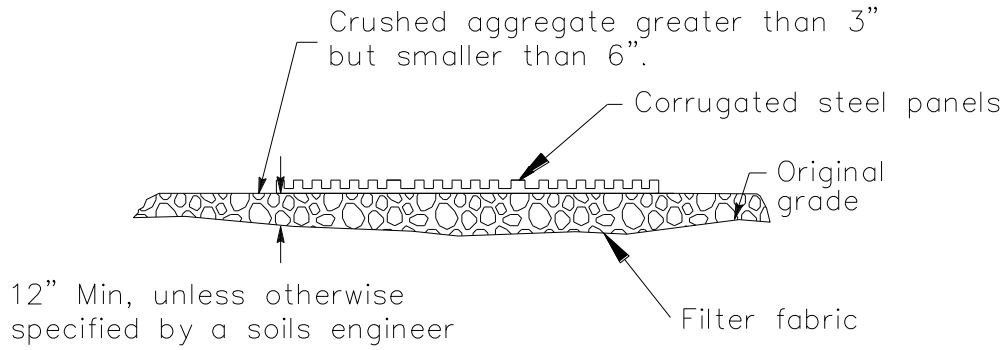

SECTION A-A
NOT TO SCALE

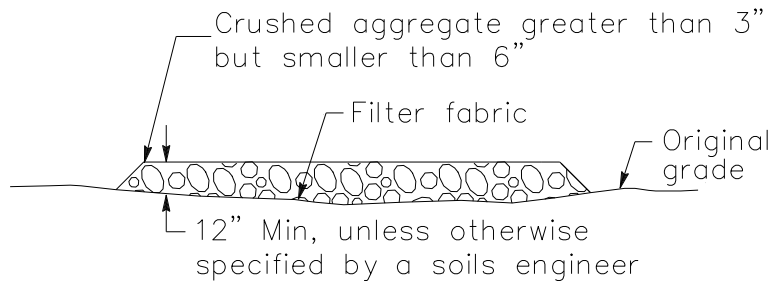

SECTION B-B
NTS

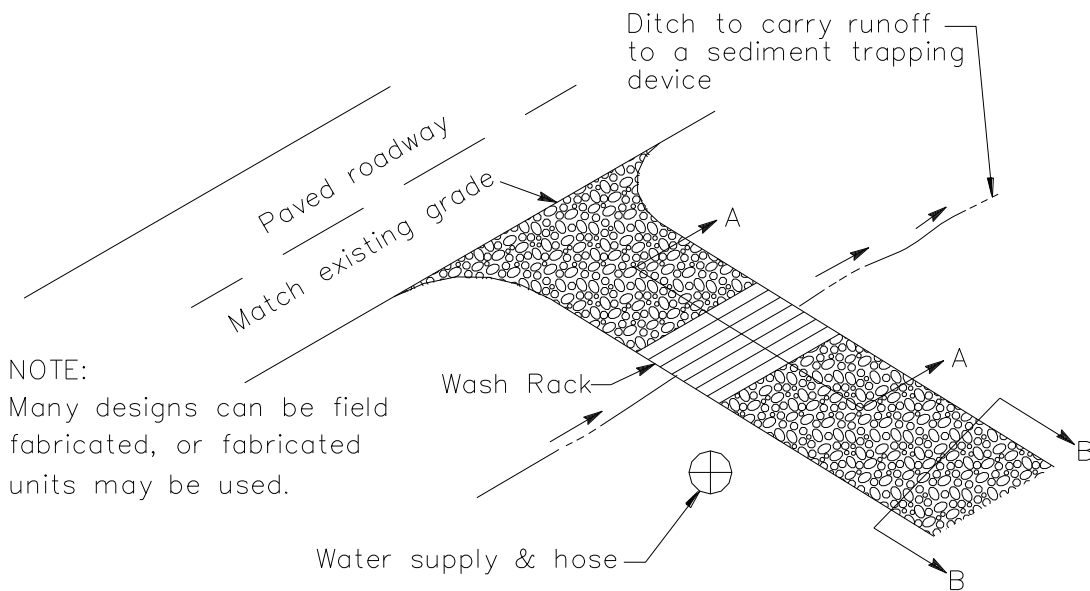

NOTE:
Many designs can be field fabricated, or fabricated units may be used.

TYPICAL TIRE WASH
NOT TO SCALE

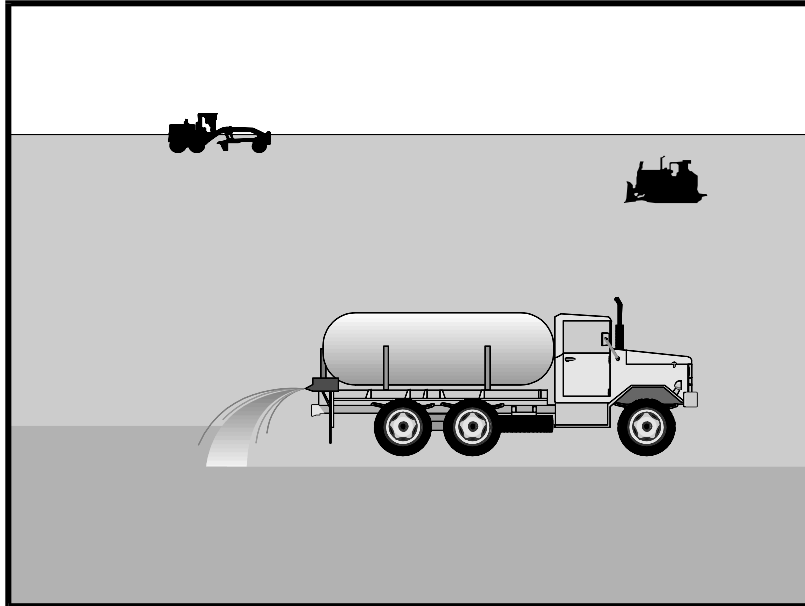

Description and Purpose

Wind erosion or dust control consists of applying water or other chemical dust suppressants as necessary to prevent or alleviate dust nuisance generated by construction activities. Covering small stockpiles or areas is an alternative to applying water or other dust palliatives.

California’s Mediterranean climate, with a short “wet” season and a typically long, hot “dry” season, allows the soils to thoroughly dry out. During the dry season, construction activities are at their peak, and disturbed and exposed areas are increasingly subject to wind erosion, sediment tracking and dust generated by construction equipment. Site conditions and climate can make dust control more of an erosion problem than water based erosion. Additionally, many local agencies, including Air Quality Management Districts, require dust control and/or dust control permits in order to comply with local nuisance laws, opacity laws (visibility impairment) and the requirements of the Clean Air Act. Wind erosion control is required to be implemented at all construction sites greater than 1 acre by the General Permit.

Suitable Applications

Most BMPs that provide protection against water-based erosion will also protect against wind-based erosion and dust control requirements required by other agencies will generally meet wind erosion control requirements for water quality protection. Wind erosion control BMPs are suitable during the following construction activities:

Categories

EC	Erosion Control	
SE	Sediment Control	<input checked="" type="checkbox"/>
TC	Tracking Control	
WE	Wind Erosion Control	<input checked="" type="checkbox"/>
NS	Non-Stormwater Management Control	
WM	Waste Management and Materials Pollution Control	

Legend:

- Primary Category
- Secondary Category

Targeted Constituents

Sediment	<input checked="" type="checkbox"/>
Nutrients	
Trash	
Metals	
Bacteria	
Oil and Grease	
Organics	

Potential Alternatives

EC-5 Soil Binders

If User/Subscriber modifies this fact sheet in any way, the CASQA name/logo and footer below must be removed from each page and not appear on the modified version.



- Construction vehicle traffic on unpaved roads
- Drilling and blasting activities
- Soils and debris storage piles
- Batch drop from front-end loaders
- Areas with unstabilized soil
- Final grading/site stabilization

Limitations

- Watering prevents dust only for a short period (generally less than a few hours) and should be applied daily (or more often) to be effective.
- Over watering may cause erosion and track-out.
- Oil or oil-treated subgrade should not be used for dust control because the oil may migrate into drainageways and/or seep into the soil.
- Chemical dust suppression agents may have potential environmental impacts. Selected chemical dust control agents should be environmentally benign.
- Effectiveness of controls depends on soil, temperature, humidity, wind velocity and traffic.
- Chemical dust suppression agents should not be used within 100 feet of wetlands or water bodies.
- Chemically treated subgrades may make the soil water repellent, interfering with long-term infiltration and the vegetation/re-vegetation of the site. Some chemical dust suppressants may be subject to freezing and may contain solvents and should be handled properly.
- In compacted areas, watering and other liquid dust control measures may wash sediment or other constituents into the drainage system.
- If the soil surface has minimal natural moisture, the affected area may need to be pre-wetted so that chemical dust control agents can uniformly penetrate the soil surface.

Implementation

Dust Control Practices

Dust control BMPs generally stabilize exposed surfaces and minimize activities that suspend or track dust particles. The following table presents dust control practices that can be applied to varying site conditions that could potentially cause dust. For heavily traveled and disturbed areas, wet suppression (watering), chemical dust suppression, gravel asphalt surfacing, temporary gravel construction entrances, equipment wash-out areas, and haul truck covers can be employed as dust control applications. Permanent or temporary vegetation and mulching can be employed for areas of occasional or no construction traffic. Preventive measures include minimizing surface areas to be disturbed, limiting onsite vehicle traffic to 15 mph or less, and controlling the number and activity of vehicles on a site at any given time.

Chemical dust suppressants include: mulch and fiber based dust palliatives (e.g. paper mulch with gypsum binder), salts and brines (e.g. calcium chloride, magnesium chloride), non-petroleum based organics (e.g. vegetable oil, lignosulfonate), petroleum based organics (e.g. asphalt emulsion, dust oils, petroleum resins), synthetic polymers (e.g. polyvinyl acetate, vinyls, acrylic), clay additives (e.g. bentonite, montmorillonite) and electrochemical products (e.g. enzymes, ionic products).

Site Condition	Dust Control Practices							
	Permanent Vegetation	Mulching	Wet Suppression (Watering)	Chemical Dust Suppression	Gravel or Asphalt	Temporary Gravel Construction Entrances/Equipment Wash Down	Synthetic Covers	Minimize Extent of Disturbed Area
Disturbed Areas not Subject to Traffic	X	X	X	X	X			X
Disturbed Areas Subject to Traffic			X	X	X	X		X
Material Stockpiles		X	X	X			X	X
Demolition			X			X	X	
Clearing/Excavation			X	X				X
Truck Traffic on Unpaved Roads			X	X	X	X	X	
Tracking					X	X		

Additional preventive measures include:

- Schedule construction activities to minimize exposed area (see EC-1, Scheduling).
- Quickly treat exposed soils using water, mulching, chemical dust suppressants, or stone/gravel layering.
- Identify and stabilize key access points prior to commencement of construction.
- Minimize the impact of dust by anticipating the direction of prevailing winds.
- Restrict construction traffic to stabilized roadways within the project site, as practicable.
- Water should be applied by means of pressure-type distributors or pipelines equipped with a spray system or hoses and nozzles that will ensure even distribution.
- All distribution equipment should be equipped with a positive means of shutoff.
- Unless water is applied by means of pipelines, at least one mobile unit should be available at all times to apply water or dust palliative to the project.
- If reclaimed waste water is used, the sources and discharge must meet California Department of Health Services water reclamation criteria and the Regional Water Quality

Control Board (RWQCB) requirements. Non-potable water should not be conveyed in tanks or drain pipes that will be used to convey potable water and there should be no connection between potable and non-potable supplies. Non-potable tanks, pipes, and other conveyances should be marked, "NON-POTABLE WATER - DO NOT DRINK."

- Pave or chemically stabilize access points where unpaved traffic surfaces adjoin paved roads.
- Provide covers for haul trucks transporting materials that contribute to dust.
- Provide for rapid clean up of sediments deposited on paved roads. Furnish stabilized construction road entrances and wheel wash areas.
- Stabilize inactive areas of construction sites using temporary vegetation or chemical stabilization methods.

For chemical stabilization, there are many products available for chemically stabilizing gravel roadways and stockpiles. If chemical stabilization is used, the chemicals should not create any adverse effects on stormwater, plant life, or groundwater and should meet all applicable regulatory requirements.

Costs

Installation costs for water and chemical dust suppression vary based on the method used and the length of effectiveness. Annual costs may be high since some of these measures are effective for only a few hours to a few days.

Inspection and Maintenance

- Inspect and verify that activity-based BMPs are in place prior to the commencement of associated activities.
- BMPs must be inspected in accordance with General Permit requirements for the associated project type and risk level. It is recommended that at a minimum, BMPs be inspected weekly, prior to forecasted rain events, daily during extended rain events, and after the conclusion of rain events.
- Check areas protected to ensure coverage.
- Most water-based dust control measures require frequent application, often daily or even multiple times per day. Obtain vendor or independent information on longevity of chemical dust suppressants.

References

Best Management Practices and Erosion Control Manual for Construction Sites, Flood Control District of Maricopa County, Arizona, September 1992.

California Air Pollution Control Laws, California Air Resources Board, updated annually.

Construction Manual, Chapter 4, Section 10, "Dust Control"; Section 17, "Watering"; and Section 18, "Dust Palliative", California Department of Transportation (Caltrans), July 2001.

Prospects for Attaining the State Ambient Air Quality Standards for Suspended Particulate Matter (PM10), Visibility Reducing Particles, Sulfates, Lead, and Hydrogen Sulfide, California Air Resources Board, April 1991.

Stormwater Quality Handbooks Construction Site Best Management Practices (BMPs) Manual, State of California Department of Transportation (Caltrans), March 2003.

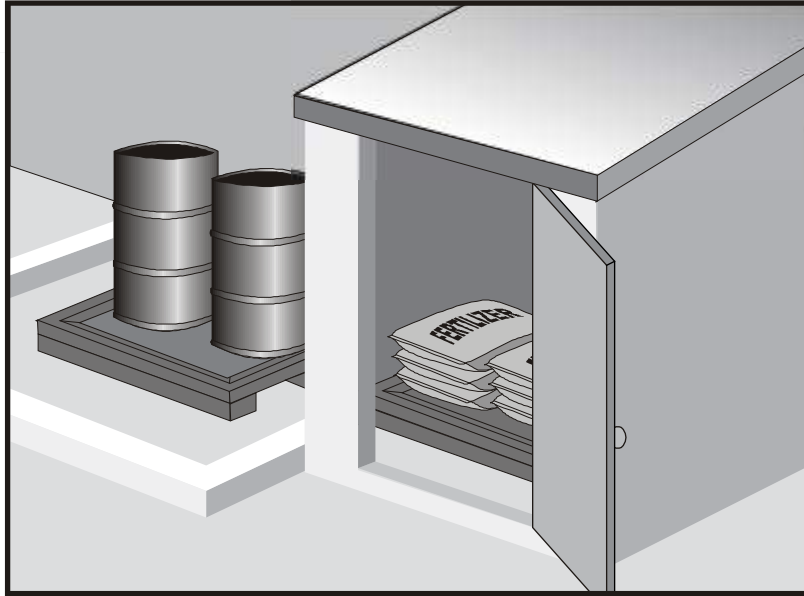

Categories

EC	Erosion Control	
SE	Sediment Control	
TC	Tracking Control	
WE	Wind Erosion Control	
NS	Non-Stormwater Management Control	
WM	Waste Management and Materials Pollution Control	<input checked="" type="checkbox"/>

Legend:

- Primary Category
- Secondary Category

Description and Purpose

Prevent, reduce, or eliminate the discharge of pollutants from material delivery and storage to the stormwater system or watercourses by minimizing the storage of hazardous materials onsite, storing materials in watertight containers and/or a completely enclosed designated area, installing secondary containment, conducting regular inspections, and training employees and subcontractors.

This best management practice covers only material delivery and storage. For other information on materials, see WM-2, Material Use, or WM-4, Spill Prevention and Control. For information on wastes, see the waste management BMPs in this section.

Suitable Applications

These procedures are suitable for use at all construction sites with delivery and storage of the following materials:

- Soil stabilizers and binders
- Pesticides and herbicides
- Fertilizers
- Detergents
- Plaster
- Petroleum products such as fuel, oil, and grease

Targeted Constituents

Sediment	<input checked="" type="checkbox"/>
Nutrients	<input checked="" type="checkbox"/>
Trash	<input checked="" type="checkbox"/>
Metals	<input checked="" type="checkbox"/>
Bacteria	
Oil and Grease	<input checked="" type="checkbox"/>
Organics	<input checked="" type="checkbox"/>

Potential Alternatives

None

If User/Subscriber modifies this fact sheet in any way, the CASQA name/logo and footer below must be removed from each page and not appear on the modified version.



- Asphalt and concrete components
- Hazardous chemicals such as acids, lime, glues, adhesives, paints, solvents, and curing compounds
- Concrete compounds
- Other materials that may be detrimental if released to the environment

Limitations

- Space limitation may preclude indoor storage.
- Storage sheds often must meet building and fire code requirements.

Implementation

The following steps should be taken to minimize risk:

- Chemicals must be stored in water tight containers with appropriate secondary containment or in a storage shed.
- When a material storage area is located on bare soil, the area should be lined and bermed.
- Use containment pallets or other practical and available solutions, such as storing materials within newly constructed buildings or garages, to meet material storage requirements.
- Stack erodible landscape material on pallets and cover when not in use.
- Contain all fertilizers and other landscape materials when not in use.
- Temporary storage areas should be located away from vehicular traffic.
- Material Safety Data Sheets (MSDS) should be available on-site for all materials stored that have the potential to effect water quality.
- Construction site areas should be designated for material delivery and storage.
- Material delivery and storage areas should be located away from waterways, if possible.
 - Avoid transport near drainage paths or waterways.
 - Surround with earth berms or other appropriate containment BMP. See EC-9, Earth Dikes and Drainage Swales.
 - Place in an area that will be paved.
- Storage of reactive, ignitable, or flammable liquids must comply with the fire codes of your area. Contact the local Fire Marshal to review site materials, quantities, and proposed storage area to determine specific requirements. See the Flammable and Combustible Liquid Code, NFPA30.
- An up to date inventory of materials delivered and stored onsite should be kept.

- Hazardous materials storage onsite should be minimized.
- Hazardous materials should be handled as infrequently as possible.
- Keep ample spill cleanup supplies appropriate for the materials being stored. Ensure that cleanup supplies are in a conspicuous, labeled area.
- Employees and subcontractors should be trained on the proper material delivery and storage practices.
- Employees trained in emergency spill cleanup procedures must be present when dangerous materials or liquid chemicals are unloaded.
- If significant residual materials remain on the ground after construction is complete, properly remove and dispose of materials and any contaminated soil. See WM-7, Contaminated Soil Management. If the area is to be paved, pave as soon as materials are removed to stabilize the soil.

Material Storage Areas and Practices

- Liquids, petroleum products, and substances listed in 40 CFR Parts 110, 117, or 302 should be stored in approved containers and drums and should not be overfilled. Containers and drums should be placed in temporary containment facilities for storage.
- A temporary containment facility should provide for a spill containment volume able to contain precipitation from a 25 year storm event, plus the greater of 10% of the aggregate volume of all containers or 100% of the capacity of the largest container within its boundary, whichever is greater.
- A temporary containment facility should be impervious to the materials stored therein for a minimum contact time of 72 hours.
- A temporary containment facility should be maintained free of accumulated rainwater and spills. In the event of spills or leaks, accumulated rainwater and spills should be collected and placed into drums. These liquids should be handled as a hazardous waste unless testing determines them to be non-hazardous. All collected liquids or non-hazardous liquids should be sent to an approved disposal site.
- Sufficient separation should be provided between stored containers to allow for spill cleanup and emergency response access.
- Incompatible materials, such as chlorine and ammonia, should not be stored in the same temporary containment facility.
- Materials should be covered prior to, and during rain events.
- Materials should be stored in their original containers and the original product labels should be maintained in place in a legible condition. Damaged or otherwise illegible labels should be replaced immediately.

- Bagged and boxed materials should be stored on pallets and should not be allowed to accumulate on the ground. To provide protection from wind and rain throughout the rainy season, bagged and boxed materials should be covered during non-working days and prior to and during rain events.
- Stockpiles should be protected in accordance with WM-3, Stockpile Management.
- Materials should be stored indoors within existing structures or completely enclosed storage sheds when available.
- Proper storage instructions should be posted at all times in an open and conspicuous location.
- An ample supply of appropriate spill clean up material should be kept near storage areas.
- Also see WM-6, Hazardous Waste Management, for storing of hazardous wastes.

Material Delivery Practices

- Keep an accurate, up-to-date inventory of material delivered and stored onsite.
- Arrange for employees trained in emergency spill cleanup procedures to be present when dangerous materials or liquid chemicals are unloaded.

Spill Cleanup

- Contain and clean up any spill immediately.
- Properly remove and dispose of any hazardous materials or contaminated soil if significant residual materials remain on the ground after construction is complete. See WM-7, Contaminated Soil Management.
- See WM-4, Spill Prevention and Control, for spills of chemicals and/or hazardous materials.
- If spills or leaks of materials occur that are not contained and could discharge to surface waters, non-visible sampling of site discharge may be required. Refer to the General Permit or to your project specific Construction Site Monitoring Plan to determine if and where sampling is required.

Cost

- The largest cost of implementation may be in the construction of a materials storage area that is covered and provides secondary containment.

Inspection and Maintenance

- BMPs must be inspected in accordance with General Permit requirements for the associated project type and risk level. It is recommended that at a minimum, BMPs be inspected weekly, prior to forecasted rain events, daily during extended rain events, and after the conclusion of rain events.
- Keep storage areas clean and well organized, including a current list of all materials onsite.
- Inspect labels on containers for legibility and accuracy.

- Repair or replace perimeter controls, containment structures, covers, and liners as needed to maintain proper function.

References

Blueprint for a Clean Bay: Best Management Practices to Prevent Stormwater Pollution from Construction Related Activities; Santa Clara Valley Nonpoint Source Pollution Control Program, 1995.

Coastal Nonpoint Pollution Control Program: Program Development and Approval Guidance, Working Group Working Paper; USEPA, April 1992.

Stormwater Quality Handbooks - Construction Site Best Management Practices (BMPs) Manual, State of California Department of Transportation (Caltrans), March 2003.

Stormwater Management for Construction Activities; Developing Pollution Prevention Plans and Best Management Practice, EPA 832-R-92005; USEPA, April 1992.

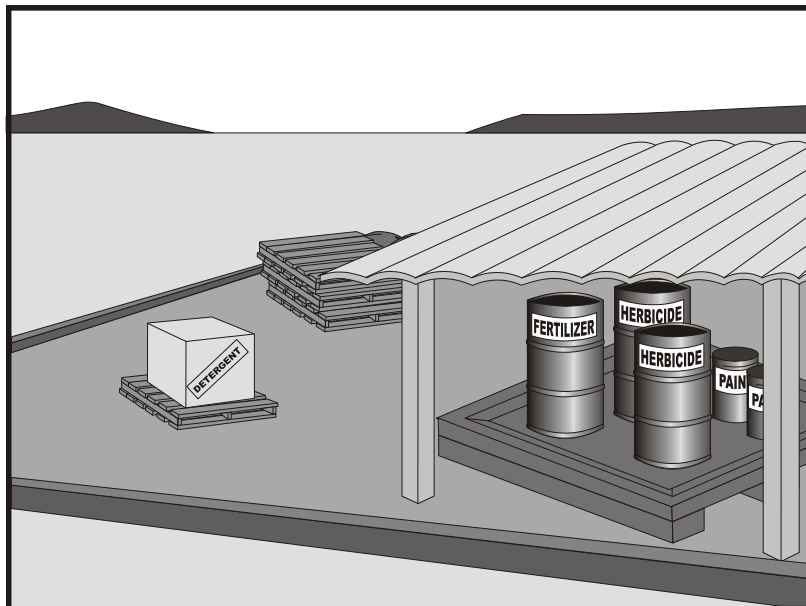

Categories

EC	Erosion Control	
SE	Sediment Control	
TC	Tracking Control	
WE	Wind Erosion Control	
NS	Non-Stormwater Management Control	
WM	Waste Management and Materials Pollution Control	<input checked="" type="checkbox"/>

Legend:

- Primary Category
- Secondary Category

Targeted Constituents

Sediment	<input checked="" type="checkbox"/>
Nutrients	<input checked="" type="checkbox"/>
Trash	<input checked="" type="checkbox"/>
Metals	<input checked="" type="checkbox"/>
Bacteria	
Oil and Grease	<input checked="" type="checkbox"/>
Organics	<input checked="" type="checkbox"/>

Potential Alternatives

None

Description and Purpose

Prevent or reduce the discharge of pollutants to the storm drain system or watercourses from material use by using alternative products, minimizing hazardous material use onsite, and training employees and subcontractors.

Suitable Applications

This BMP is suitable for use at all construction projects. These procedures apply when the following materials are used or prepared onsite:

- Pesticides and herbicides
- Fertilizers
- Detergents
- Petroleum products such as fuel, oil, and grease
- Asphalt and other concrete components
- Other hazardous chemicals such as acids, lime, glues, adhesives, paints, solvents, and curing compounds
- Other materials that may be detrimental if released to the environment

If User/Subscriber modifies this fact sheet in any way, the CASQA name/logo and footer below must be removed from each page and not appear on the modified version.



Limitations

Safer alternative building and construction products may not be available or suitable in every instance.

Implementation

The following steps should be taken to minimize risk:

- Minimize use of hazardous materials onsite.
- Follow manufacturer instructions regarding uses, protective equipment, ventilation, flammability, and mixing of chemicals.
- Train personnel who use pesticides. The California Department of Pesticide Regulation and county agricultural commissioners license pesticide dealers, certify pesticide applicators, and conduct onsite inspections.
- The preferred method of termiticide application is soil injection near the existing or proposed structure foundation/slab; however, if not feasible, soil drench application of termiticides should follow EPA label guidelines and the following recommendations (most of which are applicable to most pesticide applications):
 - Do not treat soil that is water-saturated or frozen.
 - Application shall not commence within 24-hours of a predicted precipitation event with a 40% or greater probability. Weather tracking must be performed on a daily basis prior to termiticide application and during the period of termiticide application.
 - Do not allow treatment chemicals to runoff from the target area. Apply proper quantity to prevent excess runoff. Provide containment for and divert stormwater from application areas using berms or diversion ditches during application.
 - Dry season: Do not apply within 10 feet of storm drains. Do not apply within 25 feet of aquatic habitats (such as, but not limited to, lakes; reservoirs; rivers; permanent streams; marshes or ponds; estuaries; and commercial fish farm ponds).
 - Wet season: Do not apply within 50 feet of storm drains or aquatic habitats (such as, but not limited to, lakes; reservoirs; rivers; permanent streams; marshes or ponds; estuaries; and commercial fish farm ponds) unless a vegetative buffer is present (if so, refer to dry season requirements).
 - Do not make on-grade applications when sustained wind speeds are above 10 mph (at application site) at nozzle end height.
 - Cover treatment site prior to a rain event in order to prevent run-off of the pesticide into non-target areas. The treated area should be limited to a size that can be backfilled and/or covered by the end of the work shift. Backfilling or covering of the treated area shall be done by the end of the same work shift in which the application is made.
 - The applicator must either cover the soil him/herself or provide written notification of the above requirement to the contractor on site and to the person commissioning the

application (if different than the contractor). If notice is provided to the contractor or the person commissioning the application, then they are responsible under the Federal Insecticide Fungicide, and Rodenticide Act (FIFRA) to ensure that: 1) if the concrete slab cannot be poured over the treated soil within 24 hours of application, the treated soil is covered with a waterproof covering (such as polyethylene sheeting), and 2) the treated soil is covered if precipitation is predicted to occur before the concrete slab is scheduled to be poured.

- Do not over-apply fertilizers, herbicides, and pesticides. Prepare only the amount needed. Follow the recommended usage instructions. Over-application is expensive and environmentally harmful. Unless on steep slopes, till fertilizers into the soil rather than hydraulic application. Apply surface dressings in several smaller applications, as opposed to one large application, to allow time for infiltration and to avoid excess material being carried offsite by runoff. Do not apply these chemicals before predicted rainfall.
- Train employees and subcontractors in proper material use.
- Supply Material Safety Data Sheets (MSDS) for all materials.
- Dispose of latex paint and paint cans, used brushes, rags, absorbent materials, and drop cloths, when thoroughly dry and are no longer hazardous, with other construction debris.
- Do not remove the original product label; it contains important safety and disposal information. Use the entire product before disposing of the container.
- Mix paint indoors or in a containment area. Never clean paintbrushes or rinse paint containers into a street, gutter, storm drain, or watercourse. Dispose of any paint thinners, residue, and sludge(s) that cannot be recycled, as hazardous waste.
- For water-based paint, clean brushes to the extent practicable, and rinse to a drain leading to a sanitary sewer where permitted, or contain for proper disposal off site. For oil-based paints, clean brushes to the extent practicable, and filter and reuse thinners and solvents.
- Use recycled and less hazardous products when practical. Recycle residual paints, solvents, non-treated lumber, and other materials.
- Use materials only where and when needed to complete the construction activity. Use safer alternative materials as much as possible. Reduce or eliminate use of hazardous materials onsite when practical.
- Document the location, time, chemicals applied, and applicator's name and qualifications.
- Keep an ample supply of spill clean up material near use areas. Train employees in spill clean up procedures.
- Avoid exposing applied materials to rainfall and runoff unless sufficient time has been allowed for them to dry.
- Discontinue use of erodible landscape material within 2 days prior to a forecasted rain event and materials should be covered and/or bermed.

- Provide containment for material use areas such as masons' areas or paint mixing/preparation areas to prevent materials/pollutants from entering stormwater.

Costs

All of the above are low cost measures.

Inspection and Maintenance

- Inspect and verify that activity-based BMPs are in place prior to the commencement of associated activities.
- BMPs must be inspected in accordance with General Permit requirements for the associated project type and risk level. It is recommended that at a minimum, BMPs be inspected weekly, prior to forecasted rain events, daily during extended rain events, and after the conclusion of rain events.
- Ensure employees and subcontractors throughout the job are using appropriate practices.

References

Blueprint for a Clean Bay: Best Management Practices to Prevent Stormwater Pollution from Construction Related Activities; Santa Clara Valley Nonpoint Source Pollution Control Program, 1995.

Coastal Nonpoint Pollution Control Program: Program Development and Approval Guidance, Working Group Working Paper; USEPA, April 1992.

Comments on Risk Assessments Risk Reduction Options for Cypermethrin: Docket No. OPP-2005-0293; California Stormwater Quality Association (CASQA) letter to USEPA, 2006. Environmental Hazard and General Labeling for Pyrethroid Non-Agricultural Outdoor Products, EPA-HQ-OPP-2008-0331-0021; USEPA, 2008.

Stormwater Quality Handbooks - Construction Site Best Management Practices (BMPs) Manual, State of California Department of Transportation (Caltrans), March 2003.

Stormwater Management for Construction Activities; Developing Pollution Prevention Plans and Best Management Practice, EPA 832-R-92005; USEPA, April 1992.

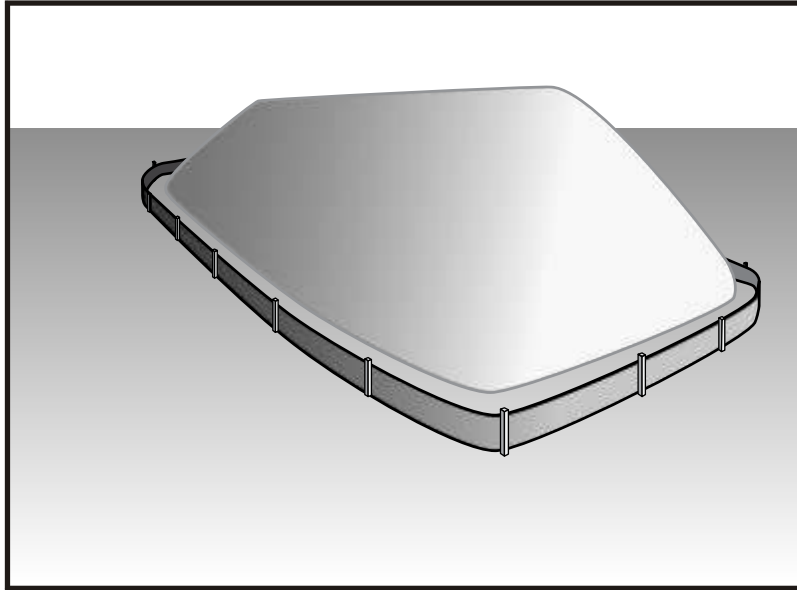

Description and Purpose

Stockpile management procedures and practices are designed to reduce or eliminate air and stormwater pollution from stockpiles of soil, soil amendments, sand, paving materials such as portland cement concrete (PCC) rubble, asphalt concrete (AC), asphalt concrete rubble, aggregate base, aggregate sub base or pre-mixed aggregate, asphalt minder (so called “cold mix” asphalt), and pressure treated wood.

Suitable Applications

Implement in all projects that stockpile soil and other loose materials.

Limitations

- Plastic sheeting as a stockpile protection is temporary and hard to manage in windy conditions. Where plastic is used, consider use of plastic tarps with nylon reinforcement which may be more durable than standard sheeting.
- Plastic sheeting can increase runoff volume due to lack of infiltration and potentially cause perimeter control failure.
- Plastic sheeting breaks down faster in sunlight.
- The use of Plastic materials and photodegradable plastics should be avoided.

Implementation

Protection of stockpiles is a year-round requirement. To properly manage stockpiles:

Categories

EC	Erosion Control	
SE	Sediment Control	<input checked="" type="checkbox"/>
TC	Tracking Control	
WE	Wind Erosion Control	
NS	Non-Stormwater Management Control	<input checked="" type="checkbox"/>
WM	Waste Management and Materials Pollution Control	<input checked="" type="checkbox"/>

Legend:

- Primary Category
- Secondary Category

Targeted Constituents

Sediment	<input checked="" type="checkbox"/>
Nutrients	<input checked="" type="checkbox"/>
Trash	<input checked="" type="checkbox"/>
Metals	<input checked="" type="checkbox"/>
Bacteria	
Oil and Grease	<input checked="" type="checkbox"/>
Organics	<input checked="" type="checkbox"/>

Potential Alternatives

None

If User/Subscriber modifies this fact sheet in any way, the CASQA name/logo and footer below must be removed from each page and not appear on the modified version.



- On larger sites, a minimum of 50 ft separation from concentrated flows of stormwater, drainage courses, and inlets is recommended.
- After 14 days of inactivity, a stockpile is non-active and requires further protection described below. All stockpiles are required to be protected as non-active stockpiles immediately if they are not scheduled to be used within 14 days.
- Protect all stockpiles from stormwater runoff using temporary perimeter sediment barriers such as compost berms (SE-13), temporary silt dikes (SE-12), fiber rolls (SE-5), silt fences (SE-1), sandbags (SE-8), gravel bags (SE-6), or biofilter bags (SE-14). Refer to the individual fact sheet for each of these controls for installation information.
- Implement wind erosion control practices as appropriate on all stockpiled material. For specific information, see WE-1, Wind Erosion Control.
- Manage stockpiles of contaminated soil in accordance with WM-7, Contaminated Soil Management.
- Place bagged materials on pallets and under cover.
- Ensure that stockpile coverings are installed securely to protect from wind and rain.
- Some plastic covers withstand weather and sunlight better than others. Select cover materials or methods based on anticipated duration of use.

Protection of Non-Active Stockpiles

A stockpile is considered non-active if it either is not used for 14 days or if it is scheduled not to be used for 14 days or more. Stockpiles need to be protected immediately if they are not scheduled to be used within 14 days. Non-active stockpiles of the identified materials should be protected as follows:

Soil stockpiles

- Soil stockpiles should be covered or protected with soil stabilization measures and a temporary perimeter sediment barrier at all times.
- Temporary vegetation should be considered for topsoil piles that will be stockpiled for extended periods.

Stockpiles of Portland cement concrete rubble, asphalt concrete, asphalt concrete rubble, aggregate base, or aggregate sub base

- Stockpiles should be covered and protected with a temporary perimeter sediment barrier at all times.

Stockpiles of “cold mix”

- Cold mix stockpiles should be placed on and covered with plastic sheeting or comparable material at all times and surrounded by a berm.

Stockpiles of fly ash, stucco, hydrated lime

- Stockpiles of materials that may raise the pH of runoff (i.e., basic materials) should be covered with plastic and surrounded by a berm.

Stockpiles/Storage of wood (Pressure treated with chromated copper arsenate or ammoniacal copper zinc arsenate)

- Treated wood should be covered with plastic sheeting or comparable material at all times and surrounded by a berm.

Protection of Active Stockpiles

A stockpile is active when it is being used or is scheduled to be used within 14 days of the previous use. Active stockpiles of the identified materials should be protected as follows:

- All stockpiles should be covered and protected with a temporary linear sediment barrier prior to the onset of precipitation.
- Stockpiles of “cold mix” and treated wood, and basic materials should be placed on and covered with plastic sheeting or comparable material and surrounded by a berm prior to the onset of precipitation.
- The downstream perimeter of an active stockpile should be protected with a linear sediment barrier or berm and runoff should be diverted around or away from the stockpile on the upstream perimeter.

Costs

For cost information associated with stockpile protection refer to the individual erosion or sediment control BMP fact sheet considered for implementation (For example, refer to SE-1 Silt Fence for installation of silt fence around the perimeter of a stockpile.)

Inspection and Maintenance

- Stockpiles must be inspected in accordance with General Permit requirements for the associated project type and risk level. It is recommended that at a minimum, BMPs be inspected weekly, prior to forecasted rain events, daily during extended rain events, and after the conclusion of rain events.
- It may be necessary to inspect stockpiles covered with plastic sheeting more frequently during certain conditions (for example, high winds or extreme heat).
- Repair and/or replace perimeter controls and covers as needed to keep them functioning properly.
- Sediment shall be removed when it reaches one-third of the barrier height.

References

Stormwater Quality Handbooks - Construction Site Best Management Practices (BMPs) Manual, State of California Department of Transportation (Caltrans), March 2003.

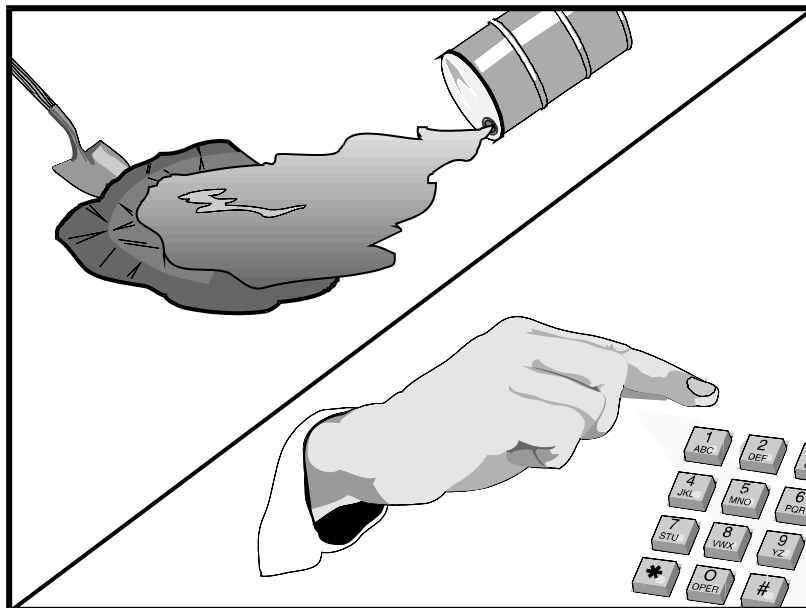

Description and Purpose

Prevent or reduce the discharge of pollutants to drainage systems or watercourses from leaks and spills by reducing the chance for spills, stopping the source of spills, containing and cleaning up spills, properly disposing of spill materials, and training employees.

This best management practice covers only spill prevention and control. However, WM-1, Materials Delivery and Storage, and WM-2, Material Use, also contain useful information, particularly on spill prevention. For information on wastes, see the waste management BMPs in this section.

Suitable Applications

This BMP is suitable for all construction projects. Spill control procedures are implemented anytime chemicals or hazardous substances are stored on the construction site, including the following materials:

- Soil stabilizers/binders
- Dust palliatives
- Herbicides
- Growth inhibitors
- Fertilizers
- Deicing/anti-icing chemicals

Categories

EC	Erosion Control	
SE	Sediment Control	
TC	Tracking Control	
WE	Wind Erosion Control	
NS	Non-Stormwater Management Control	
WM	Waste Management and Materials Pollution Control	<input checked="" type="checkbox"/>

Legend:

- Primary Objective
- Secondary Objective

Targeted Constituents

Sediment	<input checked="" type="checkbox"/>
Nutrients	<input checked="" type="checkbox"/>
Trash	<input checked="" type="checkbox"/>
Metals	<input checked="" type="checkbox"/>
Bacteria	
Oil and Grease	<input checked="" type="checkbox"/>
Organics	<input checked="" type="checkbox"/>

Potential Alternatives

None

If User/Subscriber modifies this fact sheet in any way, the CASQA name/logo and footer below must be removed from each page and not appear on the modified version.



- Fuels
- Lubricants
- Other petroleum distillates

Limitations

- In some cases it may be necessary to use a private spill cleanup company.
- This BMP applies to spills caused by the contractor and subcontractors.
- Procedures and practices presented in this BMP are general. Contractor should identify appropriate practices for the specific materials used or stored onsite

Implementation

The following steps will help reduce the stormwater impacts of leaks and spills:

Education

- Be aware that different materials pollute in different amounts. Make sure that each employee knows what a “significant spill” is for each material they use, and what is the appropriate response for “significant” and “insignificant” spills.
- Educate employees and subcontractors on potential dangers to humans and the environment from spills and leaks.
- Hold regular meetings to discuss and reinforce appropriate disposal procedures (incorporate into regular safety meetings).
- Establish a continuing education program to indoctrinate new employees.
- Have contractor’s superintendent or representative oversee and enforce proper spill prevention and control measures.

General Measures

- To the extent that the work can be accomplished safely, spills of oil, petroleum products, substances listed under 40 CFR parts 110,117, and 302, and sanitary and septic wastes should be contained and cleaned up immediately.
- Store hazardous materials and wastes in covered containers and protect from vandalism.
- Place a stockpile of spill cleanup materials where it will be readily accessible.
- Train employees in spill prevention and cleanup.
- Designate responsible individuals to oversee and enforce control measures.
- Spills should be covered and protected from stormwater runoff during rainfall to the extent that it doesn’t compromise clean up activities.
- Do not bury or wash spills with water.

- Store and dispose of used clean up materials, contaminated materials, and recovered spill material that is no longer suitable for the intended purpose in conformance with the provisions in applicable BMPs.
- Do not allow water used for cleaning and decontamination to enter storm drains or watercourses. Collect and dispose of contaminated water in accordance with WM-10, Liquid Waste Management.
- Contain water overflow or minor water spillage and do not allow it to discharge into drainage facilities or watercourses.
- Place proper storage, cleanup, and spill reporting instructions for hazardous materials stored or used on the project site in an open, conspicuous, and accessible location.
- Keep waste storage areas clean, well organized, and equipped with ample cleanup supplies as appropriate for the materials being stored. Perimeter controls, containment structures, covers, and liners should be repaired or replaced as needed to maintain proper function.

Cleanup

- Clean up leaks and spills immediately.
- Use a rag for small spills on paved surfaces, a damp mop for general cleanup, and absorbent material for larger spills. If the spilled material is hazardous, then the used cleanup materials are also hazardous and must be sent to either a certified laundry (rags) or disposed of as hazardous waste.
- Never hose down or bury dry material spills. Clean up as much of the material as possible and dispose of properly. See the waste management BMPs in this section for specific information.

Minor Spills

- Minor spills typically involve small quantities of oil, gasoline, paint, etc. which can be controlled by the first responder at the discovery of the spill.
- Use absorbent materials on small spills rather than hosing down or burying the spill.
- Absorbent materials should be promptly removed and disposed of properly.
- Follow the practice below for a minor spill:
 - Contain the spread of the spill.
 - Recover spilled materials.
 - Clean the contaminated area and properly dispose of contaminated materials.

Semi-Significant Spills

- Semi-significant spills still can be controlled by the first responder along with the aid of other personnel such as laborers and the foreman, etc. This response may require the cessation of all other activities.

- Spills should be cleaned up immediately:
 - Contain spread of the spill.
 - Notify the project foreman immediately.
 - If the spill occurs on paved or impermeable surfaces, clean up using "dry" methods (absorbent materials, cat litter and/or rags). Contain the spill by encircling with absorbent materials and do not let the spill spread widely.
 - If the spill occurs in dirt areas, immediately contain the spill by constructing an earthen dike. Dig up and properly dispose of contaminated soil.
 - If the spill occurs during rain, cover spill with tarps or other material to prevent contaminating runoff.

Significant/Hazardous Spills

- For significant or hazardous spills that cannot be controlled by personnel in the immediate vicinity, the following steps should be taken:
 - Notify the local emergency response by dialing 911. In addition to 911, the contractor will notify the proper county officials. It is the contractor's responsibility to have all emergency phone numbers at the construction site.
 - Notify the Governor's Office of Emergency Services Warning Center, (916) 845-8911.
 - For spills of federal reportable quantities, in conformance with the requirements in 40 CFR parts 110,119, and 302, the contractor should notify the National Response Center at (800) 424-8802.
 - Notification should first be made by telephone and followed up with a written report.
 - The services of a spills contractor or a Haz-Mat team should be obtained immediately. Construction personnel should not attempt to clean up until the appropriate and qualified staffs have arrived at the job site.
 - Other agencies which may need to be consulted include, but are not limited to, the Fire Department, the Public Works Department, the Coast Guard, the Highway Patrol, the City/County Police Department, Department of Toxic Substances, California Division of Oil and Gas, Cal/OSHA, etc.

Reporting

- Report significant spills to local agencies, such as the Fire Department; they can assist in cleanup.
- Federal regulations require that any significant oil spill into a water body or onto an adjoining shoreline be reported to the National Response Center (NRC) at 800-424-8802 (24 hours).

Use the following measures related to specific activities:

Vehicle and Equipment Maintenance

- If maintenance must occur onsite, use a designated area and a secondary containment, located away from drainage courses, to prevent the runoff of stormwater and the runoff of spills.
- Regularly inspect onsite vehicles and equipment for leaks and repair immediately
- Check incoming vehicles and equipment (including delivery trucks, and employee and subcontractor vehicles) for leaking oil and fluids. Do not allow leaking vehicles or equipment onsite.
- Always use secondary containment, such as a drain pan or drop cloth, to catch spills or leaks when removing or changing fluids.
- Place drip pans or absorbent materials under paving equipment when not in use.
- Use absorbent materials on small spills rather than hosing down or burying the spill. Remove the absorbent materials promptly and dispose of properly.
- Promptly transfer used fluids to the proper waste or recycling drums. Don't leave full drip pans or other open containers lying around
- Oil filters disposed of in trashcans or dumpsters can leak oil and pollute stormwater. Place the oil filter in a funnel over a waste oil-recycling drum to drain excess oil before disposal. Oil filters can also be recycled. Ask the oil supplier or recycler about recycling oil filters.
- Store cracked batteries in a non-leaking secondary container. Do this with all cracked batteries even if you think all the acid has drained out. If you drop a battery, treat it as if it is cracked. Put it into the containment area until you are sure it is not leaking.

Vehicle and Equipment Fueling

- If fueling must occur onsite, use designate areas, located away from drainage courses, to prevent the runoff of stormwater and the runoff of spills.
- Discourage "topping off" of fuel tanks.
- Always use secondary containment, such as a drain pan, when fueling to catch spills/ leaks.

Costs

Prevention of leaks and spills is inexpensive. Treatment and/ or disposal of contaminated soil or water can be quite expensive.

Inspection and Maintenance

- Inspect and verify that activity-based BMPs are in place prior to the commencement of associated activities. While activities associated with the BMP are under way, inspect BMPs in accordance with General Permit requirements for the associated project type and risk level. It is recommended that at a minimum, BMPs be inspected weekly, prior to forecasted rain events, daily during extended rain events, and after the conclusion of rain events.

- Inspect BMPs subject to non-stormwater discharge daily while non-stormwater discharges occur.
- Keep ample supplies of spill control and cleanup materials onsite, near storage, unloading, and maintenance areas.
- Update your spill prevention and control plan and stock cleanup materials as changes occur in the types of chemicals onsite.

References

Blueprint for a Clean Bay: Best Management Practices to Prevent Stormwater Pollution from Construction Related Activities; Santa Clara Valley Nonpoint Source Pollution Control Program, 1995.

Stormwater Quality Handbooks - Construction Site Best Management Practices (BMPs) Manual, State of California Department of Transportation (Caltrans), November 2000.

Stormwater Management for Construction Activities; Developing Pollution Prevention Plans and Best Management Practice, EPA 832-R-92005; USEPA, April 1992.

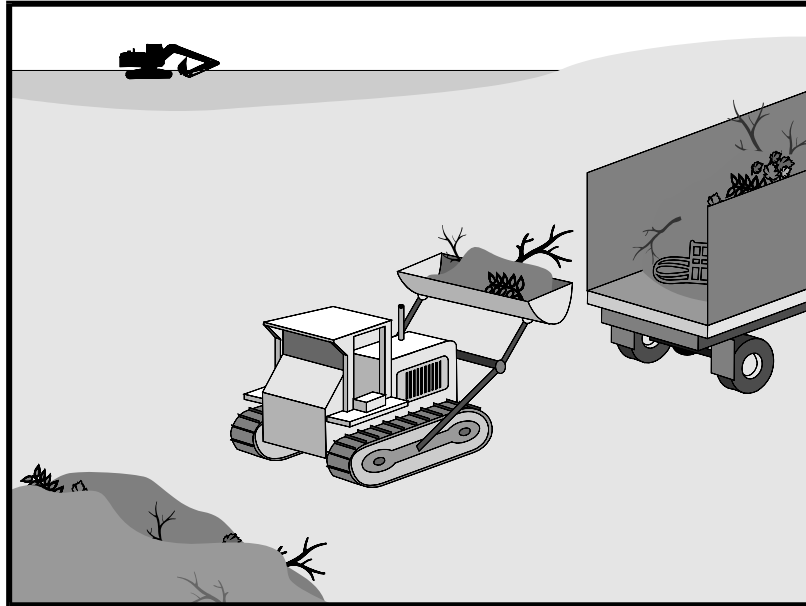

Description and Purpose

Solid waste management procedures and practices are designed to prevent or reduce the discharge of pollutants to stormwater from solid or construction waste by providing designated waste collection areas and containers, arranging for regular disposal, and training employees and subcontractors.

Suitable Applications

This BMP is suitable for construction sites where the following wastes are generated or stored:

- Solid waste generated from trees and shrubs removed during land clearing, demolition of existing structures (rubble), and building construction
- Packaging materials including wood, paper, and plastic
- Scrap or surplus building materials including scrap metals, rubber, plastic, glass pieces, and masonry products
- Domestic wastes including food containers such as beverage cans, coffee cups, paper bags, plastic wrappers, and cigarettes
- Construction wastes including brick, mortar, timber, steel and metal scraps, pipe and electrical cuttings, non-hazardous equipment parts, styrofoam and other materials used to transport and package construction materials

Categories

EC	Erosion Control	
SE	Sediment Control	
TC	Tracking Control	
WE	Wind Erosion Control	
NS	Non-Stormwater Management Control	
WM	Waste Management and Materials Pollution Control	<input checked="" type="checkbox"/>

Legend:

- Primary Objective
- Secondary Objective

Targeted Constituents

Sediment	<input checked="" type="checkbox"/>
Nutrients	<input checked="" type="checkbox"/>
Trash	<input checked="" type="checkbox"/>
Metals	<input checked="" type="checkbox"/>
Bacteria	
Oil and Grease	<input checked="" type="checkbox"/>
Organics	<input checked="" type="checkbox"/>

Potential Alternatives

None

If User/Subscriber modifies this fact sheet in any way, the CASQA name/logo and footer below must be removed from each page and not appear on the modified version.



- Highway planting wastes, including vegetative material, plant containers, and packaging materials

Limitations

Temporary stockpiling of certain construction wastes may not necessitate stringent drainage related controls during the non-rainy season or in desert areas with low rainfall.

Implementation

The following steps will help keep a clean site and reduce stormwater pollution:

- Select designated waste collection areas onsite.
- Inform trash-hauling contractors that you will accept only watertight dumpsters for onsite use. Inspect dumpsters for leaks and repair any dumpster that is not watertight.
- Locate containers in a covered area or in a secondary containment.
- Provide an adequate number of containers with lids or covers that can be placed over the container to keep rain out or to prevent loss of wastes when it is windy.
- Cover waste containers at the end of each work day and when it is raining.
- Plan for additional containers and more frequent pickup during the demolition phase of construction.
- Collect site trash daily, especially during rainy and windy conditions.
- Remove this solid waste promptly since erosion and sediment control devices tend to collect litter.
- Make sure that toxic liquid wastes (used oils, solvents, and paints) and chemicals (acids, pesticides, additives, curing compounds) are not disposed of in dumpsters designated for construction debris.
- Do not hose out dumpsters on the construction site. Leave dumpster cleaning to the trash hauling contractor.
- Arrange for regular waste collection before containers overflow.
- Clean up immediately if a container does spill.
- Make sure that construction waste is collected, removed, and disposed of only at authorized disposal areas.

Education

- Have the contractor's superintendent or representative oversee and enforce proper solid waste management procedures and practices.
- Instruct employees and subcontractors on identification of solid waste and hazardous waste.
- Educate employees and subcontractors on solid waste storage and disposal procedures.

- Hold regular meetings to discuss and reinforce disposal procedures (incorporate into regular safety meetings).
- Require that employees and subcontractors follow solid waste handling and storage procedures.
- Prohibit littering by employees, subcontractors, and visitors.
- Minimize production of solid waste materials wherever possible.

Collection, Storage, and Disposal

- Littering on the project site should be prohibited.
- To prevent clogging of the storm drainage system, litter and debris removal from drainage grates, trash racks, and ditch lines should be a priority.
- Trash receptacles should be provided in the contractor's yard, field trailer areas, and at locations where workers congregate for lunch and break periods.
- Litter from work areas within the construction limits of the project site should be collected and placed in watertight dumpsters at least weekly, regardless of whether the litter was generated by the contractor, the public, or others. Collected litter and debris should not be placed in or next to drain inlets, stormwater drainage systems, or watercourses.
- Dumpsters of sufficient size and number should be provided to contain the solid waste generated by the project.
- Full dumpsters should be removed from the project site and the contents should be disposed of by the trash hauling contractor.
- Construction debris and waste should be removed from the site biweekly or more frequently as needed.
- Construction material visible to the public should be stored or stacked in an orderly manner.
- Stormwater runoff should be prevented from contacting stored solid waste through the use of berms, dikes, or other temporary diversion structures or through the use of measures to elevate waste from site surfaces.
- Solid waste storage areas should be located at least 50 ft from drainage facilities and watercourses and should not be located in areas prone to flooding or ponding.
- Except during fair weather, construction and highway planting waste not stored in watertight dumpsters should be securely covered from wind and rain by covering the waste with tarps or plastic.
- Segregate potentially hazardous waste from non-hazardous construction site waste.
- Make sure that toxic liquid wastes (used oils, solvents, and paints) and chemicals (acids, pesticides, additives, curing compounds) are not disposed of in dumpsters designated for construction debris.

- For disposal of hazardous waste, see WM-6, Hazardous Waste Management. Have hazardous waste hauled to an appropriate disposal and/or recycling facility.
- Salvage or recycle useful vegetation debris, packaging and surplus building materials when practical. For example, trees and shrubs from land clearing can be used as a brush barrier, or converted into wood chips, then used as mulch on graded areas. Wood pallets, cardboard boxes, and construction scraps can also be recycled.

Costs

All of the above are low cost measures.

Inspection and Maintenance

- Inspect and verify that activity-based BMPs are in place prior to the commencement of associated activities. While activities associated with the BMP are under way, inspect BMPs in accordance with General Permit requirements for the associated project type and risk level. It is recommended that at a minimum, BMPs be inspected weekly, prior to forecasted rain events, daily during extended rain events, and after the conclusion of rain events.
- Inspect BMPs subject to non-stormwater discharge daily while non-stormwater discharges occur
- Inspect construction waste area regularly.
- Arrange for regular waste collection.

References

Processes, Procedures and Methods to Control Pollution Resulting from All Construction Activity, 430/9-73-007, USEPA, 1973.

Stormwater Quality Handbooks - Construction Site Best Management Practices (BMPs) Manual, State of California Department of Transportation (Caltrans), November 2000.

Stormwater Management for Construction Activities; Developing Pollution Prevention Plans and Best Management Practice, EPA 832-R-92005; USEPA, April 1992.

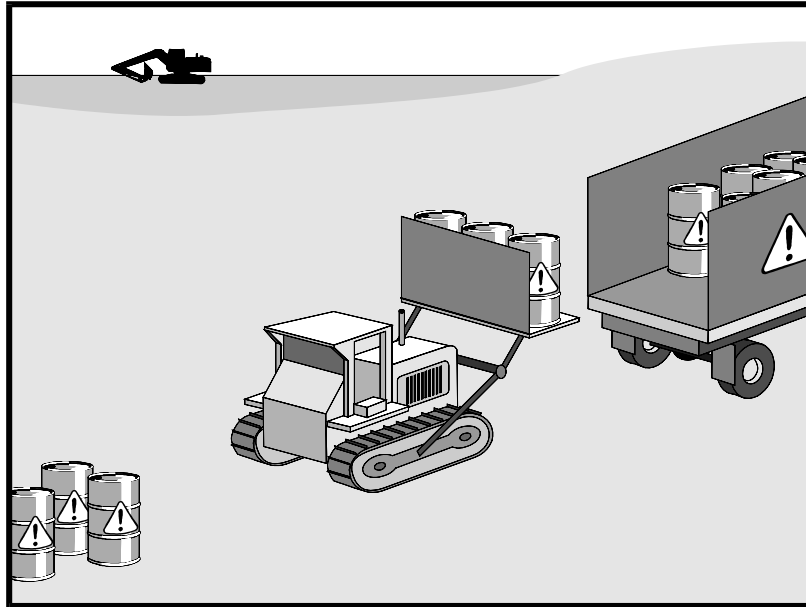

Categories

EC	Erosion Control	
SE	Sediment Control	
TC	Tracking Control	
WE	Wind Erosion Control	
NS	Non-Stormwater Management Control	
WM	Waste Management and Materials Pollution Control	<input checked="" type="checkbox"/>

Legend:

- Primary Objective
- Secondary Objective

Targeted Constituents

Sediment	
Nutrients	<input checked="" type="checkbox"/>
Trash	<input checked="" type="checkbox"/>
Metals	<input checked="" type="checkbox"/>
Bacteria	<input checked="" type="checkbox"/>
Oil and Grease	<input checked="" type="checkbox"/>
Organics	<input checked="" type="checkbox"/>

Potential Alternatives

None

If User/Subscriber modifies this fact sheet in any way, the CASQA name/logo and footer below must be removed from each page and not appear on the modified version.

Description and Purpose

Prevent or reduce the discharge of pollutants to stormwater from hazardous waste through proper material use, waste disposal, and training of employees and subcontractors.

Suitable Applications

This best management practice (BMP) applies to all construction projects. Hazardous waste management practices are implemented on construction projects that generate waste from the use of:

- Petroleum Products
- Concrete Curing Compounds
- Palliatives
- Septic Wastes
- Stains
- Wood Preservatives
- Asphalt Products
- Pesticides
- Acids
- Paints
- Solvents
- Roofing Tar
- Any materials deemed a hazardous waste in California, Title 22 Division 4.5, or listed in 40 CFR Parts 110, 117, 261, or 302



In addition, sites with existing structures may contain wastes, which must be disposed of in accordance with federal, state, and local regulations. These wastes include:

- Sandblasting grit mixed with lead-, cadmium-, or chromium-based paints
- Asbestos
- PCBs (particularly in older transformers)

Limitations

- Hazardous waste that cannot be reused or recycled must be disposed of by a licensed hazardous waste hauler.
- Nothing in this BMP relieves the contractor from responsibility for compliance with federal, state, and local laws regarding storage, handling, transportation, and disposal of hazardous wastes.
- This BMP does not cover aerially deposited lead (ADL) soils. For ADL soils refer to WM-7, Contaminated Soil Management.

Implementation

The following steps will help reduce stormwater pollution from hazardous wastes:

Material Use

- Wastes should be stored in sealed containers constructed of a suitable material and should be labeled as required by Title 22 CCR, Division 4.5 and 49 CFR Parts 172, 173, 178, and 179.
- All hazardous waste should be stored, transported, and disposed as required in Title 22 CCR, Division 4.5 and 49 CFR 261-263.
- Waste containers should be stored in temporary containment facilities that should comply with the following requirements:
 - Temporary containment facility should provide for a spill containment volume equal to 1.5 times the volume of all containers able to contain precipitation from a 25 year storm event, plus the greater of 10% of the aggregate volume of all containers or 100% of the capacity of the largest tank within its boundary, whichever is greater.
 - Temporary containment facility should be impervious to the materials stored there for a minimum contact time of 72 hours.
 - Temporary containment facilities should be maintained free of accumulated rainwater and spills. In the event of spills or leaks, accumulated rainwater and spills should be placed into drums after each rainfall. These liquids should be handled as a hazardous waste unless testing determines them to be non-hazardous. Non-hazardous liquids should be sent to an approved disposal site.
 - Sufficient separation should be provided between stored containers to allow for spill cleanup and emergency response access.

- Incompatible materials, such as chlorine and ammonia, should not be stored in the same temporary containment facility.
- Throughout the rainy season, temporary containment facilities should be covered during non-working days, and prior to rain events. Covered facilities may include use of plastic tarps for small facilities or constructed roofs with overhangs.
- Drums should not be overfilled and wastes should not be mixed.
- Unless watertight, containers of dry waste should be stored on pallets.
- Do not over-apply herbicides and pesticides. Prepare only the amount needed. Follow the recommended usage instructions. Over application is expensive and environmentally harmful. Apply surface dressings in several smaller applications, as opposed to one large application. Allow time for infiltration and avoid excess material being carried offsite by runoff. Do not apply these chemicals just before it rains. People applying pesticides must be certified in accordance with federal and state regulations.
- Paint brushes and equipment for water and oil based paints should be cleaned within a contained area and should not be allowed to contaminate site soils, watercourses, or drainage systems. Waste paints, thinners, solvents, residues, and sludges that cannot be recycled or reused should be disposed of as hazardous waste. When thoroughly dry, latex paint and paint cans, used brushes, rags, absorbent materials, and drop cloths should be disposed of as solid waste.
- Do not clean out brushes or rinse paint containers into the dirt, street, gutter, storm drain, or stream. "Paint out" brushes as much as possible. Rinse water-based paints to the sanitary sewer. Filter and reuse thinners and solvents. Dispose of excess oil-based paints and sludge as hazardous waste.
- The following actions should be taken with respect to temporary contaminant:
 - Ensure that adequate hazardous waste storage volume is available.
 - Ensure that hazardous waste collection containers are conveniently located.
 - Designate hazardous waste storage areas onsite away from storm drains or watercourses and away from moving vehicles and equipment to prevent accidental spills.
 - Minimize production or generation of hazardous materials and hazardous waste on the job site.
 - Use containment berms in fueling and maintenance areas and where the potential for spills is high.
 - Segregate potentially hazardous waste from non-hazardous construction site debris.
 - Keep liquid or semi-liquid hazardous waste in appropriate containers (closed drums or similar) and under cover.

- Clearly label all hazardous waste containers with the waste being stored and the date of accumulation.
- Place hazardous waste containers in secondary containment.
- Do not allow potentially hazardous waste materials to accumulate on the ground.
- Do not mix wastes.
- Use all of the product before disposing of the container.
- Do not remove the original product label; it contains important safety and disposal information.

Waste Recycling Disposal

- Select designated hazardous waste collection areas onsite.
- Hazardous materials and wastes should be stored in covered containers and protected from vandalism.
- Place hazardous waste containers in secondary containment.
- Do not mix wastes, this can cause chemical reactions, making recycling impossible and complicating disposal.
- Recycle any useful materials such as used oil or water-based paint.
- Make sure that toxic liquid wastes (used oils, solvents, and paints) and chemicals (acids, pesticides, additives, curing compounds) are not disposed of in dumpsters designated for construction debris.
- Arrange for regular waste collection before containers overflow.
- Make sure that hazardous waste (e.g., excess oil-based paint and sludge) is collected, removed, and disposed of only at authorized disposal areas.

Disposal Procedures

- Waste should be disposed of by a licensed hazardous waste transporter at an authorized and licensed disposal facility or recycling facility utilizing properly completed Uniform Hazardous Waste Manifest forms.
- A Department of Health Services certified laboratory should sample waste to determine the appropriate disposal facility.
- Properly dispose of rainwater in secondary containment that may have mixed with hazardous waste.
- Attention is directed to "Hazardous Material", "Contaminated Material", and "Aerially Deposited Lead" of the contract documents regarding the handling and disposal of hazardous materials.

Education

- Educate employees and subcontractors on hazardous waste storage and disposal procedures.
- Educate employees and subcontractors on potential dangers to humans and the environment from hazardous wastes.
- Instruct employees and subcontractors on safety procedures for common construction site hazardous wastes.
- Instruct employees and subcontractors in identification of hazardous and solid waste.
- Hold regular meetings to discuss and reinforce hazardous waste management procedures (incorporate into regular safety meetings).
- The contractor's superintendent or representative should oversee and enforce proper hazardous waste management procedures and practices.
- Make sure that hazardous waste is collected, removed, and disposed of only at authorized disposal areas.
- Warning signs should be placed in areas recently treated with chemicals.
- Place a stockpile of spill cleanup materials where it will be readily accessible.
- If a container does spill, clean up immediately.

Costs

All of the above are low cost measures.

Inspection and Maintenance

- Inspect and verify that activity-based BMPs are in place prior to the commencement of associated activities. While activities associated with the BMP are under way, inspect BMPs in accordance with General Permit requirements for the associated project type and risk level. It is recommended that at a minimum, BMPs be inspected weekly, prior to forecasted rain events, daily during extended rain events, and after the conclusion of rain events..
- Inspect BMPs subject to non-stormwater discharge daily while non-stormwater discharges occur
- Hazardous waste should be regularly collected.
- A foreman or construction supervisor should monitor onsite hazardous waste storage and disposal procedures.
- Waste storage areas should be kept clean, well organized, and equipped with ample cleanup supplies as appropriate for the materials being stored.
- Perimeter controls, containment structures, covers, and liners should be repaired or replaced as needed to maintain proper function.

- Hazardous spills should be cleaned up and reported in conformance with the applicable Material Safety Data Sheet (MSDS) and the instructions posted at the project site.
- The National Response Center, at (800) 424-8802, should be notified of spills of federal reportable quantities in conformance with the requirements in 40 CFR parts 110, 117, and 302. Also notify the Governors Office of Emergency Services Warning Center at (916) 845-8911.
- A copy of the hazardous waste manifests should be provided.

References

Blueprint for a Clean Bay: Best Management Practices to Prevent Stormwater Pollution from Construction Related Activities; Santa Clara Valley Nonpoint Source Pollution Control Program, 1995.

Processes, Procedures and Methods to Control Pollution Resulting from All Construction Activity, 430/9-73-007, USEPA, 1973.

Stormwater Quality Handbooks - Construction Site Best Management Practices (BMPs) Manual, State of California Department of Transportation (Caltrans), November 2000.

Stormwater Management for Construction Activities; Developing Pollution Prevention Plans and Best Management Practice, EPA 832-R-92005; USEPA, April 1992.

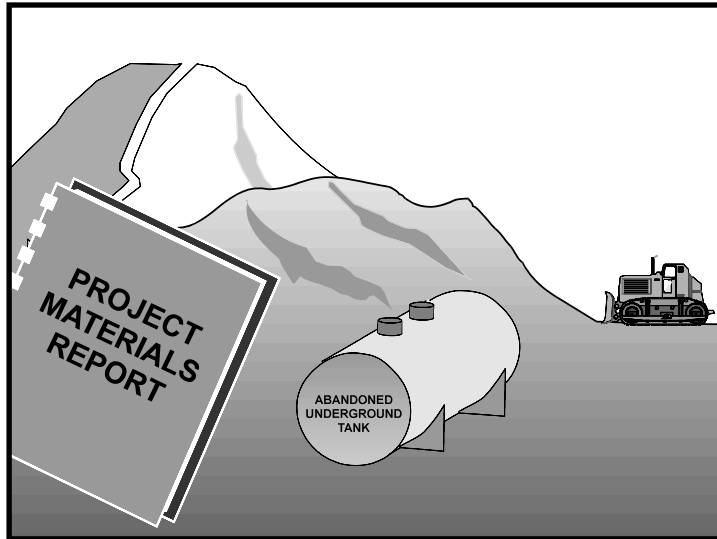

Categories

EC	Erosion Control	
SE	Sediment Control	
TC	Tracking Control	
WE	Wind Erosion Control	
NS	Non-Stormwater Management Control	
WM	Waste Management and Materials Pollution Control	<input checked="" type="checkbox"/>

Legend:

- Primary Objective
- Secondary Objective

Description and Purpose

Prevent or reduce the discharge of pollutants to stormwater from contaminated soil and highly acidic or alkaline soils by conducting pre-construction surveys, inspecting excavations regularly, and remediating contaminated soil promptly.

Suitable Applications

Contaminated soil management is implemented on construction projects in highly urbanized or industrial areas where soil contamination may have occurred due to spills, illicit discharges, aerial deposition, past use and leaks from underground storage tanks.

Limitations

Contaminated soils that cannot be treated onsite must be disposed of offsite by a licensed hazardous waste hauler. The presence of contaminated soil may indicate contaminated water as well. See NS-2, Dewatering Operations, for more information.

The procedures and practices presented in this BMP are general. The contractor should identify appropriate practices and procedures for the specific contaminants known to exist or discovered onsite.

Implementation

Most owners and developers conduct pre-construction environmental assessments as a matter of routine. Contaminated soils are often identified during project planning and development with known locations identified in the plans, specifications and in the SWPPP. The contractor should review applicable reports and investigate appropriate call-outs in the

Targeted Constituents

Sediment	
Nutrients	<input checked="" type="checkbox"/>
Trash	<input checked="" type="checkbox"/>
Metals	<input checked="" type="checkbox"/>
Bacteria	<input checked="" type="checkbox"/>
Oil and Grease	<input checked="" type="checkbox"/>
Organics	<input checked="" type="checkbox"/>

Potential Alternatives

None

If User/Subscriber modifies this fact sheet in any way, the CASQA name/logo and footer below must be removed from each page and not appear on the modified version.



plans, specifications, and SWPPP. Recent court rulings holding contractors liable for cleanup costs when they unknowingly move contaminated soil highlight the need for contractors to confirm a site assessment is completed before earth moving begins.

The following steps will help reduce stormwater pollution from contaminated soil:

- Conduct thorough, pre-construction inspections of the site and review documents related to the site. If inspection or reviews indicated presence of contaminated soils, develop a plan before starting work.
- Look for contaminated soil as evidenced by discoloration, odors, differences in soil properties, abandoned underground tanks or pipes, or buried debris.
- Prevent leaks and spills. Contaminated soil can be expensive to treat and dispose of properly. However, addressing the problem before construction is much less expensive than after the structures are in place.
- The contractor may further identify contaminated soils by investigating:
 - Past site uses and activities
 - Detected or undetected spills and leaks
 - Acid or alkaline solutions from exposed soil or rock formations high in acid or alkaline forming elements
 - Contaminated soil as evidenced by discoloration, odors, differences in soil properties, abandoned underground tanks or pipes, or buried debris.
 - Suspected soils should be tested at a certified laboratory.

Education

- Have employees and subcontractors complete a safety training program which meets 29 CFR 1910.120 and 8 CCR 5192 covering the potential hazards as identified, prior to performing any excavation work at the locations containing material classified as hazardous.
- Educate employees and subcontractors in identification of contaminated soil and on contaminated soil handling and disposal procedures.
- Hold regular meetings to discuss and reinforce disposal procedures (incorporate into regular safety meetings).

Handling Procedures for Material with Aerially Deposited Lead (ADL)

- Materials from areas designated as containing (ADL) may, if allowed by the contract special provisions, be excavated, transported, and used in the construction of embankments and/or backfill.
- Excavation, transportation, and placement operations should result in no visible dust.
- Caution should be exercised to prevent spillage of lead containing material during transport.

- Quality should be monitored during excavation of soils contaminated with lead.

Handling Procedures for Contaminated Soils

- Minimize onsite storage. Contaminated soil should be disposed of properly in accordance with all applicable regulations. All hazardous waste storage will comply with the requirements in Title 22, CCR, Sections 66265.250 to 66265.260.
- Test suspected soils at an approved certified laboratory.
- Work with the local regulatory agencies to develop options for treatment or disposal if the soil is contaminated.
- Avoid temporary stockpiling of contaminated soils or hazardous material.
- Take the following precautions if temporary stockpiling is necessary:
 - Cover the stockpile with plastic sheeting or tarps.
 - Install a berm around the stockpile to prevent runoff from leaving the area.
 - Do not stockpile in or near storm drains or watercourses.
- Remove contaminated material and hazardous material on exteriors of transport vehicles and place either into the current transport vehicle or into the excavation prior to the vehicle leaving the exclusion zone.
- Monitor the air quality continuously during excavation operations at all locations containing hazardous material.
- Procure all permits and licenses, pay all charges and fees, and give all notices necessary and incident to the due and lawful prosecution of the work, including registration for transporting vehicles carrying the contaminated material and the hazardous material.
- Collect water from decontamination procedures and treat or dispose of it at an appropriate disposal site.
- Collect non-reusable protective equipment, once used by any personnel, and dispose of at an appropriate disposal site.
- Install temporary security fence to surround and secure the exclusion zone. Remove fencing when no longer needed.
- Excavate, transport, and dispose of contaminated material and hazardous material in accordance with the rules and regulations of the following agencies (the specifications of these agencies supersede the procedures outlined in this BMP):
 - United States Department of Transportation (USDOT)
 - United States Environmental Protection Agency (USEPA)
 - California Environmental Protection Agency (CAL-EPA)

- California Division of Occupation Safety and Health Administration (CAL-OSHA)
- Local regulatory agencies

Procedures for Underground Storage Tank Removals

- Prior to commencing tank removal operations, obtain the required underground storage tank removal permits and approval from the federal, state, and local agencies that have jurisdiction over such work.
- To determine if it contains hazardous substances, arrange to have tested, any liquid or sludge found in the underground tank prior to its removal.
- Following the tank removal, take soil samples beneath the excavated tank and perform analysis as required by the local agency representative(s).
- The underground storage tank, any liquid or sludge found within the tank, and all contaminated substances and hazardous substances removed during the tank removal and transported to disposal facilities permitted to accept such waste.

Water Control

- All necessary precautions and preventive measures should be taken to prevent the flow of water, including ground water, from mixing with hazardous substances or underground storage tank excavations. Such preventative measures may consist of, but are not limited to, berms, cofferdams, grout curtains, freeze walls, and seal course concrete or any combination thereof.
- If water does enter an excavation and becomes contaminated, such water, when necessary to proceed with the work, should be discharged to clean, closed top, watertight transportable holding tanks, treated, and disposed of in accordance with federal, state, and local laws.

Costs

Prevention of leaks and spills is inexpensive. Treatment or disposal of contaminated soil can be quite expensive.

Inspection and Maintenance

- Inspect and verify that activity-based BMPs are in place prior to the commencement of associated activities. While activities associated with the BMP are under way, inspect BMPs in accordance with General Permit requirements for the associated project type and risk level. It is recommended that at a minimum, BMPs be inspected weekly, prior to forecasted rain events, daily during extended rain events, and after the conclusion of rain events.
- Arrange for contractor's Water Pollution Control Manager, foreman, and/or construction supervisor to monitor onsite contaminated soil storage and disposal procedures.
- Monitor air quality continuously during excavation operations at all locations containing hazardous material.
- Coordinate contaminated soils and hazardous substances/waste management with the appropriate federal, state, and local agencies.

- Implement WM-4, Spill Prevention and Control, to prevent leaks and spills as much as possible.

References

Blueprint for a Clean Bay: Best Management Practices to Prevent Stormwater Pollution from Construction Related Activities; Santa Clara Valley Nonpoint Source Pollution Control Program, 1995.

Processes, Procedures and Methods to Control Pollution Resulting from All Construction Activity, 430/9-73-007, USEPA, 1973.

Stormwater Quality Handbooks - Construction Site Best Management Practices (BMPs) Manual, State of California Department of Transportation (Caltrans), November 2000.

Stormwater Management for Construction Activities; Developing Pollution Prevention Plans and Best Management Practice, EPA 832-R-92005; USEPA, April 1992.

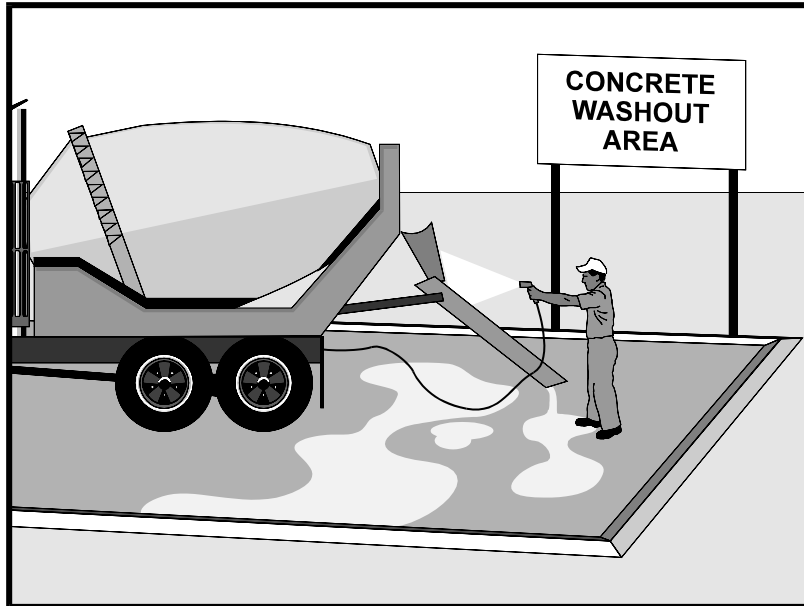

Description and Purpose

Prevent the discharge of pollutants to stormwater from concrete waste by conducting washout onsite or offsite in a designated area, and by employee and subcontractor training.

The General Permit incorporates Numeric Action Levels (NAL) for pH (see Section 2 of this handbook to determine your project's risk level and if you are subject to these requirements).

Many types of construction materials, including mortar, concrete, stucco, cement and block and their associated wastes have basic chemical properties that can raise pH levels outside of the permitted range. Additional care should be taken when managing these materials to prevent them from coming into contact with stormwater flows and raising pH to levels outside the accepted range.

Suitable Applications

Concrete waste management procedures and practices are implemented on construction projects where:

- Concrete is used as a construction material or where concrete dust and debris result from demolition activities.
- Slurries containing portland cement concrete (PCC) are generated, such as from saw cutting, coring, grinding, grooving, and hydro-concrete demolition.
- Concrete trucks and other concrete-coated equipment are washed onsite.

Categories

EC	Erosion Control	
SE	Sediment Control	
TC	Tracking Control	
WE	Wind Erosion Control	
NS	Non-Stormwater Management Control	<input checked="" type="checkbox"/>
WM	Waste Management and Materials Pollution Control	<input checked="" type="checkbox"/>

Legend:

- Primary Category
- Secondary Category

Targeted Constituents

Sediment	<input checked="" type="checkbox"/>
Nutrients	
Trash	
Metals	<input checked="" type="checkbox"/>
Bacteria	
Oil and Grease	
Organics	

Potential Alternatives

None

If User/Subscriber modifies this fact sheet in any way, the CASQA name/logo and footer below must be removed from each page and not appear on the modified version.



- Mortar-mixing stations exist.
- Stucco mixing and spraying.
- See also NS-8, Vehicle and Equipment Cleaning.

Limitations

- Offsite washout of concrete wastes may not always be possible.
- Multiple washouts may be needed to assure adequate capacity and to allow for evaporation.

Implementation

The following steps will help reduce stormwater pollution from concrete wastes:

- Incorporate requirements for concrete waste management into material supplier and subcontractor agreements.
- Store dry and wet materials under cover, away from drainage areas. Refer to WM-1, Material Delivery and Storage for more information.
- Avoid mixing excess amounts of concrete.
- Perform washout of concrete trucks in designated areas only, where washout will not reach stormwater.
- Do not wash out concrete trucks into storm drains, open ditches, streets, streams or onto the ground. Trucks should always be washed out into designated facilities.
- Do not allow excess concrete to be dumped onsite, except in designated areas.
- For onsite washout:
 - On larger sites, it is recommended to locate washout areas at least 50 feet from storm drains, open ditches, or water bodies. Do not allow runoff from this area by constructing a temporary pit or bermed area large enough for liquid and solid waste.
 - Washout wastes into the temporary washout where the concrete can set, be broken up, and then disposed properly.
 - Washouts shall be implemented in a manner that prevents leaching to underlying soils. Washout containers must be water tight and washouts on or in the ground must be lined with a suitable impervious liner, typically a plastic type material.
- Do not wash sweepings from exposed aggregate concrete into the street or storm drain. Collect and return sweepings to aggregate base stockpile or dispose in the trash.
- See typical concrete washout installation details at the end of this fact sheet.

Education

- Educate employees, subcontractors, and suppliers on the concrete waste management techniques described herein.

- Arrange for contractor's superintendent or representative to oversee and enforce concrete waste management procedures.
- Discuss the concrete management techniques described in this BMP (such as handling of concrete waste and washout) with the ready-mix concrete supplier before any deliveries are made.

Concrete Demolition Wastes

- Stockpile concrete demolition waste in accordance with BMP WM-3, Stockpile Management.
- Dispose of or recycle hardened concrete waste in accordance with applicable federal, state or local regulations.

Concrete Slurry Wastes

- PCC and AC waste should not be allowed to enter storm drains or watercourses.
- PCC and AC waste should be collected and disposed of or placed in a temporary concrete washout facility (as described in Onsite Temporary Concrete Washout Facility, Concrete Transit Truck Washout Procedures, below).
- A foreman or construction supervisor should monitor onsite concrete working tasks, such as saw cutting, coring, grinding and grooving to ensure proper methods are implemented.
- Saw-cut concrete slurry should not be allowed to enter storm drains or watercourses. Residue from grinding operations should be picked up by means of a vacuum attachment to the grinding machine or by sweeping. Saw cutting residue should not be allowed to flow across the pavement and should not be left on the surface of the pavement. See also NS-3, Paving and Grinding Operations; and WM-10, Liquid Waste Management.
- Concrete slurry residue should be disposed in a temporary washout facility (as described in Onsite Temporary Concrete Washout Facility, Concrete Transit Truck Washout Procedures, below) and allowed to dry. Dispose of dry slurry residue in accordance with WM-5, Solid Waste Management.

Onsite Temporary Concrete Washout Facility, Transit Truck Washout Procedures

- Temporary concrete washout facilities should be located a minimum of 50 ft from storm drain inlets, open drainage facilities, and watercourses. Each facility should be located away from construction traffic or access areas to prevent disturbance or tracking.
- A sign should be installed adjacent to each washout facility to inform concrete equipment operators to utilize the proper facilities.
- Temporary concrete washout facilities should be constructed above grade or below grade at the option of the contractor. Temporary concrete washout facilities should be constructed and maintained in sufficient quantity and size to contain all liquid and concrete waste generated by washout operations.

- Temporary washout facilities should have a temporary pit or bermed areas of sufficient volume to completely contain all liquid and waste concrete materials generated during washout procedures.
- Temporary washout facilities should be lined to prevent discharge to the underlying ground or surrounding area.
- Washout of concrete trucks should be performed in designated areas only.
- Only concrete from mixer truck chutes should be washed into concrete wash out.
- Concrete washout from concrete pumper bins can be washed into concrete pumper trucks and discharged into designated washout area or properly disposed of or recycled offsite.
- Once concrete wastes are washed into the designated area and allowed to harden, the concrete should be broken up, removed, and disposed of per WM-5, Solid Waste Management. Dispose of or recycle hardened concrete on a regular basis.
- Temporary Concrete Washout Facility (Type Above Grade)
 - Temporary concrete washout facility (type above grade) should be constructed as shown on the details at the end of this BMP, with a recommended minimum length and minimum width of 10 ft; however, smaller sites or jobs may only need a smaller washout facility. With any washout, always maintain a sufficient quantity and volume to contain all liquid and concrete waste generated by washout operations.
 - Materials used to construct the washout area should conform to the provisions detailed in their respective BMPs (e.g., SE-8 Sandbag Barrier).
 - Plastic lining material should be a minimum of 10 mil in polyethylene sheeting and should be free of holes, tears, or other defects that compromise the impermeability of the material.
 - Alternatively, portable removable containers can be used as above grade concrete washouts. Also called a “roll-off”; this concrete washout facility should be properly sealed to prevent leakage, and should be removed from the site and replaced when the container reaches 75% capacity.
- Temporary Concrete Washout Facility (Type Below Grade)
 - Temporary concrete washout facilities (type below grade) should be constructed as shown on the details at the end of this BMP, with a recommended minimum length and minimum width of 10 ft. The quantity and volume should be sufficient to contain all liquid and concrete waste generated by washout operations.
 - Lath and flagging should be commercial type.
 - Plastic lining material should be a minimum of 10 mil polyethylene sheeting and should be free of holes, tears, or other defects that compromise the impermeability of the material.

- The base of a washout facility should be free of rock or debris that may damage a plastic liner.

Removal of Temporary Concrete Washout Facilities

- When temporary concrete washout facilities are no longer required for the work, the hardened concrete should be removed and properly disposed or recycled in accordance with federal, state or local regulations. Materials used to construct temporary concrete washout facilities should be removed from the site of the work and properly disposed or recycled in accordance with federal, state or local regulations..
- Holes, depressions or other ground disturbance caused by the removal of the temporary concrete washout facilities should be backfilled and repaired.

Costs

All of the above are low cost measures. Roll-Off concrete washout facilities can be more costly than other measures due to removal and replacement; however, provide a cleaner alternative to traditional washouts. The type of washout facility, size, and availability of materials will determine the cost of the washout.

Inspection and Maintenance

- BMPs must be inspected in accordance with General Permit requirements for the associated project type and risk level. It is recommended that at a minimum, BMPs be inspected weekly, prior to forecasted rain events, daily during extended rain events, and after the conclusion of rain events.
- Temporary concrete washout facilities should be maintained to provide adequate holding capacity with a minimum freeboard of 4 in. for above grade facilities and 12 in. for below grade facilities. Maintaining temporary concrete washout facilities should include removing and disposing of hardened concrete and returning the facilities to a functional condition. Hardened concrete materials should be removed and properly disposed or recycled in accordance with federal, state or local regulations.
- Washout facilities must be cleaned, or new facilities must be constructed and ready for use once the washout is 75% full.
- Inspect washout facilities for damage (e.g. torn liner, evidence of leaks, signage, etc.). Repair all identified damage.

References

Blueprint for a Clean Bay: Best Management Practices to Prevent Stormwater Pollution from Construction Related Activities; Santa Clara Valley Nonpoint Source Pollution Control Program, 1995.

Stormwater Quality Handbooks - Construction Site Best Management Practices (BMPs) Manual, State of California Department of Transportation (Caltrans), November 2000, Updated March 2003.

Stormwater Management for Construction Activities; Developing Pollution Prevention Plans and Best Management Practice, EPA 832-R-92005; USEPA, April 1992.

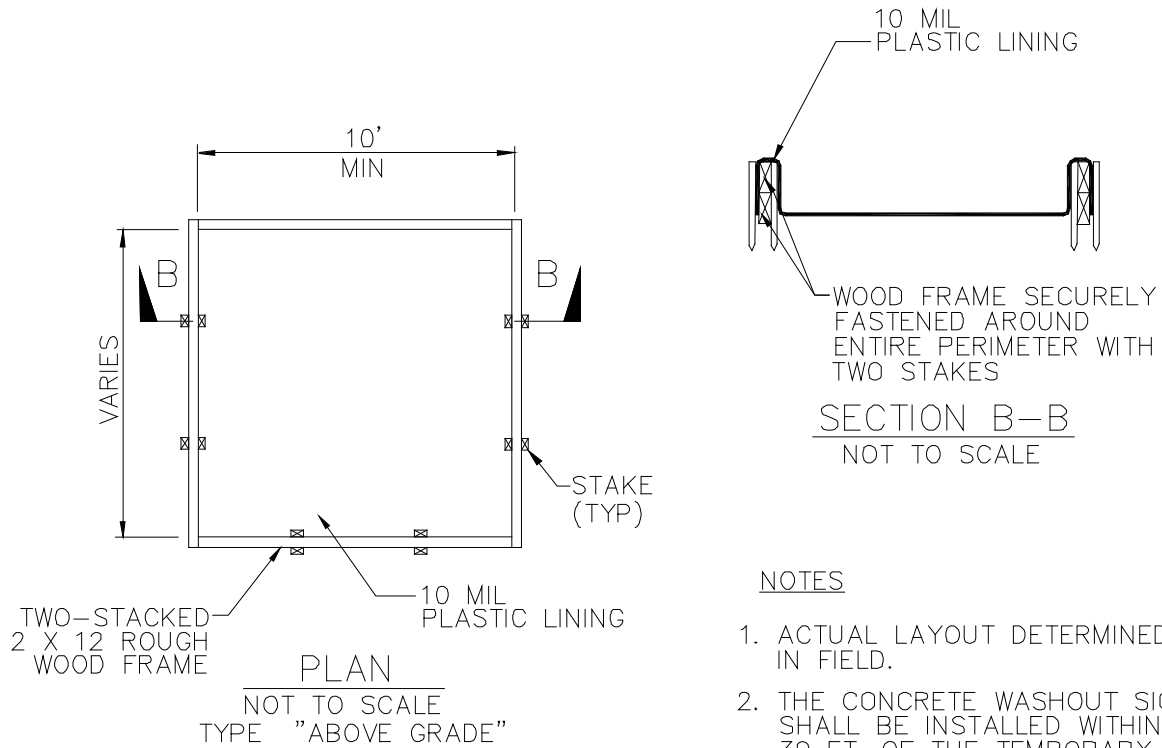
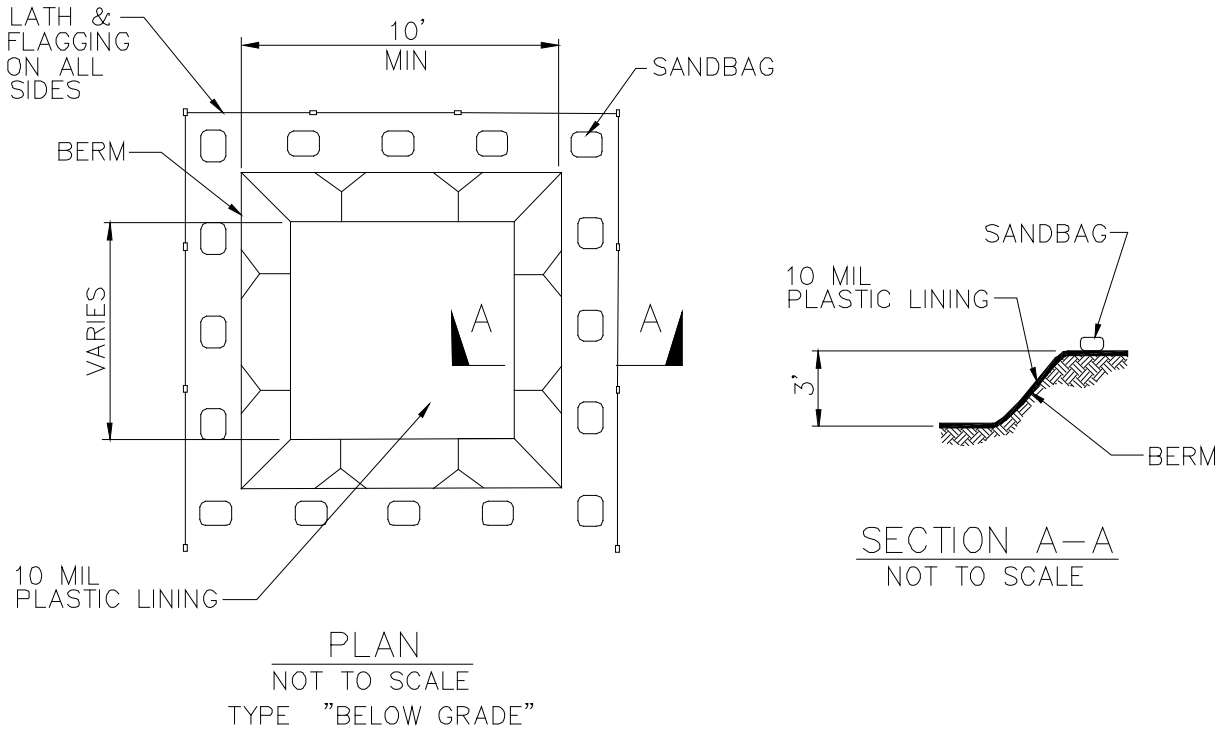

NOTES

1. ACTUAL LAYOUT DETERMINED IN FIELD.
2. THE CONCRETE WASHOUT SIGN SHALL BE INSTALLED WITHIN 30 FT. OF THE TEMPORARY CONCRETE WASHOUT FACILITY.

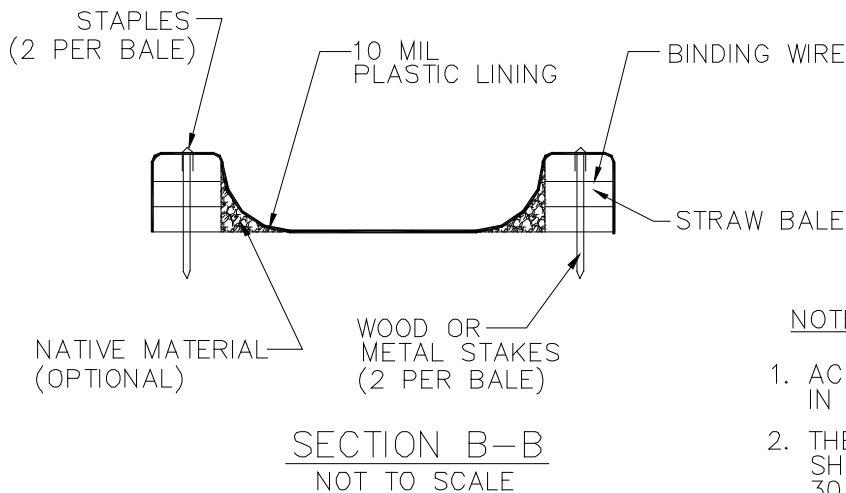
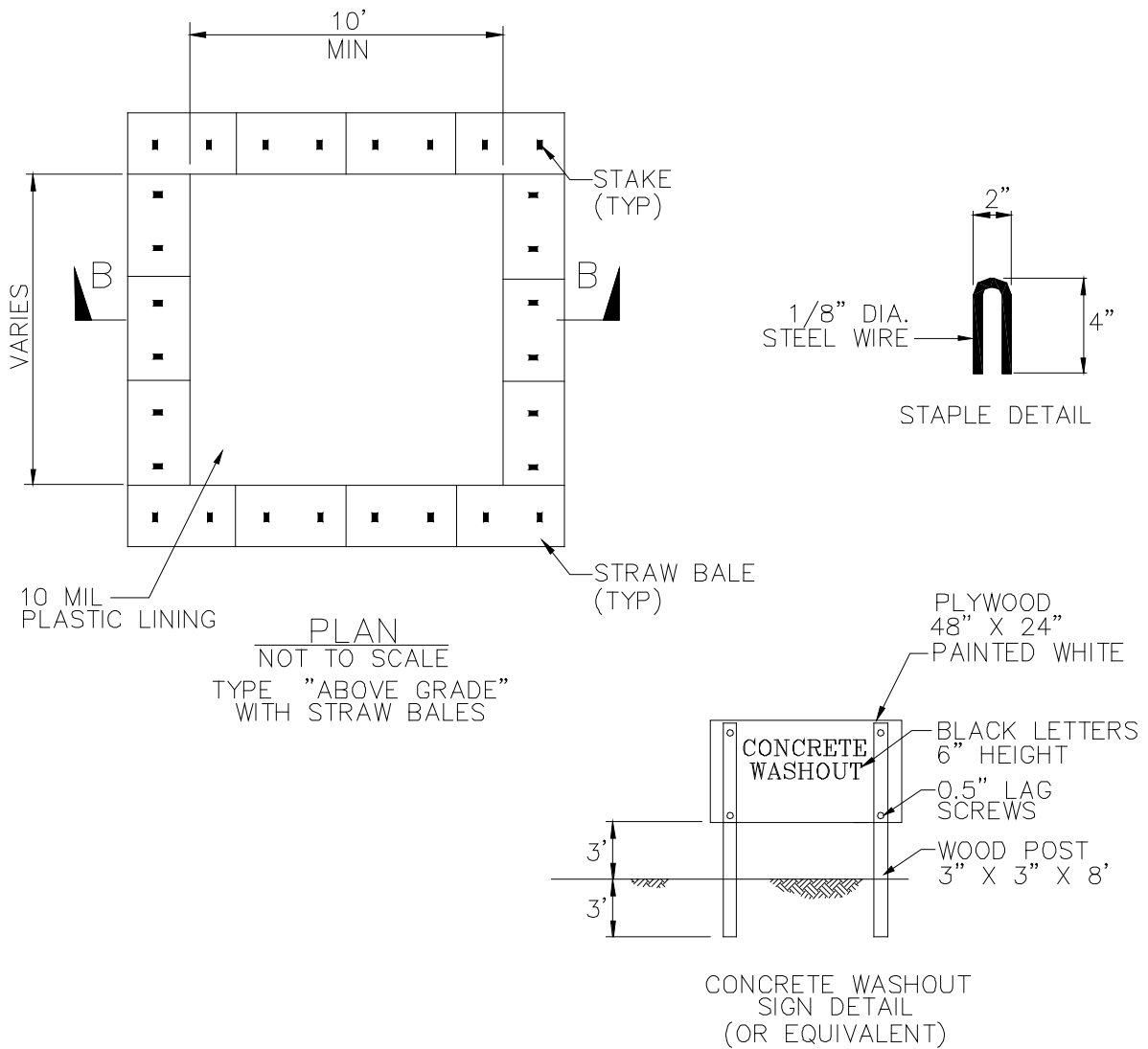

NOTES

1. ACTUAL LAYOUT DETERMINED IN FIELD.
2. THE CONCRETE WASHOUT SIGN SHALL BE INSTALLED WITHIN 30 FT. OF THE TEMPORARY CONCRETE WASHOUT FACILITY.

Sanitary/Septic Waste Management WM-9

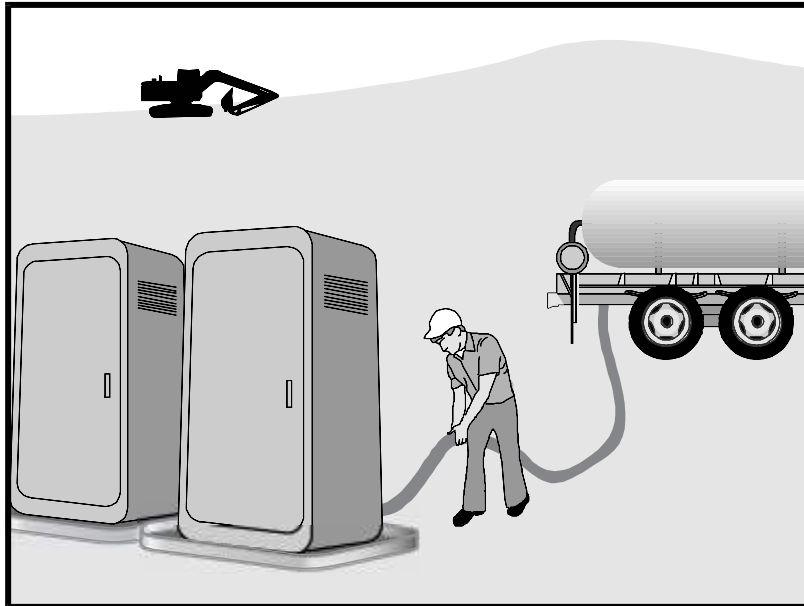

Description and Purpose

Proper sanitary and septic waste management prevent the discharge of pollutants to stormwater from sanitary and septic waste by providing convenient, well-maintained facilities, and arranging for regular service and disposal.

Suitable Applications

Sanitary septic waste management practices are suitable for use at all construction sites that use temporary or portable sanitary and septic waste systems.

Limitations

None identified.

Implementation

Sanitary or septic wastes should be treated or disposed of in accordance with state and local requirements. In many cases, one contract with a local facility supplier will be all that it takes to make sure sanitary wastes are properly disposed.

Storage and Disposal Procedures

- Temporary sanitary facilities should be located away from drainage facilities, watercourses, and from traffic circulation. If site conditions allow, place portable facilities a minimum of 50 feet from drainage conveyances and traffic areas. When subjected to high winds or risk of high winds, temporary sanitary facilities should be secured to prevent overturning.

Categories

EC	Erosion Control	
SE	Sediment Control	
TC	Tracking Control	
WE	Wind Erosion Control	
NS	Non-Stormwater Management Control	
WM	Waste Management and Materials Pollution Control	<input checked="" type="checkbox"/>

Legend:

- Primary Category
- Secondary Category

Targeted Constituents

Sediment	
Nutrients	<input checked="" type="checkbox"/>
Trash	<input checked="" type="checkbox"/>
Metals	
Bacteria	<input checked="" type="checkbox"/>
Oil and Grease	
Organics	<input checked="" type="checkbox"/>

Potential Alternatives

None

If User/Subscriber modifies this fact sheet in any way, the CASQA name/logo and footer below must be removed from each page and not appear on the modified version.



Sanitary/Septic Waste Management WM-9

- Temporary sanitary facilities must be equipped with containment to prevent discharge of pollutants to the stormwater drainage system of the receiving water.
- Consider safety as well as environmental implications before placing temporary sanitary facilities.
- Wastewater should not be discharged or buried within the project site.
- Sanitary and septic systems that discharge directly into sanitary sewer systems, where permissible, should comply with the local health agency, city, county, and sewer district requirements.
- Only reputable, licensed sanitary and septic waste haulers should be used.
- Sanitary facilities should be located in a convenient location.
- Temporary septic systems should treat wastes to appropriate levels before discharging.
- If using an onsite disposal system (OSDS), such as a septic system, local health agency requirements must be followed.
- Temporary sanitary facilities that discharge to the sanitary sewer system should be properly connected to avoid illicit discharges.
- Sanitary and septic facilities should be maintained in good working order by a licensed service.
- Regular waste collection by a licensed hauler should be arranged before facilities overflow.
- If a spill does occur from a temporary sanitary facility, follow federal, state and local regulations for containment and clean-up.

Education

- Educate employees, subcontractors, and suppliers on sanitary and septic waste storage and disposal procedures.
- Educate employees, subcontractors, and suppliers of potential dangers to humans and the environment from sanitary and septic wastes.
- Instruct employees, subcontractors, and suppliers in identification of sanitary and septic waste.
- Hold regular meetings to discuss and reinforce the use of sanitary facilities (incorporate into regular safety meetings).
- Establish a continuing education program to indoctrinate new employees.

Costs

All of the above are low cost measures.

Sanitary/Septic Waste Management WM-9

Inspection and Maintenance

- BMPs must be inspected in accordance with General Permit requirements for the associated project type and risk level. It is recommended that at a minimum, BMPs be inspected weekly, prior to forecasted rain events, daily during extended rain events, and after the conclusion of rain events.
- Arrange for regular waste collection.
- If high winds are expected, portable sanitary facilities must be secured with spikes or weighed down to prevent over turning.
- If spills or leaks from sanitary or septic facilities occur that are not contained and discharge from the site, non-visible sampling of site discharge may be required. Refer to the General Permit or to your project specific Construction Site Monitoring Plan to determine if and where sampling is required.

References

Stormwater Quality Handbooks - Construction Site Best Management Practices (BMPs) Manual, State of California Department of Transportation (Caltrans), March 2003.

Stormwater Management for Construction Activities; Developing Pollution Prevention Plans and Best Management Practice, EPA 832-R-92005; USEPA, April 1992.

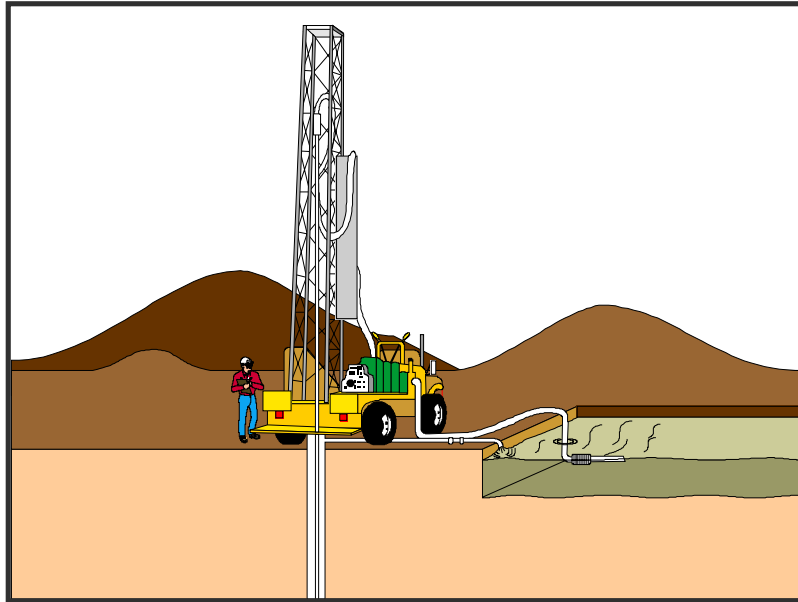

Description and Purpose

Liquid waste management includes procedures and practices to prevent discharge of pollutants to the storm drain system or to watercourses as a result of the creation, collection, and disposal of non-hazardous liquid wastes.

Suitable Applications

Liquid waste management is applicable to construction projects that generate any of the following non-hazardous by-products, residuals, or wastes:

- Drilling slurries and drilling fluids
- Grease-free and oil-free wastewater and rinse water
- Dredgings
- Other non-stormwater liquid discharges not permitted by separate permits

Limitations

- Disposal of some liquid wastes may be subject to specific laws and regulations or to requirements of other permits secured for the construction project (e.g., NPDES permits, Army Corps permits, Coastal Commission permits, etc.).
- Liquid waste management does not apply to dewatering operations (NS-2 Dewatering Operations), solid waste management (WM-5, Solid Waste Management), hazardous wastes (WM-6, Hazardous Waste Management), or

Categories

EC	Erosion Control	
SE	Sediment Control	
TC	Tracking Control	
WE	Wind Erosion Control	
NS	Non-Stormwater Management Control	
WM	Waste Management and Materials Pollution Control	<input checked="" type="checkbox"/>

Legend:

- Primary Objective
- Secondary Objective

Targeted Constituents

Sediment	<input checked="" type="checkbox"/>
Nutrients	<input checked="" type="checkbox"/>
Trash	<input checked="" type="checkbox"/>
Metals	<input checked="" type="checkbox"/>
Bacteria	
Oil and Grease	<input checked="" type="checkbox"/>
Organics	

Potential Alternatives

None

If User/Subscriber modifies this fact sheet in any way, the CASQA name/logo and footer below must be removed from each page and not appear on the modified version.



concrete slurry residue (WM-8, Concrete Waste Management).

- Typical permitted non-stormwater discharges can include: water line flushing; landscape irrigation; diverted stream flows; rising ground waters; uncontaminated pumped ground water; discharges from potable water sources; foundation drains; irrigation water; springs; water from crawl space pumps; footing drains; lawn watering; flows from riparian habitats and wetlands; and discharges or flows from emergency fire fighting activities.

Implementation

General Practices

- Instruct employees and subcontractors how to safely differentiate between non-hazardous liquid waste and potential or known hazardous liquid waste.
- Instruct employees, subcontractors, and suppliers that it is unacceptable for any liquid waste to enter any storm drainage device, waterway, or receiving water.
- Educate employees and subcontractors on liquid waste generating activities and liquid waste storage and disposal procedures.
- Hold regular meetings to discuss and reinforce disposal procedures (incorporate into regular safety meetings).
- Verify which non-stormwater discharges are permitted by the statewide NPDES permit; different regions might have different requirements not outlined in this permit.
- Apply NS-8, Vehicle and Equipment Cleaning for managing wash water and rinse water from vehicle and equipment cleaning operations.

Containing Liquid Wastes

- Drilling residue and drilling fluids should not be allowed to enter storm drains and watercourses and should be disposed of.
- If an appropriate location is available, drilling residue and drilling fluids that are exempt under Title 23, CCR § 2511(g) may be dried by infiltration and evaporation in a containment facility constructed in conformance with the provisions concerning the Temporary Concrete Washout Facilities detailed in WM-8, Concrete Waste Management.
- Liquid wastes generated as part of an operational procedure, such as water-laden dredged material and drilling mud, should be contained and not allowed to flow into drainage channels or receiving waters prior to treatment.
- Liquid wastes should be contained in a controlled area such as a holding pit, sediment basin, roll-off bin, or portable tank.
- Containment devices must be structurally sound and leak free.
- Containment devices must be of sufficient quantity or volume to completely contain the liquid wastes generated.

- Precautions should be taken to avoid spills or accidental releases of contained liquid wastes. Apply the education measures and spill response procedures outlined in WM-4, Spill Prevention and Control.
- Containment areas or devices should not be located where accidental release of the contained liquid can threaten health or safety or discharge to water bodies, channels, or storm drains.

Capturing Liquid Wastes

- Capture all liquid wastes that have the potential to affect the storm drainage system (such as wash water and rinse water from cleaning walls or pavement), before they run off a surface.
- Do not allow liquid wastes to flow or discharge uncontrolled. Use temporary dikes or berms to intercept flows and direct them to a containment area or device for capture.
- Use a sediment trap (SE-3, Sediment Trap) for capturing and treating sediment laden liquid waste or capture in a containment device and allow sediment to settle.

Disposing of Liquid Wastes

- A typical method to handle liquid waste is to dewater the contained liquid waste, using procedures such as described in NS-2, Dewatering Operations, and SE-2, Sediment Basin, and dispose of resulting solids per WM-5, Solid Waste Management.
- Methods of disposal for some liquid wastes may be prescribed in Water Quality Reports, NPDES permits, Environmental Impact Reports, 401 or 404 permits, and local agency discharge permits, etc. Review the SWPPP to see if disposal methods are identified.
- Liquid wastes, such as from dredged material, may require testing and certification whether it is hazardous or not before a disposal method can be determined.
- For disposal of hazardous waste, see WM-6, Hazardous Waste Management.
- If necessary, further treat liquid wastes prior to disposal. Treatment may include, though is not limited to, sedimentation, filtration, and chemical neutralization.

Costs

Prevention costs for liquid waste management are minimal. Costs increase if cleanup or fines are involved.

Inspection and Maintenance

- Inspect and verify that activity-based BMPs are in place prior to the commencement of associated activities. While activities associated with the BMP are under way, inspect weekly during the rainy season and of two-week intervals in the non-rainy season to verify continued BMP implementation.
- Inspect BMPs subject to non-stormwater discharge daily while non-stormwater discharges occur.

- Remove deposited solids in containment areas and capturing devices as needed and at the completion of the task. Dispose of any solids as described in WM-5, Solid Waste Management.
- Inspect containment areas and capturing devices and repair as needed.

References

Stormwater Quality Handbooks - Construction Site Best Management Practices (BMPs) Manual, State of California Department of Transportation (Caltrans), November 2000.

APPENDIX F: BMP INSPECTION FORM

BMP INSPECTION REPORT

Date and Time of Inspection:		Date Report Written:		
Inspection Type: (Circle one)	<i>Weekly Complete Parts I, II, III and VII</i>	<i>Pre-Storm Complete Parts I, II, III, IV and VII</i>	<i>During Rain Event Complete Parts I, II, III, V, and VII</i>	<i>Post-Storm Complete Parts I, II, III, VI and VII</i>
Part I. General Information				
Site Information				
Construction Site Name: CUSD District Office Expansion				
Construction stage and completed activities:			Approximate area of site that is exposed:	
Photos Taken: (Circle one)	Yes	No	Photo Reference IDs:	
Weather				
Estimate storm beginning: (date and time)		Estimate storm duration: (hours)		
Estimate time since last storm: (days or hours)		Rain gauge reading and location: (in)		
Is a "Qualifying Event" predicted or did one occur (i.e., 0.5" rain with 48-hrs or greater between events)? (Y/N) If yes, summarize forecast:				
Exemption Documentation (explanation required if inspection could not be conducted). Visual inspections are not required outside of business hours or during dangerous weather conditions such as flooding or electrical storms.				
Inspector Information				
Inspector Name:			Inspector Title:	
Signature:			Date:	

Part II. BMP Observations. Describe deficiencies in Part III.			
Minimum BMPs for Risk Level 1 Sites	Failures or other short comings (yes, no, N/A)	Action Required (yes/no)	Action Implemented (Date)
Good Housekeeping for Construction Materials			
Inventory of products (excluding materials designed to be outdoors)			
Stockpiled construction materials not actively in use are covered and bermed			
All chemicals are stored in watertight containers with appropriate secondary containment, or in a completely enclosed storage shed			
Construction materials are minimally exposed to precipitation			
BMPs preventing the off-site tracking of materials are implemented and properly effective			
Good Housekeeping for Waste Management			
Wash/rinse water and materials are prevented from being disposed into the storm drain system			
Portable toilets are contained to prevent discharges of waste			
Sanitation facilities are clean and with no apparent for leaks and spills			
Equipment is in place to cover waste disposal containers at the end of business day and during rain events			
Discharges from waste disposal containers are prevented from discharging to the storm drain system / receiving water			
Stockpiled waste material is securely protected from wind and rain if not actively in use			
Procedures are in place for addressing hazardous and non-hazardous spills			
Appropriate spill response personnel are assigned and trained			
Equipment and materials for cleanup of spills is available onsite			
Washout areas (e.g., concrete) are contained appropriately to prevent discharge or infiltration into the underlying soil			
Good Housekeeping for Vehicle Storage and Maintenance			
Measures are in place to prevent oil, grease, or fuel from leaking into the ground, storm drains, or surface waters			
All equipment or vehicles are fueled, maintained, and stored in a designated area with appropriate BMPs			
Vehicle and equipment leaks are cleaned immediately and disposed of properly			

Part II. BMP Observations Continued. Describe deficiencies in Part III.

Minimum BMPs for Risk Level 1 Sites	Adequately designed, implemented and effective (yes, no, N/A)	Action Required (yes/no)	Action Implemented (Date)
Good Housekeeping for Landscape Materials			
Stockpiled landscape materials such as mulches and topsoil are contained and covered when not actively in use			
Erodible landscape material has not been applied 2 days before a forecasted rain event or during an event			
Erodible landscape materials are applied at quantities and rates in accordance with manufacturer recommendations			
Bagged erodible landscape materials are stored on pallets and covered			
Good Housekeeping for Air Deposition of Site Materials			
Good housekeeping measures are implemented onsite to control the air deposition of site materials and from site operations			
Non-Stormwater Management			
Non-Stormwater discharges are properly controlled			
Vehicles are washed in a manner to prevent non-stormwater discharges to surface waters or drainage systems			
Streets are cleaned in a manner to prevent unauthorized non-stormwater discharges to surface waters or drainage systems.			
Erosion Controls			
Wind erosion controls are effectively implemented			
Effective soil cover is provided for disturbed areas inactive (i.e., not scheduled to be disturbed for 14 days) as well as finished slopes, open space, utility backfill, and completed lots			
The use of plastic materials is limited in cases when a more sustainable, environmentally friendly alternative exists.			
Sediment Controls			
Perimeter controls are established and effective at controlling erosion and sediment discharges from the site			
Entrances and exits are stabilized to control erosion and sediment discharges from the site			
Sediment basins are properly maintained			
Run-On and Run-Off Controls			
Run-on to the site is effectively managed and directed away from all disturbed areas.			
Other			
Are the project SWPPP and BMP plan up to date, available on-site and being properly implemented?			

Part III. Descriptions of BMP Deficiencies

Deficiency	Repairs Implemented: Note - Repairs must begin within 72 hours of identification and, complete repairs as soon as possible.	
	Start Date	Action
1.		
2.		
3.		
4.		

Part IV. Additional Pre-Storm Observations. Note the presence or absence of floating and suspended materials, sheen, discoloration, turbidity, odors, and source(s) of pollutants(s).

	Yes, No, N/A
Do stormwater storage and containment areas have adequate freeboard? If no, complete Part III.	
Are drainage areas free of spills, leaks, or uncontrolled pollutant sources? If no, complete Part VII and describe below.	
Notes:	
Are stormwater storage and containment areas free of leaks? If no, complete Parts III and/or VII and describe below.	
Notes:	

Part V. Additional During Storm Observations. If BMPs cannot be inspected during inclement weather, list the results of visual inspections at all relevant outfalls, discharge points, and downstream locations. Note odors or visible sheen on the surface of discharges. Complete Part VII (Corrective Actions) as needed.

Outfall, Discharge Point, or Other Downstream Location	
Location	Description
Location	Description
Location	Description
Location	Description
Location	Description
Location	Description
Location	Description
Location	Description

Part VI. Additional Post-Storm Observations. Visually observe (inspect) stormwater discharges at all discharge locations within two business days (48 hours) after each qualifying rain event, and observe (inspect) the discharge of stored or contained stormwater that is derived from and discharged subsequent to a qualifying rain event producing precipitation of ½ inch or more at the time of discharge. Complete Part VII (Corrective Actions) as needed.

Discharge Location, Storage or Containment Area	Visual Observation

Part VII. Additional Corrective Actions Required. Identify additional corrective actions not included with BMP Deficiencies (Part III) above. Note if SWPPP change is required.

Required Actions	Implementation Date

APPENDIX G: TRAINING REPORTING FORM

Identification of QSP

Project Name: CUSD District Office Expansion

WDID #: 5F10C401070

The following are QSPs associated with this project

Name of Personnel ⁽¹⁾	Company	Date

(1) If additional QSPs are required on the job site add additional lines and include information here

QSP Trained Delegate

Stormwater Management Training Log and Documentation

Project Name: CUSD District Office Expansion
WDID #: 5F10C401070

Stormwater Management Topic: (check as appropriate)

- | | |
|--|---|
| <input type="checkbox"/> Erosion Control | <input type="checkbox"/> Sediment Control |
| <input type="checkbox"/> Wind Erosion Control | <input type="checkbox"/> Tracking Control |
| <input type="checkbox"/> Non-Stormwater Management | <input type="checkbox"/> Waste Management and Materials Pollution Control |
| <input type="checkbox"/> Stormwater Sampling | |

Specific Training Objective: _____

Location: _____ Date: _____

Instructor: _____ Telephone: _____

Course Length (hours): _____

Attendee Roster (Attach additional forms if necessary)

Name	Company	Phone

As needed, add proof of external training (e.g., course completion certificates, credentials for QSP, QSD).

Trained Contractor Personnel Log

Stormwater Management Training Log and Documentation

Project Name: CUSD District Office Expansion
 WDID #: 5F10C401070

Stormwater Management Topic: (check as appropriate)

- | | |
|--|---|
| <input type="checkbox"/> Erosion Control | <input type="checkbox"/> Sediment Control |
| <input type="checkbox"/> Wind Erosion Control | <input type="checkbox"/> Tracking Control |
| <input type="checkbox"/> Non-Stormwater Management | <input type="checkbox"/> Waste Management and Materials Pollution Control |
| <input type="checkbox"/> Stormwater Sampling | |

Specific Training Objective: _____

Location: _____ Date: _____

Instructor: _____ Telephone: _____

Course Length (hours): _____

Attendee Roster (Attach additional forms if necessary)

Name	Company	Phone

As needed, add proof of external training (e.g., course completion certificates, credentials for QSP, QSD).

APPENDIX H: CONSTRUCTION GENERAL PERMIT

The State Water Resources Control Board National Pollutant Discharge Elimination System (NPDES) Construction General Permit, 2009-0009-DWQ as amended by 2010-0014-DWQ can be found at the following web site:

http://www.swrcb.ca.gov/water_issues/programs/stormwater/constpermits.shtml

Attachment C Risk Level 1 Requirements from the Construction General Permit can be reached through the hyperlink above.

APPENDIX I: AMENDMENT CERTIFICATION

SWPPP Amendment No. _____

Project Name: _____

Project Number: _____

**Qualified SWPPP Developer's Certification of the
Stormwater Pollution Prevention Plan Amendment**

“This Stormwater Pollution Prevention Plan and its appendices were prepared under my direction to meet the requirements of the California Construction General Permit (SWRCB Order No. 2009-009-DWQ as amended by 2010-0014-DWQ and 2012-0006-DWQ). I certify that I am a Qualified SWPPP Developer in good standing as of the date signed below.”

QSD's Signature

Date

QSD Name

QSD Certificate Number

Title and Affiliation

Telephone

Address

Email



Pre-bid RFI Log

Project name CUSD - District Office Expansion, Online School and Special Ed. Administration Office

Location 301 North Fowler Ave. Clovis, Ca, 93611

UPDATED 10/25/2023

RFI	Title	Issue/Question	Date	Plan/Spec Reference	Response
001	Baby changing station	The Following items are shown & not Specified. Please provide manufacturer & model #'s for pricing: Baby Changing Station-Shown on : Sheet #A914 IN Unisex room & A111 & Sheet#A952 Room B15	10/11/2023	102800-Toilet Accessories	Refer to Addendum 004 item 4-15
002	Carpet Tile Clarifications	Plans A900 call out for CPT 3, the Specifications only list CPT 1 and CPT 2. Please clarify what CPT 3 selection is to be. Also on Plan A940 it calls out CPT 2 however CPT 2 is a walk off product but the drawings have walk off as CPT M specific locations. Please clarify products to be used and if they will be OFCI.	10/11/2023	A900/A940	Refer to Addendum 005 item 5-39 & 5-55
003	Play area	Please provide the sand gravel thickness at the play area	10/11/2023	A110/A261	Refer to Addendum 003 item 3-08
004	Door Types	1) Door A06A is indicated to be a 45-minute rated HM-1 frame with a FG aluminum door. Please verify the door should be 'N' HM door. 2) Please verify doors A65B & A66B are HM doors installed in aluminum frames AH.	10/11/2023	A700	Refer to Addendum 003 item 3-19
005	Frame Indicators	Missing frame indicators on the floor plan: Please verify frame AM will be required for doors A72A, A82A, A36A, A37A, A43A, A45A, A46A, A48A, A51A, A52A, A53A, A54A, A59A, & A60A.	10/11/2023	A200	Refer to Addendum 003 item 3-06
006	Window AW	Please provide elevation, details, & specs for window AW.	10/11/2023	A200	Refer to Addendum 005 item 5-04
007	Casework Clarifications	1. What are the plastic laminate colors? 2. What are the solid surface colors? 3. Will A900/A940 be completed to show the counter colors? 4. What are the cabinets in A13 Workroom? Mail slots? Are they plastic laminate? A914/10	10/11/2023	A900/A940	Refer to Addendum 005 item 5-39 & 5-55

008	Window Flashing	<p>Please indicate material and finish for window flashing details: Page A810, detail 23 Page A820, detail 17 Page 823, detail 15</p> <p>Please indicate material for window flashing details: Page A820, details 7, 19 Page A821, details 7</p> <p>Please indicate finish for window flashing details: Page A820, details 9 Page 823, detail 12</p>	10/12/2023	Window Details	
009	Window Film	<p>Door Schedule, Remark C states, "Privacy film to glass, see specifications."</p> <p>1) Please provide specs and/or type of privacy film.</p> <p>2) Please verify that the door side lites and transom lites will require film too.</p>	10/12/2023	A700/A750 - Door Schedules	Refer to Addendum 003 item 3-19
010	Package DOE - 04 Sleeving	<p>Scope DOE – 04 – Building Steel & Fabrications / Metal Decking / Railings Under FOB Items #3</p> <p>States Furnish FOB jobsite all associated sleeves for fencing..</p> <p>Is this a mistake since fencing isn't in the scope?</p>	10/13/2023		See Revised S.O.W. in addendum 5-04
011	Cubicle Electrical Clarification	<p>Please clarify if the devices shown in the cubicle walls (Recepticles) will come pre-installed and wired for connection by Electrical or is the Electrical contractor to install.</p>	10/13/2023	E210/E220	Refer to Addendum 005 item 5-67 & 5-68
012	BLDG A Restroom Hot Water	<p>Please confirm Bathrooms A84 Unisex, A49 Unisex, A90 Girls, A91 Boys, A56 Girls and A57 Boys will not need hot water.</p>	10/16/2023	P200	Bid per plans and specs
013	Use of Cal Trans Oil Index	<p>We would like to ask that the District include the use of the Caltrans Oil Index for this project. The Oil Index protects the contractors and the owner from undue price increases or decreases.</p>	10/17/2023		Bid per plans and specs
014	Bldg B Roof Walk Pads	<p>Please confirm walkway mats overlapping with BLDG B valleys are to be cut.</p>	10/17/2023	A270	Refer to Addendum 003 item 3-10
015	Switchboard Bollards	<p>Please confirm if bollards are required at electrical switchboards.</p>	10/17/2023	A300/A350	Refer to Addendum 003 item 3-22

016	Perforated Fence Panels	Please clarify if this is a Door & Frame or a Perforated panel.	10/17/2023	A350 Elevation 4	Bid per plans and specs (Refer to 261 for additional information on the gates and panels)
017	Exterior Flatwork Clarification	Is 2" of sand required, vapor barrier to be placed above or below sand?	10/17/2023	A411	Refer to Addendum 003 item 3-11 thru 3-18
018	Termination Bar	Please confirm if PVC termination bar is required at 4'-0 above roof.	10/17/2023	A460 Detail 10	Bid per plans and specs
019	Canopy B-3 Dimension Clarification	There is conflicting dimension in Detail 10 and 20. Please provide correct dimension 42' 5 1/4" or 42' 4 7/8"?	10/17/2023	A654 Detail 10 & 20	Refer to Addendum 004 item 4-18
020	Curtain Wall Flashing	Is threshold flashing required @ curtain wall?	10/17/2023	A820 Detail 10	Refer to Addendum 005 item 5-36
021	Window Wall Cap	End wall cap to be required at windows?	10/17/2023	A822 Detail 22	Refer to Addendum 005 item 5-37
022	Soffit Framing Conflict	Detail 20 Conflicts with soffit framing, please advise.	10/17/2023	S006 Detail 20	Refer to Addendum 005 item 5-38
023	Canopy B-3 Attachment	What is the attachment to HSS?	10/17/2023	A896 Detail 3	Bid per plans and specs (3/A896 is for Architectural elements. Refer to Structural Plans for connection).
024	Threaded Rod @ Operable Panel Head	What are the dimensions for threaded rod - o.c.	10/17/2023	A831 Detail 3	Refer to Addendum 005 item 5-38
025	LVL at I Beam	Please confirm detail 15 A810 is correct for this condition	10/17/2023	A463	Bid per plans and specs (15/A810 is SIM for Architectural elements. Refer to Structural Plans for connection).

026	Interior Wall Tile Backer Board	<p>There are multiple details showing different tile backer boards. Detail 24 on A812 mentions both glass mat and cement board. Detail 20 on A821 shows cement board while detail 5 shows glass mat backer board.</p> <p>Specification 092900 2.4.A calls for Glass-Mat, Water-Resistant Backing Board.</p> <p>Please clarify correct backer board for wall tile installation on this project.</p>	10/19/2023	Gypsum Board 092900 A812 Detail 24 A821 Detail 05/20	Bid per plans and specs (Refer to details 10, 15, & 25/A840)
027	Track At Ceiling Attachment	<p>Per detail 3 on A870 suspended acoustical ceiling molding wall attachment is 24" oc max. Detail 23 on A870 states "TRACK @ CEILING ATTACHMENT."</p> <p>Per 24"oc max molding to wall attachment note, is track/backing per detail 23 necessary?</p> <p>If it is required, please clarify what type of backing and/or blocking detail is to be used. Or for potential cost savings is flat strap backing acceptable?</p>	10/19/2023	A870 Details 3/23	Bid per plans and specs
028	Bldg B Interior Elevation Line(s) Clarification	<p>There are multiple horizontal lines shown on A950 for Lobby Room B01 that do not have any call outs.</p> <p>Please clarify if horizontal lines shown are to be drywall alum. reveals sim. to Bldg. A note 9.22 on A910? If not, please identify what horizontal lines represent.</p> <p>See attached example for reference.</p>	10/19/2023	A950	Refer to Addendum 005 item 5-39 thru 5-64
029	Hand Dryer Substitution	Please advise if the attached Saniflow hand dryer substitution is acceptable.	10/19/2023		
030	Footing Elevation Clarifications	Sheet S003 details indicates "T.O. FTG PER PLAN," however, the plan does not show the elevation to the top of the FTG. Please advise.	10/20/2023	S003	Bid per plans and specs (Refer to S002 - Foundation Notes item 4)
031	DensGlass Sheathing Clarification	The plans call for 1/4" DensDeck Gypsum Sheathing at exterior walls over 1 1/2" Hat Channels. Spec section 061643 "Exterior Gypsum Sheathing" calls for Dens-Glass. Dens-Glass sheathing only comes in 1/2" and 5/8" thickness. Please advise	10/20/2023	A813 Detail 1	Bid per plans and specs
032	Access Controlled Door Clarification	On the door schedule pages (A700 and A750) there is a remark "B" the says, "Access Controlled Doors, see Electrical." This would indicate that the door hardware with the "B" should have some type of electrical component. The hardware groups for doors; A17A, A63B, A64B, A65A, A66A, B20A, B76A, and B78A do not have any type of electrical hardware to control. Please advise.	10/20/2023	Door Schedules A700/A750	Bid per plans and specs (Doors referenced do not require electronic componites but are monitored by Door Contacts).
033	Exterior Door B46A Clarification	Door #B46A is an exterior door that has the door type of "N" and frame type "HM-1." It appears that all the other exterior doors are storefront except this one. Should door #B46A be a storefront door?	10/20/2023	B46A	Bid per plans and specs

034	Operable Partition Substitution	Hufcor is listed as an acceptable manufacturer. We used to represent Hufcor, however, they are no longer fabricating operable partitions. We are now working with Corflex - a former Hufcor licensee so their products, track profiles etc are very similar. Please confirm that Corflex is an acceptable Manufacturer.	10/22/2023	10 22 38 Operable Partitions	
035	Operable Partition Clarifications	<p>1. Spec at 1.8 E states 'Buy American' - folding door to be manufactured in the United States. There is no reference in the overall Project Manual that this project has a Buy American requirement. Is 'Buy American' applicable?</p> <p>2. Spec at 2.3 - C5 calls out trimless panels. Corflex only offers panels with vertical panel edge trim - is this acceptable?</p> <p>3. Spec at 2.3 - C6 calls out SOSS hinges - this is a proprietary product from the Basis of Design and cannot be offered by any other operable partition manufacturer. Corflex offers Low profile piano hinges with projection of no more than 1/4" beyond panel faces - are these acceptable?</p> <p>4. Spec at 2.3 - F1 calls out roll-formed steel track, the Basis of Design's standard offering. Corflex's standard offering is clear anodized aluminum track - is this acceptable?</p>	10/22/2023	10 22 38 Operable Partitions	1. Refer to Addendum 005 item 5-03
036	Package DOE - 02 Gas Clarification	In bid package DOE-02 under the Gas it states to install protection bollards and pour slab for gas meter. I only see a fence around the gas meter which is typically the fence contractor. The bollards seem to only be around the transformer which isn't our work, and the slab is one solid slab for that whole yard not a separate one for the gas meter, typically the site concrete guys. This isn't usually in our bid items but do we need to bid this work on this job?	10/23/2023		See Revised S.O.W. in addendum 5-04
037	B01 Ceiling Clarification	<p>Lobby Room B01 on A650 notes exposed roof (no ceiling). Right next to "EXP" note, there is a GB-2 call out but nothing shown. There are also GB-2 call outs on interior elevations where RCP does not show any.</p> <p>Please clarify if GB-2 notes on RCP and interior elevations are misprints or if ceiling and/or soffits required that are not otherwise shown.</p>	10/23/2023	A650	Refer to Addendum 005 item 5-32 thru 5-35
038	Joist Ceiling Clarification	<p>Detail 3 on S008 is specifically only called out at Bldg A canopy framing for 8" metal stud joist ceilings (S700-26 & 27).</p> <p>None of the other canopy (3-5/8" 18g) stud joist ceilings specifically call this detail out.</p> <p>Please clarify if this blocking detail only applies to bldg A canopy noted on S700. If not, please provide locations where this detail is to be applied.</p>	10/23/2023	S700	Bid per plans and specs (The Joist Blocking of Detail 3/S008 shall occur on all CFS joists used for the Canopy Framing systems (A-1, A-3, A-4, A-6, A-9, B-1, B-2, B-3)).
039	Spacing Requirement	<p>Please clarify if there a spacing requirement for 1" strap bridging noted on detail 5 on S007?</p> <p>Or is this to be installed only at locations specifically called out or noted?</p>	10/23/2023	S007	Bid per plans and specs (The Cross Bridging of Detail 5/S007 occurs within 12" max of clip connection at each end of the CFS joists and shall occur continuously along the joist ends as shown in Details on S200 through S203).

040	Science Equipment MFR/Model Requested	Please call out Manufacturer and Model No. for items that are TBD on the Science Equipment Schedule at A211/22, as they are to be included under DOE-06 Casework summary of work.	10/23/2023	A211	Refer to Addendum 005 item 5-31
041	Fume Hood Clarifications	Please clarify the fume hood connections in stem lab A04 , both electrical and ventilation, are by others? Testing will be by others as well?	10/23/2023		See Revised S.O.W. in addendum 5-04
042	Plastic Laminate Edges	Reception A02 calls out plastic laminate counter tops A910/28 key note 6.32. details show bullnose self edge at counters. Plastic can not be formed with a radius both directions, this will need to be a square 1 ½" edge. This also occurred at B60. Please advise.	10/23/2023	A910/A861	Bid per plans and specs (refer to 064116 - 2.3 D 2a)
043	Duct Insulation	Duct Insulation: Does all rectangular ducts that require acoustic lining still require duct insulation wrap? Does the exposed spiral duct shown on the plans require duct insulation wrap?	10/23/2023		Bid per plans and specs (Refer to 230700 3.8 B)
044	Skilled & Trained	Will this project have any skilled labor requirements (Skilled and Trained Workforce)?	10/23/2023		There is no skilled & trained requirement
045	Ag Base @ Valley Gutters	Detail K on CX1.1 appears to have 6" Ag Base on top of 12" compacted soil similar to A/CX 1.1, do the valley gutters require ag base on top of soil?	10/23/2023	CX1.1 Detail K	Refer to Addendum 005 item 5-23
046	Concrete Adjacent to Valley Gutters	Arch. concrete adjacent to valley gutters @ street intersections inside the new construction area conflicts with civil regarding the width, please advise details to be used & if this concrete is to be heavy duty per A/CX 1.1	10/23/2023	C3.2/A101	Bid per plans and specs (A101 indicates location of Fire Access Lane minimum requirements).
047	Wall Stud Material Type	a. The Architectural Floor Plans (Ex: Building A: A201, A202 and Building B: A251, A252) reference 1-1/2"x7-1/4" LVL Wood Studs for various wall types b. Sheet S001 – General Structural Note – Sawn Lumber – Note 2 references for studs to be DF#1 c. Sheet S002 – Framing Notes – Note 6 states “See Architectural Drawings for Wall Stud Sizes and Spacing, UNO” QUESTION: Are all project wall studs to be Douglas Fir #1 per General Structural Note clarification (Ex: Sheet S001)? Or are we to use LVL studs where called out per Architectural Floor Plans (Ex: Wall Types 1,2,3/A201)? Please advise	10/24/2023	A201/S002	Bid per plans and specs (Refer to Architectural Plans for Material Type. Refer to S001 for Sawn Lumber and Structural Composite Lumber (LVL) for additional information).
048	Canopy Edge Detail Warranty	Please see the attached detail, the manufacturer cannot warranty this detail. I have included a rough sketch of an alternate detail that is warrantable. Please advise	10/24/2023		
049	HVAC Title 24	We have reviewed the Title 24 documents provided in the design drawings, along with any updates provided by addendum, and have not been able to locate the required section where it indicates “Systems to be Verified.” Please update the Title 24 documents to include the “Systems to be Verified” column noting the applicable systems.	10/24/2023		Refer to Addendum 005 item 5-66
050	Hand Dryer Clarification	Please clarify the hand dryer spec. In the division 10 spec, it mentions a semi-recessed dryer. The Xlerator is basis of design and it also mentions their recess kit part number. In the drawings under the Toilet Accessory Schedule, it clearly states “surface mounted”.	10/24/2023	102800 A951/A952	

051	Ornamental Fence	Ornamental Iron Fence spec calls for hot dipped galvanized and then powder coating. That is more expensive because of the hot dip after fabrication. Going with pregalvanized you get the 15 year warranty. Ameristar or Merchants are becoming the standard. Written specs call for 3" posts for the fence. Detail calls for 4" Fence detail shows no picket above the rail, Post detail shows picket going above rail.	10/24/2023	A111	
-----	------------------	--	------------	------	--

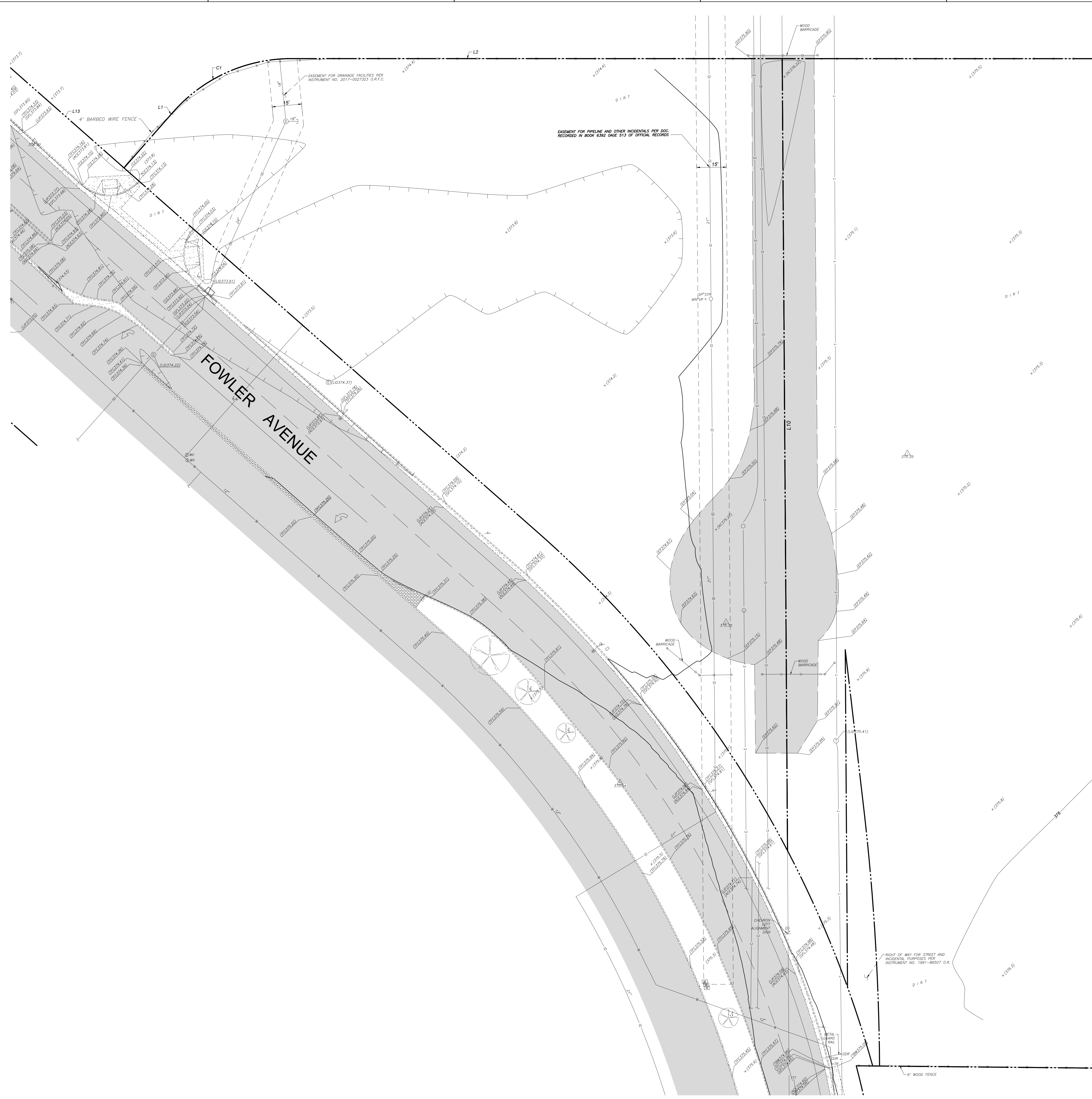

SEE SHEET C1.2 FOR CONTINUATION

REVISIONS			APPROVALS	
NO.	DATE	INITIAL	PROJECT ENGINEER	APPROVED (INITIAL)
			CONSTRUCTION MANAGEMENT	
			PLANNING/BUILDING	
			TRAFFIC	
			PARKS/REFUSE	
			UTILITIES/STREETS	
			CAPITAL PROJECTS	

SURVEY NOTES:

- THIS TOPOGRAPHIC SURVEY LOCATES SPECIFIC PHYSICAL FEATURES OF THE SITE AND THEIR ELEVATION AS DETERMINED NECESSARY BY THE PROJECT ENGINEER. IT IS NOT A COMPLETE TOPOGRAPHIC SURVEY OF THE SITE. THE INFORMATION SHOWN REFLECTS THE DATA OBTAINED BY FIELD SURVEY CONDUCTED ON FEBRUARY 16, 2022 AND FEBRUARY 17, 2022.
- UTILITY INFORMATION SHOWN HEREON IS BASED ON RECORD INFORMATION SUPPLIED TO THE ENGINEER BY UTILITY COMPANIES, PUBLIC AGENCIES AND THE PROPERTY OWNER, TOGETHER WITH OBSERVATION OF VISIBLE EVIDENCE BY A FIELD SURVEY. THE ENGINEER CAN MAKE NO GUARANTEE AS TO THE ACCURACY OR COMPLETENESS OF THE UNDERGROUND UTILITY FACILITIES SHOWN. PRIOR TO ANY SITE EXCAVATIONS, THE CONTRACTOR SHALL CONTACT THE OWNER AND UNDERGROUND SERVICE ALERT (USA) AND REQUEST THAT THEY IDENTIFY THE LOCATION OF ALL UNDERGROUND UTILITIES AT THE SITE.

SITE BENCHMARK:
 CITY OF CLOVIS BENCHMARK #125 IN CURB AT THE NORTHEAST CORNER OF HERNDON AND FOWLER 20' NORTH OF NORTH RETURN.
 ELEV = 376.730 NAVD83 DATUM

PROPERTY AND RW LINE AND CURVE TABLE							
NUMBER	LENGTH	RADIUS	LINE/CHORD BEARING	START NORTHING	START EASTING	END NORTHING	END EASTING
L10	402.220		S0° 08' 33"W	2188119.61	6362085.0	2187717.4	6362083.99
L3	535.398		N0° 08' 00"E	2188116.39	6362431.5	2188661.8	6362432.78
L2	273.538		N89° 28' 04"W	2188119.38	6362109.4	2188121.9	6361835.90
C1	67.967	80.00	S66° 16' 35"W	2188121.92	6361635.90	2188095.40	6361775.54
L1	37.839		S41° 49' 24"W	2188095.40	6361775.5	2188067.2	6361750.30
C3	100.132	562.00	N8° 54' 11"W	2187509.03	6362133.35	2187607.82	6362117.88
L12	8.354		S88° 55' 28"E	2187607.82	6362117.9	2187607.7	6362128.23
L7	750.552		S88° 55' 28"E	2187607.66	6362126.2	2187593.6	6362876.65
L4	670.999		N89° 28' 25"W	2188648.35	6362807.1	2188654.5	6362136.15
L5	670.999		N89° 28' 25"W	2188648.35	6362807.1	2188654.5	6362136.15
L8	320.310		S48° 05' 22"E	2188067.20	6361750.3	2187880.0	6361958.91
C2	324.067	562.00	N31° 34' 13"W	2187607.66	6362126.23	2187879.96	6361958.91
L6	1045.097		N0° 17' 50"E	2187593.58	6362876.6	2188838.7	6362882.07
L13	79.012		S48° 05' 22"E	2188119.98	6361691.5	2188067.2	6361750.30

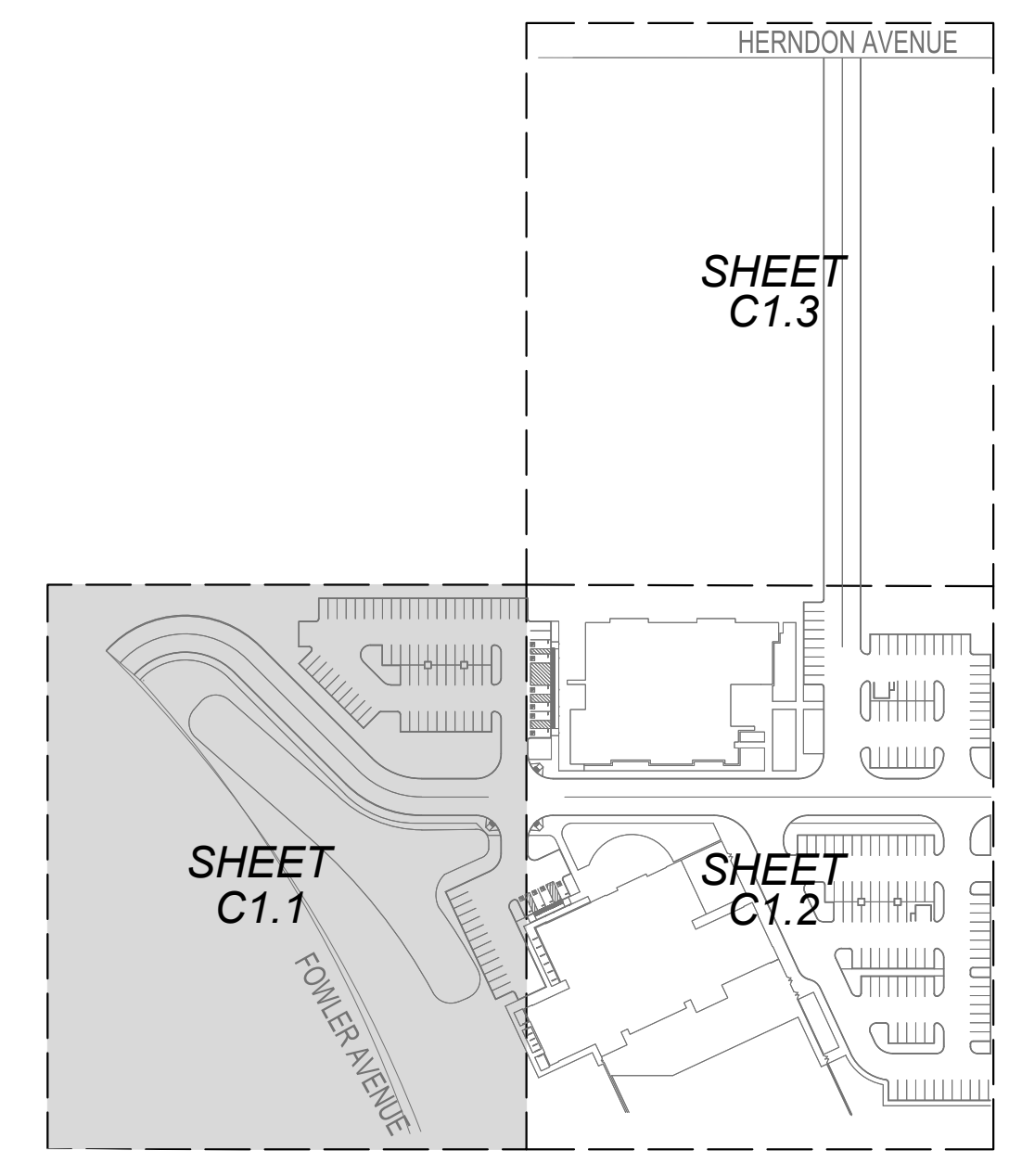
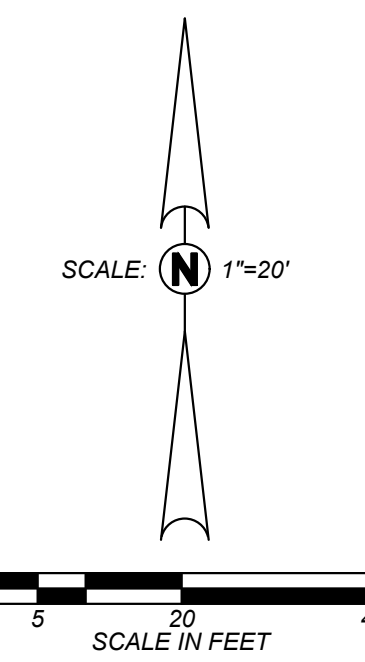

ONLINE SCHOOL & SPECIAL EDUCATION ADMINISTRATION DISTRICT OFFICE EXPANSION
CLOVIS UNIFIED SCHOOL DISTRICT
 CLOVIS, CA
 DRAWING TITLE
PARTIAL TOPOGRAPHIC SURVEY

PROJECT NO.
12242.00

DRAWING
C1.1

10/26/23 ADDENDUM 5

MARK	DATE	DESCRIPTION
	07/17/23	DSA BACKCHECK

TETER, LLP
 FRESNO HEADQUARTERS
 VISALIA | BAKERSFIELD | MADERA | SAN LUIS OBISPO
ARCHITECTS ENGINEERS CONNECTED

SEE SHEET C2.3 FOR CONTINUATION

SEE SHEET C2.1 FOR CONTINUATION

REVISIONS			APPROVALS	
NO.	DATE	INITIAL	APPROVED	(INITIAL)
			PROJECT ENGINEER	
			CONSTRUCTION MANAGEMENT	
			PLANNING/BUILDING	
			TRAFFIC	
			PARKS/REFUSE	
			UTILITIES/STREETS	
			CAPITAL PROJECTS	

DEMOLITION LEGEND:

- REMOVE EXISTING IMPROVEMENTS AS NECESSARY TO CONSTRUCT NEW IMPROVEMENTS SHOWN ON THESE PLANS UNLESS OTHERWISE NOTED ON THE PLAN. THE REMOVAL OF IMPROVEMENTS MUST BE COORDINATED WITH ALL PLAN SHEETS. CONTRACTOR MUST ALSO COORDINATE REMOVAL OF IMPROVEMENTS WITH UTILITY AGENCIES. PROTECT ALL IMPROVEMENTS NOT DESIGNATED FOR REMOVAL. SEE NOTE 1
- LIMITS OF VEGETATION REMOVAL. 4" MINIMUM DEPTH
- LIMITS OF CONCRETE IMPROVEMENT REMOVAL
- LIMITS OF ASPHALTIC CONCRETE IMPROVEMENT REMOVAL
- FRESNO IRRIGATION DISTRICT PIPELINE SHALL BE PROTECTED IN PLACE UNTIL NEW FID PIPE IS INSTALLED AND CONNECTED TO EXISTING AND APPROVAL TO DEMOLISH/ABANDON IN PLACE IS GIVEN BY FID. SEE SEPARATE SET OF PLANS FOR FID PIPELINE
- PROTECT ASPHALT CONCRETE PAVEMENT TO REMAIN
- PROTECT CONCRETE IMPROVEMENTS TO REMAIN
- PROTECT FENCE TO REMAIN
- PROTECT SIGN TO REMAIN
- PROTECT UTILITY TO REMAIN
- REMOVE ASPHALT CONCRETE PAVEMENT STRUCTURAL SECTION
- REMOVE WOOD BARRIER
- REMOVE CONCRETE IMPROVEMENTS
- REMOVE BARBED WIRE FENCE FABRIC, POSTS AND FOOTINGS
- REMOVE GUARDRAIL
- REMOVE UTILITY
- SAWCUT
- LIMIT OF CURB REMOVAL

GENERAL DEMOLITION NOTES:

1. THE "LIMIT OF DEMOLITION" SHOWN IS APPROXIMATE AND IS GENERALLY CONSIDERED TO BE THE MINIMUM REMOVAL REQUIREMENTS. CONTRACTOR MUST COORDINATE AS NOTED IN THE LEGEND.
2. CONTRACTOR SHALL LEGALLY DISPOSE OF ALL DEMOLISHED MATERIALS OFF SITE.
3. CONTRACTOR SHALL PROTECT ALL EXISTING UTILITY IMPROVEMENTS NOT SPECIFICALLY DESIGNATED FOR REMOVAL.
4. THE ON-SITE UNDERGROUND UTILITIES SHOWN ON THIS SHEET ARE AT APPROXIMATE LOCATIONS. THE EXTENT, LOCATIONS AND SIZES ARE UNKNOWN. THE CONTRACTOR SHALL POT-HOLE TO LOCATE AND VERIFY THE UNDERGROUND UTILITY LINES PRIOR TO REMOVAL.
5. CONTRACTOR TO PROTECT AND PRESERVE IN PLACE ANY FOUND SURVEY MONUMENTS. ANY MONUMENTS DISTURBED SHALL BE RESET BY A CALIFORNIA LICENSED SURVEYOR AND THE APPROPRIATE PAPERWORK FILED WITH THE CITY OR COUNTY, AT CONTRACTOR'S EXPENSE.
6. ALL HAZARDOUS MATERIALS ENCOUNTERED DURING SITE DEMOLITION SHALL BE REMEDIATED AND DISPOSED OF PER STATE AND EPA REQUIREMENTS.
7. CONTRACTOR SHALL CONTACT AND COORDINATE WITH ALL UTILITY AGENCIES PRIOR TO THE START OF ANY DEMOLITION OR CONSTRUCTION.
8. ANY EXISTING UTILITIES AND/OR IMPROVEMENTS WHICH ARE TO REMAIN, THAT BECOME DAMAGED DURING CONSTRUCTION SHALL BE COMPLETELY RESTORED TO THE SATISFACTION OF THE OWNER AND AGENCY HAVING AUTHORITY, AT THE CONTRACTOR'S SOLE EXPENSE.
9. REMOVE EXISTING IMPROVEMENTS AS NECESSARY TO CONSTRUCT NEW IMPROVEMENTS SHOWN ON THESE PLANS.
 - a) FOR CONCRETE REMOVAL, REMOVE TO THE NEXT NEAREST TOOLED JOINT OR EXPANSION JOINT OF IMPROVEMENTS DESIGNATED TO REMAIN.
 - b) FOR ASPHALTIC PAVEMENT REMOVAL, SAWCUT TO A STRAIGHT, CLEAN EDGE AT LOCATIONS INDICATED ON THE PLANS.
10. REFER TO MECHANICAL, ELECTRICAL, PLUMBING, IRRIGATION, AND ARCHITECTURAL PLANS FOR ADDITIONAL DEMOLITION AND COORDINATION.
11. COMPLIANCE WITH FIRE SAFETY DURING CONSTRUCTION WILL BE ENFORCED.

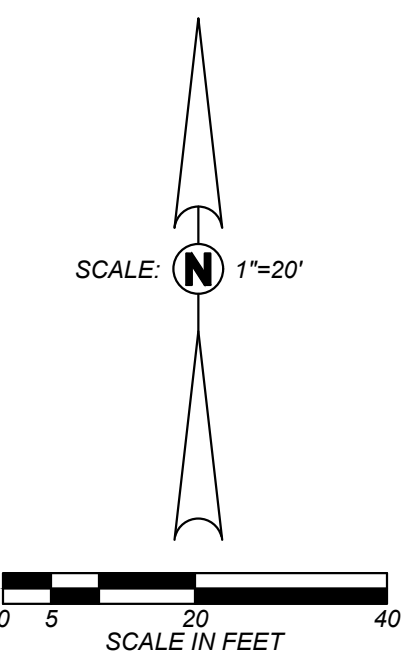
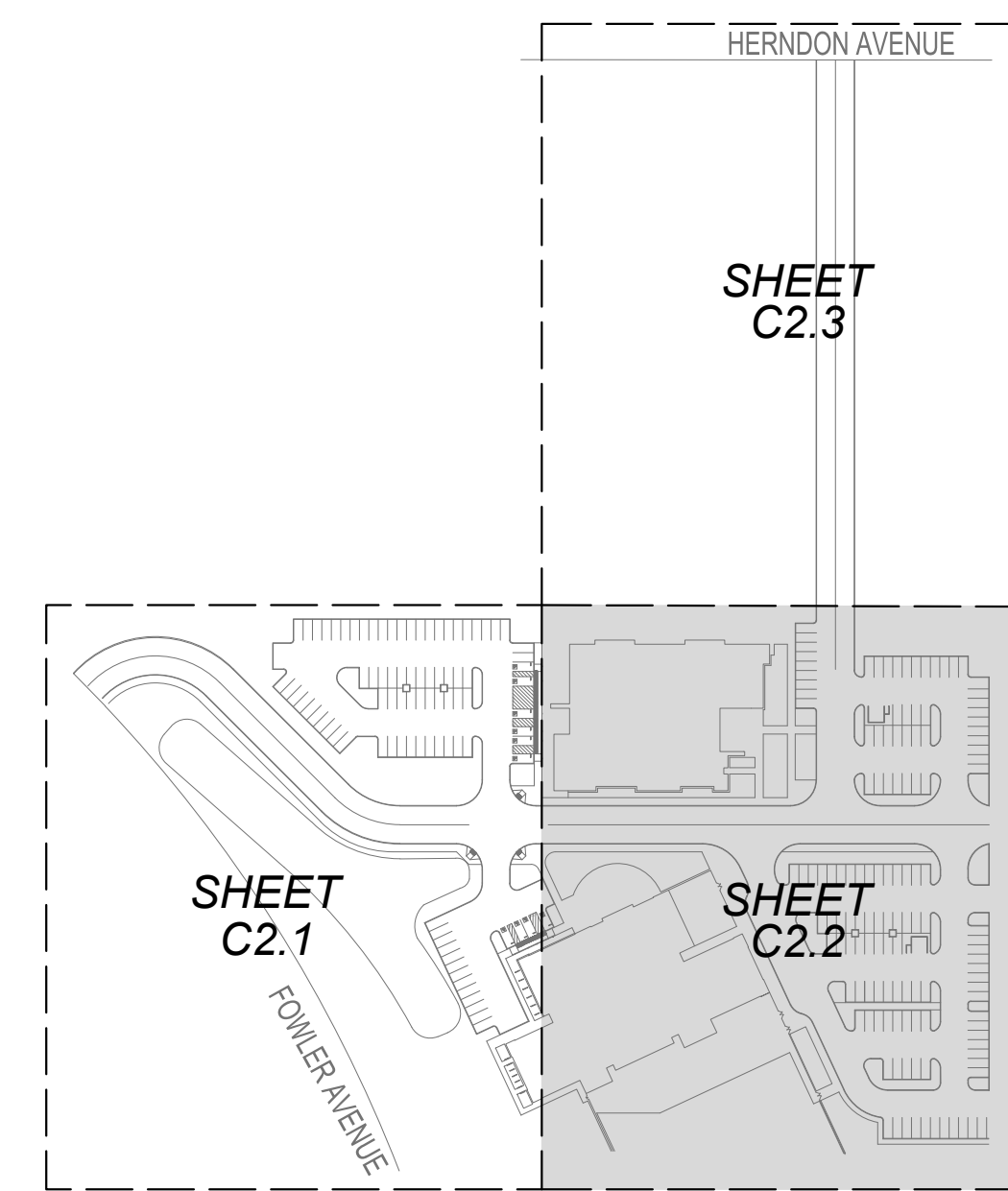

Blair, Church & Flynn
CONSULTING ENGINEERS
481 Clark Avenue, Suite 200
Clovis, California 95312
Tel (509) 328-1400
Fax (509) 328-1800

12/12/2022
Date signed: [Signature]

MARK	DATE	DESCRIPTION	DSA BACKCHECK
A	10/26/23	ADDENDUM 5	07/17/23

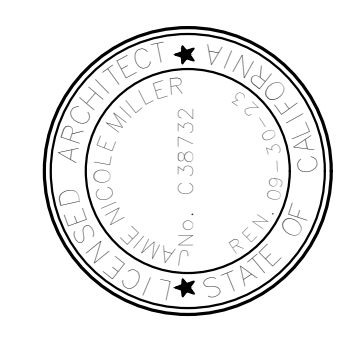

TETER, LLP
FRESNO HEADQUARTERS
VISALIA | BAKERSFIELD | MADERA | SAN LUIS OBISPO
ARCHITECTS ENGINEERS CONNECTED

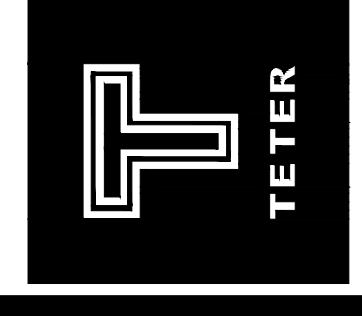

ONLINE SCHOOL & SPECIAL EDUCATION
ADMINISTRATION DISTRICT OFFICE EXPANSION
CLOVIS UNIFIED SCHOOL DISTRICT
CLOVIS, CA
DRAWING TITLE
PARTIAL DEMOLITION PLAN

PROJECT NO.
12242.00
DRAWING
C2.2

HERNDON AVENUE

REVISIONS			APPROVALS		
NO.	DATE	INITIAL	PROJECT ENGINEER	CONSTRUCTION MANAGEMENT	PLANNING/BUILDING

SITE LEGEND:

- LIMITS OF CONCRETE IMPROVEMENTS
- LIMITS OF HEAVY DUTY CONCRETE IMPROVEMENTS PER [A/CX1.1]
- LIMITS OF REGULAR DUTY ASPHALTIC CONCRETE PAVEMENT STRUCTURAL SECTION PER [B/CX1.1]
- LIMITS OF HEAVY DUTY ASPHALTIC CONCRETE PAVEMENT STRUCTURAL SECTION PER [B/CX1.1]
- DETECTABLE WARNINGS PER [E/CX1.2]
- CHAIN LINK FENCE, SEE ARCHITECTURAL
- DECORATIVE METAL FENCE, SEE ARCHITECTURAL
- POLE MOUNTED LIGHT FIXTURE, SEE ELECTRICAL
- PROTECTION BOLLARD PER DETAIL [A/CX2.2]
- PG&E METAL BARRIER POST, SEE ARCHITECTURAL
- FLAGPOLE, SEE ARCHITECTURAL
- LIMITS OF PAINTED CURB
- PLANTER
- CONCRETE CURB PER [F/CX1.1]
- CONCRETE SIDEWALK PER [A/CX1.1]
- PARALLEL CURB RAMP PER [D/CX1.2]
- FLARED CONCRETE CURB RAMP PER [G/CX1.2]
- CONCRETE MOWSTRIP PER [E/CX1.1]
- CONCRETE CURB AND GUTTER PER [C/CX1.1]
- REINFORCED CONCRETE VALLEY GUTTER PER [K/CX1.1]
- CONCRETE WHEELSTOP PER [F/CX1.2]
- PAINT 4" WIDE WHITE BORDER WITH 4" WIDE WHITE DIAGONAL LINES AT 3" ON CENTER
- PAINT DIRECTION ARROW WHITE PER [I/CX1.1]
- PAINT 4" WIDE WHITE LINE
- ACCESSIBLE PARKING STALLS, SEE [A/CX1.2] FOR ALL ACCESS REQUIREMENTS
- ACCESSIBLE PARKING STALL SIGNAGE PER [C/CX1.2]
- PAINT TOP AND FACE OF CURB RED WITH 4" HIGH LETTERING, "NO PARKING - FIRE LANE" AT 30" MAX. ON CENTER ON FACE OF CURB
- DECORATIVE METAL FENCE, SEE ARCHITECTURAL
- ENTRY WARNING SIGN PER [H/CX1.2]
- CITY OF CLOVIS TYPE IV TRASH ENCLOSURE, SEE ARCHITECTURAL & STRUCTURAL DRAWINGS
- CHANNEL GUTTER SECTION PER [J/CX1.1]
- MEDIAN ISLAND CURB PER CITY STD. DWG. ST-25
- CURB RAMP PER CITY STD. DWG. ST-11
- CONCRETE SIDEWALK PER CITY STD. DWG ST-5, CURB AND GUTTER PER CITY STD. DWG ST-5 WHERE SHOWN ON PLANS
- VALLEY GUTTER PER CITY STD. DWG. ST-10
- ASPHALTIC CONCRETE PAVEMENT PLUG PER CITY STD. ST-20
- PAINT 36" TALL 'STOP' PER CALTRANS STD. A24D
- STOP SIGN PER DETAIL [L/CX1.1]
- PAINT 12" HIGH WHITE LETTERING AS SHOWN ON PLANS
- PAINT 12" WIDE WHITE STRIPE
- PAINT TOP AND FACE OF CURB GREEN WITH 4" HIGH LETTERING, "LOADING ZONE - NO PARKING" AT 15" MAX. ON CENTER ON FACE OF CURB
- TEMPORARY TIMBER BARRICADE PER CITY STD. DWG. ST-13
- CONCRETE SEAT WALL PER [D/CX1.1]
- BLUE REFLECTOR FIRE HYDRANT MARKER PER CITY OF CLOVIS STANDARD W-2
- PEDESTRIAN CROSSING SIGN PER [M/CX1.1]
- CMU WALL, SEE STRUCTURAL
- DRIVEWAY APPROACH PER CITY STD. ST-7
- REDWOOD HEADER BOARD PER [N/CX1.1]

SEE SHEET C3.1 FOR GENERAL SITE NOTES

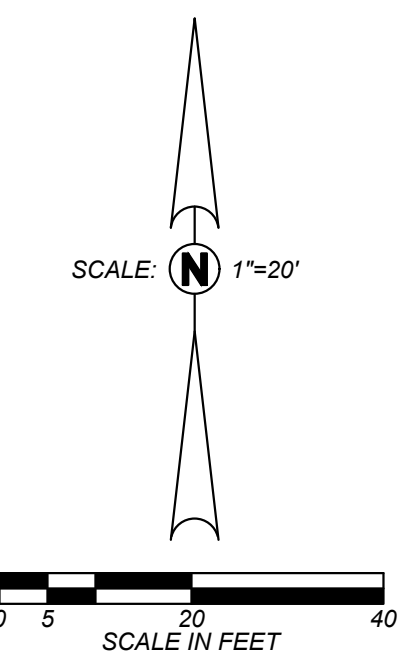
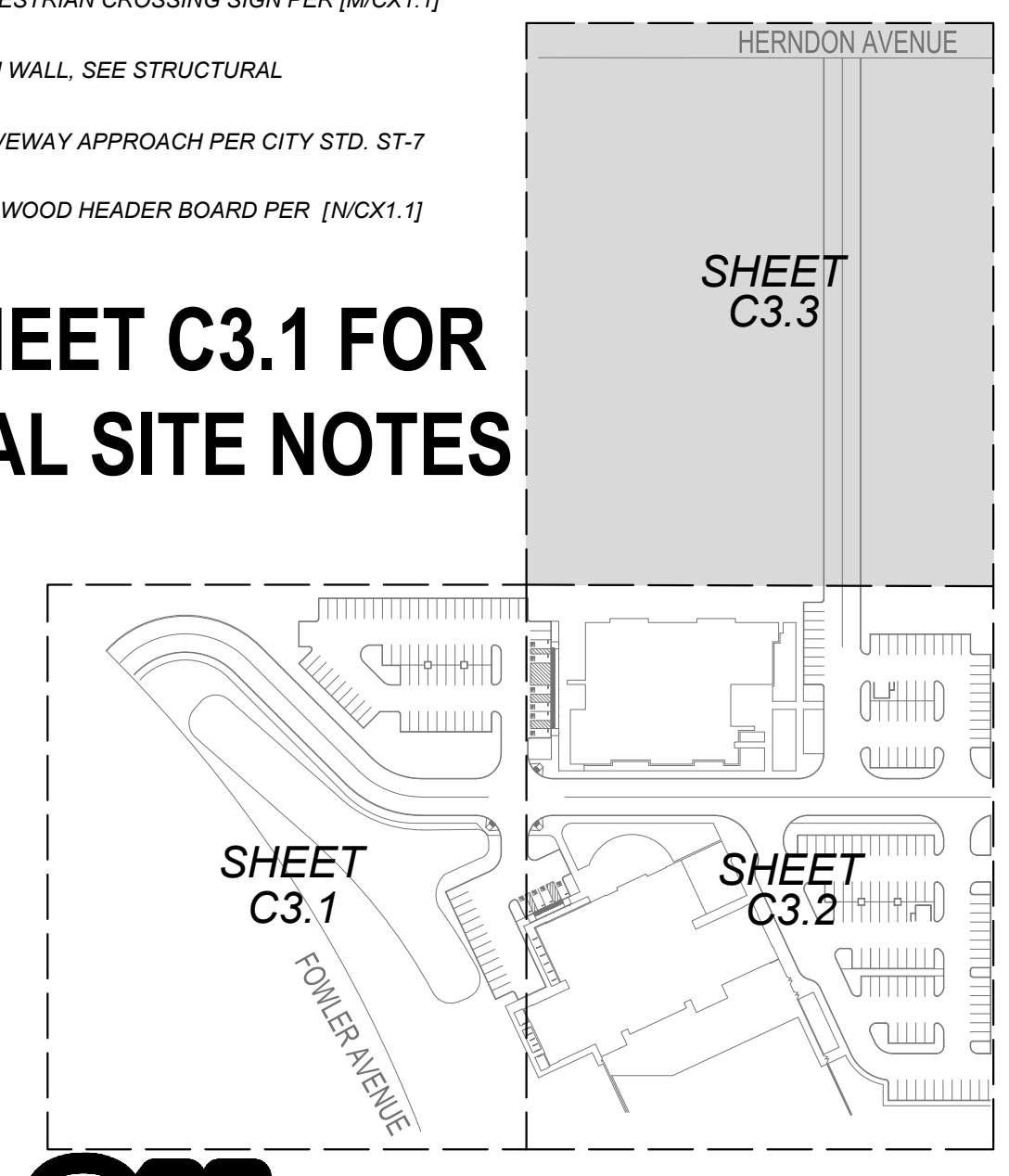

Blair, Church & Flynn
CONSULTING ENGINEERS
481 Clovis Avenue, Suite 200
Clovis, California 93612
Tel (559) 328-1400
Fax (559) 328-1800
Date signed: 12/12/2022

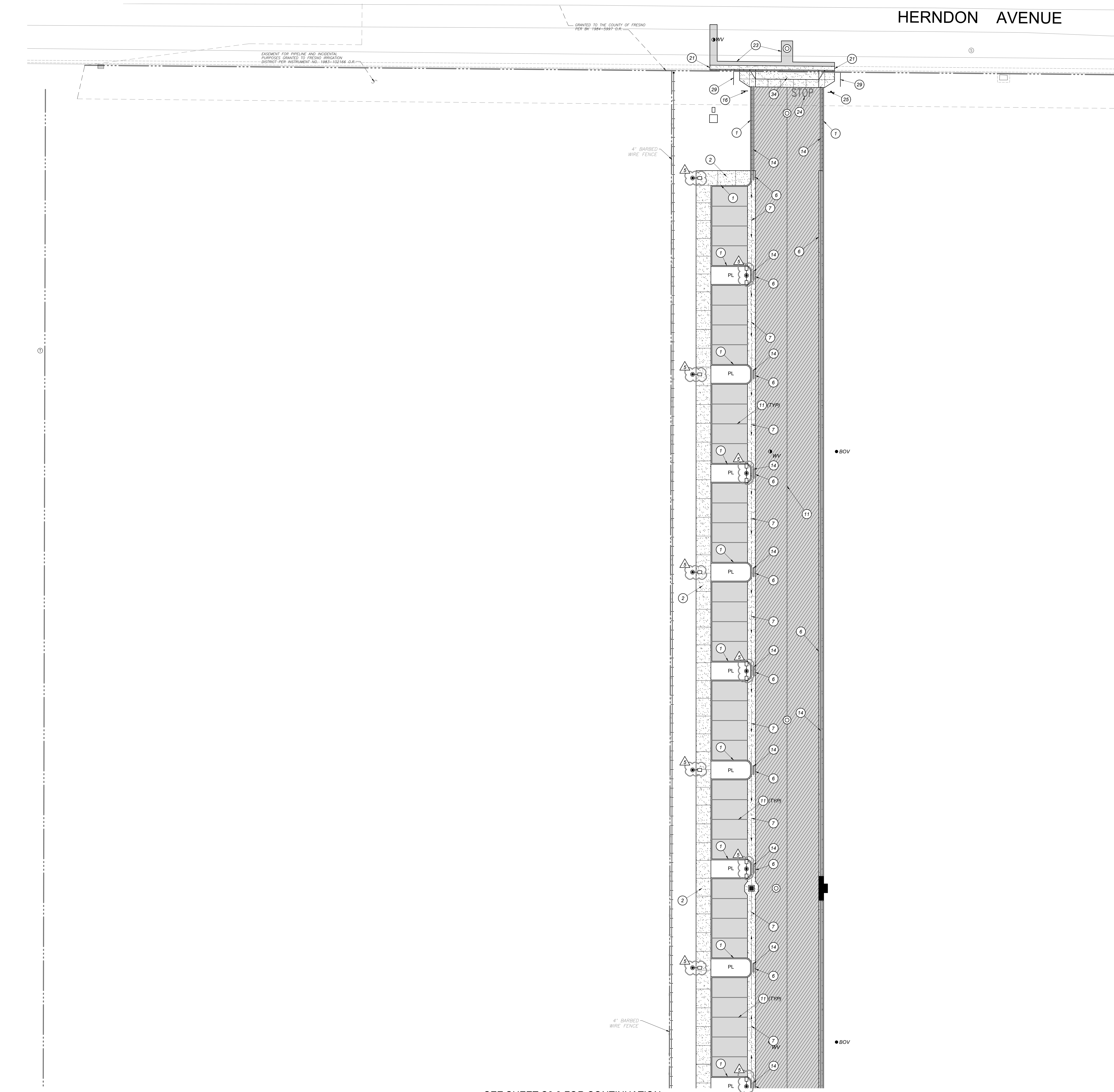

SEE SHEET C3.2 FOR CONTINUATION

MARK	DATE	DESCRIPTION	DSR BACKCHECK

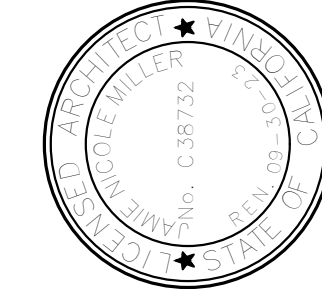

TETER, LLP
FRESNO HEADQUARTERS
VISALIA | BAKERSFIELD | MADERA | SAN LUIS OBISPO
ARCHITECTS ENGINEERS CONNECTED

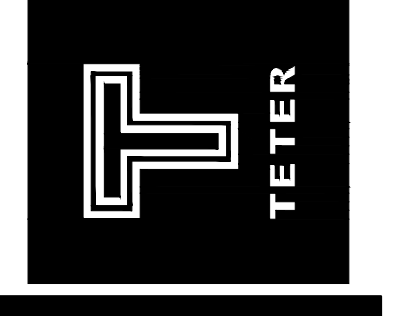

ONLINE SCHOOL & SPECIAL EDUCATION
ADMINISTRATION DISTRICT OFFICE EXPANSION
CLOVIS UNIFIED SCHOOL DISTRICT
CLOVIS, CA
DRAWING TITLE
PARTIAL SITE PLAN

PROJECT NO.
12242.00
DRAWING
C3.3

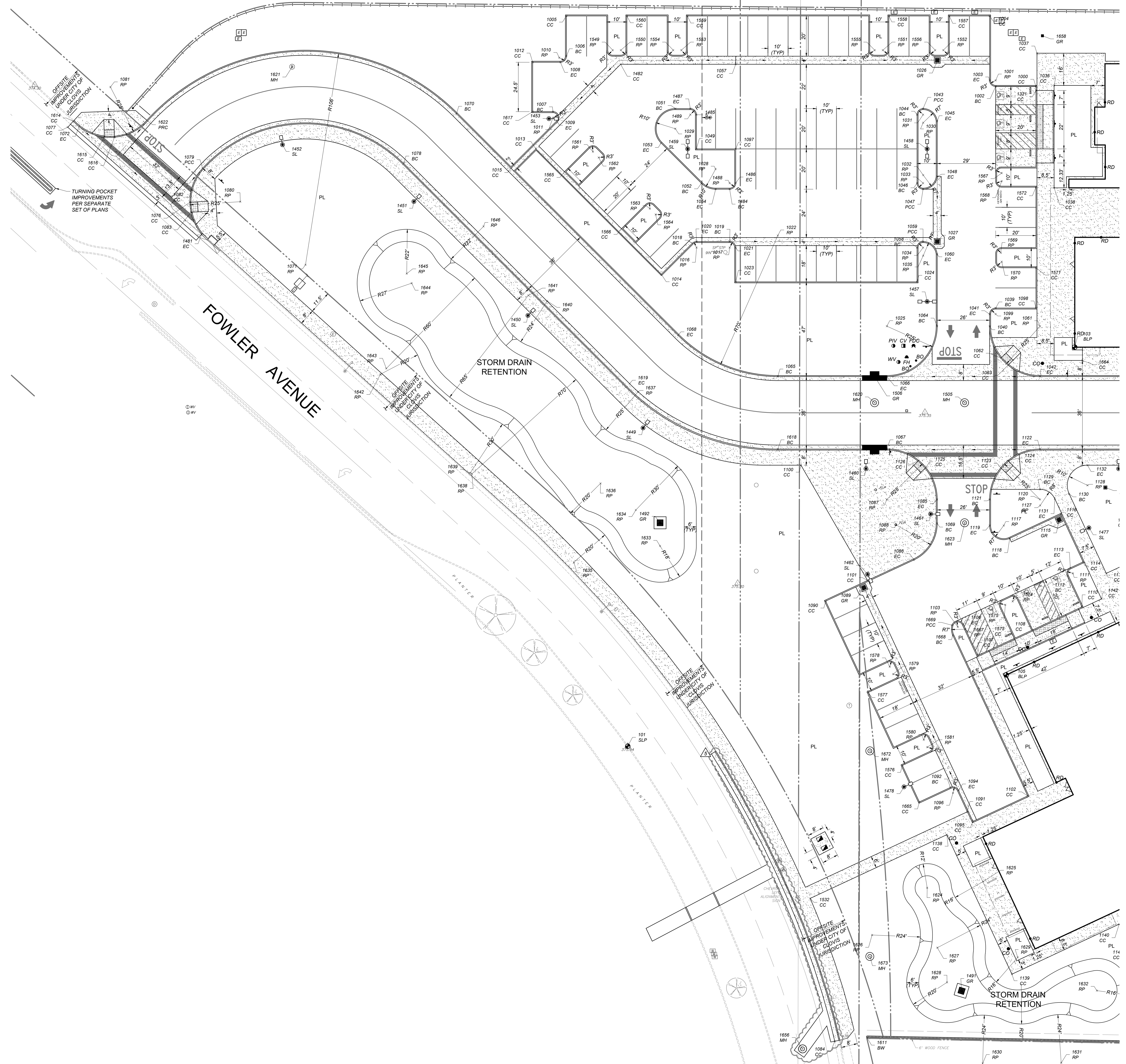

SEE SHEET C4.2 FOR CONTINUATION

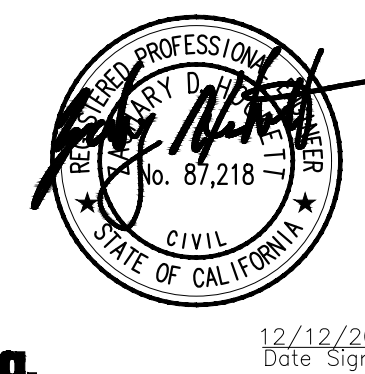
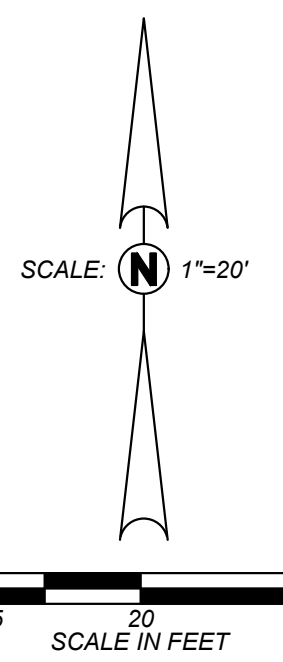

Blair Church & Flynn
CONSULTING ENGINEERS
481 Clovis Avenue, Suite 200
Clovis, California 93225
Tel: (559) 326-1400
Fax: (559) 326-1800

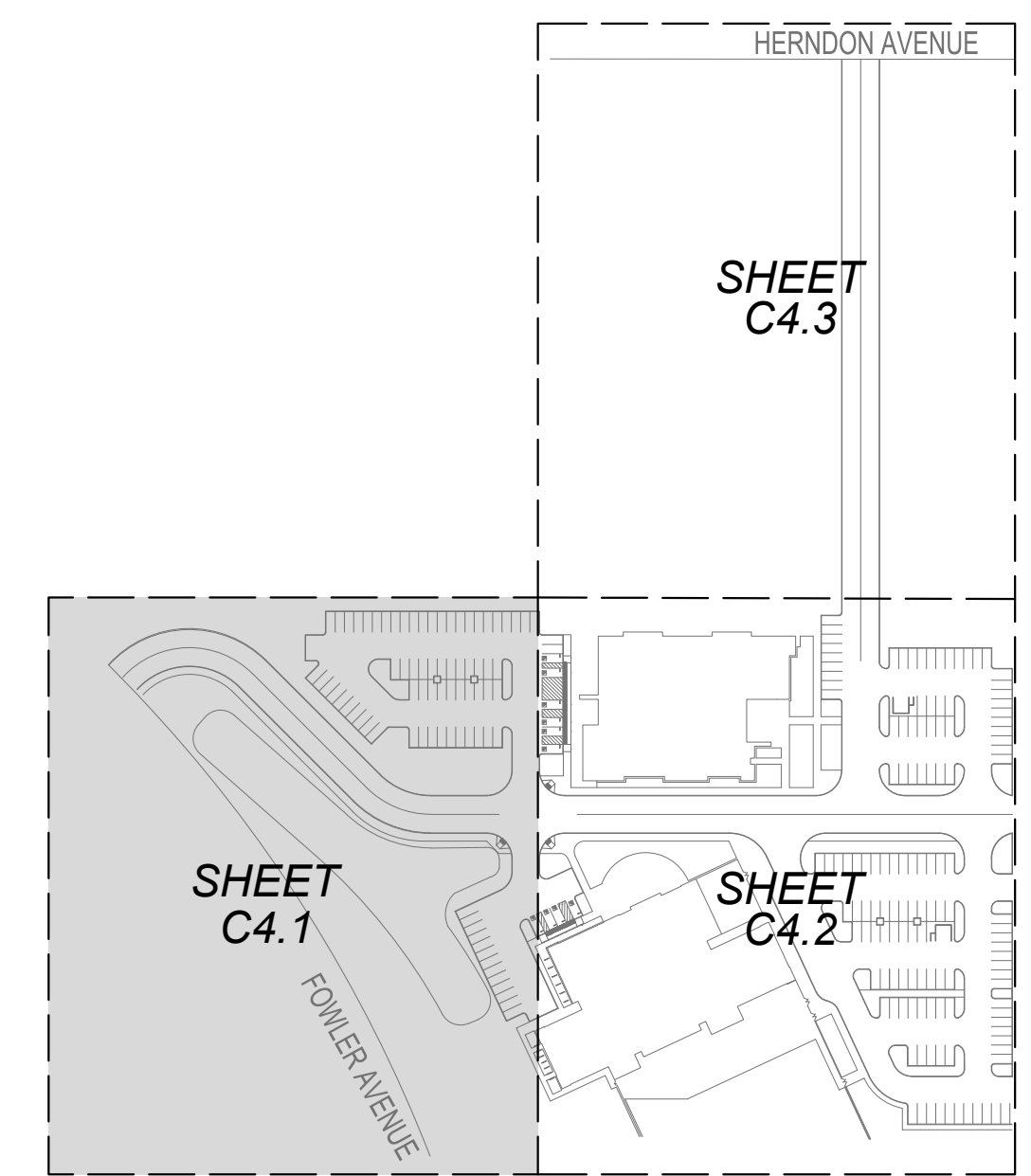

REVISIONS			APPROVALS	
NO.	DATE	INITIAL	PROJECT ENGINEER	APPROVED (INITIAL)
			CONSTRUCTION MANAGEMENT	
			PLANNING/BUILDING	
			TRAFFIC	
			PARKS/REFUSE	
			UTILITIES/STREETS	
			CAPITAL PROJECTS	

- GENERAL HORIZONTAL CONTROL NOTES:**
- ALIGNMENT OF THE SITE LAYOUT GRID IS BASED ON AN ASSUMED COORDINATE SYSTEM.
 - SITE LAYOUT POINT 100 IS CITY OF CLOVIS BENCHMARK #125 IN CURB AT THE CORNER OF HERNDON AND FOWLER 20' NORTH OF NORTH RETURN.
 - SITE LAYOUT POINT 101 IS A CHISELED X LOCATED IN THE MEDIAN ISLAND CURB ON FOWLER AVENUE APPROXIMATELY 193' NORTH WEST OF THE SOUTH WEST PROPERTY LINE.
 - SITE LAYOUT POINT 102 IS SPIKE LOCATED APPROXIMATELY 240' EAST OF THE NORTH WEST PROPERTY LINE ON HERNDON AVENUE.
 - DIMENSIONS AND POINTS ARE TO CENTER OF FENCE POSTS, FACE OF BUILDINGS, TOP FACE OF CURB, OR EDGE OF CONCRETE, UNLESS SHOWN OTHERWISE.

- HORIZONTAL CONTROL LEGEND:**
- 100 LCP LAYOUT COORDINATE POINT
 - 100 SLP SITE LAYOUT POINT
 - 100 BLP BUILDING LAYOUT POINT
 - BC BEGIN OF CURVE
 - BW BLOCK WALL
 - CC CORNER CONCRETE
 - EC END OF CURVE
 - FP FENCE POST
 - GR DRAIN INLET GRATE
 - MH MANHOLE
 - PPC POINT OF COMPOUND CURVE
 - PRC POINT OF REVERSE CURVE
 - RP RADIUS POINT
 - SL SITE LIGHT POLE

MARK	DATE	DESCRIPTION	DSA BACKCHECK

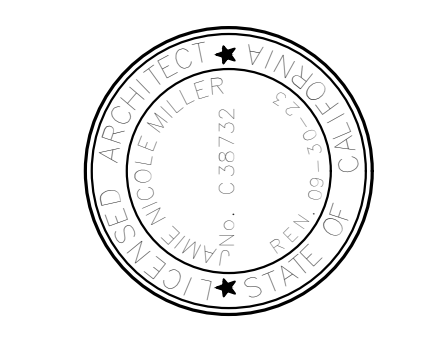

TETER, LLP
FRESNO HEADQUARTERS
VISALIA | BAKERSFIELD | MADERA | SAN LUIS OBISPO
ARCHITECTS ENGINEERS CONNECTED

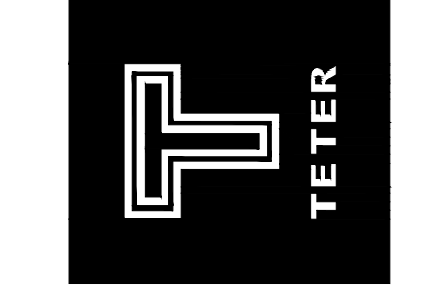

ONLINE SCHOOL & SPECIAL EDUCATION ADMINISTRATION DISTRICT OFFICE EXPANSION
CLOVIS UNIFIED SCHOOL DISTRICT
CLOVIS, CA
DRAWING TITLE
PARTIAL HORIZONTAL CONTROL PLAN

PROJECT NO.
12242.00
DRAWING
C4.1

REVISIONS		APPROVALS	
NO.	DATE	INITIAL	APPROVED (INITIAL)

- GENERAL HORIZONTAL CONTROL NOTES:**
- ALIGNMENT OF THE SITE LAYOUT GRID IS BASED ON AN ASSUMED COORDINATE SYSTEM.
 - SITE LAYOUT POINT 100 IS CITY OF CLOVIS BENCHMARK #125 IN CURB AT THE CORNER OF HERNDON AND FOWLER 20' NORTH OF NORTH RETURN.
 - SITE LAYOUT POINT 101 IS A CHISELED X LOCATED IN THE MEDIAN ISLAND CURB ON FOWLER AVENUE APPROXIMATELY 193' NORTH WEST OF THE SOUTH WEST PROPERTY LINE.
 - SITE LAYOUT POINT 102 IS SPIKE LOCATED APPROXIMATELY 240' EAST OF THE NORTH WEST PROPERTY LINE ON HERNDON AVENUE.
 - DIMENSIONS AND POINTS ARE TO CENTER OF FENCE POSTS, FACE OF BUILDINGS, TOP FACE OF CURB, OR EDGE OF CONCRETE, UNLESS SHOWN OTHERWISE.

HORIZONTAL CONTROL LEGEND:

	LAYOUT COORDINATE POINT
	SITE LAYOUT POINT
	BUILDING LAYOUT POINT
	BEGIN OF CURVE
	BLOCK WALL
	CORNER CONCRETE
	END OF CURVE
	FENCE POST
	DRAIN INLET GRATE
	MANHOLE
	POINT OF COMPOUND CURVE
	POINT OF REVERSE CURVE
	RADIUS POINT
	SITE LIGHT POLE

MARK	DATE	DESCRIPTION	DSA BACKCHECK

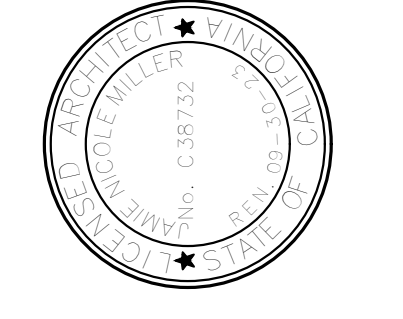

TETER, LLP
 FRESNO HEADQUARTERS
 VISALIA | BAKERSFIELD | MADERA | SAN LUIS OBISPO
ARCHITECTS ENGINEERS CONNECTED

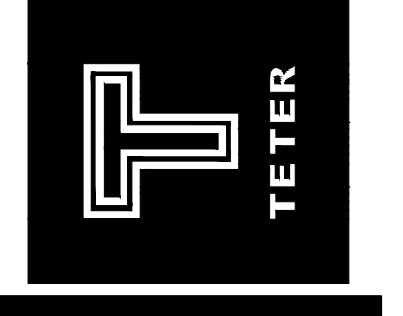

ONLINE SCHOOL & SPECIAL EDUCATION ADMINISTRATION DISTRICT OFFICE EXPANSION
 CLOVIS, CA
CLOVIS UNIFIED SCHOOL DISTRICT
 DRAWING TITLE
PARTIAL HORIZONTAL CONTROL PLAN

PROJECT NO.
12242.00
 DRAWING
C4.2

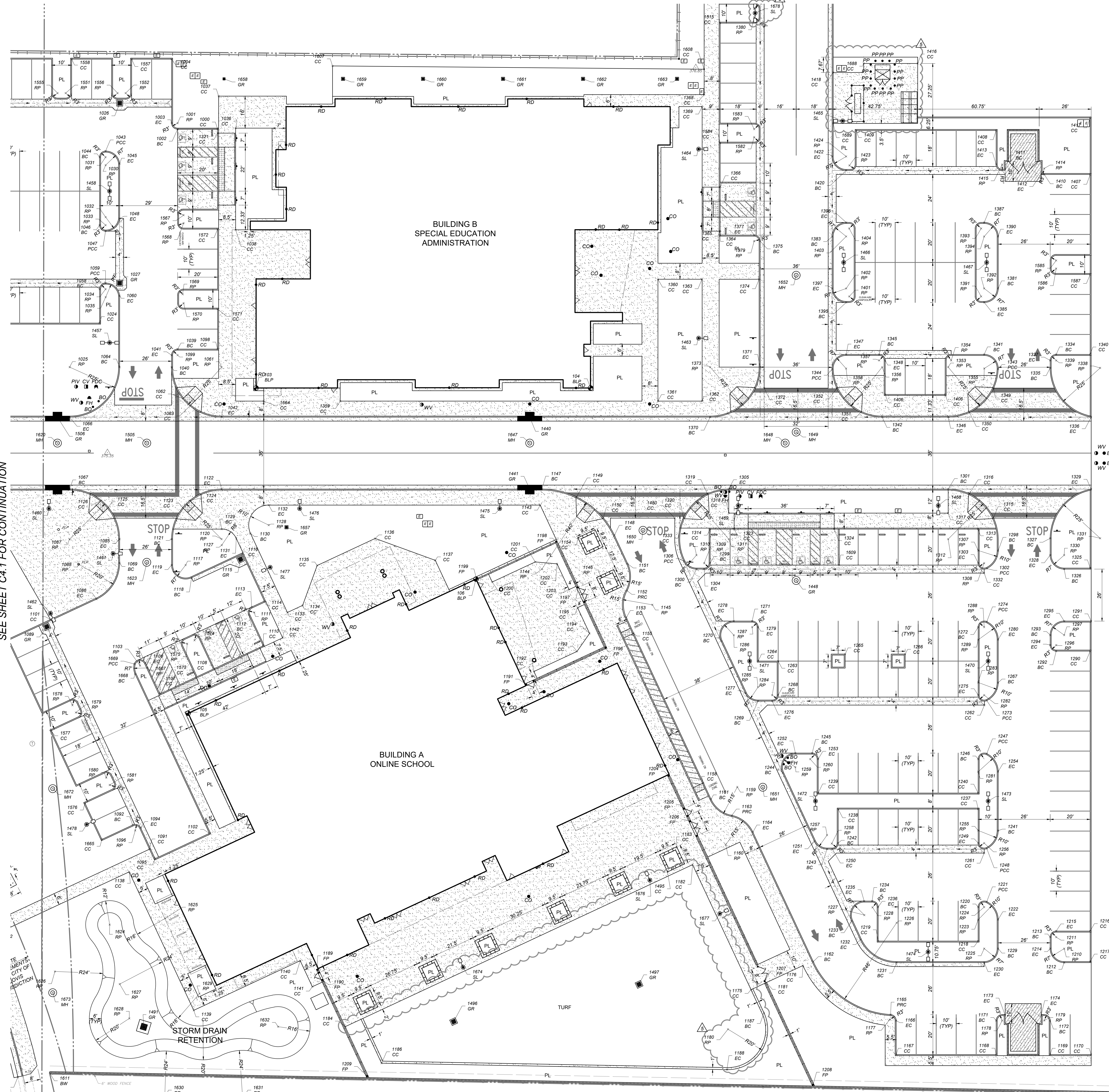

SEE SHEET C4.1 FOR CONTINUATION

SEE SHEET C4.4 FOR CONTINUATION

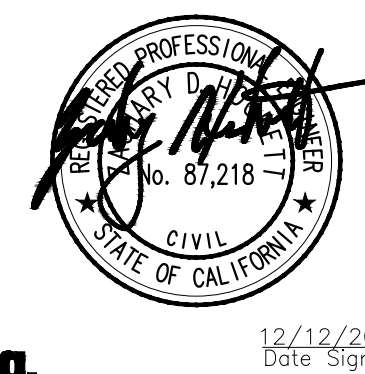
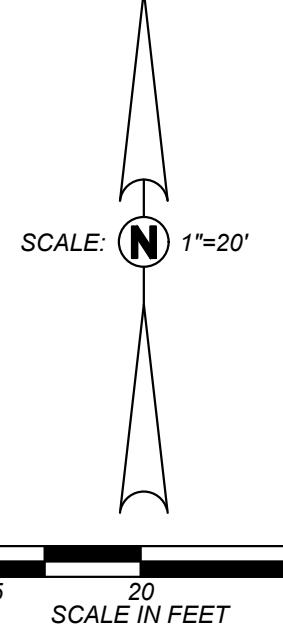
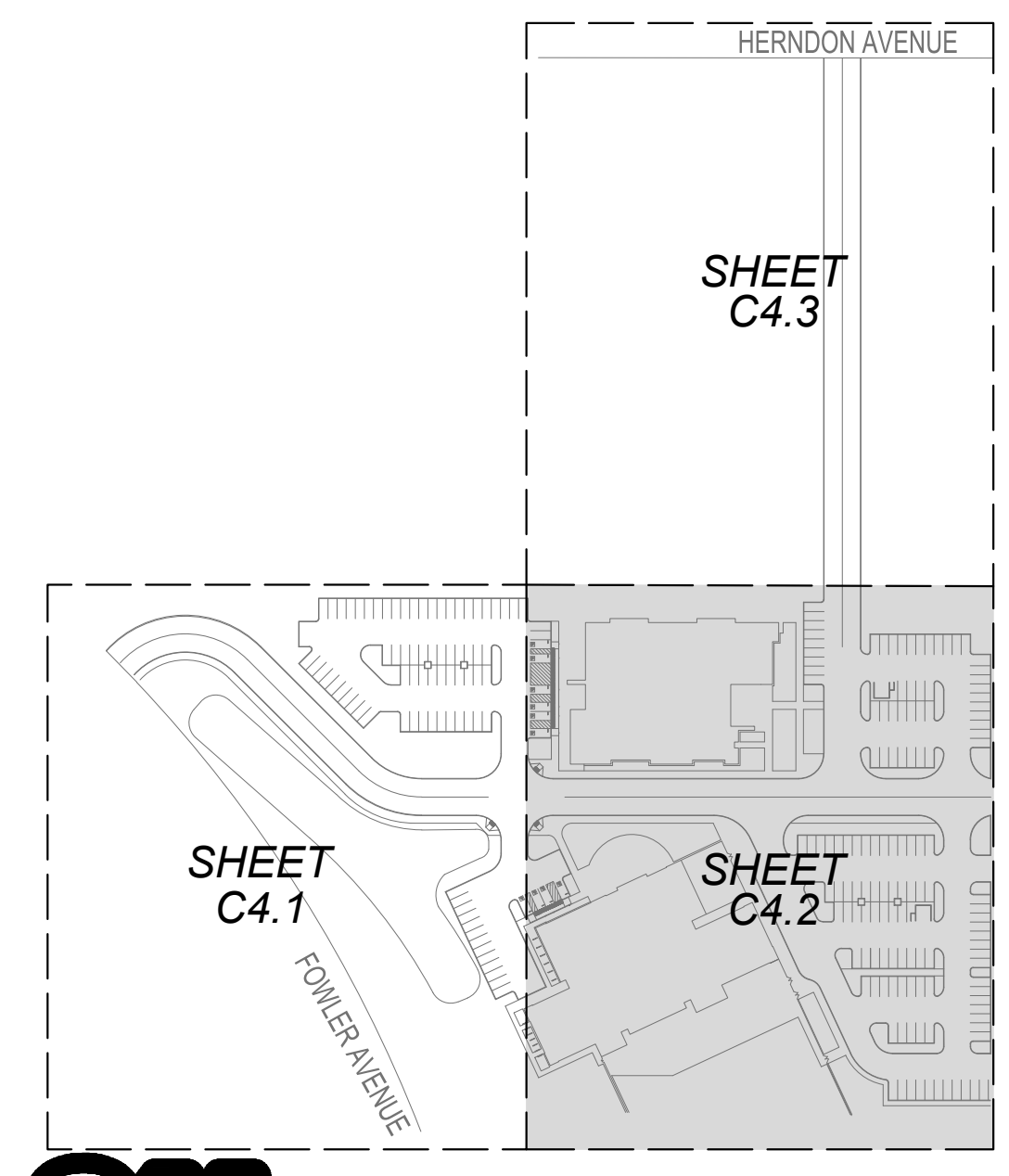

Blair, Church & Flynn
 CONSULTING ENGINEERS
 481 Clark Avenue, Suite 200
 Clovis, California 93212
 Tel: (509) 326-1400
 Fax: (509) 326-1500

HERNDON AVENUE

REVISIONS			APPROVALS		
NO.	DATE	INITIAL	APPROVED	INITIAL	
△			PROJECT ENGINEER		NA
△			CONSTRUCTION MANAGEMENT		NA
△			PLANNING/BUILDING		NA
△			TRAFFIC		NA
△			PARKS/REFUSE		NA
△			UTILITIES/STREETS		NA
△			CAPITAL PROJECTS		NA

GENERAL HORIZONTAL CONTROL NOTES:

- ALIGNMENT OF THE SITE LAYOUT GRID IS BASED ON AN ASSUMED COORDINATE SYSTEM.
- SITE LAYOUT POINT 100 IS CITY OF CLOVIS BENCHMARK #125 IN CURB AT THE CORNER OF HERNDON AND FOWLER 20' NORTH OF NORTH RETURN.
- SITE LAYOUT POINT 101 IS A CHISELED X LOCATED IN THE MEDIAN ISLAND CURB ON FOWLER AVENUE APPROXIMATELY 193' NORTH WEST OF THE SOUTH WEST PROPERTY LINE.
- SITE LAYOUT POINT 102 IS SPIKE LOCATED APPROXIMATELY 240' EAST OF OF THE NORTH WEST PROPERTY LINE ON HERNDON AVENUE.
- DIMENSIONS AND POINTS ARE TO CENTER OF FENCE POSTS, FACE OF BUILDINGS, TOP FACE OF CURB, OR EDGE OF CONCRETE, UNLESS SHOWN OTHERWISE.

HORIZONTAL CONTROL LEGEND:

- 100 LCP LAYOUT COORDINATE POINT
- 100 SLP SITE LAYOUT POINT
- 100 BLP BUILDING LAYOUT POINT
- BC BEGIN OF CURVE
- BW BLOCK WALL
- CC CORNER CONCRETE
- EC END OF CURVE
- FP FENCE POST
- GR DRAIN INLET GRATE
- MH MANHOLE
- PPC POINT OF COMPOUND CURVE
- PRC POINT OF REVERSE CURVE
- RP RADIUS POINT
- SL SITE LIGHT POLE

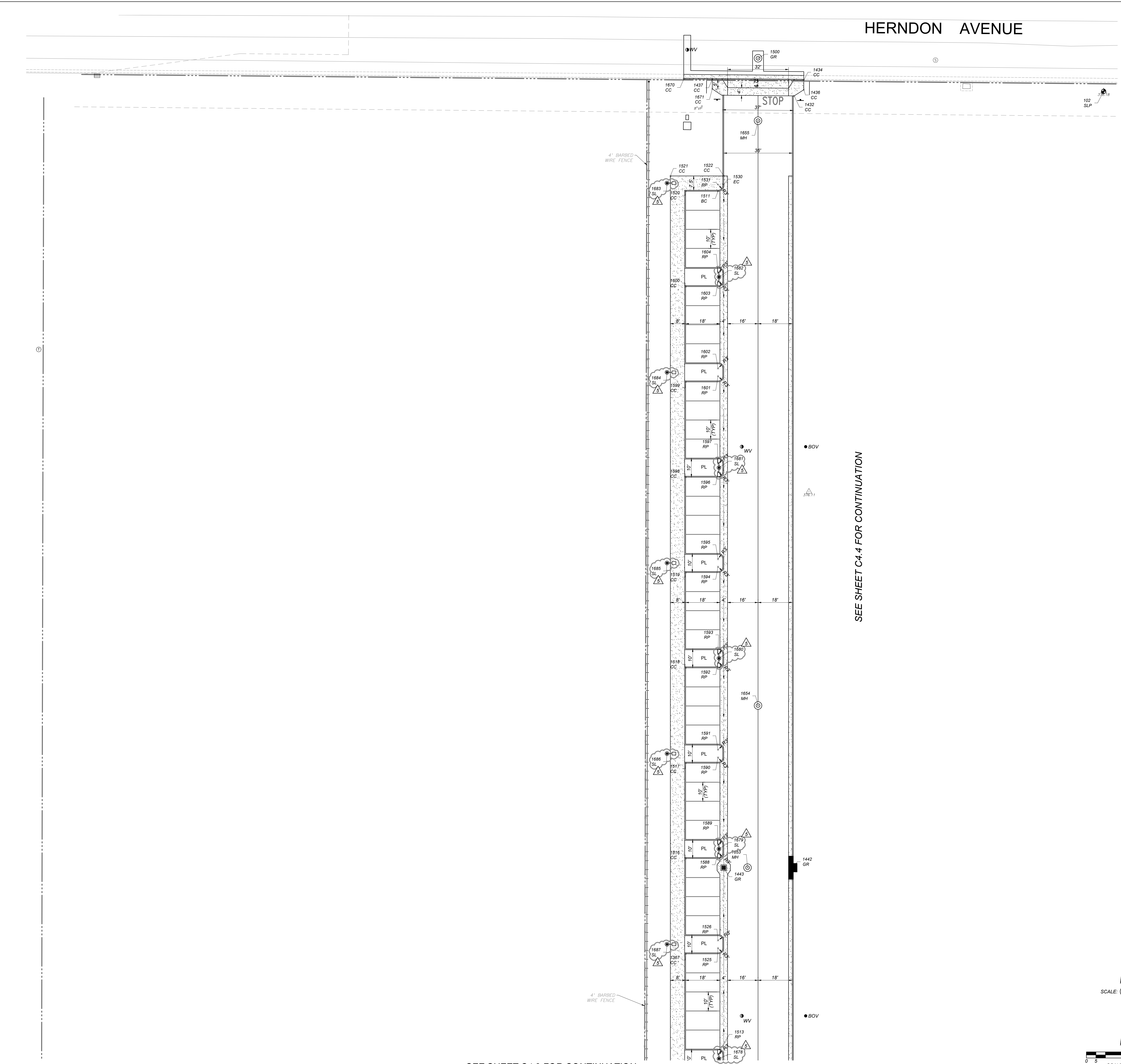

SEE SHEET C4.4 FOR CONTINUATION

SEE SHEET C4.2 FOR CONTINUATION

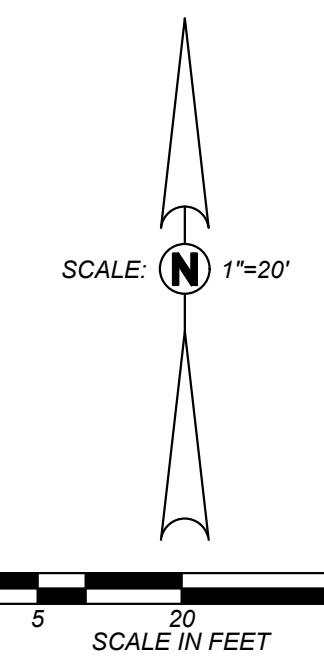
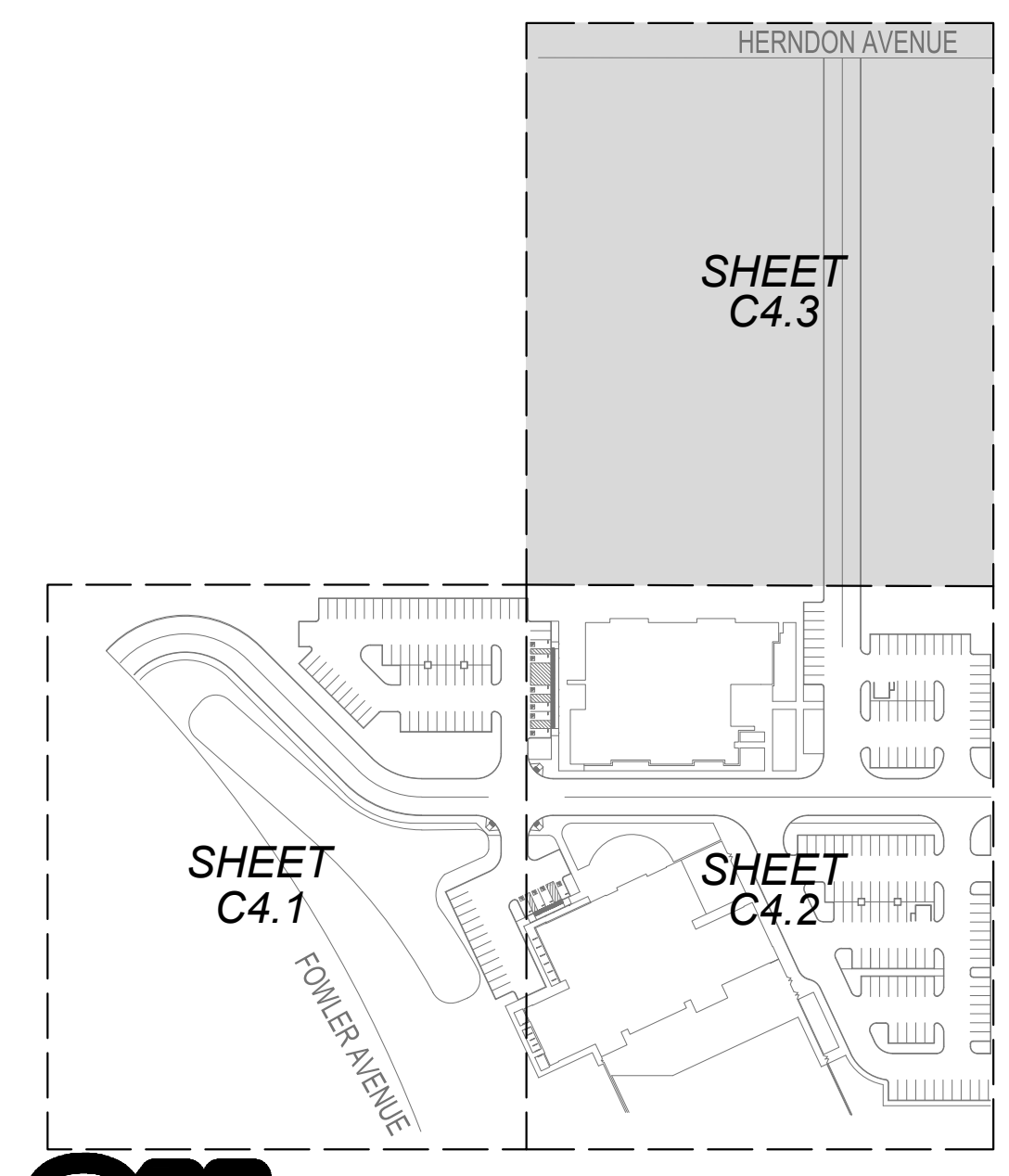

811
Know what's below.
Call before you dig.

Blair, Church & Flynn
CONSULTING ENGINEERS
481 Clark Avenue, Suite 200
Clovis, California 95312
Tel (509) 328-1400
Fax (509) 328-1800
Date: 12/12/2022
Data signed: [Signature]

MARK	DATE	DESCRIPTION	DSA BACKCHECK
△	10/26/23	ADDENDUM 5	

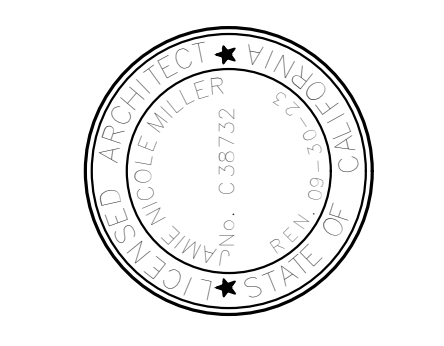

TETER, LLP
FRESNO HEADQUARTERS
VISALIA | BAKERSFIELD | MODOesto | SAN LUIS OBISPO
ARCHITECTS ENGINEERS CONNECTED

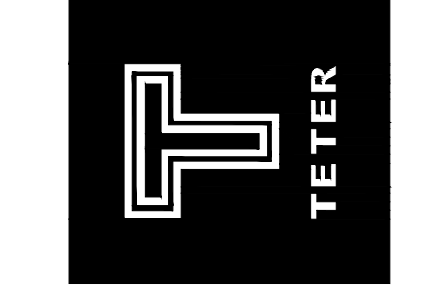

ONLINE SCHOOL & SPECIAL EDUCATION
ADMINISTRATION DISTRICT OFFICE EXPANSION
CLOVIS UNIFIED SCHOOL DISTRICT
CLOVIS, CA
DRAWING TITLE
PARTIAL HORIZONTAL CONTROL PLAN

PROJECT NO.
12242.00
DRAWING
C4.3

NORTHING EASTING TABLE table with columns: POINT, NORTHING, EASTING, ABV, DESCRIPTION

Table with columns: POINT, NORTHING, EASTING, ABV, DESCRIPTION

Table with columns: POINT, NORTHING, EASTING, ABV, DESCRIPTION

Table with columns: POINT, NORTHING, EASTING, ABV, DESCRIPTION

Table with columns: POINT, NORTHING, EASTING, ABV, DESCRIPTION

Table with columns: POINT, NORTHING, EASTING, ABV, DESCRIPTION

Table with columns: POINT, NORTHING, EASTING, ABV, DESCRIPTION

Table with columns: POINT, NORTHING, EASTING, ABV, DESCRIPTION

REVISIONS and APPROVALS table with columns: NO., DATE, INITIAL, PROJECT ENGINEER, CONSTRUCTION MANAGEMENT, PLANNING/BUILDING, TRAFFIC, UTILITIES/STREETS, CAPITAL PROJECTS

ADDITIONALS table with columns: MARK, DATE, DESCRIPTION, DSA CHECK

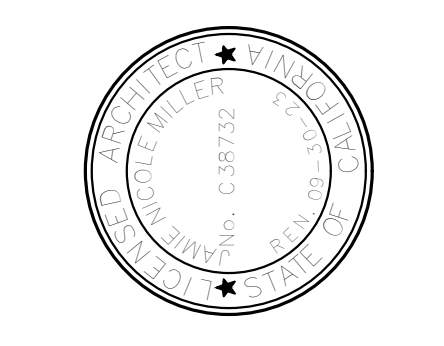

TETER, LLP FRESNO HEADQUARTERS VISALIA | BAKERSFIELD | MADERA | SAN LUIS OBISPO ARCHITECTS ENGINEERS CONNECTED

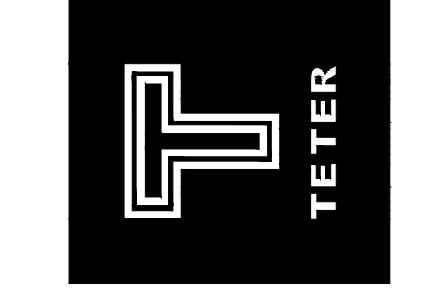

ONLINE SCHOOL & SPECIAL EDUCATION ADMINISTRATION DISTRICT OFFICE EXPANSION CLOVIS, CA CLOVIS UNIFIED SCHOOL DISTRICT HORIZONTAL CONTROL LEGEND

PROJECT NO. 12242.00 DRAWING TITLE C4.5

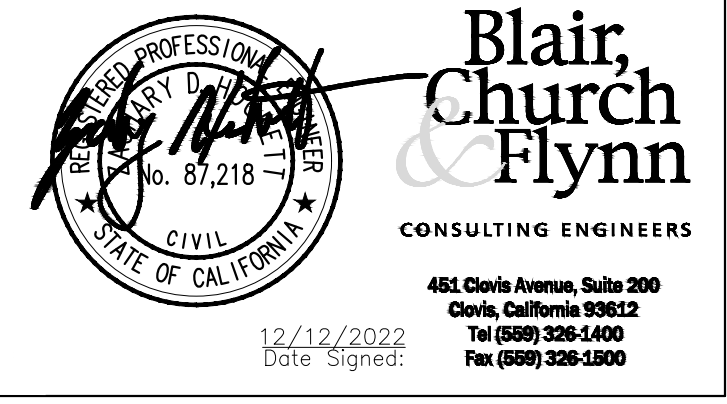

481 Clark Avenue, Suite 200 Clovis, California 93612 Tel: (559) 326-1400 Fax: (559) 326-1500

P:\2021-08\1\Site\ProductionDrawings\221361_Lgr.dwg

SEE SHEET C5.3 FOR CONTINUATION

SEE SHEET C5.1 FOR CONTINUATION

SEE SHEET C5.4 FOR CONTINUATION

PLOT DATE: 10/25/2023 1:13:12 PM

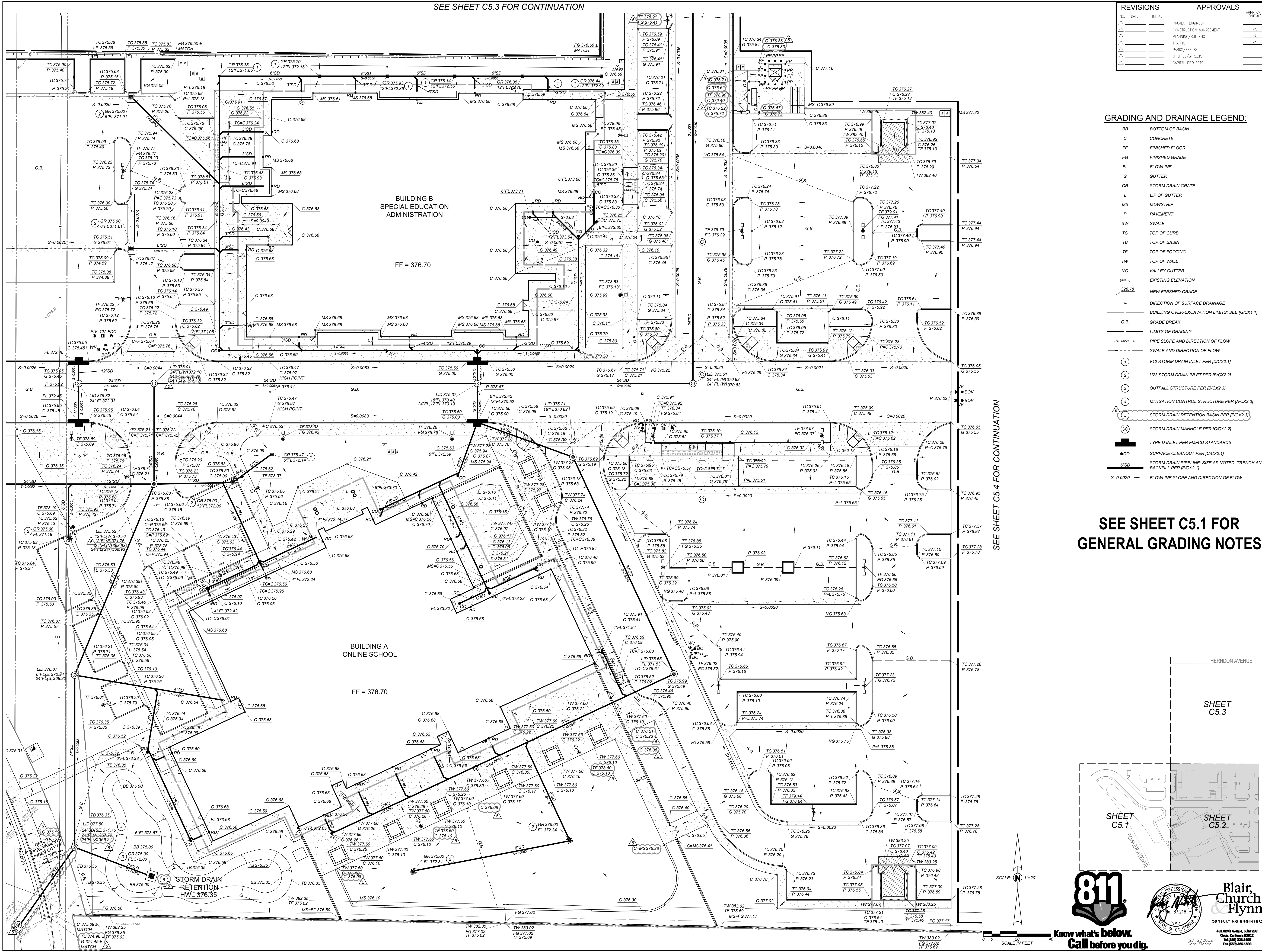

REVISIONS			APPROVALS		
NO.	DATE	INITIAL	PROJECT ENGINEER	CONSTRUCTION MANAGEMENT	PLANNING/BUILDING

GRADING AND DRAINAGE LEGEND:

- BB BOTTOM OF BASIN
- C CONCRETE
- FF FINISHED FLOOR
- FG FINISHED GRADE
- FL FLOWLINE
- G GUTTER
- GR STORM DRAIN GRATE
- L LIP OF GUTTER
- MS MOWSTRIP
- P PAVEMENT
- SW SWALE
- TC TOP OF CURB
- TB TOP OF BASIN
- TF TOP OF FOOTING
- TW TOP OF WALL
- VG VALLEY GUTTER
- (344.9) EXISTING ELEVATION
- 328.78 NEW FINISHED GRADE
- DIRECTION OF SURFACE DRAINAGE
- BUILDING OVER-EXCAVATION LIMITS, SEE (G/CX1.1)
- G.B. GRADE BREAK
- LIMITS OF GRADING
- S=0.0020 PIPE SLOPE AND DIRECTION OF FLOW
- SWALE AND DIRECTION OF FLOW
- ① V12 STORM DRAIN INLET PER (D/CX2.1)
- ② U23 STORM DRAIN INLET PER (B/CX2.2)
- ③ OUTFALL STRUCTURE PER (B/CX2.3)
- ④ MITIGATION CONTROL STRUCTURE PER (A/CX2.3)
- ⑤ STORM DRAIN RETENTION BASIN PER (B/CX2.3)
- ⑥ STORM DRAIN MANHOLE PER (C/CX2.2)
- TYPE D INLET PER FMFCD STANDARDS
- CO SURFACE CLEANOUT PER (C/CX2.1)
- 6"SD STORM DRAIN PIPELINE, SIZE AS NOTED. TRENCH AND BACKFILL PER (B/CX2.1)
- S=0.0020 FLOWLINE SLOPE AND DIRECTION OF FLOW

SEE SHEET C5.1 FOR GENERAL GRADING NOTES

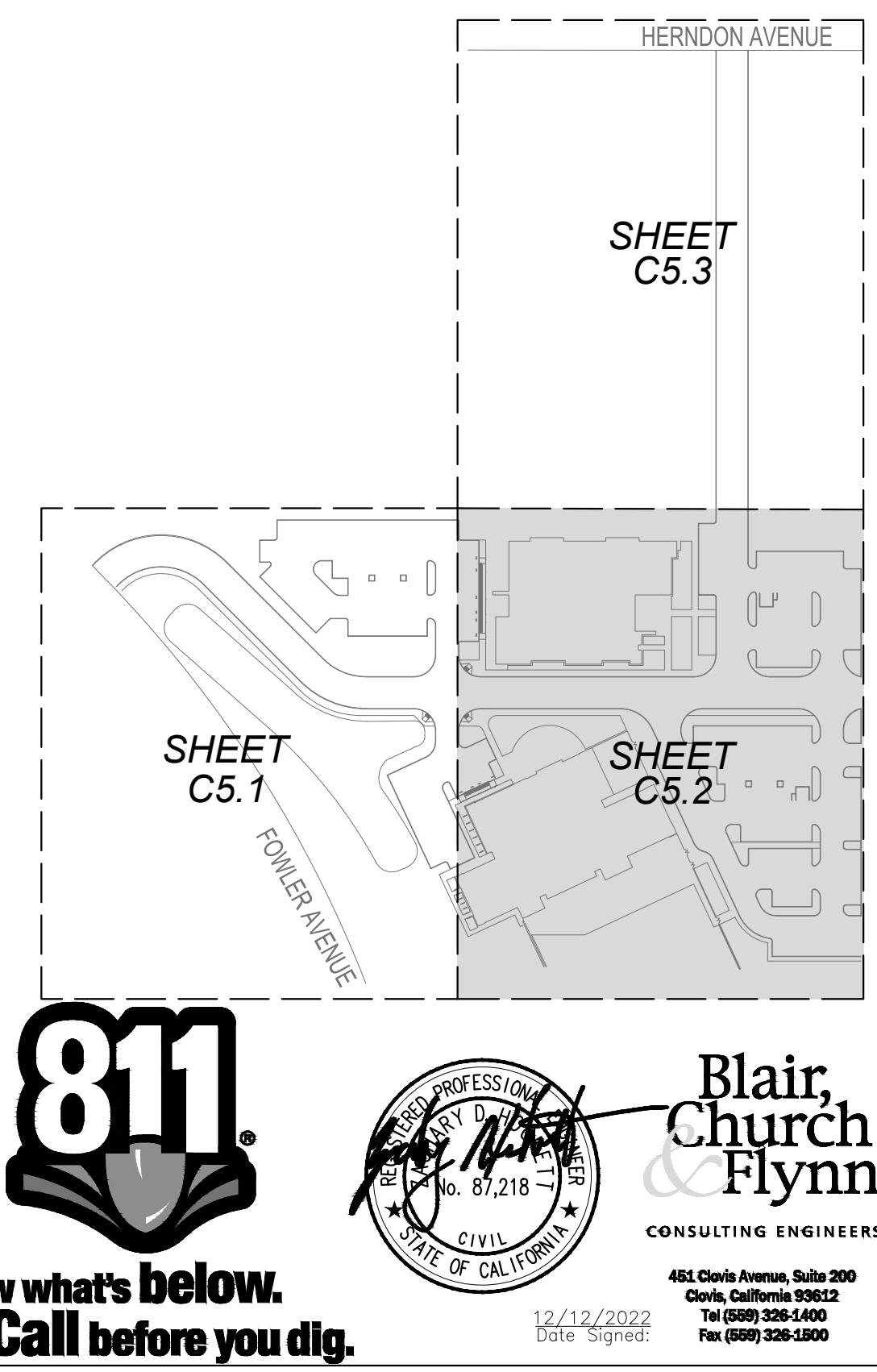

MARK	DATE	DESCRIPTION	DSA BACKCHECK

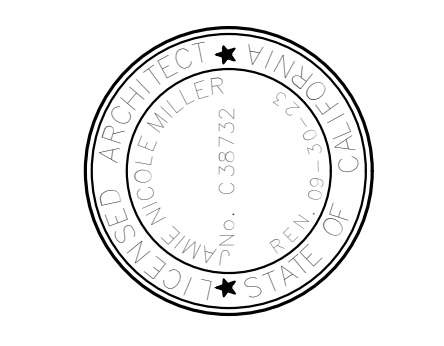

TETER, LLP
 FRESNO HEADQUARTERS
 VISALIA | BAKERSFIELD | MADERA | SAN LUIS OBISPO
ARCHITECTS ENGINEERS CONNECTED

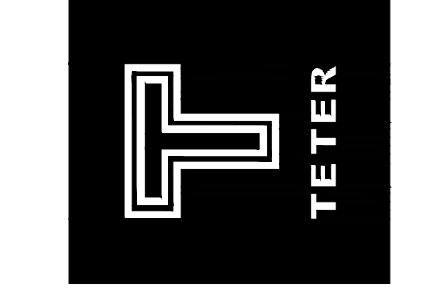

ONLINE SCHOOL & SPECIAL EDUCATION ADMINISTRATION DISTRICT OFFICE EXPANSION CLOVIS UNIFIED SCHOOL DISTRICT
 CLOVIS, CA
 PARTIAL GRADING AND DRAINAGE PLAN
 PROJECT NO. 12242.00
 DRAWING TITLE **C5.2**

Blair, Church & Flynn
 CONSULTING ENGINEERS
 481 Clark Avenue, Suite 200
 Clovis, California 93240
 Tel: (559) 238-1400
 Fax: (559) 238-1800
 12/12/2022 Date signed: [Signature]
 Know what's below. Call before you dig.

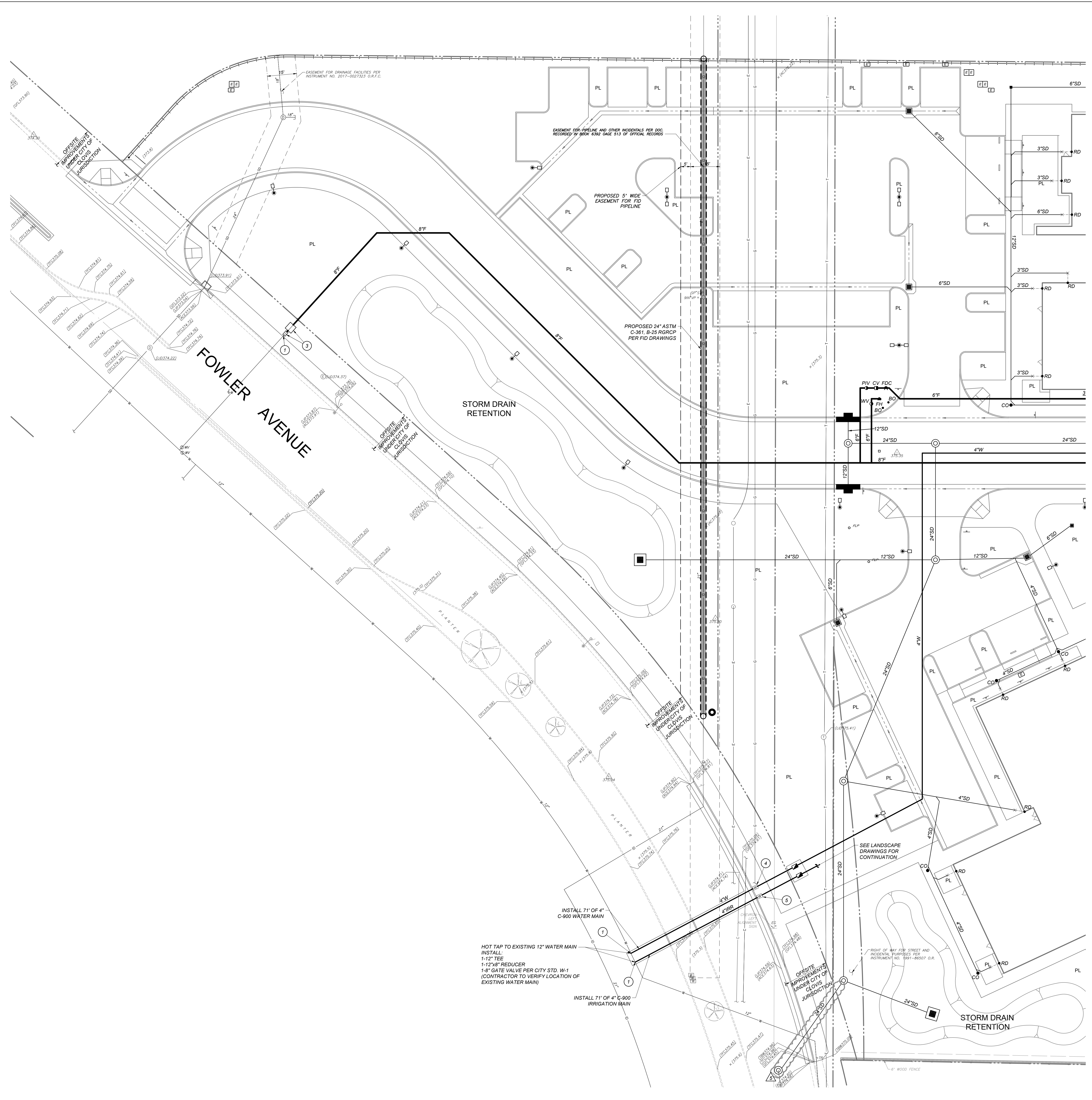

REVISIONS			APPROVALS		
NO.	DATE	INITIAL	PROJECT ENGINEER	CONSTRUCTION MANAGEMENT	PLANNING/BUILDING

- UTILITY LEGEND:**
- 6"SD PVC SEWER MAIN, SIZE AS NOTED ON PLANS, PIPE BEDDING AND BACKFILL PER (E/CX2.1)
 - 8"SD PVC WATER MAIN, SIZE AS NOTED ON PLANS, MIN. 30" COVER, THRUST BLOCKS PER (A/CX2.1), PIPE BEDDING AND BACKFILL PER (E/CX2.1)
 - 8"SD PVC FIRE MAIN, SIZE AS NOTED ON PLANS, MIN. 42" COVER, THRUST BLOCKS PER (A/CX2.1), PIPE BEDDING AND BACKFILL PER (E/CX2.1)
 - 6"SD STORM DRAIN PIPE, SEE GRADING PLAN
 - FL FLOWLINE
 - 328.78 NEW FINISHED GRADE
 - BACKFLOW PREVENTER PER CITY OF CLOVIS STD. W-18, SEE (D/CX2.3)
 - BOV BLOW-OFF VALVE PER CITY OF CLOVIS STD. W-13
 - CO SEWER CLEANOUT PER (C/CX2.1)
 - CV CHECK VALVE PER (I/CX2.1)
 - FDC FIRE DEPARTMENT CONNECTION PER (I/CX2.1)
 - FH FIRE HYDRANT ASSEMBLY PER (J/CX2.1)
 - PIV POST INDICATOR VALVE PER (I/CX2.1)
 - RD ROOF DRAIN
 - WV WATER VALVE PER (B/CX2.1)
 - SM SEWER MANHOLE PER (H/CX2.1)
 - CEW CAP END OF UTILITY LINE
 - POINT OF CONNECTION TO EXISTING OR PROPOSED UTILITY, COORDINATE WITH PLUMBING PLANS PRIOR TO CONNECTION.
 - FLOWLINE SLOPE AND DIRECTION OF FLOW
 - CONNECT TO EXISTING WATER LINE WITH WATER-TIGHT CONNECTION, VERIFY SIZE, DEPTH, AND LOCATION.
 - CONNECT TO EXISTING SEWER LINE WITH WATER-TIGHT CONNECTION, VERIFY SIZE, DEPTH, AND LOCATION.
 - FIRE SERVICE PER CITY OF CLOVIS STD. DWG. W-4 AND CLOVIS FIRE DEPT. STD. DWG. 2.1, SEE (C/CX2.3)
 - 4" COMPOUND WATER METER PER CITY OF CLOVIS STD. W-8
 - 4" TURBO WATER METER PER CITY OF CLOVIS STD. W-11
 - SEWER MANHOLE PER CITY OF CLOVIS STD. S-2

- GENERAL SITE UTILITY NOTES:**
- AS FIRST ORDER OF WORK, CONTRACTOR SHALL POT HOLE EXISTING UTILITIES AND NOTIFY ENGINEER IMMEDIATELY OF LOCATIONS, SIZE AND DEPTH.
 - THE CONTRACTOR SHALL FIELD VERIFY THE EXACT LOCATION, SIZE, DEPTH, AND TYPE OF ALL EXISTING UTILITIES AND INTERFERENCES SITUATED ALONG THE ROUTE OF THE PROPOSED CONSTRUCTION PRIOR TO COMMENCEMENT OF EXCAVATION, FABRICATION, AND INSTALLATION. THE CONTRACTOR SHALL CONSTRUCT ALL IMPROVEMENTS IN SUCH A MANNER AS WILL PROTECT ALL EXISTING UNDERGROUND UTILITIES AND, IN THE EVENT OF ANY CONFLICTS, SHALL NOTIFY THE ENGINEER BEFORE PROCEEDING.
 - SEE IRRIGATION PLANS FOR PROPOSED IRRIGATION PIPE ALIGNMENT.
 - COORDINATE EXACT POINTS OF CONNECTION TO BUILDING PLUMBING AND NOTIFY THE ENGINEER OF ANY CONFLICTS SO THAT ADJUSTMENTS CAN BE MADE IF NEEDED.
 - SAWCUT EXISTING CONCRETE IMPROVEMENTS AS NECESSARY TO INSTALL NEW WATER OR SEWER IMPROVEMENTS. CONSTRUCT NEW CONCRETE IMPROVEMENTS TO MATCH ADJACENT CONCRETE IMPROVEMENTS AND JOIN TOGETHER WITH DOWEL BARS PER (H/CX2.1)
 - INSTALLATION, TYPE, AND MANUFACTURER'S MODELS OF DOMESTIC WATER METERS, DRAIN INLETS/OUTLETS AND OTHER APPURTENANCES OF SITE UTILITY SYSTEMS SHALL BE DONE IN STRICT ACCORDANCE WITH GOVERNING AUTHORITY REQUIREMENTS.
 - LAYOUT OF MATERIALS, EQUIPMENT AND SYSTEMS IS GENERALLY DIAGRAMMATIC UNLESS SPECIFICALLY DIMENSIONED. SOME WORK MAY BE SHOWN OFFSET FOR CLARITY. THE ACTUAL LOCATIONS OF ALL MATERIALS, PIPING, FIXTURES, EQUIPMENT, SUPPORTS, ETC. SHALL BE CAREFULLY PLANNED PRIOR TO INSTALLATION OF ANY WORK TO AVOID ALL INTERFERENCES WITH EACH OTHER OR WITH STRUCTURAL, ELECTRICAL, PLUMBING AND MECHANICAL, ARCHITECTURAL OR ANY OTHER ELEMENTS. ALL CONFLICTS SHALL BE CALLED TO THE ATTENTION OF THE ARCHITECT AND THE ENGINEER PRIOR TO THE INSTALLATION OF ANY WORK OR THE ORDERING OF ANY EQUIPMENT.
 - ANY INSPECTION TO BE MADE BY THE AUTHORITY HAVING JURISDICTION SHALL REQUIRE A MINIMUM OF 24 HOUR NOTICE.
 - PURITY TESTS ARE REQUIRED ON ALL WATER SYSTEM INSTALLATIONS. CONTRACTOR TO COORDINATE WITH THE AUTHORITY HAVING JURISDICTION.
 - IF THE TOP OF THE STEM OF ANY WATER GATE VALVE IS DEEPER THAN 4" BELOW FINISHED PAVEMENT GRADE, THE CONTRACTOR SHALL INSTALL A STEM EXTENSION SO THAT THE TOP OF THE STEM, WITH EXTENSION, SHALL BE NO DEEPER THAN 4" NOR SHALLOWER THAN 2" FROM FINISHED GRADE.
 - BACKFILL UTILITY TRENCHES PER (E/CX2.1)
 - ADJUST EXISTING UTILITY LIDS TO FINISHED GRADE PER UTILITY COMPANY STANDARDS AND PER (F/CX2.1) AND INSTALL TRAFFIC RATED LIDS WHERE LOCATED IN A TRAFFIC AREA.

SEE SHEET C6.2 FOR CONTINUATION

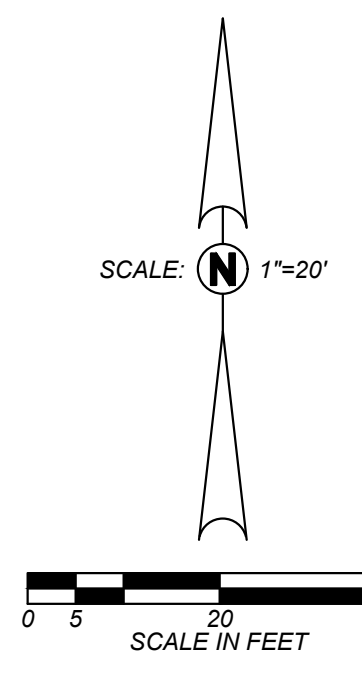
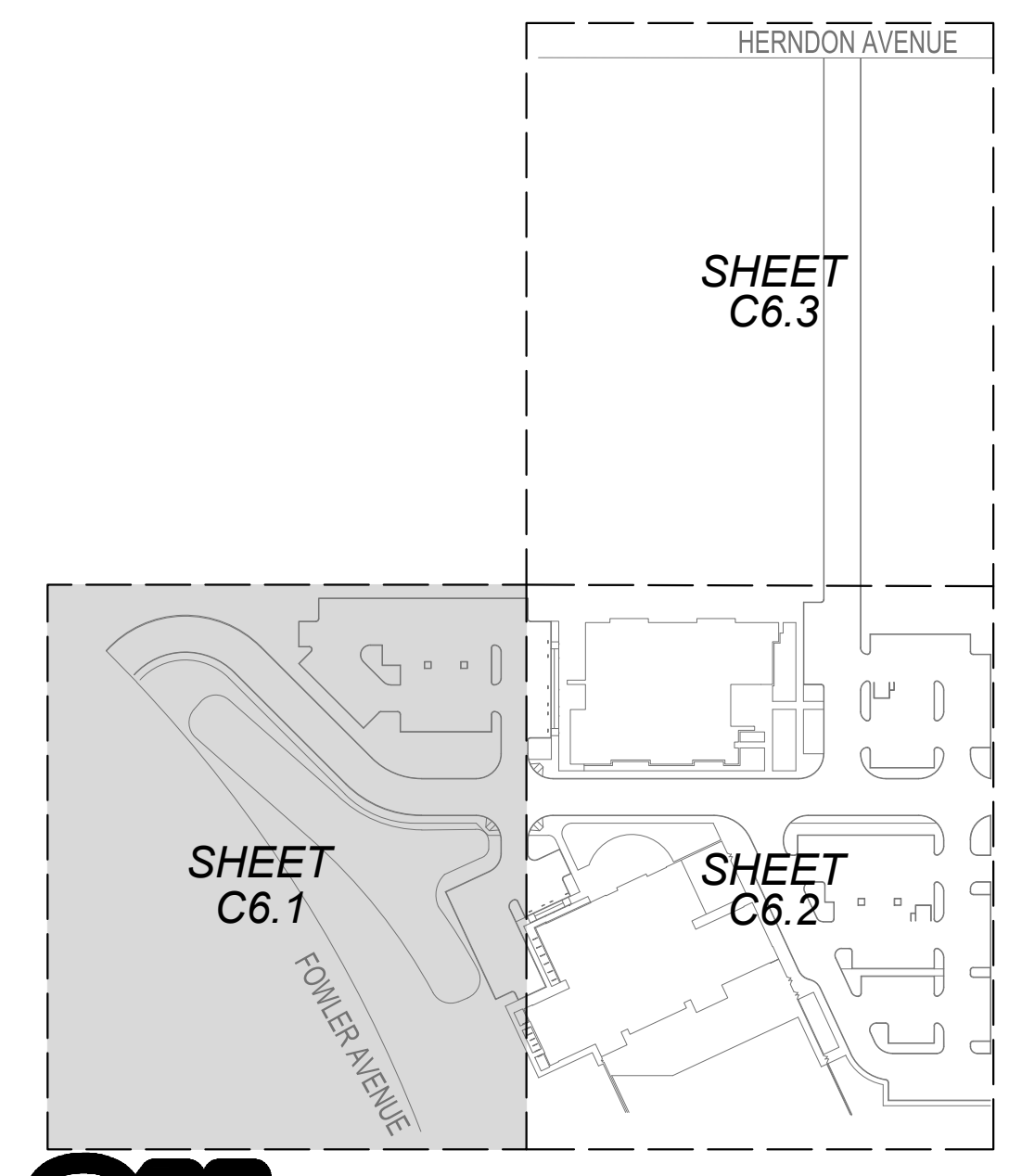

811 Know what's below. Call before you dig.

Blair, Church & Flynn
CONSULTING ENGINEERS
481 Clovis Avenue, Suite 200
Clovis, California 95323
Tel (509) 328-1400
Fax (509) 328-1500
12/12/2022
Data signed: [Signature]

TETER, LLP
ARCHITECTS ENGINEERS CONNECTED
PRESNO HEADQUARTERS
VISALIA | BAKERSFIELD | MADERA | SAN LUIS OBISPO

ONLINE SCHOOL & SPECIAL EDUCATION ADMINISTRATION DISTRICT OFFICE EXPANSION
CLOVIS UNIFIED SCHOOL DISTRICT
CLOVIS, CA
DRAWING TITLE: PARTIAL UTILITY PLAN

PROJECT NO. 12242.00
DRAWING C6.1

DATE: 10/25/23
DRAWN: [Name]
CHECKED: [Name]
APPROVED: [Signature]

NOTES:

1. PRECAST PIPE, ADJUSTING RINGS AND TAPERED SECTIONS SHALL BE CONSTRUCTED IN ACCORDANCE WITH A.S.T.M. C-478, USING TYPE II CEMENT.
2. ALL JOINTS BETWEEN PRECAST SECTIONS SHALL BE MORTARED.
3. INTERIOR OF THE MANHOLE SHALL HAVE A SMOOTH TROWELED SURFACE, (WOOD TROWEL).

CONCRETE COLLAR 2" BELOW COVER, 2" ASPHALT CONCRETE FLUSH WITH COVER IN ASPHALT PAVEMENT PAVED INSTALLATIONS.

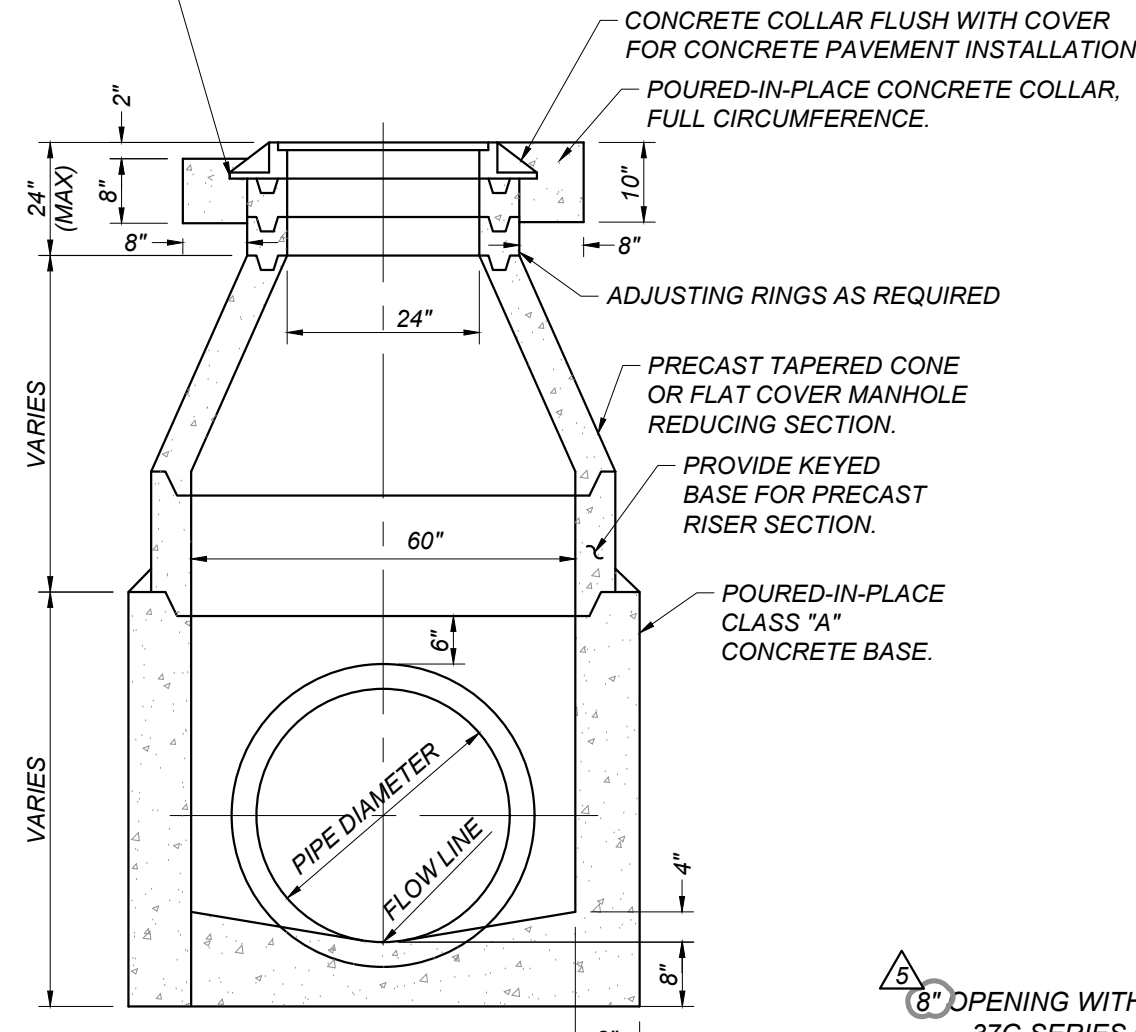

SECTION "A-A"
NOT TO SCALE

A FMFCD MITIGATION CONTROL STRUCTURE
CX2.3 NOT TO SCALE

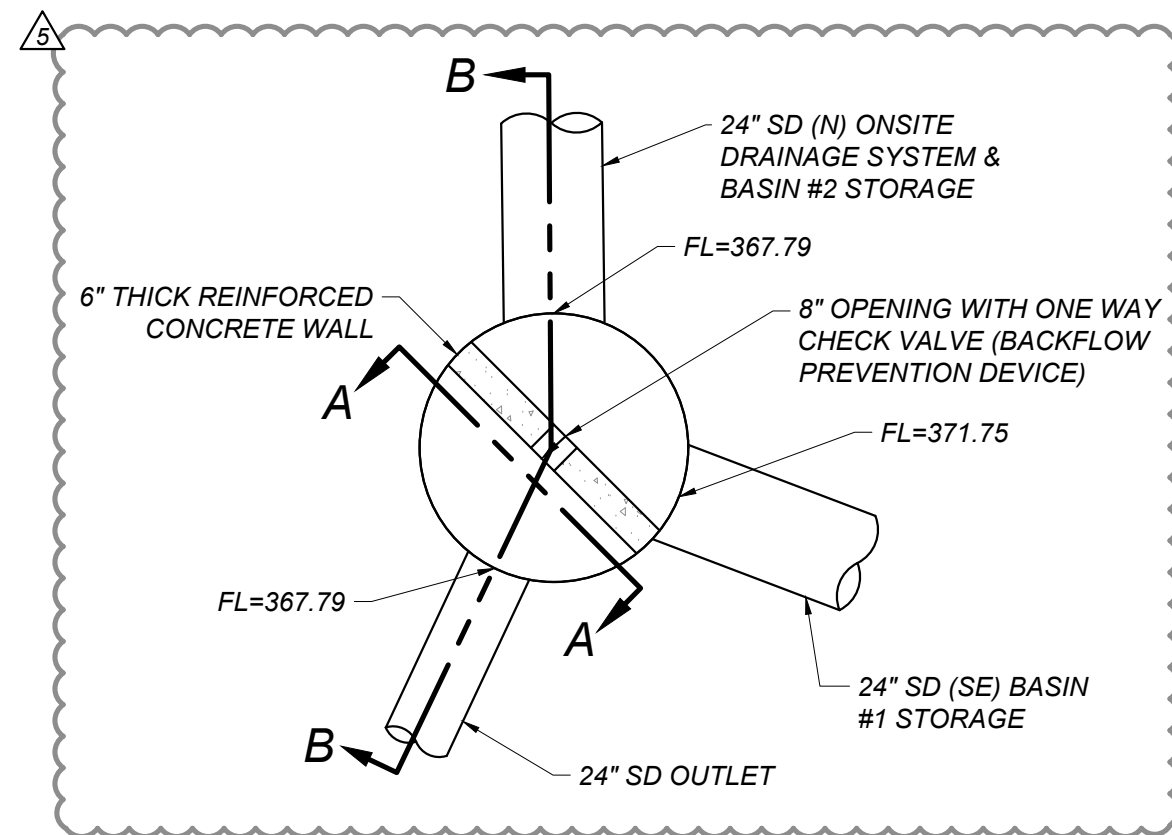

PLAN
NOT TO SCALE

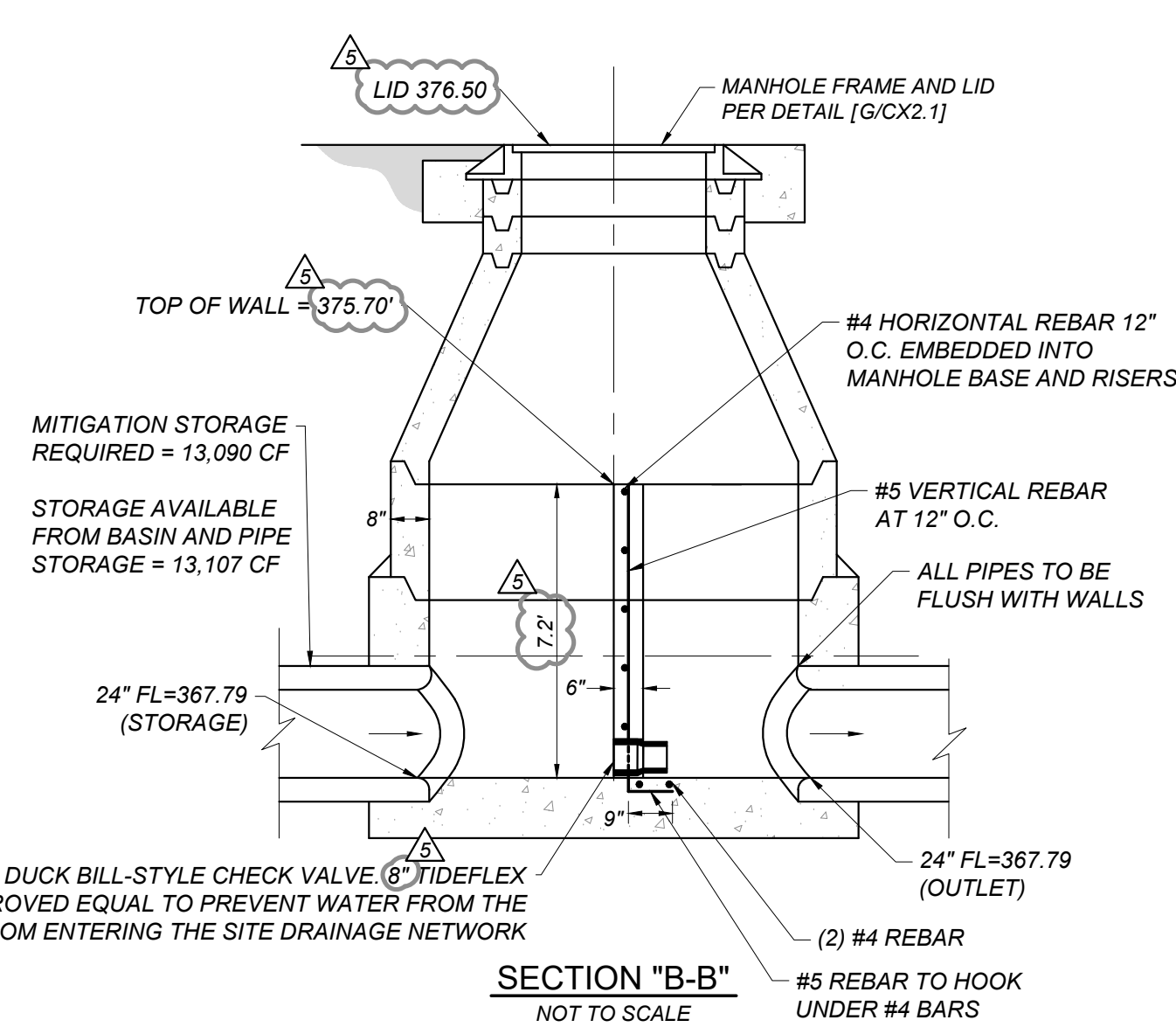

SECTION "B-B"
NOT TO SCALE

B OUTFALL STRUCTURE
CX2.3 NOT TO SCALE

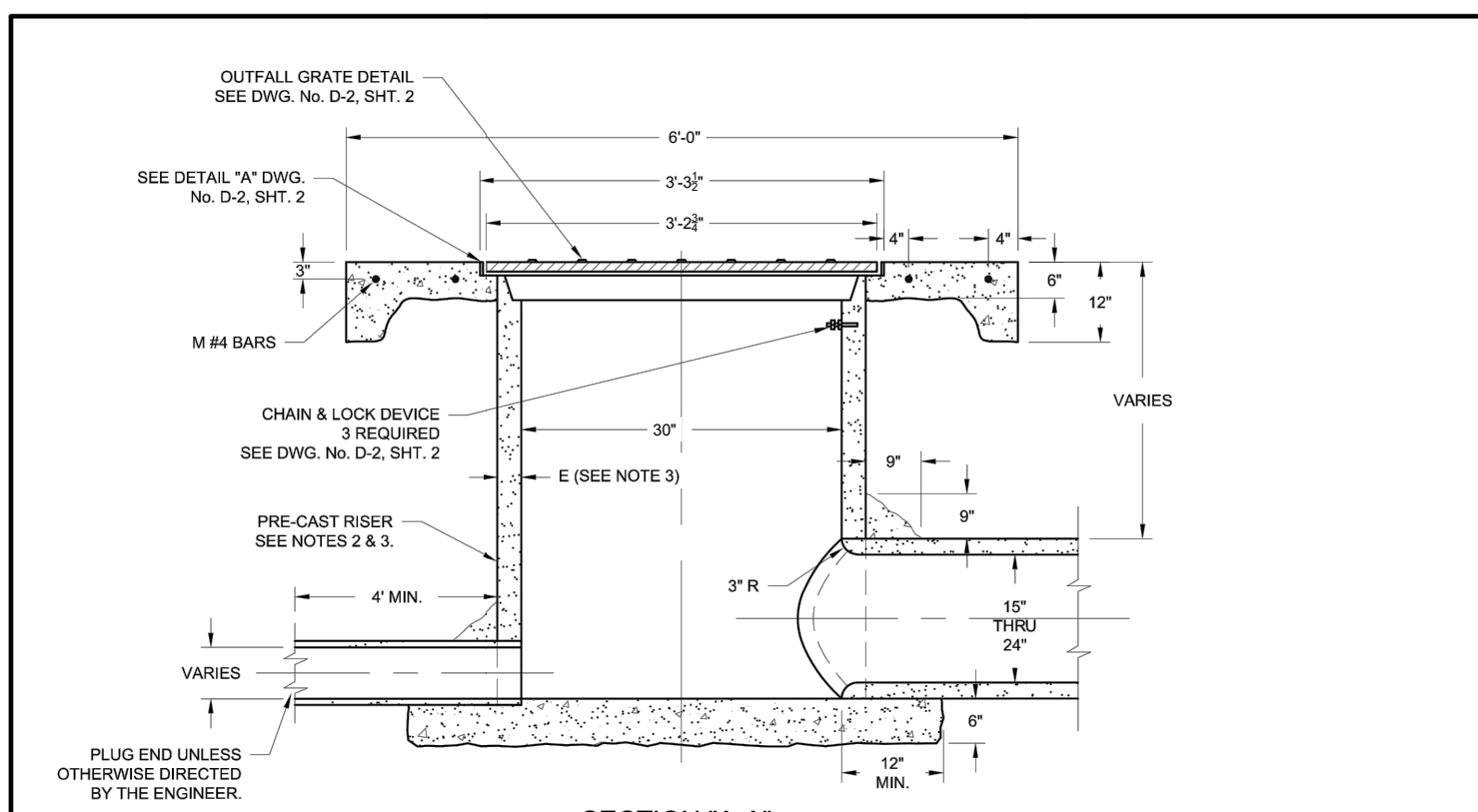

SECTION "A-A"
N.T.S.

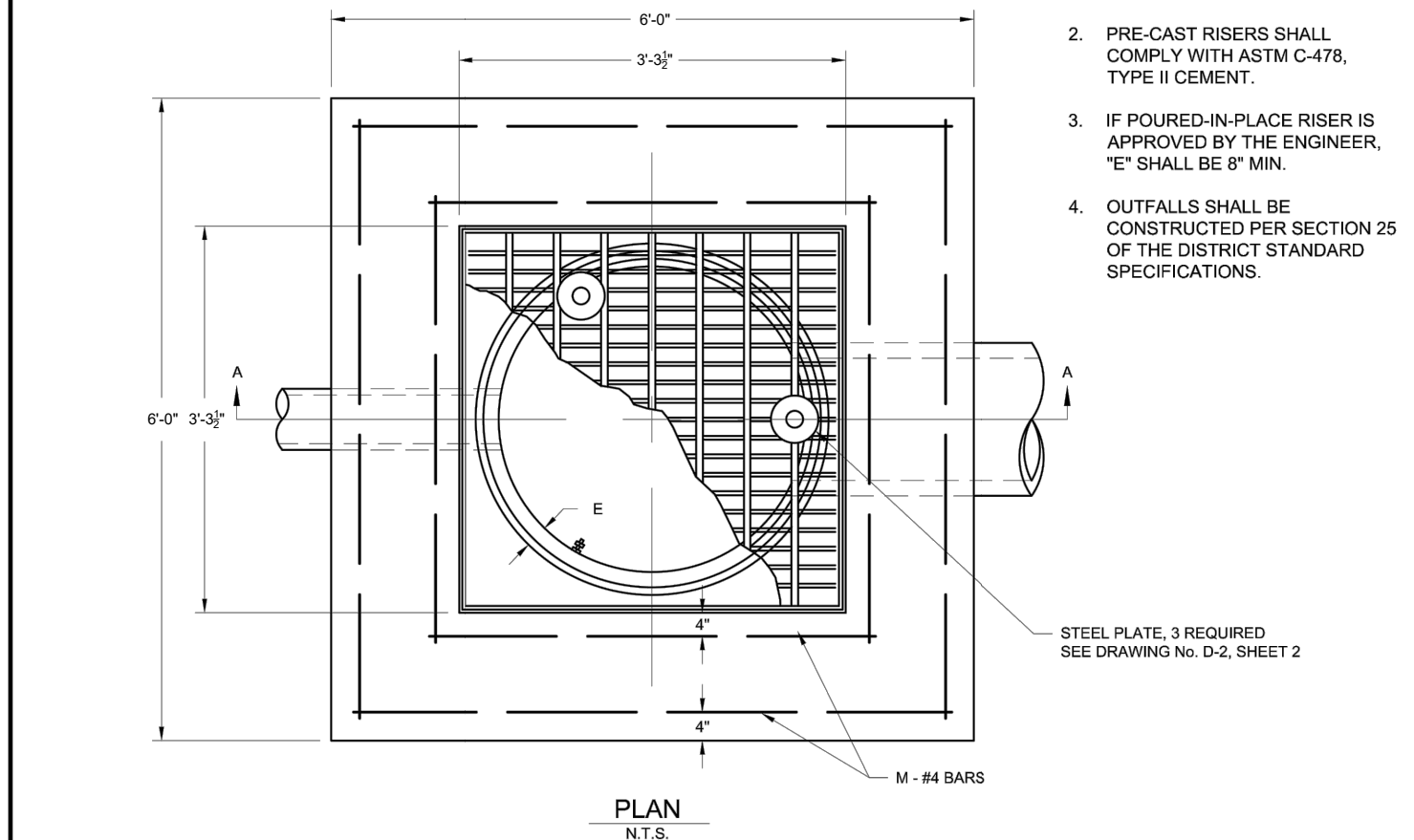

PLAN
N.T.S.

REVISIONS			FRESNO METROPOLITAN FLOOD CONTROL DISTRICT		OUTFALL STRUCTURES TYPES A, B & C	
MARK	DATE	DESCRIPTION	APPROVED BY:	SCALE AS SHOWN	DRAWING No. D-2 SHEET 1 OF 2	
ADOPTED	4/1/2011		DISTRICT ENGINEER			

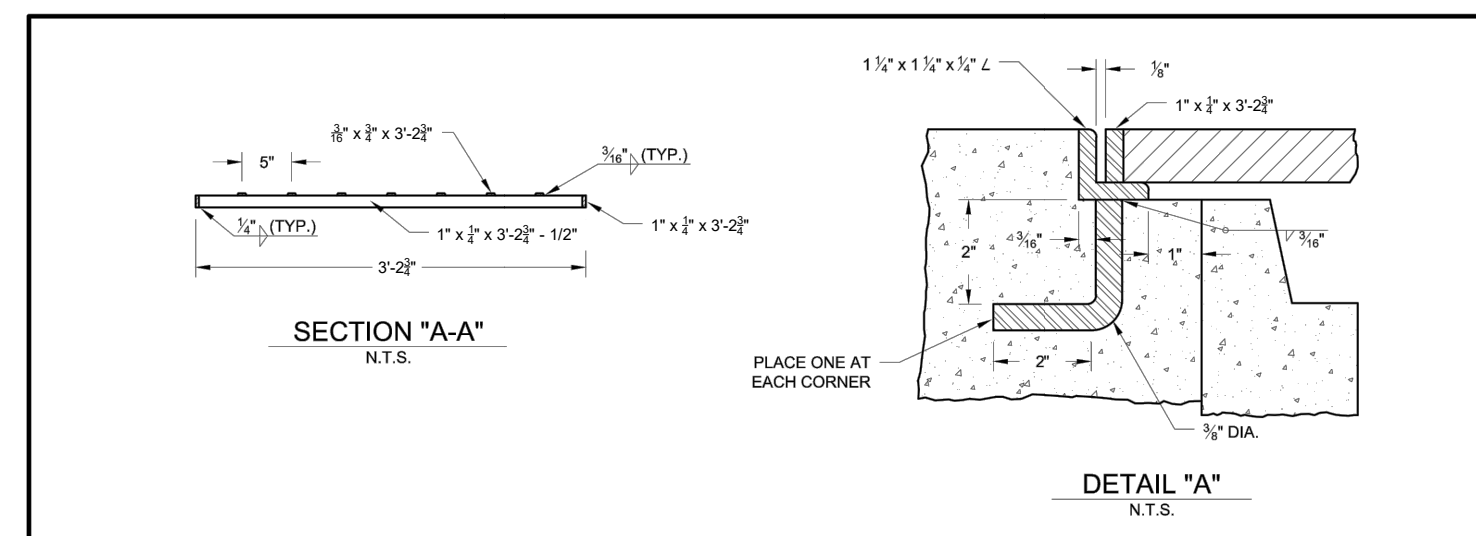

SECTION "A-A"
N.T.S.

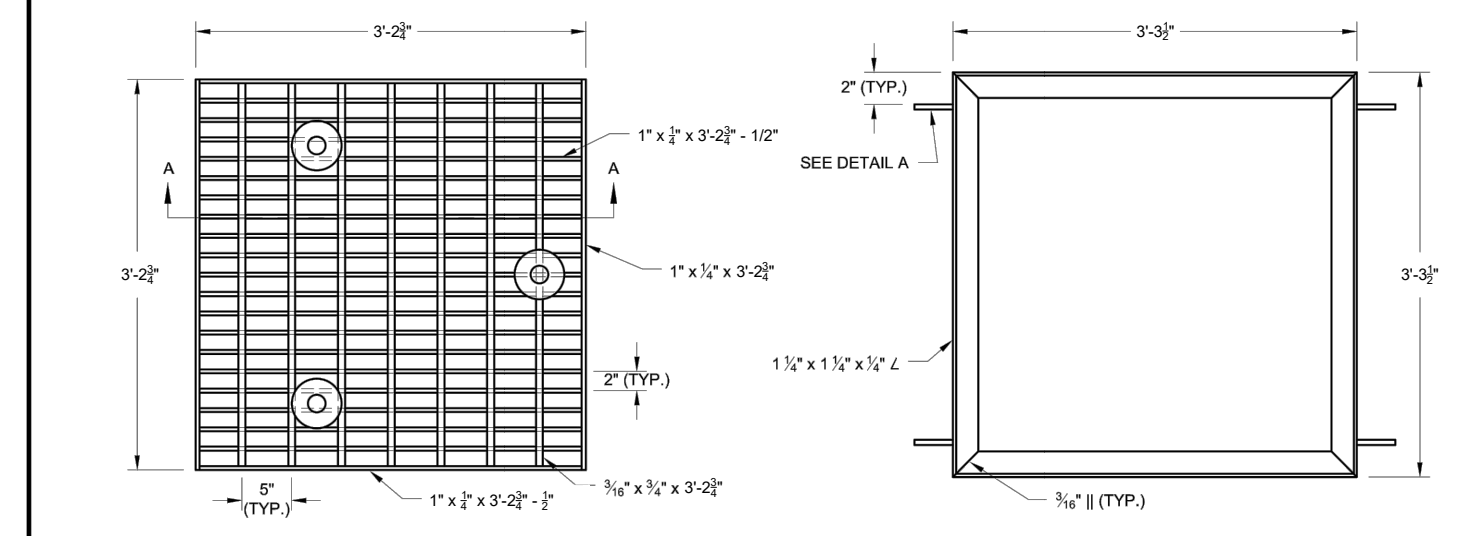

PLAN
N.T.S.

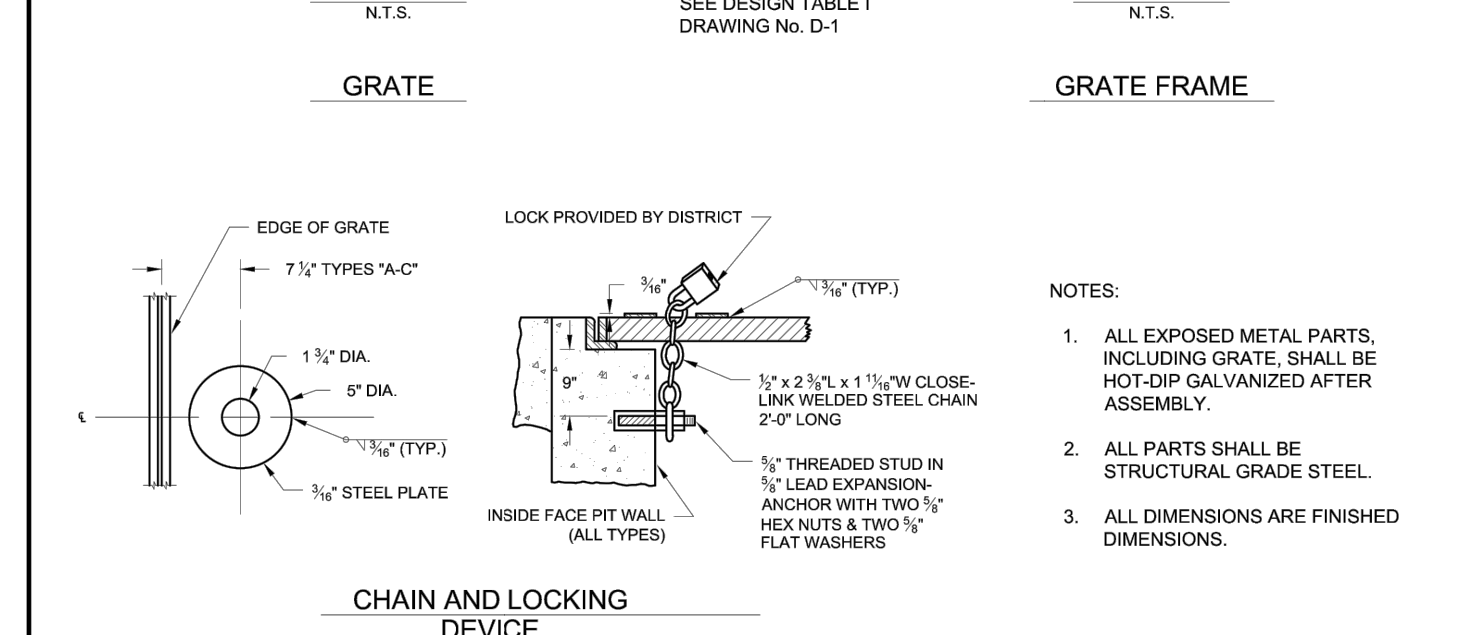

REVISIONS			FRESNO METROPOLITAN FLOOD CONTROL DISTRICT		OUTFALL STRUCTURES FRAME & GRATE DETAILS	
MARK	DATE	DESCRIPTION	APPROVED BY:	SCALE AS SHOWN	DRAWING No. D-2 SHEET 2 OF 2	
ADOPTED	4/1/2011		DISTRICT ENGINEER			

Clovis Fire Department Standard 2.1
Fire Sprinkler Underground

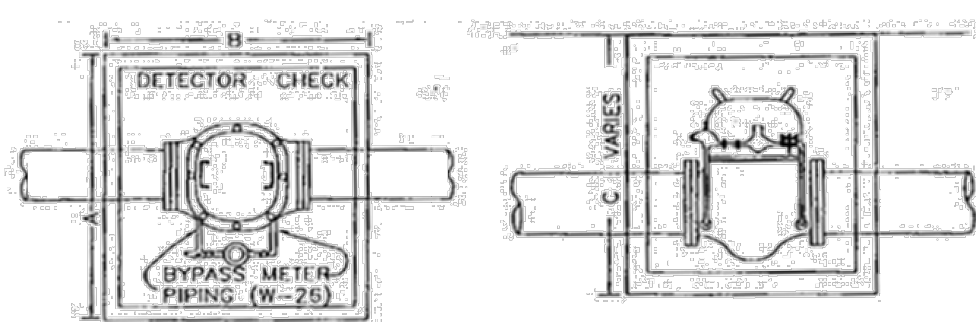

MINIMUM VAULT SIZE	A B C		
	4"	36"	36"
6"	42"	48"	30"
8"	48"	48"	30"
10"	48"	60"	42"

DEPTH VARIES

- NOTES:**
1. DETECTOR CHECK VALVE TO BE AN AMES 1000 OR FISCO MODEL 800 OR APPROVED EQUAL.
 2. CHECK VALVE TO BE TAPPED AND PLUGGED FOR INSTALLATION OF BYPASS METER PIPING.
 3. VAULT TO BE CRISTY, BROOKS OR APPROVED EQUAL.
 4. VAULT TO PROVIDE MINIMUM OF 12" CLEARANCE AROUND CHECK AND BYPASS METER.
 5. VAULT, DETECTOR CHECK VALVE AND VAULT COVER TO BE INSTALLED BY DEVELOPER / CONTRACTOR AS PER STD 2.1.

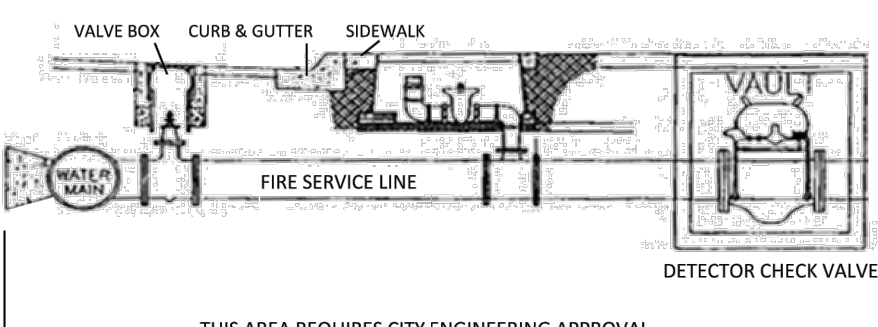

THIS AREA REQUIRES CITY ENGINEERING APPROVAL

C FIRE WATER BACKFLOW PREVENTION DEVICE
CX2.3 NOT TO SCALE

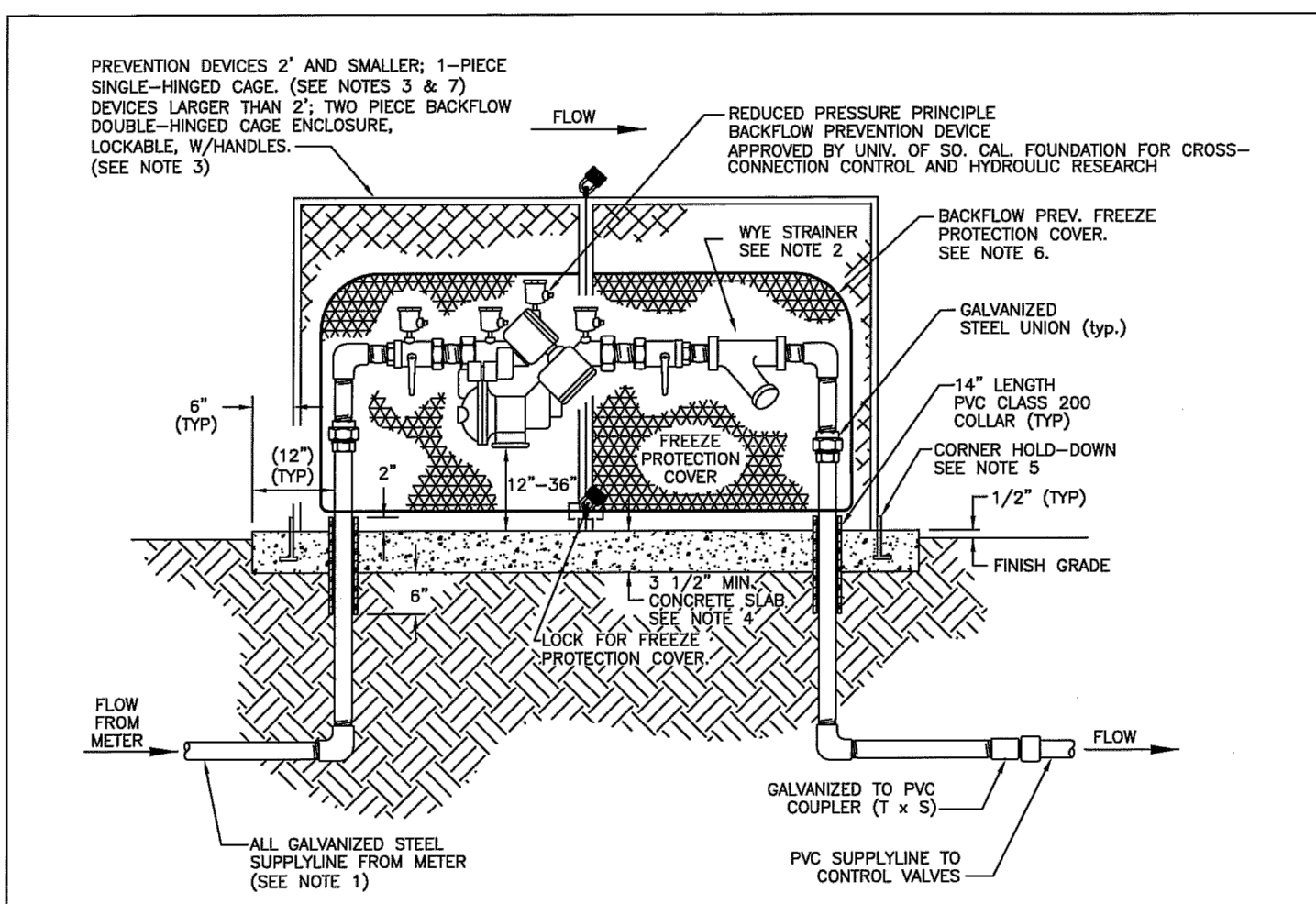

- NOTES:**
1. ALL GALVANIZED STEEL PIPE AND FITTINGS BELOW GRADE TO BE PRIMED AND WRAPPED WITH A 50 PERCENT OVERLAP OF 10 MIL CORROSION PROTECTION TAPE (SCOTCHPAK OR EQUAL).
 2. 150 MESH WYE STRAINER WITH BALL VALVE REQUIRED FOR DRIP OR LOW FLOW APPLICATIONS. ROTATE STRAINER 30 DEGREES DOWNWARD FROM HORIZONTAL.
 3. SIZE OF BACKFLOW PREVENTER SHALL DICTATE THE SIZE OF THE ENCLOSURE. CONSULT ENCLOSURE MANUFACTURER'S LITERATURE TO DETERMINE CORRECT MODEL NUMBER.
 4. SIZE OF THE ENCLOSURE SHALL INDICATE THE SIZE OF THE CONCRETE PAD, WHICH SHALL BE 15 CM (6") LARGER, ON ALL SIDES, THAN THE ENCLOSURE. THE PAD SHALL BE SUFFICIENTLY THICK TO EXTEND 8 CM (3") MIN. BELOW GRADE OR ALL SIDES. TOP OF PAD TO BE SLOPED TO DRAIN.
 5. CORNER HOLD-DOWN ASSEMBLIES FOR ENCLOSURE SHALL BE EMBEDDED IN CONCRETE PAD PER MANUFACTURER'S SPEC.
 6. A BACKFLOW PREVENTER FREEZE PROTECTION COVER SHALL BE INSTALLED OVER THE BACKFLOW PREVENTER.
 7. WHEN FABRICATING 1-PIECE SINGLE-HINGED COVER ALLOW FOR FREEZE PROTECTION COVER CLEARANCE WHEN OPENING AND CLOSING COVER.

IMPORTANT

THE BACKFLOW PREVENTION ASSEMBLY SHALL BE TESTED AND APPROVED BY AN APPROVED AWWA OR AWWA CERTIFIED TESTER WITHIN FIVE (5) DAYS OF INSTALLATION WITH THE RESULTS SENT TO THE CITY BACKFLOW PROGRAM COORDINATOR VIA:

MIL TO: 155 N. SUNNYSIDE, CLOVIS, CA 93611
 FAX: (509) 324-2862
 IN PERSON: CITY OF CLOVIS PUBLIC UTILITIES DEPT., 155 N. SUNNYSIDE, CLOVIS, CA 93611
 2ND FLOOR - ADMIN. BLDG.

A LIST OF THE CITY'S APPROVED BACKFLOW TESTERS MAY BE OBTAINED THROUGH THE CITY WEBSITE AT: www.cityofclovis.com UNDER THE PUBLIC UTILITIES DEPARTMENT.

CITY OF CLOVIS			CITY BACKFLOW PREVENTION DEVICE		DWG NO. W-18	
APPROVED BY:	NO.	REVISED	BY:	APPROVALS:	SCALE:	N.T.S.
CITY ENGINEER	01-19-11		BJG	CM	OTHER	DRAWN BY: JA
DATE:			DRU	OTHER		SHEET 1 OF 1

D DOMESTIC WATER BACKFLOW PREVENTION DEVICE
CX2.3 NOT TO SCALE

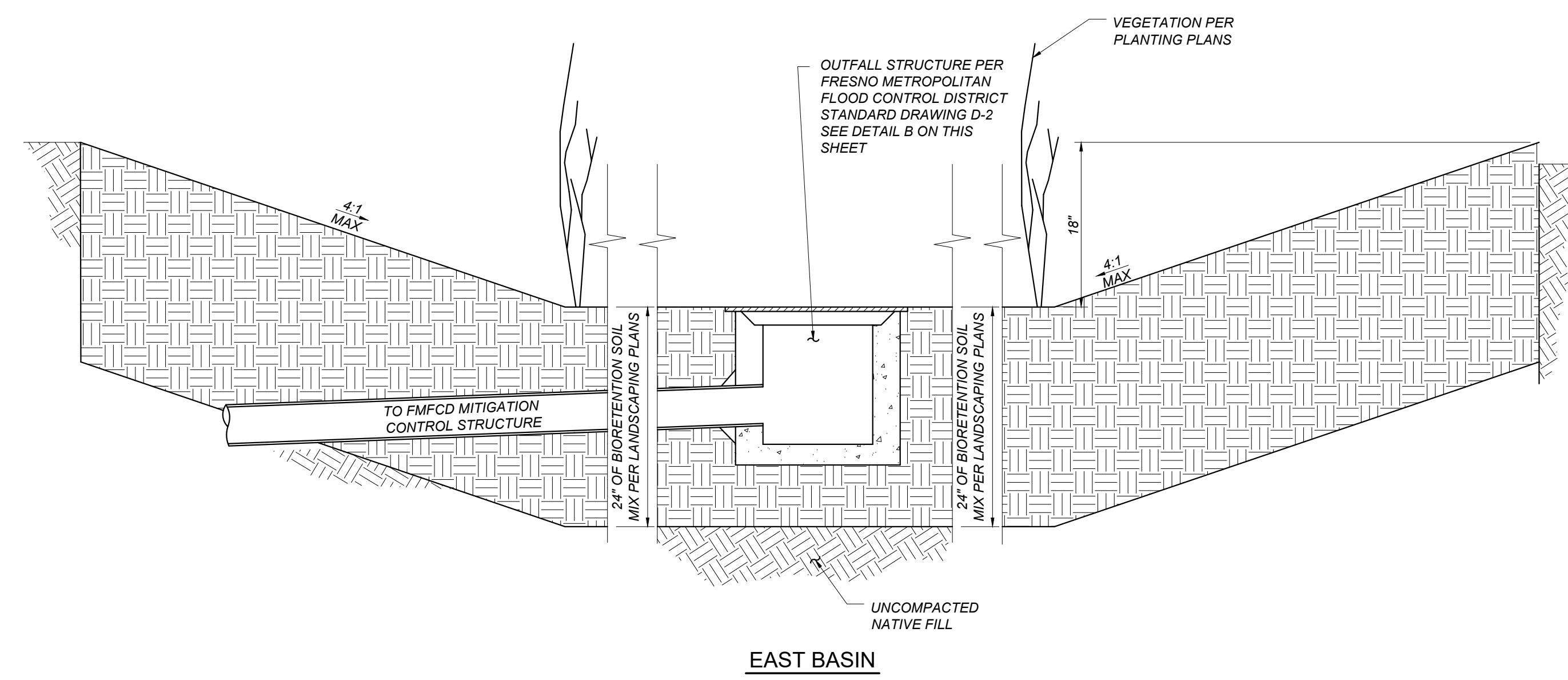
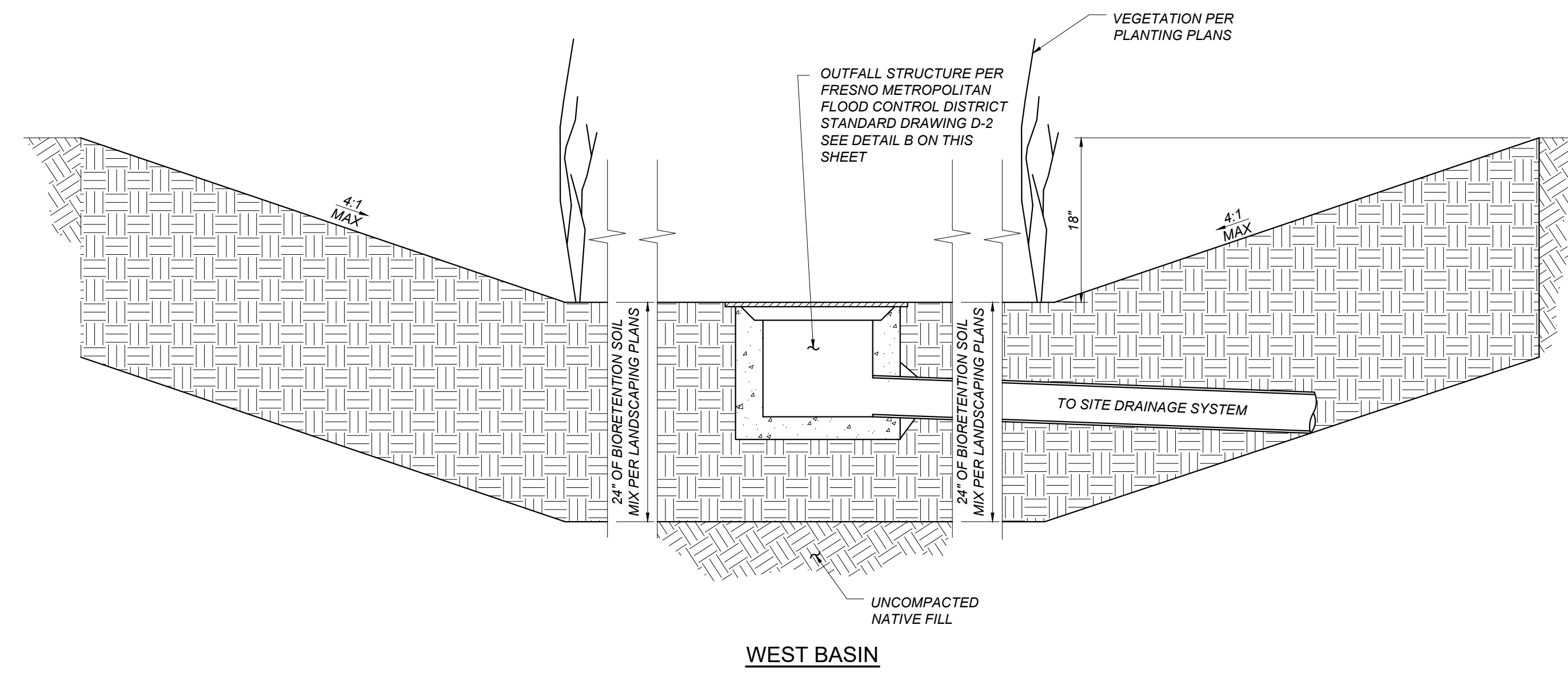

E BASIN SECTIONS
CX2.3 NOT TO SCALE

Blair, Church & Flynn
CONSULTING ENGINEERS
481 Clovis Avenue, Suite 200
Clovis, California 93612
Tel: (509) 328-1400
Fax: (509) 328-1800

ONLINE SCHOOL & SPECIAL EDUCATION
ADMINISTRATION DISTRICT OFFICE EXPANSION
CLOVIS UNIFIED SCHOOL DISTRICT
CLOVIS, CA
DRAWING TITLE
UTILITY DETAILS

PROJECT NO.
12242.00
DRAWING
CX2.3

MARK	DATE	DESCRIPTION	DSA BACKCHECK
A	10/26/23	ADDENDUM 5	07/17/23

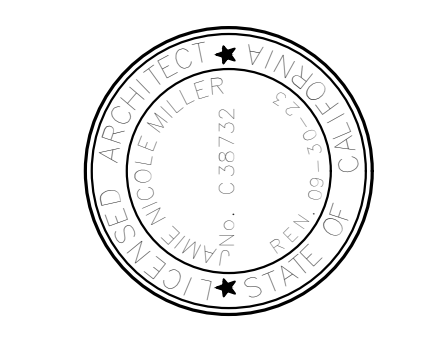

TETER, LLP
FRESNO HEADQUARTERS
VISALIA | BAKERSFIELD | MADERA | SAN LUIS OBISPO
ARCHITECTS ENGINEERS CONNECTED

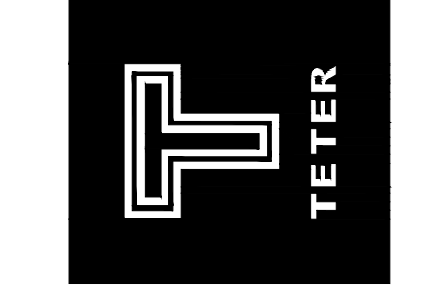

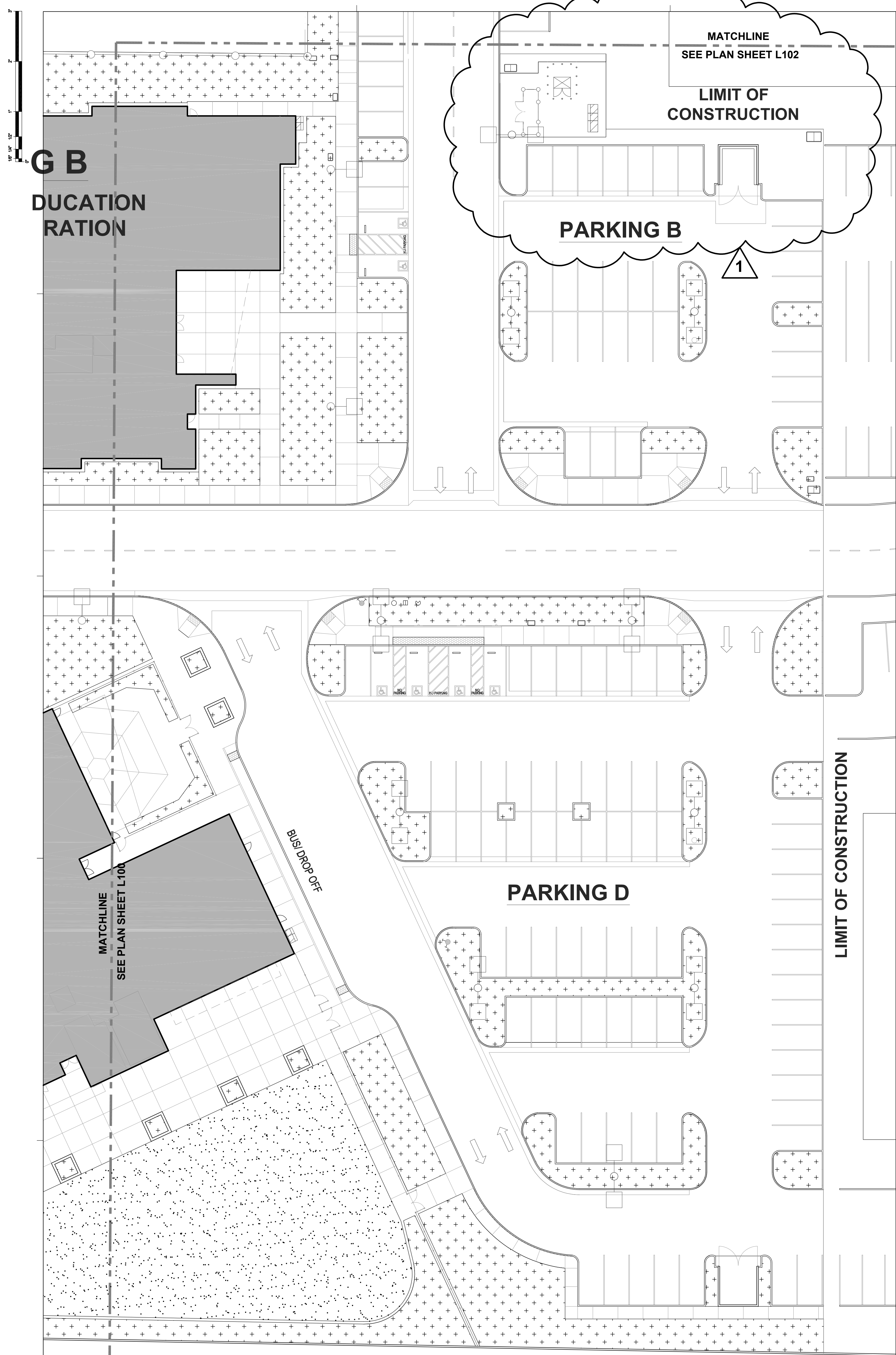

LANDSCAPE MULCHING LEGEND

SYMBOL	DESCRIPTION
	3" COMPACTED LAYER OF WALK ON BARK TOPDRESSING MULCH TO BE SUPPLIED BY SUPERIOR SOIL SUPPLIMENTS. TOPDRESSING MULCH TO BE PLACED IN ALL NON TURF LANDSCAPE AREAS. TOPDRESSING MULCH THICKNESS IS TO BE EVALUATED AT THE END OF MAINTENANCE PERIOD AND AREAS THAT DO NOT HAVE 3" COMPACTED THICKNESS ARE TO HAVE ADDITIONAL MULCH ADDED TO HAVE SPECIFIED DEPTH PRIOR TO PROJECT CLOSEOUT.
	3" LAYER OF SANTA FE (3/8" MINUS) DECOMPOSED GRANITE TOPDRESSING MULCH, COMPACTED THICKNESS AS SUPPLIED BY ROSENBALM ROCKERY, OR APPROVED EQUAL. CONTRACTOR IS TO INSTALL TOPDRESSING MULCH OVER JUTE MESH EROSION CONTROL FABRIC IN DESIGNATED SLOPED NON TURF PLANTER AREAS. CONTRACTOR IS TO INSTALL STANDARD JUTE MESH OVER ENTIRE AREA WITH SIX INCHES (6") OF OVERLAP BETWEEN COURSES. CONTRACTOR IS TO FASTEN JUTE MESH TO SLOPE WITH 9" LONG, 11 GAUGE STAPLES PLACED ON 12" CENTERS. CONTRACTOR IS TO INSTALL TOPDRESSING MULCH OVER THE JUTE MESH EROSION CONTROL FABRIC. PLANT MATERIAL DAMAGED BY CONSTRUCTION ACTIVITIES WILL BE REJECTED. CONTRACTOR IS TO MAINTAIN THE AREA WEED FREE AND REPAIR EROSION AREAS WEEKLY UNTIL FINAL ACCEPTANCE BY THE DISTRICT. SUBMIT DECOMPOSED GRANITE SAMPLES TO DISTRICT TO APPROVE MATERIAL TO BE INSTALLED. DECOMPOSED GRANITE IS TO BE TOP QUALITY AND OF THE HIGHEST GRADE. DECOMPOSED GRANITE AREAS ARE TO BE COMPACTED WITH A WATER DRUM ROLLER AND FINISHED GRADED PER THE SITE GRADING PLAN. DECOMPOSED GRANITE IS TO BE AT OPTIMUM MOISTURE CONTENT FOR COMPACTION WORK. SLOPPY OR LOOSE / LIGHTLY COMPACTED AREAS WILL BE REJECTED. TOPDRESSING MULCH THICKNESS IS TO BE EVALUATED AT THE END OF MAINTENANCE PERIOD AND AREAS THAT DO NOT HAVE 3" COMPACTED THICKNESS ARE TO HAVE ADDITIONAL MULCH ADDED TO HAVE SPECIFIED DEPTH PRIOR TO PROJECT CLOSEOUT. SEE INSTALLATION DETAIL #18 ON PLAN SHEET L401 FOR ADDITIONAL INFORMATION.
	3" LAYER OF SANTA FE (3/8" MINUS) DECOMPOSED GRANITE TOPDRESSING MULCH, COMPACTED THICKNESS AS SUPPLIED BY ROSENBALM ROCKERY, OR APPROVED EQUAL. SUBMIT SAMPLES TO DISTRICT TO APPROVE MATERIAL TO BE INSTALLED. DECOMPOSED GRANITE IS TO BE TOP QUALITY AND OF THE HIGHEST GRADE. DECOMPOSED GRANITE AREAS ARE TO BE COMPACTED WITH A WATER DRUM ROLLER AND FINISHED GRADED PER THE SITE GRADING PLAN. DECOMPOSED GRANITE IS TO BE AT OPTIMUM MOISTURE CONTENT FOR COMPACTION WORK. SLOPPY OR LOOSE / LIGHTLY COMPACTED AREAS WILL BE REJECTED. SEE INSTALLATION DETAIL #18 ON PLAN SHEET L401 FOR ADDITIONAL INFORMATION.
	TURF GRASS - TIFWAY 419 HYBRID BERMUDAGRASS SOD AS SUPPLIED BY AG SOD, ALEC LEMAY, (559) 289-6381, OR APPROVED EQUAL. SEE SPECIFICATIONS.
	4" MINIMUM LAYER OF WASHED "COBBLE" MULCH AS SUPPLIED BY ROSENBALM'S ROCKERY, (559) 256-3900, LOCATED IN FRESNO, CALIFORNIA OR APPROVED EQUAL. CONTRACTOR IS TO EVENLY PLACE 4" X 8" COBBLE OVER ONE HALF (1/2) OF THE DESIGNATED AREA. CONTRACTOR IS TO PLACE 2" X 4" COBBLE OVER THE REMAINING ONE HALF (1/2) OF THE DESIGNATED AREA TO COMPLETELY COVER THE AREA WITH A MINIMUM DEPTH OF 4" OF COBBLE MULCH. INFILL REMAINING VOIDS WITH 1" X 2" SUNBURST COBBLE. CONTRACTOR TO FIELD VERIFY.
	CONTRACTOR IS TO PREPARE THE SUB-GRADE FOR THE GRAVEL MULCH WITH AN APPLICATION OF AN APPROVED, LONG LASTING, GRANULAR PRE-EMERGENT JUST PRIOR TO THE PLACEMENT OF THE GRAVEL MULCH AT LABEL RATES. CONTRACTOR IS TO REAPPLY (SURFACE BROADCAST) A SECOND APPLICATION AT THE END OF THE SPECIFIED MAINTENANCE PERIOD. TWO (2) APPLICATIONS REQUIRED FOR BID. CONTRACTOR IS TO MAINTAIN THE AREA WEED FREE AND REPAIR EROSION AREAS WEEKLY UNTIL FINAL ACCEPTANCE BY THE DISTRICT.
	UTILITY EASEMENT: NO TREES ARE ALLOWED TO BE PLANTED WITHIN THE UTILITY EASEMENT CORRIDOR. CONTRACTOR IS TO TAKE PRECAUTIONS AS REQUIRED WHEN TRENCHING IN THESE AREAS TO LOCATE EXISTING UTILITIES PRIOR TO WORKING IN THESE AREAS. CONTRACTOR IS TO TAKE ALL REASONABLE MEANS TO FIELD LOCATE EXISTING UTILITIES.
	NATURAL WEATHERED GRANITE BOULDERS. EACH BOULDER SYMBOL REPRESENTS 1.5 TONS OF BOULDERS. AN AREA WITH THREE BOULDER SYMBOLS IS TO RECEIVE A 4.5 TON SETTING OF BOULDERS. BOULDERS ARE TO BE SET IN NATURAL POSITIONS WITH UP TO ONE THIRD OF THE BOULDER VOLUME SUBMERGED BELOW GRADE. CONTRACTOR IS TO WORK WITH LANDSCAPE ARCHITECT TO CREATE ATTRACTIVE BOULDER SETTINGS THAT ARE AESTHETICALLY PLEASING. SMALLEST BOULDER SIZE IS 0.5-0.75 TONS. LARGEST BOULDER SIZE IS 2.5 TONS. BOULDERS ARE TO BE AN ASSORTMENT OF SIZES AND SHAPES OF NATURALLY WEATHERED GRANITE. BOULDERS THAT ARE NOT ATTRACTIVE IN APPEARANCE WILL BE REJECTED. BOULDERS WITH EXCESSIVE SCRAPES, SCRATCHES OR NON NATURAL MARKS WILL BE REJECTED. BOULDERS NOT SET PROPERLY IN A NATURAL SETTING WILL BE REJECTED. BOULDER SYMBOLS ARE DIAGRAMMATIC AND THE FINAL BOULDER LOCATIONS WILL BE DETERMINED IN THE FIELD. BOULDERS ARE TO BE PLACED AND INSTALLED AFTER THE SITE ROUGH GRADING HAS BEEN COMPLETED AND APPROVED AND PRIOR TO THE INSTALLATION OF IRRIGATION AND PLANTING IMPROVEMENTS. CONTRACTOR IS TO USE NATIVE SOIL TO FILL BEHIND (UPHILL SIDE) OF BOULDERS TO SOFTEN GRADES FOR TREES AND LARGE SHRUBS. GRADING IS TO BE ATTRACTIVE, ADD VISUAL INTEREST AND EMPHASIZE THE BOULDERS. SEE "COBBLE" LEGEND ITEM FOR ADDITIONAL INFORMATION. IRRIGATION AND PLANTS MAY MOVE BASED UPON THE FINAL BOULDER INSTALLATION LOCATIONS (ESPECIALLY ROCK PLANTS). CONTRACTOR IS TO WORK WITH THE LANDSCAPE ARCHITECT TO ASSESS THE BOULDERS FOR USE ON THE PROJECT. ONLY QUALITY AND ATTRACTIVE BOULDERS WILL BE ALLOWED FOR USE ON THE PROJECT. THE BOULDER SIZE MUST BE APPROPRIATE FOR THE INSTALLATION LOCATION. CONTRACTOR IS TO REMOVE NON-CONFORMING BOULDERS FROM THE PROJECT AT NO ADDITIONAL EXPENSE TO THE DISTRICT. ALL BOULDER LOCATIONS AND INSTALLATION ORIENTATION ARE TO BE APPROVED BY THE LANDSCAPE ARCHITECT IN THE FIELD. SEE INSTALLATION DETAIL #21 ON PLAN SHEET L401 FOR ADDITIONAL INFORMATION.
	TOPDRESSING MULCH INSTALLATION NOTE: PERIMETER "LOCK TRENCH" FOR TOPDRESSING MULCH AREAS - CONTRACTOR IS TO LOWER THE EXISTING GRADE AT ALL PERIMETER AREAS WHERE DESIGNATED TOPDRESSING MULCH AREAS ARE ADJACENT TO PERIMETER CURB, SIDEWALK OR UTILITY VAULTS OR ANY OTHER HARDSCAPED SURFACE. DECOMPOSED GRANITE AREAS (3") BELOW THE TOP OF ADJACENT HARDSCAPE SURFACE OVER ONE FOOT (1'-0" WIDTH) AND THEN TAPER TO EXISTING GRADE IN A GENTLE MANNER OVER A ONE TO TWO FOOT AREA (1'-0" - 2'-0") AS REQUIRED. WALK ON BARK AREAS (3") BELOW THE TOP OF ADJACENT HARDSCAPE SURFACE OVER ONE FOOT (1'-0" WIDTH) AND THEN TAPER TO EXISTING GRADE IN A GENTLE MANNER OVER A ONE TO TWO FOOT AREA (1'-0" - 2'-0") AS REQUIRED. EDGE GRADING WORK IS TO "LOCK" THE TOPDRESSING MULCH IN PLACE TO ELIMINATE MULCH MIGRATION AND LOSS. CONTRACTOR IS TO REMOVE "LOCK TRENCH" SPOILS AND EXTRA SOIL OFF SITE AS PART OF THE BID OR INCORPORATE INTO SITE GRADING. CONTRACTOR IS TO FIELD VERIFY. SEE INSTALLATION DETAIL #20 ON PLAN SHEET L401 FOR ADDITIONAL INFORMATION.

TETER, LLP expressly reserves its common law copyright and other rights in this document. The drawings, text, and designs incorporated herein, as an instrument of professional service, are made a part of, for any other project without prior written authorization.

10/25/23	ADDENDUM NO. 5
MARK	DATE
	DESCRIPTION
	9/2/23
	DSA BACK CHECK

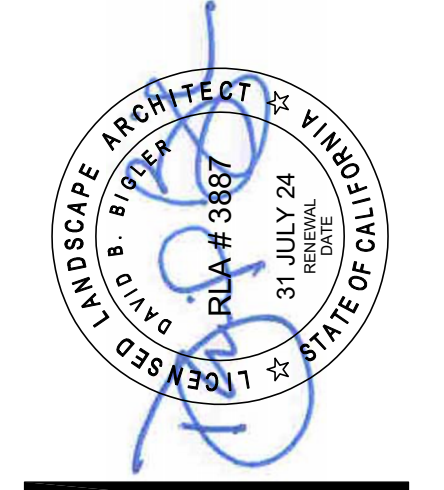

TETER, LLP
 FRESNO HEADQUARTERS
 1530 N. BAKER ST. #100
 FRESNO, CA 93704
 31 JULY 24
 LANDSCAPE ARCHITECT #3887
 ARCHITECTS ENGINEERS CONNECTED

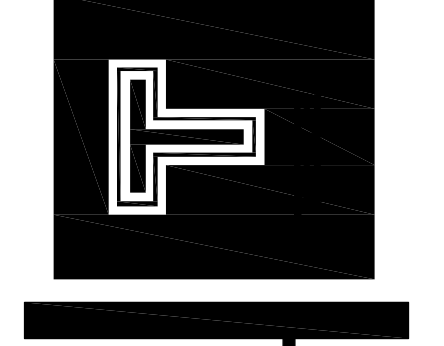

ONLINE SCHOOL & SPECIAL EDUCATION
 ADMINISTRATION DISTRICT OFFICE EXPANSION
 CLOVIS UNIFIED SCHOOL DISTRICT
 CLOVIS, CA
 DRAWING TITLE
 LANDSCAPE MULCHING PLAN

PLOT DATE:

LANDSCAPE MULCHING PLAN

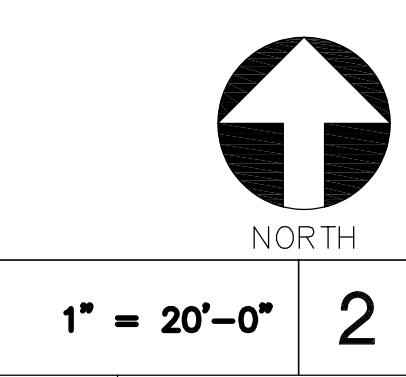

David Bigler Associates
 Landscape Architect #3887
 516 W. Shaw Avenue
 Fresno, California 93704
 E-Mail: davidbigler@dba.com
 Tel: (559) 276-9485
 Fax: (559) 276-9487

PROJECT NO.
 12242.00
 DRAWING
 L101

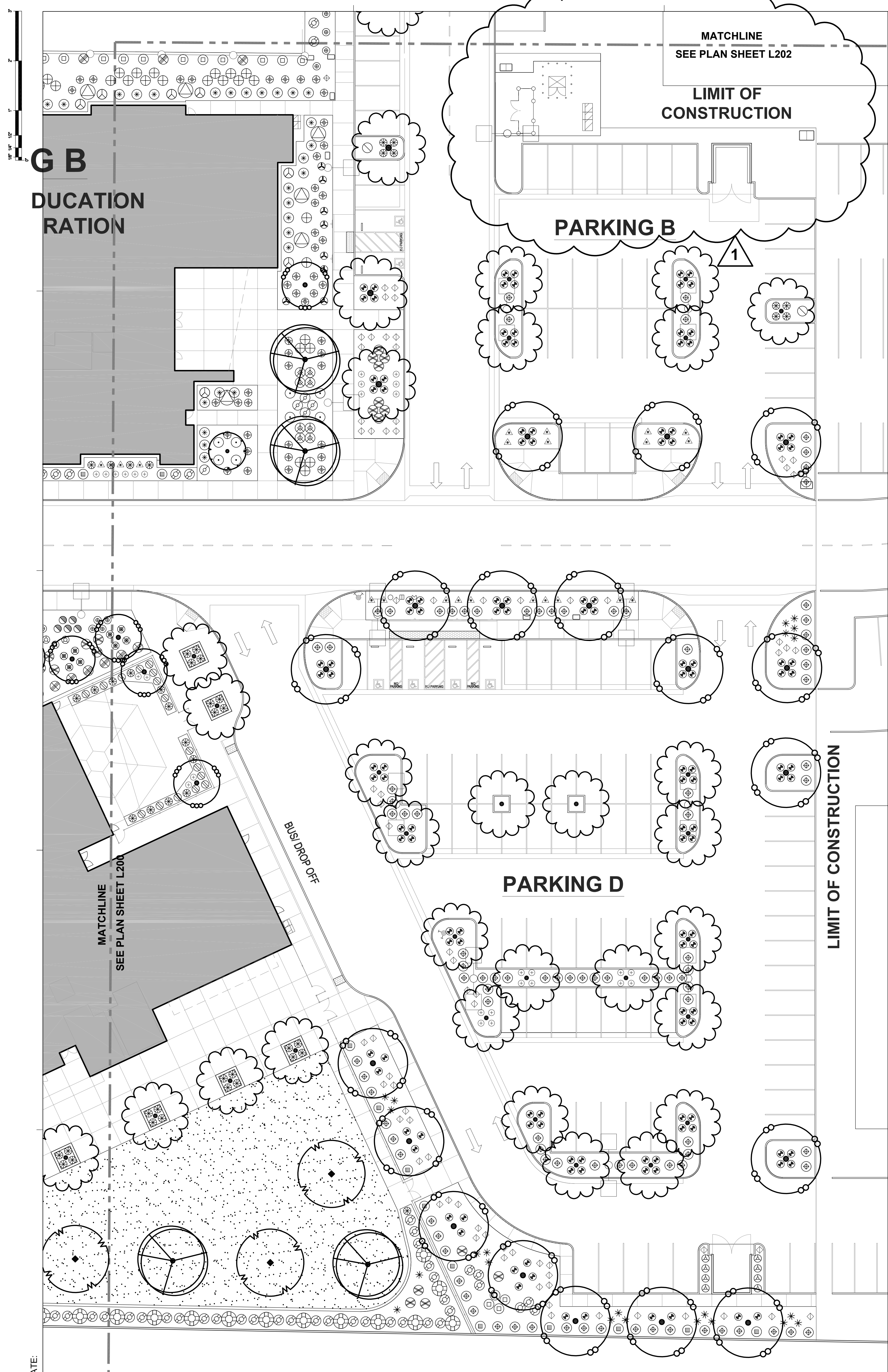

LANDSCAPE PLANTING LEGEND

SYMBOL	SIZE	WATER USE	DESCRIPTION
	5 Gal	Low	HESPERALOE parviflora 'Desert Flamenco', Desert Flamenco Red Yucca.
	5 Gal	Low	HESPERALOE parviflora 'Perpa', Brakelights Red Yucca.
	1 Gal	Low	LANTANA camara 'Bandana Pink', Pink Bandana Lantana.
	1 Gal	Low	TEUCRIUM cossoni, Gray Creeping Germander.
	1 Gal	Low	LANTANA montevidensis 'Trailing Lavender', Lavender Lantana.
	1 Gal	Low	BULBINE frutescens 'Tiny Tangerine', Dwarf Orange Bulbine.
	5 Gal	Low	LEUCOPHYLLUM zygophyllum 'Cimarron', Blue Ranger.
	1 Gal	Mod	DIANELLA caerulea 'Cassa Blue', Cassa Blue Flax.
	1 Gal	Low	DIETES iridioides 'Lemon Drops', Hybrid Fortnight Lily.
	1 Gal	Low	DIANELLA revoluta 'Little Rev', Little Rev Flax.
	5 Gal	Mod	BERBERIS thunbergii atropurpurea 'Crimson Pygmy', Dwarf Japanese Barberry.
	5 Gal	Low	NANDINA domestica 'Gulf Stream', Heavenly Bamboo.
	5 Gal	Low	LAVANDULA angustifolia 'Munstead', English Lavender.
	5 Gal	Low	ERIGERON karvinskianus, Santa Barbara Daisy.
	5 Gal	Low	SALVIA greggii 'Hot Lips', Desert Salvia.
	1 Gal	Low	LANTANA 'Lemon Zest', Yellow Bandana Lantana.
	1 Gal	Low	MUHLENBERGIA dubia, Pine Muhly.
	1 Gal	Low	MUHLENBERGIA capillaris 'Regal Mist', Regal Mist Grass.
	5 Gal	Mod	BERBERIS thunbergii 'Rose Glow', Rose Glow Barberry.
	5 Gal	Mod	SPIRAEA bumalda 'Neon Flash', Neon Flash Spiraea.
	5 Gal	Mod	PITOSPORUM tobira 'Varigata', Variegated Tobira.
	5 Gal	Low	RHAPHIOLEPIS umbellata 'Minor', Yeddo Hawthorn.
	5 Gal	Mod	LOROPETALUM chinense 'Burgundy', Loropetalum.
	5 Gal	Low	LEUCOPHYLLUM frutescens 'Compacta', Texas Ranger.
	5 Gal	Mod	COLEONEMA pulchellum 'Sunset Gold', Sunset Gold Breath of Heaven.
	5 Gal	Mod	RHAPHIOLEPIS indica 'Enchantress', Indian Hawthorn.
	5 Gal	Low	CAESALPINIA pulcherrima, Red Bird of Paradise.
	5 Gal	Low	CALLISTEMON viminalis 'Little John', Dwarf Bottle Brush.
	5 Gal	Low	TECOMA x 'Solar Flare', Solar Flare Tecoma.
	5 Gal	Low	RUSSELIA x 'St. Elmo's Fire', Red Russelia.
	5 Gal	Low	CISTUS 'Sunset', Sunset Rock Rose.
	5 Gal	Low	ACACIA redolens 'Desert Carpet', Prostrate Acacia.
	15 Gal	Low	CUPRESSUS arizonica glabra 'Blue Ice', Smooth Arizona Cypress, Columnar Form.
	15 Gal	Mod	MAGNOLIA soulagiana 'Alexandrina', Saucer Magnolia, Multi Trunk Form.
	15 Gal	Low	LAGERSTROEMIA 'Dynamite', Red Crape Myrtle Shrub.
	15 Gal	Low	COTINUS cogglyria 'Royal Purple', Smoke Tree, multi trunk form.
	24" Box	Mod	ACER palmatum 'Sango Kaku', Coral Bark Maple Tree, Multi Trunk or Low Branch Form.
	24" Box	Mod	CERCIS canadensis texensis 'Oklahoma', Oklahoma Redbud, Standard form.
	24" Box	Mod	GINKGO biloba 'Princeton Sentry', Princeton Sentry Ginkgo Tree, Low Branch Form.
	15 Gal	Low	CERCIDIUM x 'Desert Museum', Desert Museum Palo Verde Tree, Multi Trunk or Low Branch Form.
	15 Gal	Low	PISTACIA x 'Red Push', Red Push Pistache Tree, standard form.
	15 Gal	Low	LAURUS nobilis 'Saratoga', Bay Tree, standard form.
	15 Gal	Low	PISTACIA chinensis 'Keith Davey', Chinese Pistache Tree, standard form.
	15 Gal	Mod	QUERCUS virginiana, Southern Live Oak Tree, standard form.
	15 Gal	Mod	ACER rubrum 'October Glory', October Glory Maple Tree, standard form.
	1 Gal	Low	CAREX divulsa, Berkeley Sage. Install 3'-0" on center in a triangular pattern to fill designated areas.

SEE PARKING LOT SHADING CALCULATIONS ON PLAN SHEET L202

SEE TREE & SHRUB PLANTING DETAIL #23 ON PLAN SHEET L401

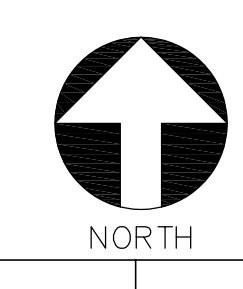

David Bigler Associates
 Landscape Architect #3887
 518 W. Shaw Avenue
 Fresno, California 93704
 E Mail: davidbigler@dba.com
 Tel: (559) 276-9485
 Fax: (559) 276-9487

ONLINE SCHOOL & SPECIAL EDUCATION ADMINISTRATION DISTRICT OFFICE EXPANSION CLOVIS UNIFIED SCHOOL DISTRICT

LANDSCAPE PLANTING PLAN

PROJECT NO. 12242.00

DRAWING L201

DATE: 9/2/123

DESCRIPTION: DSA BACK CHECK

ADDENDUM NO. 5

10/25/23

TETER, LLP ARCHITECTS ENGINEERS CONNECTED

FRESNO HEADQUARTERS VISALIA | BAKERSFIELD | MODESTO | SAN LUIS OBISPO

31 JULY 24

PLANS 3887

REGISTERED ARCHITECT #3887

REGISTERED ENGINEER #3887

REGISTERED LANDSCAPE ARCHITECT #3887

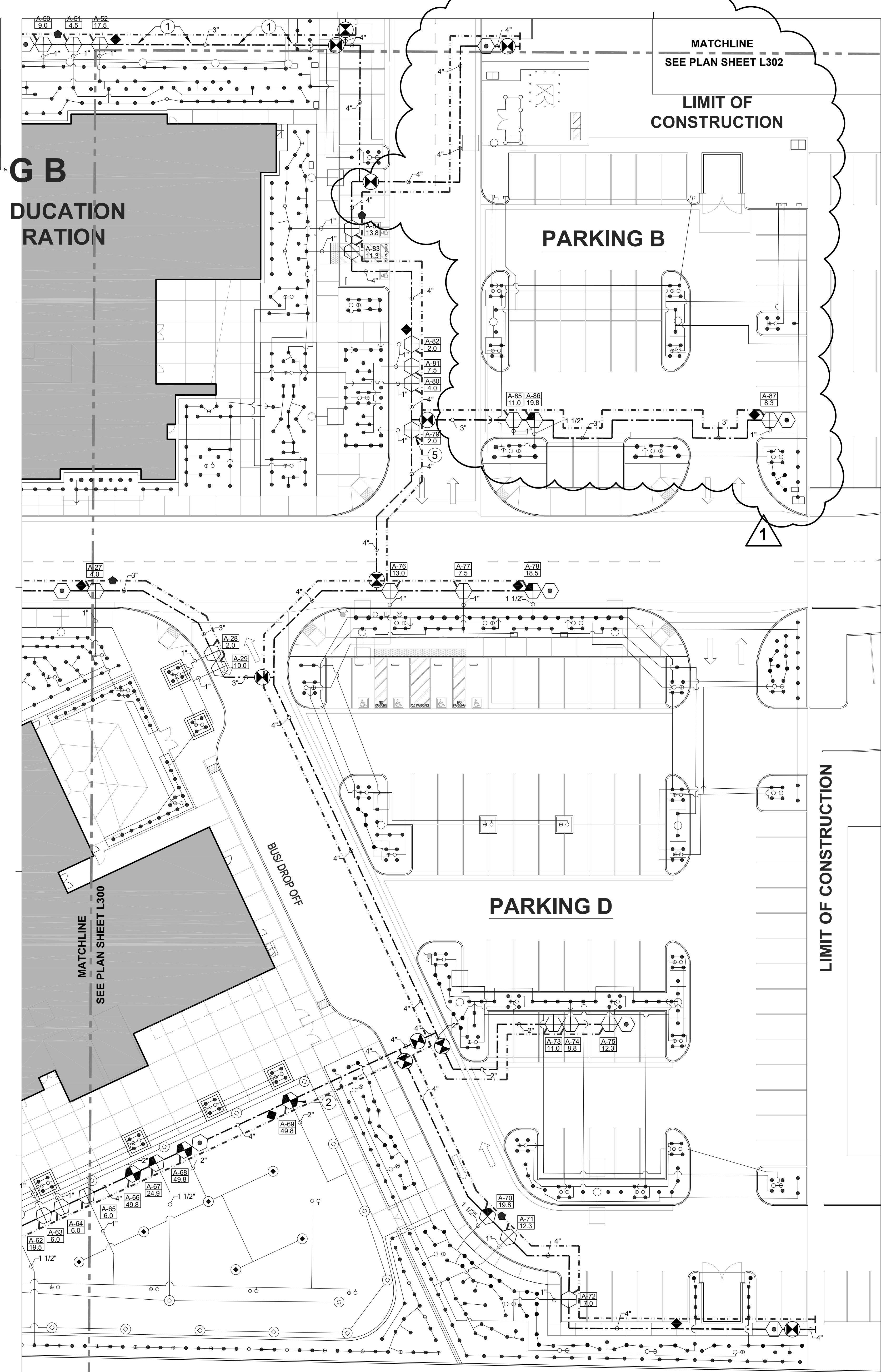

LANDSCAPE IRRIGATION LEGEND

SYMBOL	DESCRIPTION	SYMBOL	DESCRIPTION
○	Rainbird #1804-SAM-PRS, 4" Pop-up Sprinkler with pressure regulation and check valve with Hunter PC Multi Stream Bubbler Nozzle (1/2" inlet: 0.5 gpm @ 30 psi). Install on uphill side of plant or tree. Install 24 inches from center of tree location. See Installation Detail #01 on Plan Sheet L400 for additional information.	A	Rainmaster Laguna #DXI-SPEDTW-LAGUNA, 200 Station DXi 2-Wire / Decoder Irrigation Controller with #SPED locking Stainless Steel Pedestal, ethernet ready. DXi Laguna 2-Wire controller that is network ready via ethernet card. Campus network connection for internet access is via (CAT-6) network cable installed to irrigation controller location by Site Electrical / Data Electrical Plans. See Installation Details #17 and #19 on Plan Sheet L401 and Installation Detail #27 on Plan Sheet L402 for additional information.
●	Rainbird #1804-SAM-PRS, 4" Pop-up Sprinkler with pressure regulation and check valve with Hunter PC Multi Stream Bubbler Nozzle (1/2" inlet: 0.25 gpm @ 30 psi). Install on uphill side of plant or tree. See Installation Detail #01 on Plan Sheet L400 for additional information.	NOT SHOWN	Rainmaster Laguna Central Control System: Contractor is responsible for all data collection, data input and programming for a complete installation in compliance with the manufacturers recommendations for active weather control of the irrigation system on District computer. Contractor is to assist and train up to six (6) designated District Maintenance staff in the programming and operation of the irrigation controller and Rainmaster Laguna Central Control System with remote maintenance access from the Rainmaster PROMAX remote radio system and from the existing cellular smart phones of the District Maintenance Staff.
⊕	Rainbird #RWS-B-C-1402 with #1402 (0.5 gpm) bubbler Root Watering System. Install on uphill side of plant or tree. Install 24 inches from center of tree location. See Installation Detail #07 on Plan Sheet L400 for additional information.	NOT SHOWN	Provide two (2) Rainmaster #PROMAX remote radio kits for remote access to the irrigation controllers and Laguna Central Irrigation Controller system to the District.
⊕	Hunter # I-20-12-03, 12" pop up I-20 Series Rotor Sprinkler with part / full circle arcs, plastic riser and check valve with #3.0 nozzle. (3/4" inlet: 3.0 gpm @ 45 psi). See Installation Detail #03 on plan sheet L400 for additional information.	A MV	Irrigation Controller Designation Controller Master Valve Input
⊕	Hunter # I-25-06-SS-08, 6" pop up I-25 Series Rotor Sprinkler with part / full circle arcs, stainless steel riser and check valve with #8.0 nozzle. (1" inlet: 8.3 gpm @ 50 psi). See Installation Detail #02 on plan sheet L400 for additional information.	A FS	Irrigation Controller Designation Controller Flow Sensor Input
⊕	1" Irritrol # 100P1.0, 100 Plus Series Electric Remote Control Valve. Contractor is to install a maximum of one valve per valve box. Inlet pipe is to be the same size as the outlet pipe noted on the plan. Contractor is to install line size filter on all pop up spray sprinkler and low flow pop up bubbler valves in separate valve box adjacent to each other. Filters are to be installed on discharge side of valve. See Installation Detail #30 on Plan Sheet L403 for additional information.	A-06 9.0	Controller # / Station # Gallons per minute
⊕	1 1/2" Irritrol # 100P1.5, 100 Plus Series Electric Remote Control Valve. Contractor is to install a maximum of one valve per valve box. Inlet pipe is to be the same size as the outlet pipe noted on the plan. Contractor is to install line size filter on all pop up spray sprinkler and low flow pop up bubbler valves in separate valve box adjacent to each other. Filters are to be installed on discharge side of valve. See Installation Detail #31 on Plan Sheet L403 for additional information.	PMP 01	Irrigation Booster Pump: Watertronics #WMBV-5000-7A-15-480-3-220-75, Irrigation booster pump capable of 220 gpm at 60 - 70 psi boost with a minimum dynamic inlet pressure of 15 psi. Pump station is to feature VFD controls with a regulated set point discharge pressure of 75 psi. Pressure set point may be adjusted within a 10 psi range by user input. Pump station is to have a marine grade aluminum enclosure and base, unpainted painted installed on a 8" thick concrete slab with #4 rebar reinforcement installed in a 12 inch (12") square grid. Pump station concrete slab is to be a minimum of 12" larger than the pump station enclosure footprint on each side. See Installation Detail #24 on Plan Sheet L402 for additional information.
⊕	2" Irritrol # 100P2.0, 100 Plus Series Electric Remote Control Valve. Contractor is to install a maximum of one valve per valve box. Inlet pipe is to be the same size as the outlet pipe noted on the plan. Contractor is to install line size filter on all pop up spray sprinkler and low flow pop up bubbler valves in separate valve box adjacent to each other. Filters are to be installed on discharge side of valve. See Installation Detail #32 on Plan Sheet L403 for additional information.	BFP 01	4" Irrigation Reduced Pressure Backflow Prevention Device to be installed by Site Utility Contractor, see Site Civil / Utility Plan. Landscape Contractor to coordinate all work as required. See Site Civil Plans.
◆	Rainbird 44LRC, Quick Coupling Valve. Provide District with five (5) quick coupler keys with hose swivels. Install in separate 10" round valve box. See Installation Detail #10 on Plan Sheet L400 for additional information.	F	3" FLOMEC #QS200-30 Ultra Sonic Flowmeter with PVC Tee. Contractor is to install Rainmaster #TW-CAB-14, 2-Wire communication cable installed in 1 1/2" PVC electrical conduit between the Flowmeter vault and the Irrigation Controller 'A' with DXi AC 2-Wire Flow Sensor Decoder #TW-DAC-FLOW. Install per manufacturers recommendations and make all wire splices with Rainmaster #TW-SPLICE-14 waterproof splice kits. Flowmeter is to have an output signal compatible with Rainmaster DXi Laguna Irrigation Controller System. See Installation Detail #29 on Plan Sheet L402 for additional information.
⊕	1" Crispin #C-10, Air and Vacuum Release Valve to be installed at high points and dead end runs of the mainline piping system. Install in a standard rectangular valve box. Contractor to field locate. See Installation Detail #13 on Plan Sheet L400 for additional information.	M	4" Bermad #IR-4"-410-G-I-A1-PG-4RO-CB-XZ, Solenoid Controlled Irrigation Master Valve with flange ends, normally open. Contractor is to install with Rainmaster Decoder #TW-D-1, one station decoder for Master Valve on 2-Wire path between master valve and Controller 'A'. Contractor is to install Rainmaster two wire path #TW-CAB-14 communication cable installed in 1 1/2" PVC electrical conduit between the Master Valve vault and the Irrigation Controller 'A'. Install per manufacturers recommendations and make all wire splices with Rainmaster #TW-SPLICE-14 waterproof splice kits. Master Valve is to have a solenoid compatible with Rainmaster DXi Laguna Irrigation Controller System. See Installation Detail #28 on Plan Sheet L402 for additional information.
⊕	2" thru 3": Nibco #T-113 IRR BHW, Bronze Gate Valve with Non-Rising Stem. 4": Nibco #P619-RW, Resilient Seat Gasketed Joint Gate Valve, 200 psi. Gate Valves are to be line size and installed in a 10" round valve box. Provide two (2) square operating nut handles (4" min. length) or each type required to the District. See Installation Details #08 & #09 on Plan Sheet L400 for additional information.	IRRIGATION COMMUNICATION CABLE: RAINMASTER 2-WIRE COMMUNICATION CABLE #TW-CAB-14 (Black & Red) installed in 1 1/2" PVC Schedule 40 Electrical conduit with sweep ells into all valve boxes with junction boxes located every one hundred fifty feet (150'), at all changes in direction and at all splices and dead end stubs for future extension. Junction boxes are to be heavy duty 12" standard rectangular valve boxes with locking covers except for splices made in remote control valve boxes. All decoder splices are to be located in valve box with remote control valves, or in junction boxes (12" standard rectangular valve box) where splices are required away from remote control valve boxes. All splices not related to a valve decoder are to be labeled on As-Built Plans. All 2-Wire splices are to be made with RainMaster #TW-SPLICE-14 waterproof splice kits. See Installation Details #04, #05 & #12 on Plan Sheet L400, Details #28 & #29 on Plan Sheet L402 and Details #30, #31, #32 & #33 on Plan Sheet L404.	
---	2" thru 3" PVC Schedule 40 SW Mainline Pipe. Mainline pipe fittings are to be PVC Schedule 80 solvent weld or threaded fittings or nipples.	POC	Rainmaster #TW-LA-1 Line Surge Protector, Two Wire Path Grounding. See Installation Detail #04 on Plan Sheet L400 for additional information.
---	4" PVC Class 200 Gasketed Mainline Pipe. Mainline pipe fittings are to be ductile iron Leemco gasketed fittings or Romac #202NS service saddle with double stainless steel straps, except where the irrigation details call for a specific fitting.		
	Size Mainline Piping as noted on the plan. Install all pipe in strict accordance with manufacturers instructions. For mainlines 3" and larger install concrete thrust blocks at all changes in direction. No bending, or curving of the pipe will be allowed, except as permitted by the pipe manufacturer. Pipe manufacturer must be approved prior to installation. Use mechanical joint restraints where concrete thrust blocks are not applicable, such as vertical changes in direction, or when two pipelines are side by side. See Installation Details #12 & #15 on Plan Sheet L400 & Detail #22 on Plan Sheet L401 for additional information.		

LANDSCAPE IRRIGATION KEY NOTES

- ① INSTALL IRRIGATION MAINLINE ON DISTRICT PROPERTY. MAINLINE SHOWN IS DIAGRAMMATIC FOR CLARITY.

PLOT DATE:

LANDSCAPE IRRIGATION PLAN

NORTH

1" = 20'-0" 8

David Bigler Associates
Landscape Architect #3887
518 W. Shaw Avenue
Fresno, California 93704
E Mail: davidbigler@dba.com
Tel: (509) 276-9485
Fax: (509) 276-9487

ONLINE SCHOOL & SPECIAL EDUCATION
 ADMINISTRATION DISTRICT OFFICE EXPANSION
 CLOVIS UNIFIED SCHOOL DISTRICT
 CLOVIS, CA
 DRAWING TITLE
 LANDSCAPE IRRIGATION PLAN

PROJECT NO.
 12242.00
 DRAWING
 L301

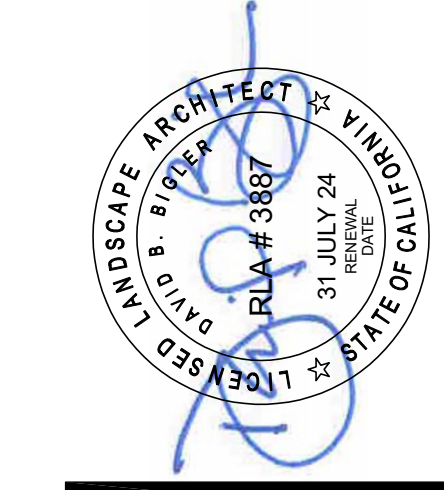

TETER, LLP
 FRESNO HEADQUARTERS
 VSALVA | BAKERSFIELD | MODESTO | SALINAS | CRISFPO
 ARCHITECTS ENGINEERS CONNECTED

MARK	DATE
1	9/21/23
ADDENDUM NO. 5	DESCRIPTION
	DSA BACK CHECK

Teter, LLP expressly reserves its common law copyright and other rights in the design, drawings, and designs herein and designs incorporated herein, as an instrument of professional service, and no part of any other project without prior written authorization.

PLOT DATE: _____

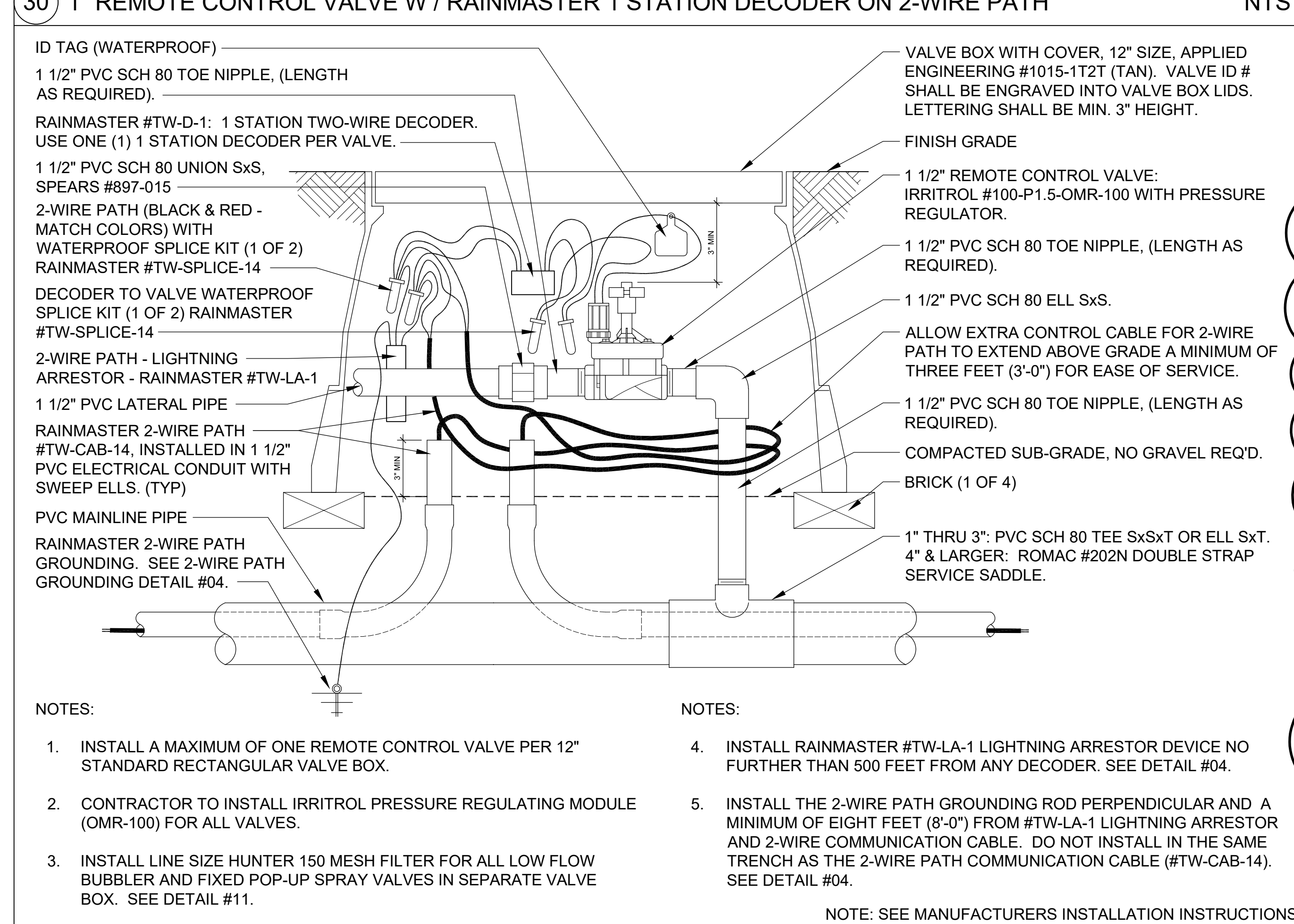
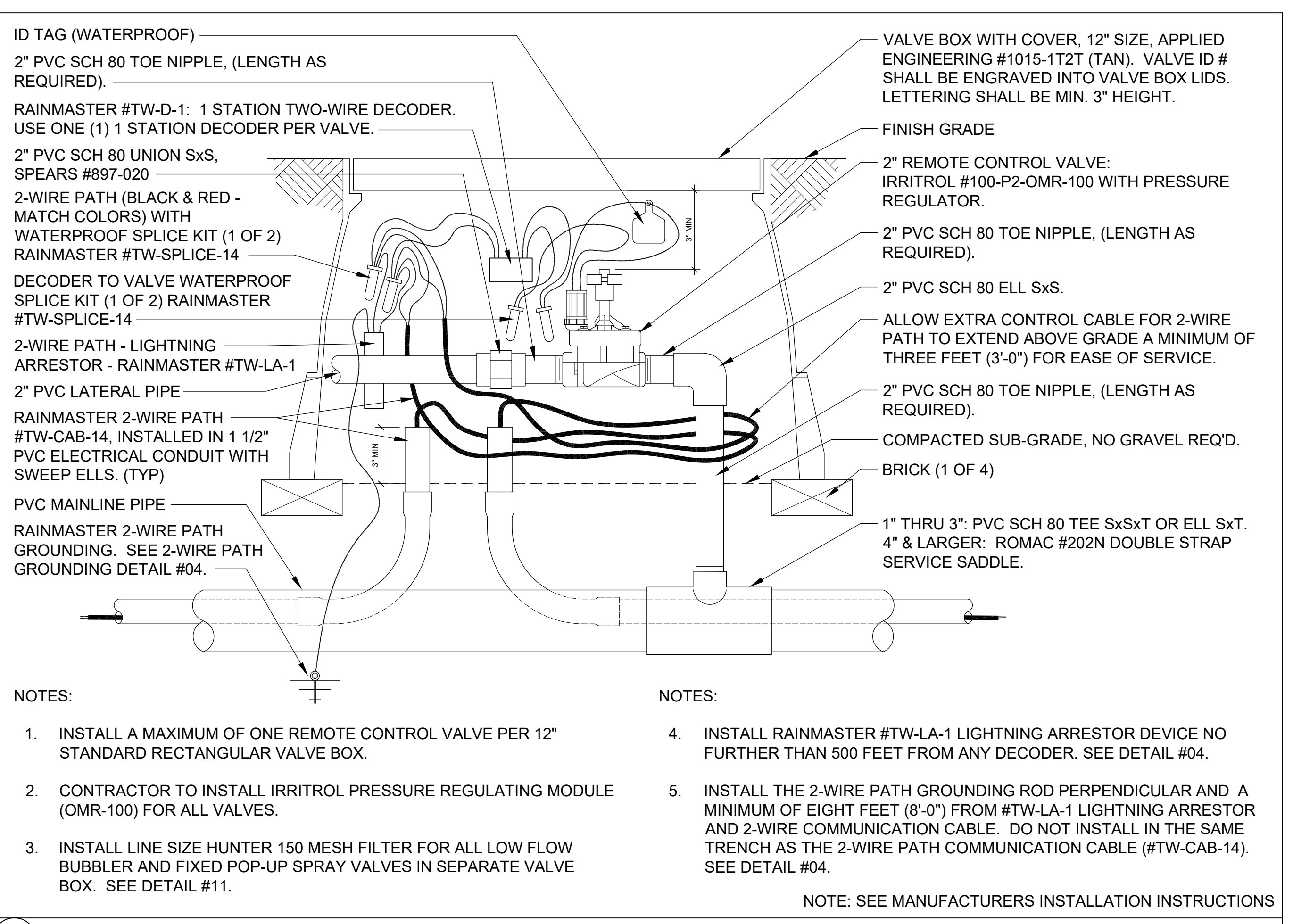
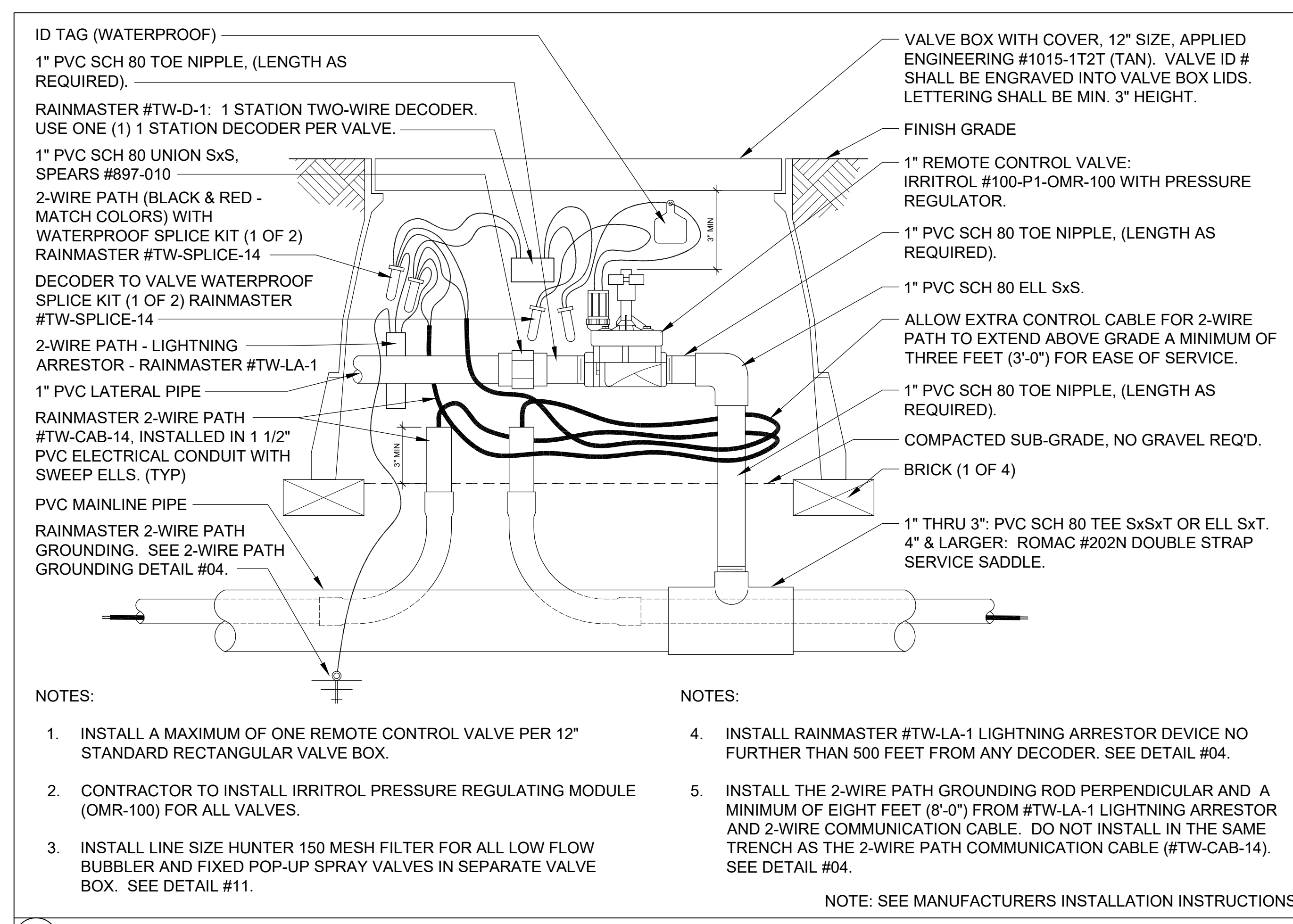

TWO-WIRE PATH & STATION DECODER NOTES

- ALWAYS INSTALL THE DECODER MODULE IN A VALVE BOX FOR EASE OF SERVICE.
- MAXIMUM COMMUNICATION WIRE LENGTH BETWEEN THE CONTROLLER AND THE FARTHEST DECODER IS 5,000 FEET.
- RECOMMENDED CABLE FOR CONTROLLER-TO-DECODER IS RAIN MASTER TWO-WIRE PATH, #TW-CAB-14, 14 AWG, SOLID COPPER, DOUBLE JACKETED 2-CONDUCTOR, DIRECT BURIAL CABLE. ALL 2-WIRE PATH CABLE IS TO BE INSTALLED IN 1 1/2" PVC ELECTRICAL CONDUIT WITH SWEEP ELLS.
- THE INTEGRITY OF THE COMMUNICATION CABLE IS CRITICAL TO OPERATION OF THE SYSTEM, AS IT IS BEING INSTALLED, BEFORE THE DECODERS ARE CONNECTED, LOOP THE COMMUNICATION CABLE UP OUT THE VALVE BOX LEAVING A MINIMUM 3 FT LOOP ABOVE GRADE.
- AT THE END OF EACH WIRE PATH, THE WIRE SHOULD BE TESTED WITH A VOLT-OHM METER TO CHECK FOR DAMAGE THAT MAY HAVE OCCURRED DURING INSTALLATION.
- WHEN USING DECODERS, IT IS REQUIRED TO LOCATE THE DECODER AT THE VALVE IT SERVES TO REDUCE THE OUTPUT WIRE PATH EXPOSURE TO LIGHTNING. IT ALSO MAKES IT EASIER TO LOCATE FOR SERVICE.
- TWO WIRE PATH LINE SURGE PROTECTOR - (#TW-LA-1) SURGE PROTECTOR AND GROUNDING EQUIPMENT SHOULD BE INSTALLED EVERY 500 FEET ON THE TWO WIRE PATH.
- COMMUNICATION CABLE MUST BE CONNECTED BLACK TO BLACK AND RED TO RED AT ALL SPLICES WITH RAINMASTER #TW-SPLICE-14 WATERPROOF SPLICE KITS.
- REMOTE CONTROL VALVES MUST BE EQUIPPED WITH SOLENOIDS, COMPATIBLE WITH RAINMASTER TWO-WIRE CONTROL SYSTEM.
- ALL DECODER / CONTROL WIRING WORK IS TO BE IN COMPLIANCE WITH MANUFACTURERS (RAINMASTER) RECOMMENDATIONS.
- CONTRACTOR IS TO HAVE ALL FIELD PERSONNEL INSTALLING RAINMASTER DECODERS, COMMUNICATION CABLE AND REMOTE CONTROL VALVE WIRING TO BE TRAINED BY AN AUTHORIZED RAINMASTER REPRESENTATIVE, CHRIS STEELE, (559) 779-8676 PRIOR TO STARTING CONSTRUCTION.
- CONTRACTOR IS TO HAVE ALL RAINMASTER 2-WIRE PATH WIRING, COMMUNICATION CABLE AND REMOTE CONTROL VALVE WIRING AND 2-WIRE PATH GROUNDING INSPECTED PRIOR TO BACKFILL BY AN AUTHORIZED RAINMASTER REPRESENTATIVE, CHRIS STEELE, (559) 779-8676.

31 1 1/2" REMOTE CONTROL VALVE W / RAINMASTER 1 STATION DECODER ON 2-WIRE PATH NTS

33 2-WIRE PATH & STATION DECODER NOTES NTS

LANDSCAPE & IRRIGATION NOTES

- PRODUCT "OR APPROVED EQUAL" SPECIFICATION NOTE: ALL SPECIFIED MATERIALS, PRODUCTS AND MANUFACTURERS ARE RELEVANT TO DESCRIBE THE REQUIRED QUALITY AND FEATURES OF A PARTICULAR COMPONENT OF THE PROJECT, HOWEVER, THE SPECIFIC PRODUCT OR MANUFACTURER NOTED IS TO BE CONSTRUED TO BE FOLLOWED BY THE WORDS, "OR APPROVED EQUAL".
- GENERAL NOTE: THE CONTRACTOR IS TO SUPPLY ALL EQUIPMENT, MATERIALS AND LABOR TO PROVIDE A COMPLETE AND OPERATIONAL SYSTEM. ADDITIONAL EQUIPMENT AND MATERIALS IN ADDITION TO THE SYSTEM COMPONENTS LISTED IN THE LEGEND MAY BE REQUIRED TO PROVIDE A COMPLETE AND OPERATIONAL SYSTEM.
- IRRIGATION CONTROLLERS 120 VOLT ELECTRICAL WIRING AND DATA NOTE: THE CONTRACTOR IS RESPONSIBLE FOR ALL ELECTRICAL AND DATA IMPROVEMENTS REQUIRED TO SUPPLY 120 VOLT POWER AND CAT-6 DATA CABLE TO THE NEW IRRIGATION CONTROLLER LOCATION. SEE ELECTRICAL AND DATA PLANS FOR ADDITIONAL INFORMATION. CONTRACTOR IS TO PROVIDE ALL LABOR, MATERIALS AND EQUIPMENT REQUIRED FOR A COMPLETE INSTALLATION CONSTRUCTED TO CODE.
- SPRINKLER ADJUSTMENT NOTE: CONTRACTOR SHALL MAKE ANY ADJUSTMENTS OR CHANGES TO SPRINKLERS, NOZZLES, RADIUS AND ARCS AS REQUIRED TO PROVIDE 100% COVERAGE TO ALL LANDSCAPE AREAS AND PREVENT OVER SPRAY ONTO BUILDINGS OR HARDESCAPED SURFACES AT NO ADDITIONAL COST TO THE PROJECT.

10/25/23	ADDENDUM NO. 5
MARK	DATE
	DESCRIPTION
	9/2/23
	DSA BACK CHECK

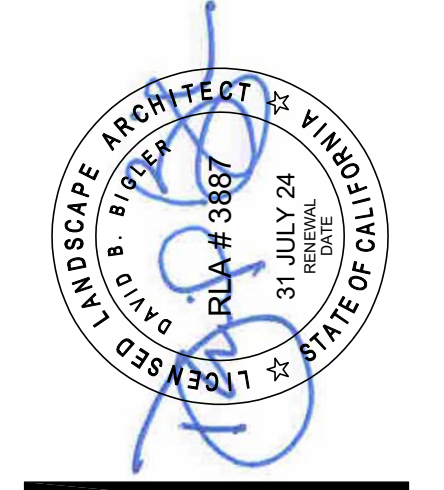

TETER, LLP
 FRESNO HEADQUARTERS
 31 JULY 24
 VESALIA 1 BAKERSFIELD 1 MODESTO 1 SAN LUIS CRISPO
 ARCHITECTS ENGINEERS CONNECTED

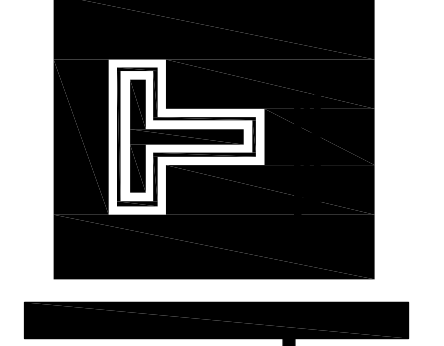

**ONLINE SCHOOL & SPECIAL EDUCATION
 ADMINISTRATION DISTRICT OFFICE EXPANSION
 CLOVIS UNIFIED SCHOOL DISTRICT
 CLOVIS, CA**
 DRAWING TITLE
LANDSCAPE AND IRRIGATION DETAILS

David Bigler Associates
 Landscape Architect #3887
 518 W. Shaw Avenue
 Fresno, California 93704
 E Mail: davidbigler@dbai.com
 Tel: (559) 276-9485
 Fax: (559) 276-9487

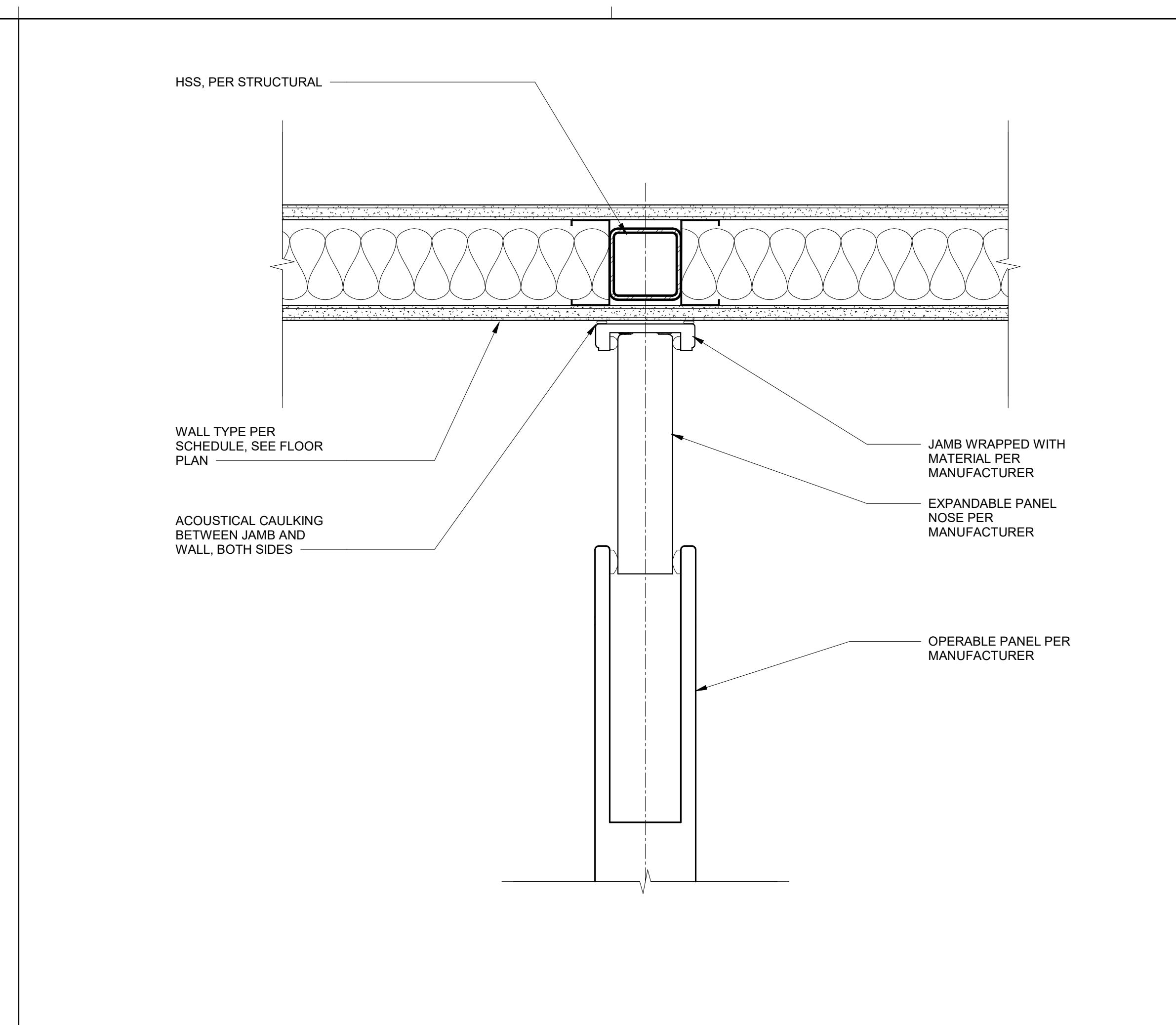

EXPANDABLE OPERABLE PANEL JAMB AT POCKET 3" = 1'-0" 12

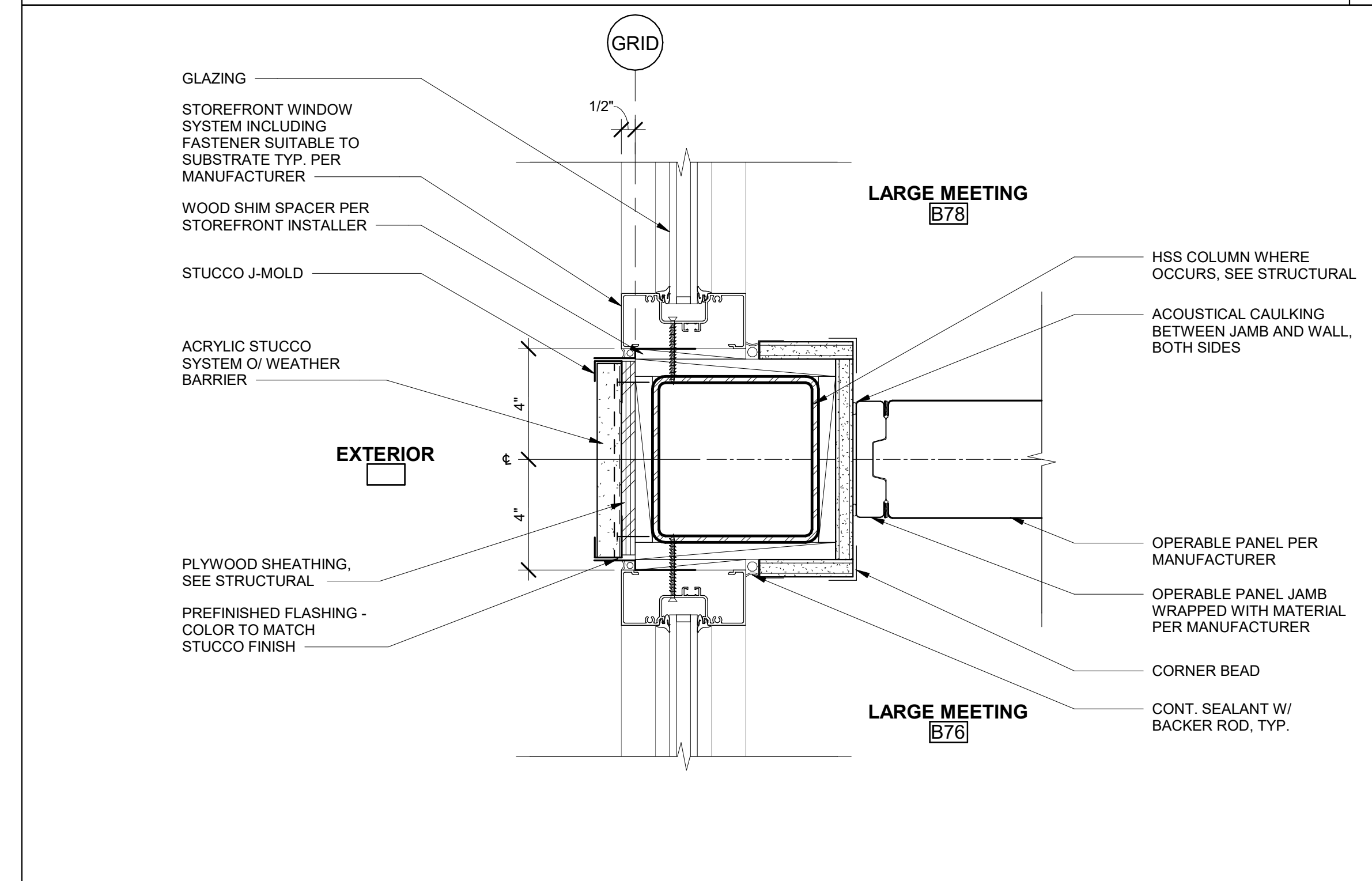

OPERABLE PANEL JAMB AT STOREFRONT 3" = 1'-0" 14

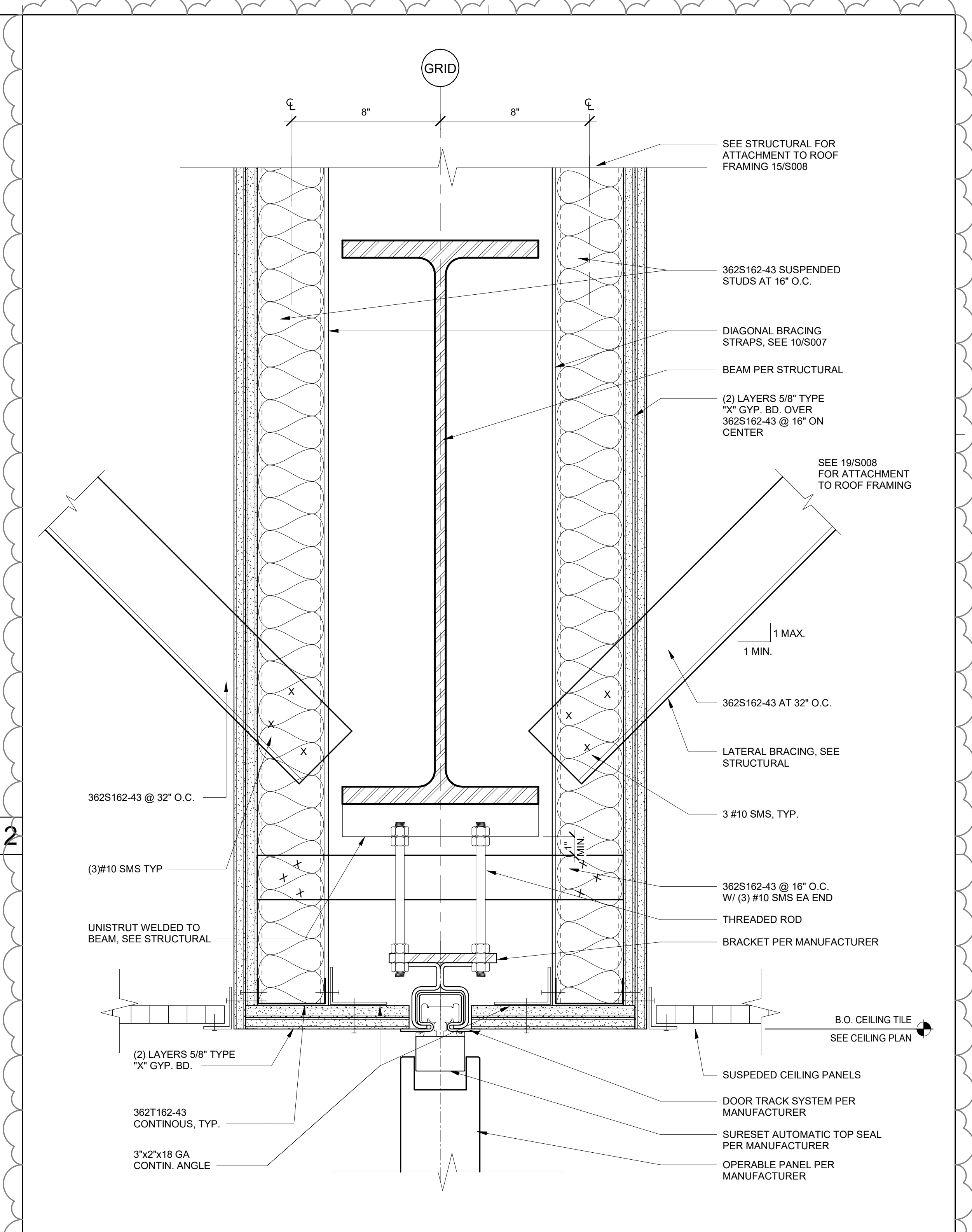

OPERABLE PANEL HEAD 3" = 1'-0" 3

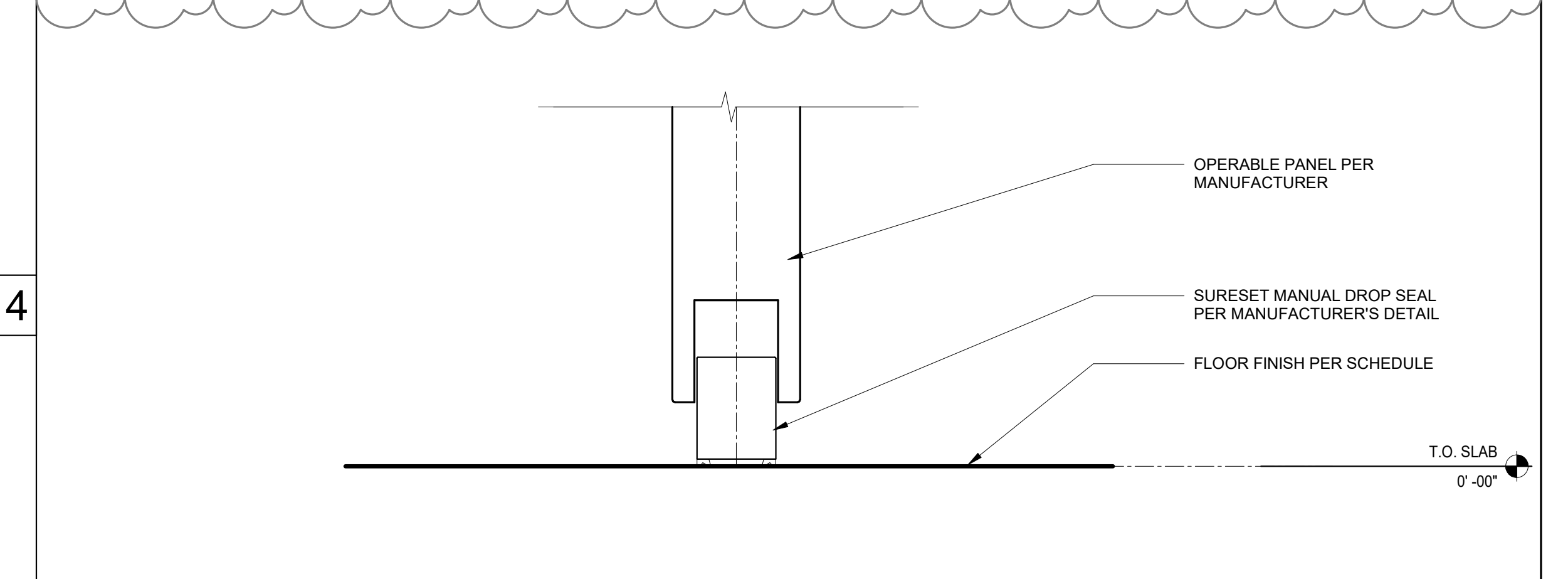

OPERABLE PANEL SILL 3" = 1'-0" 4

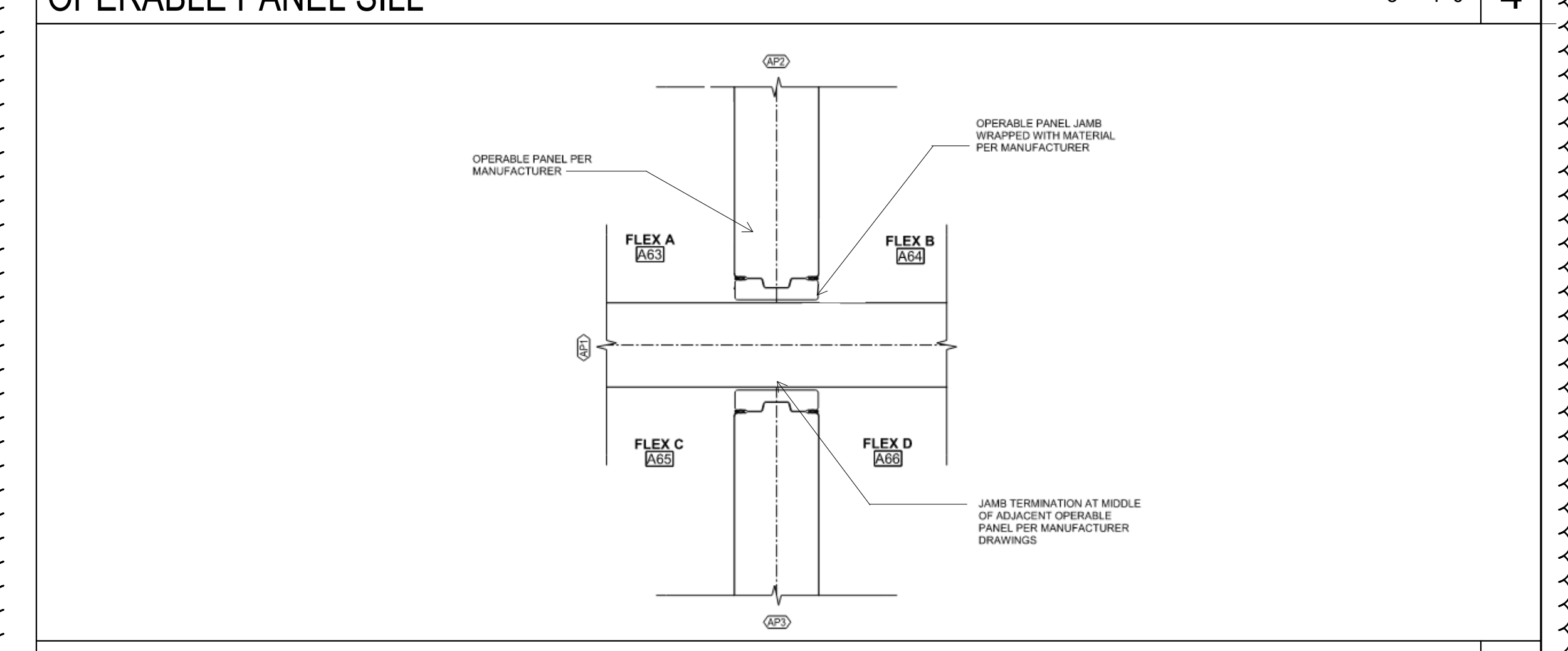

OPERABLE PANEL JAMB AT PANEL INTERSECTION 3" = 1'-0" 5

MARK	DATE	DESCRIPTION
1	7/17/23	DSA BACKCHECK



TETER, INC.
 ARCHITECTS ENGINEERS CONNECTED
 FRESNO HEADQUARTERS
 VISALIA BRANCH OFFICE

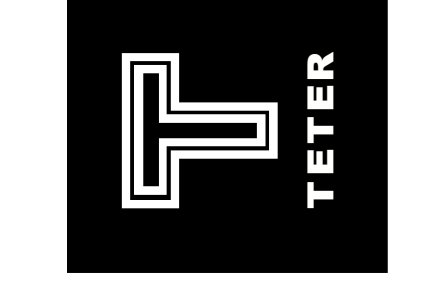

**ONLINE SCHOOL & SPECIAL EDUCATION
 ADMINISTRATION DISTRICT OFFICE EXPANSION
 CLOVIS UNIFIED SCHOOL DISTRICT**
 CLOVIS, CA
 DRAWING TITLE
 INTERIOR OPENING DETAILS

PROJECT NO.
 12242.00
 DRAWING
A831

MARK	DATE	DESCRIPTION	DSR BACKCHECK
	7/17/23		

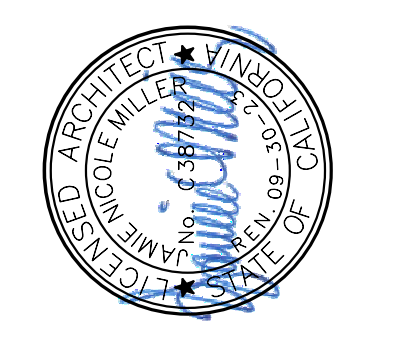

TETER, INC.
FRESNO HEADQUARTERS
1500 N. BARNESFIELD / FRESNO, CA 93701
ARCHITECTS ENGINEERS CONNECTED

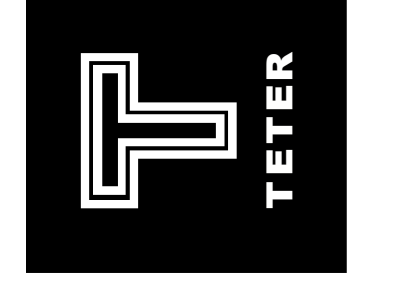

ONLINE SCHOOL & SPECIAL EDUCATION
ADMINISTRATION DISTRICT OFFICE EXPANSION
CLOVIS UNIFIED SCHOOL DISTRICT
CLOVIS, CA
DRAWING TITLE
FINISH FLOOR PLAN - BLDG A - ONLINE SCHOOL

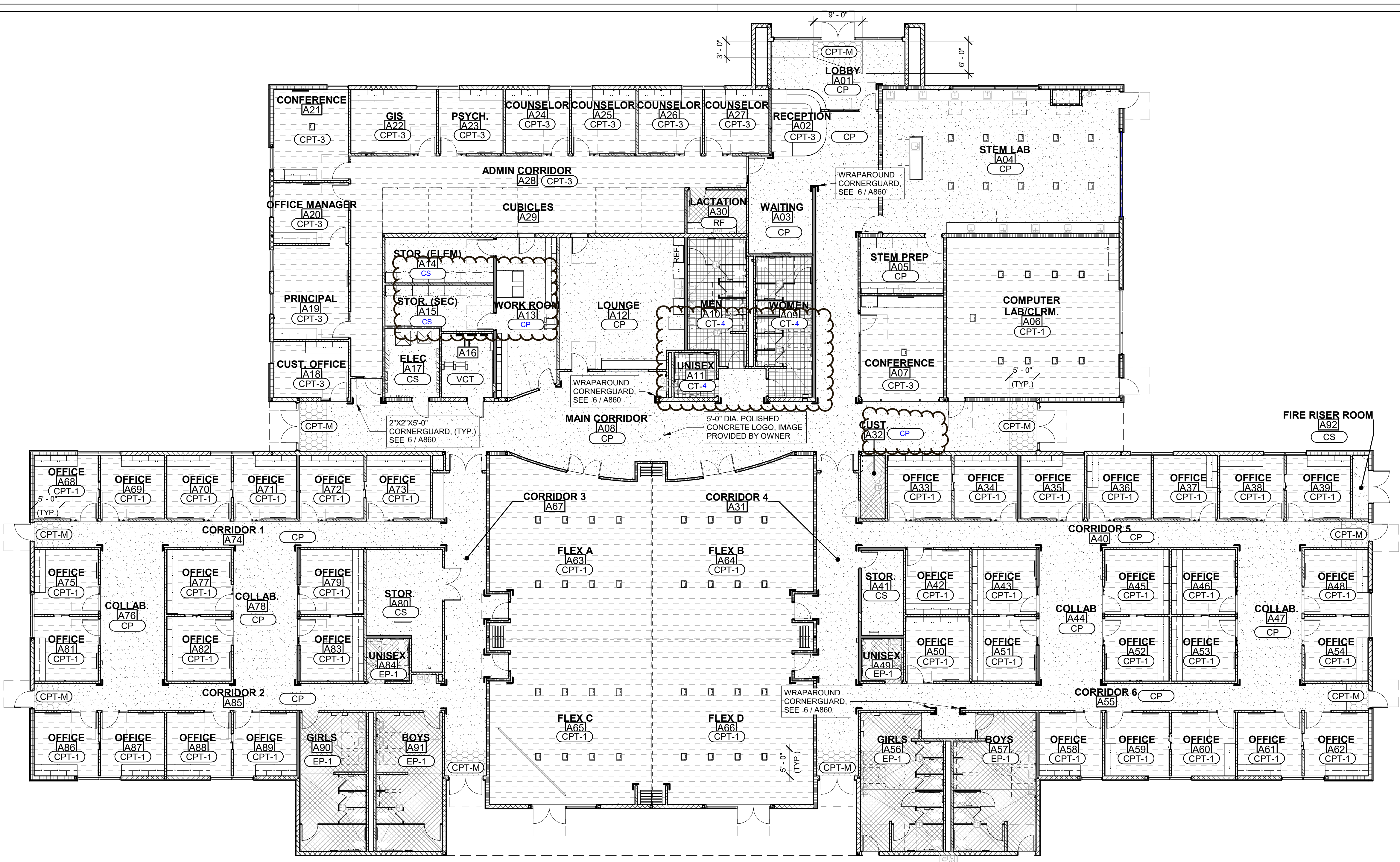

FLOOR FINISH PLAN - BLDG A - ONLINE SCHOOL

3/32" = 1'-0" 3

GENERAL NOTES

- SEE INTERIOR ELEVATIONS FOR WAINSCOT/MATERIAL HEIGHT.

REMARKS

- A. AT EXPOSED CEILING LOCATIONS, PAINT ALL EXPOSED STRUCTURE, DUCTS, PIPING, UNDERSIDE OF J. T.O. TACKABLE WALL PANEL AT 8'-0".
- B. INSULATION, PROVIDE 2" X 1" GYPSUM, METAL TRIM, GYPSUM, UNFINISHED INSULATION MEETS JOINT.
- C. 4" X 6" ALUM. FRAMED TACKBOARD PANELS OVER PAINTED GYPSUM BOARD.
- D. CERAMIC TILE COVE BASE.
- E. CUBICLES/FURNITURE BY OWNER.
- F. SEE EXTERIOR FINISH SCHEDULE.
- G. SEE ELECTRICAL SPEC FOR ADDITIONAL PLYWOOD INFORMATION.
- H. EP. EPOXY COVERED BASE.
- I. GB. AT FLEX ROOM ABOVE.

ROOM FINISH SCHEDULE - ONLINE SCHOOL

#	ROOM NAME	FLOOR	BASE	NORTH	EAST	SOUTH	WEST	CEILING	EXPOSED COUNTERTOPS & BACKSPLASH	EXPOSED CASEWORK	REMARKS
A01	LOBBY	CPT/CPT-M	RB-2	GB-1	GB-1GB-6	GB-1GB-4	GB-6	EXP-3	PL-2/SS-2	PL-1	A
A02	RECEPTION	CPT-3	RB-2	GB-1	GB-1	GB-4	GB-6	EXP-3	PL-2	PL-1	A
A03	WAITING	CP	RB-2	GB-1	GB-1	GB-4	GB-6	EXP-3	PL-2	PL-1	A
A04	STEM LAB	CP	RB-2	GB-1	GB-1	GB-4	GB-6	EXP-3	PL-2	PL-1	A
A05	STEM PREP	CP	RB-2	GB-1	GB-1	GB-4	GB-6	EXP-3	PL-2	PL-1	A
A06	COMPUTER LAB/CULRM.	CPT-1	RB-1	GB-1	GB-1	GB-4	GB-6	EXP-3	PL-2	PL-1	A
A07	CONFERENCE	CPT-3	RB-2	GB-1	GB-1	GB-4	GB-6	EXP-3	PL-2	PL-1	A
A08	MAIN CORRIDOR	CPT/CPT-M	RB-2	GB-1GB-5/GB-4	GB-1GB-6	GB-1GB-4	GB-6	EXP-3	PL-2	PL-1	A
A09	WOMEN	CT-4	CT-4	CT-5	CT-5	CT-5	CT-5	GB-3			C
A10	MEN	CT-4	CT-4	CT-5	CT-5	CT-5	CT-5	GB-3			C
A11	UNISEX	CP	RB-2	CT-5	CT-5	CT-5	CT-5	GB-3			C
A12	LOUNGE	CP	RB-2	GB-3	GB-3	GB-3	GB-3	EXP-3	PL-2	PL-1	A
A13	WORK ROOM	CP	RB-2	GB-1	GB-1	GB-1	GB-1	EXP-3	PL-2	PL-1	A
A14	STOR. (ELEM)	CS	RB-2	GB-1	GB-1	GB-1	GB-1	EXP-3	PL-2	PL-1	A
A15	STOR. (SEC)	CS	RB-2	GB-1	GB-1	GB-1	GB-1	EXP-3	PL-2	PL-1	A
A16	ELEC	VCT	RB-2	GB-1PW	GB-1PW	GB-1PW	GB-1PW	EXP-1			F
A17	ELEC	CS	RB-2	GB-1	GB-1	GB-1	GB-1	EXP-1			F
A18	CUST. OFFICE	CPT-3	RB-2	GB-6	GB-1	GB-1GB-2	GB-1	EXP-3	PL-2	PL-1	A
A19	PRINCIPAL	CPT-3	RB-2	GB-1GB-2	GB-1	GB-1	GB-1	EXP-3	PL-2	PL-1	A
A20	OFFICE MANAGER	CPT-3	RB-2	GB-1GB-2	GB-6	GB-1	GB-1	EXP-3	PL-2	PL-1	A
A21	CONFERENCE	CPT-3	RB-2	GB-1	GB-1	GB-1	GB-1	EXP-3	PL-2	PL-1	A
A22	GIS	CPT-3	RB-2	GB-6	GB-1	GB-1	GB-1GB-2	EXP-3	PL-2	PL-1	A
A23	PSYCH.	CPT-3	RB-2	GB-6	GB-1	GB-1	GB-1GB-2	EXP-3	PL-2	PL-1	A
A24	COUNSELOR	CPT-3	RB-2	GB-6	GB-1	GB-1	GB-1GB-2	EXP-3	PL-2	PL-1	A
A25	COUNSELOR	CPT-3	RB-2	GB-6	GB-1	GB-1	GB-1GB-2	EXP-3	PL-2	PL-1	A
A26	COUNSELOR	CPT-3	RB-2	GB-6	GB-1	GB-1	GB-1GB-2	EXP-3	PL-2	PL-1	A
A27	COUNSELOR	CPT-3	RB-2	GB-6	GB-1	GB-1	GB-1GB-2	EXP-3	PL-2	PL-1	A
A28	ADMIN CORRIDOR	CPT-3	RB-2	GB-1	GB-1	GB-1	GB-1	EXP-3	PL-2	PL-1	A
A29	CUBICLES	CPT-3	RB-2	GB-1	GB-1	GB-1	GB-1	EXP-3	PL-2	PL-1	A
A30	LACTATION	RF	RB-2	GB-1	GB-1	GB-1	GB-1	EXP-3	PL-2	PL-1	A
A31	CORRIDOR 4	CPT/CPT-M	RB-2	GB-1GB-6	GB-1	GB-1GB-6	GB-1	EXP-3	PL-2	PL-1	A
A32	CUST.	CS	RB-2	FRP-1	FRP-1	FRP-1	FRP-1	EXP-3	PL-2	PL-1	A
A33	OFFICE	CPT-1	RB-1	GB-1	GB-1	GB-1	GB-1	EXP-3	PL-2	PL-1	A
A34	OFFICE	CPT-1	RB-1	GB-6	GB-1	GB-1	GB-1GB-2	EXP-3	PL-2	PL-1	A
A35	OFFICE	CPT-1	RB-1	GB-6	GB-1	GB-1	GB-1GB-2	EXP-3	PL-2	PL-1	A
A36	OFFICE	CPT-1	RB-1	GB-6	GB-1	GB-1	GB-1GB-2	EXP-3	PL-2	PL-1	A
A37	OFFICE	CPT-1	RB-1	GB-1	GB-6	GB-1	GB-1GB-2	EXP-3	PL-2	PL-1	A
A38	OFFICE	CPT-1	RB-1	GB-6	GB-1	GB-1	GB-1GB-2	EXP-3	PL-2	PL-1	A
A39	OFFICE	CPT-1	RB-1	GB-6	GB-1GB-2	GB-1	GB-1	EXP-3	PL-2	PL-1	A
A40	CORRIDOR 5	CPT/CPT-M	RB-2	GB-1	GB-1	GB-1	GB-1	EXP-3	PL-2	PL-1	A
A41	STOR.	CS	RB-2	GB-1	GB-1	GB-1	GB-1	EXP-3	PL-2	PL-1	A
A42	OFFICE	CPT-1	RB-1	GB-1	GB-1GB-2	GB-6	GB-1	EXP-3	PL-2	PL-1	A
A43	OFFICE	CPT-1	RB-1	GB-1GB-2	GB-1	GB-1	GB-1	EXP-3	PL-2	PL-1	A
A44	COLLAB.	CP	RB-2	GB-1GB-7	GB-1	GB-1GB-7	GB-1	EXP-3	PL-2	PL-1	A
A45	OFFICE	CPT-1	RB-1	GB-1GB-2	GB-1	GB-1	GB-1	EXP-3	PL-2	PL-1	A

ROOM FINISH SCHEDULE - ONLINE SCHOOL

#	ROOM NAME	FLOOR	BASE	NORTH	EAST	SOUTH	WEST	CEILING	EXPOSED COUNTERTOPS & BACKSPLASH	EXPOSED CASEWORK	REMARKS
A46	OFFICE	CPT-1	RB-1	GB-1GB-2	GB-1	GB-1	GB-6	EXP-3	PL-2	PL-1	A
A47	COLLAB.	CP	RB-2	GB-1GB-7	GB-1	GB-1	GB-1GB-7	EXP-3	PL-2	PL-1	A
A48	OFFICE	CPT-1	RB-1	GB-1GB-2	GB-6	GB-1	GB-1GB-7	EXP-3	PL-2	PL-1	A
A49	UNISEX	EP-1	EP-1	CT-1/CT-2/CT-3	CT-1/CT-2/CT-3	CT-1/CT-2/CT-3	CT-1/CT-2/CT-3	GB-3			G
A50	OFFICE	CPT-1	RB-1	GB-6	GB-1GB-2	GB-1	GB-1	EXP-3	PL-2	PL-1	A
A51	OFFICE	CPT-1	RB-1	GB-1	GB-1	GB-1GB-2	GB-6	EXP-3	PL-2	PL-1	A
A52	OFFICE	CPT-1	RB-1	GB-1	GB-6	GB-1GB-2	GB-1	EXP-3	PL-2	PL-1	A
A53	OFFICE	CPT-1	RB-1	GB-1	GB-6	GB-1GB-2	GB-1	EXP-3	PL-2	PL-1	A
A54	OFFICE	CPT-1	RB-1	GB-1	GB-1GB-2	GB-1	GB-1	EXP-3	PL-2	PL-1	A
A55	CORRIDOR 6	CPT/CPT-M	RB-2	GB-1GB-4	GB-1GB-7	GB-1GB-7	GB-1GB-7	EXP-3	PL-2	PL-1	A
A56	GIRLS	EP-1	EP-1	CT-1/CT-2/CT-3	CT-1/CT-2/CT-3	CT-1/CT-2/CT-3	CT-1/CT-2/CT-3	GB-3			G
A57	BOYS	EP-1	EP-1	CT-1/CT-2/CT-3	CT-1/CT-2/CT-3	CT-1/CT-2/CT-3	CT-1/CT-2/CT-3	GB-3			G
A58	OFFICE	CPT-1	RB-1	GB-1	GB-6	GB-1GB-2	GB-1	EXP-3	PL-2	PL-1	A
A59	OFFICE	CPT-1	RB-1	GB-1	GB-6	GB-1GB-2	GB-1	EXP-3	PL-2	PL-1	A
A60	OFFICE	CPT-1	RB-1	GB-1	GB-6	GB-1GB-2	GB-1	EXP-3	PL-2	PL-1	A
A61	OFFICE	CPT-1	RB-1	GB-1	GB-6	GB-1GB-2	GB-1	EXP-3	PL-2	PL-1	A
A62	OFFICE	CPT-1	RB-1	GB-1	GB-1GB-2	GB-6	GB-1	EXP-3	PL-2	PL-1	A
A63	FLEX A	EP-1	EP-1	GB-1	GB-1	GB-1	GB-1	EXP-3	PL-2	PL-1	A
A64	FLEX B	CPT-1	RB-1	GB-1	GB-6	GB-1	GB-6	EXP-3	PL-2	PL-1	A
A65	FLEX C	CPT-1	RB-1	GB-1	GB-6	GB-1	GB-6	EXP-3	PL-2	PL-1	A
A66	FLEX D	CPT-1	RB-1	GB-1	GB-6	GB-1	GB-6	EXP-3	PL-2	PL-1	A
A67	CORRIDOR 3	CPT/CPT-M	RB-2	GB-1GB-6	GB-1GB-6	GB-1GB-6	GB-1	EXP-3	PL-2	PL-1	A
A68	OFFICE	CPT-1	RB-1	GB-6	GB-1	GB-1	GB-1GB-2	EXP-3	PL-2	PL-1	A
A69	OFFICE	CPT-1	RB-1	GB-6	GB-1GB-2	GB-1	GB-1	EXP-3	PL-2	PL-1	A
A70	OFFICE	CPT-1	RB-1	GB-6	GB-1	GB-1	GB-1GB-2	EXP-3	PL-2	PL-1	A
A71	OFFICE	CPT-1	RB-1	GB-6	GB-1GB-2	GB-1	GB-1	EXP-3	PL-2	PL-1	A
A72	OFFICE	CPT-1	RB-1	GB-6	GB-1GB-2	GB-1	GB-1	EXP-3	PL-2	PL-1	A
A73	OFFICE	CPT-1	RB-1	GB-6	GB-1GB-2	GB-1	GB-1	EXP-3	PL-2	PL-1	A
A74	CORRIDOR 1	CPT/CPT-M	RB-2	GB-1	GB-1	GB-1	GB-1GB-4	EXP-3	PL-2	PL-1	A
A75	COLLAB.	CPT-1	RB-1	GB-1GB-2	GB-1	GB-1	GB-6	EXP-3	PL-2	PL-1	A
A76	COLLAB.	CP	RB-2	GB-1	GB-1GB-4	GB-1	GB-1GB-7	EXP-3	PL-2	PL-1	A
A77	OFFICE	CPT-1	RB-1	GB-1GB-2	GB-1	GB-1	GB-6	EXP-3	PL-2	PL-1	A
A78	COLLAB.	CP	RB-2	GB-1GB-7	GB-1	GB-1	GB-1GB-7	EXP-3	PL-2	PL-1	A
A79	OFFICE	CPT-1	RB-1	GB-1GB-2	GB-6	GB-1	GB-1	EXP-3	PL-2	PL-1	A
A80	STOR.	CS	RB-2	GB-1	GB-1	GB-1	GB-1	EXP-3	PL-2	PL-1	A
A81	OFFICE	CPT-1	RB-1	GB-1GB-2	GB-1	GB-6	GB-6	EXP-3	PL-2	PL-1	A
A82	OFFICE	CPT-1	RB-1	GB-1GB-2	GB-1	GB-6	GB-6	EXP-3	PL-2	PL-1	A
A83	OFFICE	CPT-1	RB-1	GB-1GB-2	GB-6	GB-1	GB-6	EXP-3	PL-2	PL-1	A
A84	UNISEX	EP-1	EP-1	CT-1/CT-2/CT-6	CT-1/CT-2/CT-6	CT-1/CT-2/CT-6	CT-1/CT-2/CT-6	GB-3			G
A85	CORRIDOR 2	CPT	RB-2	GB-1GB-4	GB-1	GB-1	GB-1	EXP-3	PL-2	PL-1	A
A86	OFFICE	CPT-1	RB-1	GB-1	GB-6	GB-1GB-2	GB-1	EXP-3	PL-2	PL-1	A
A87	OFFICE	CPT-1	RB-1	GB-1	GB-1GB-2	GB-6	GB-6	EXP-3	PL-2	PL-1	A
A88	OFFICE	CPT-1	RB-1	GB-1	GB-6	GB-1GB-2	GB-1	EXP-3	PL-2	PL-1	A
A89	OFFICE	CPT-1	RB-1	GB-1	GB-1GB-2	GB-6	GB-1	EXP-3	PL-2	PL-1	A
A90	GIRLS	EP-1	EP-1	CT-1/CT-2/CT-6	CT-1/CT-2/CT-6	CT-1/CT-2/CT-6	CT-1/CT-2/CT-6	GB-3			G
A91	BOYS	EP-1	EP-1	CT-1/CT-2/CT-6	CT-1/CT-2/CT-6	CT-1/CT-2/CT-6	CT-1/CT-2/CT-6	GB-3			G
A92	FIRE RISER ROOM	CS	RB-2	GB-1	GB-1	GB-1	GB-1	EXP-3	PL-2	PL-1	A

ABBREVIATIONS

ACP	SUSPENDED ACOUSTICAL CEILING PANEL	CT-1	CERAMIC WALL TILE (FIELD, WHITE)	FRP-1	FIBERGLASS REINFORCED PANEL	RB-1
-----	------------------------------------	------	----------------------------------	-------	-----------------------------	------

\\server1\Users\Elizabeth.Conti_TETRI\Documents\12242-A-DO_SITE_ealz.contreras.rvt

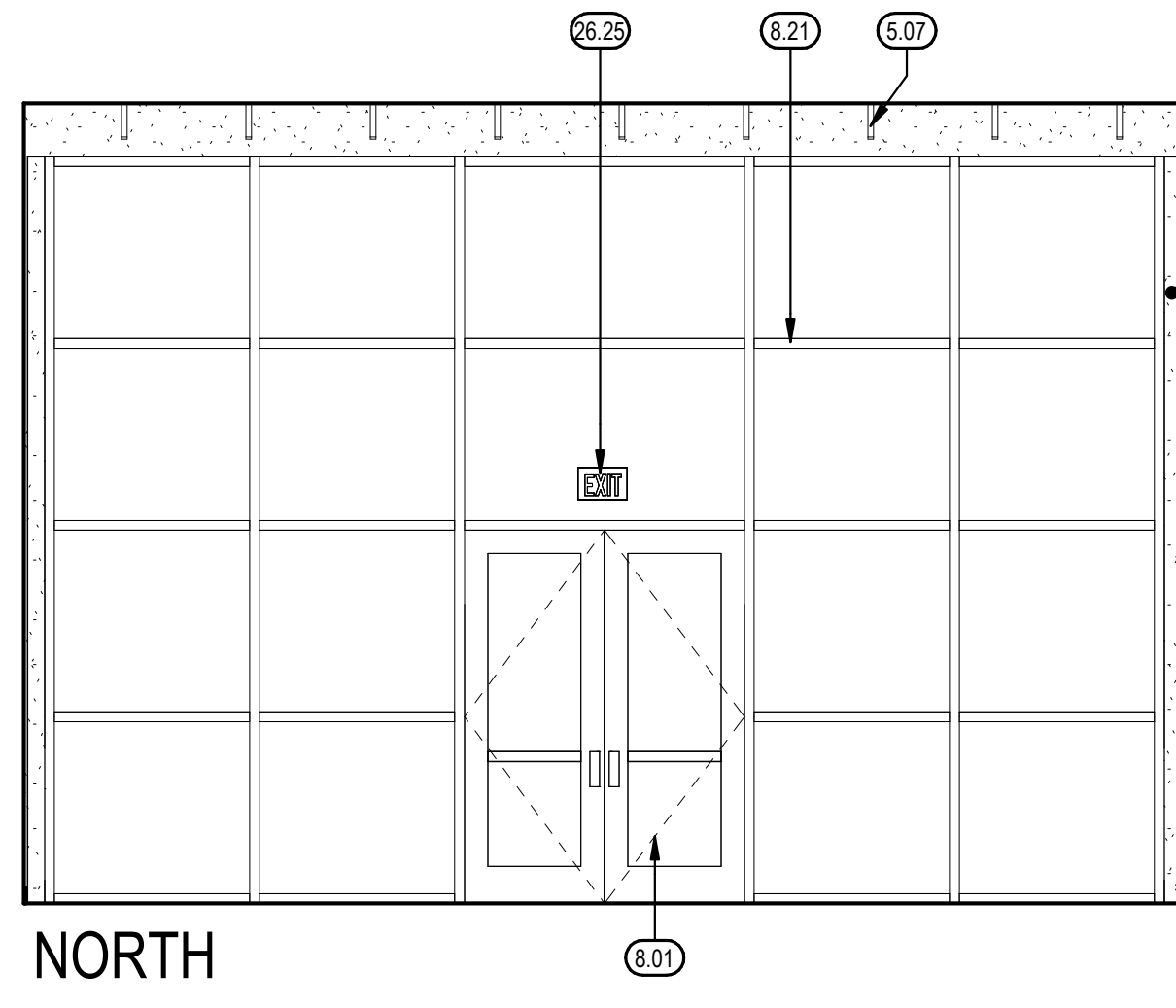

NORTH

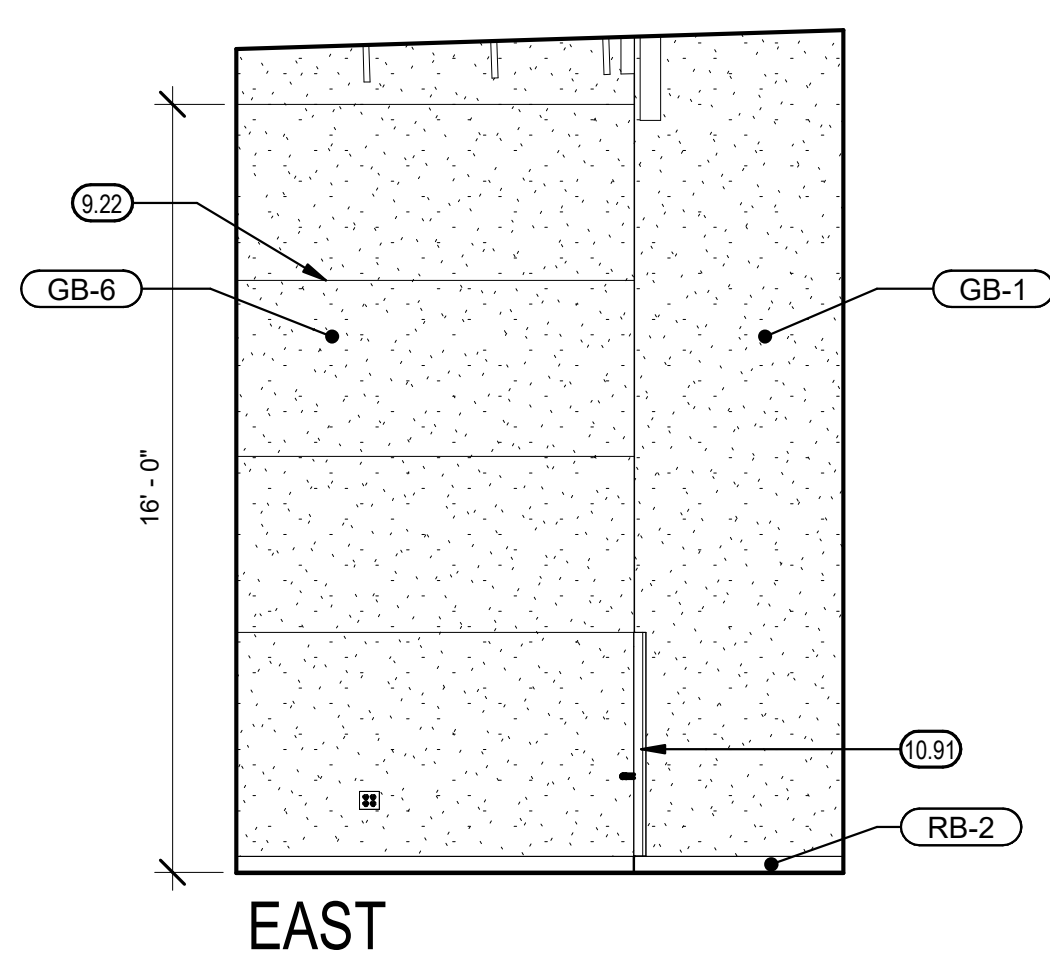

EAST

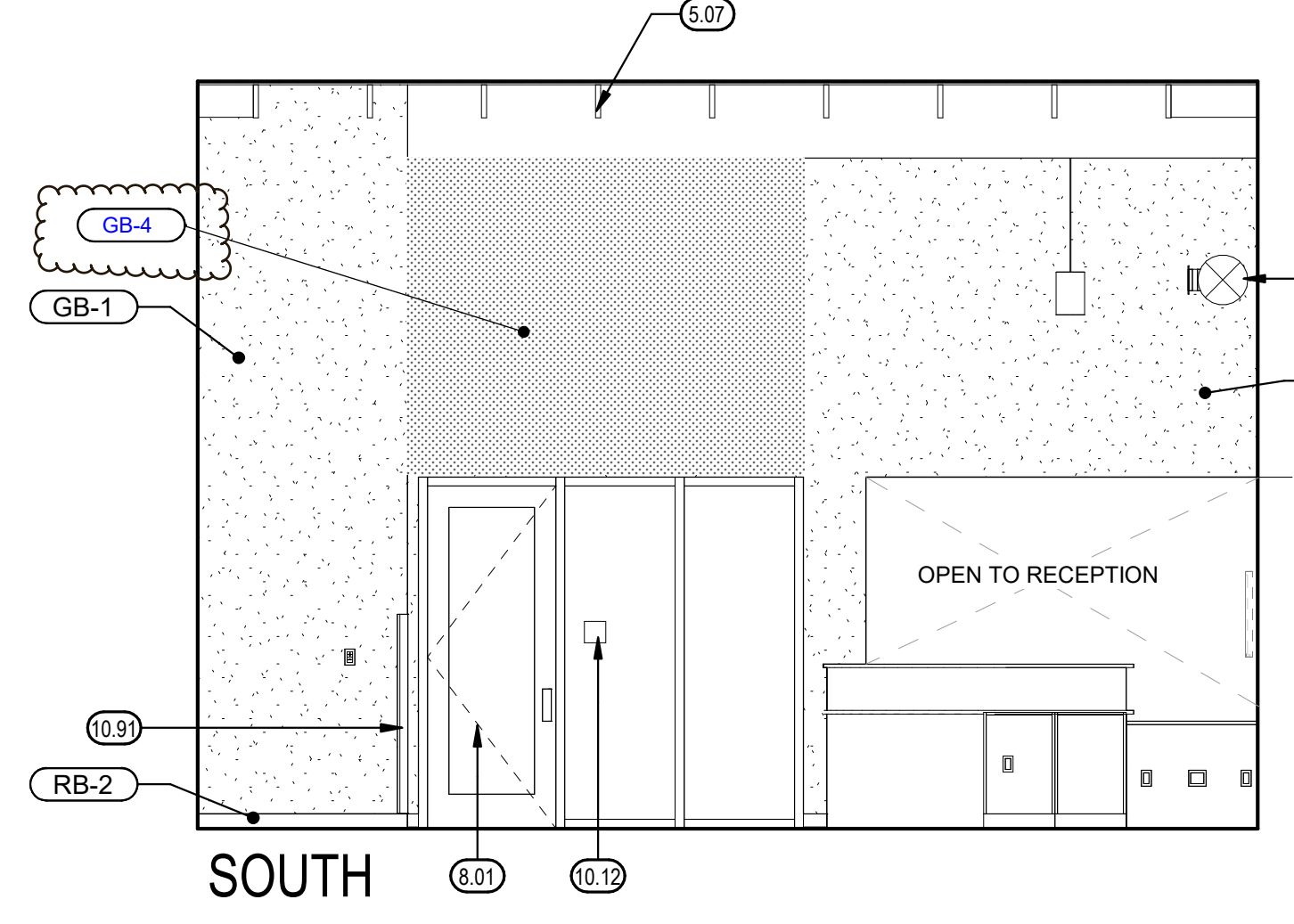

SOUTH

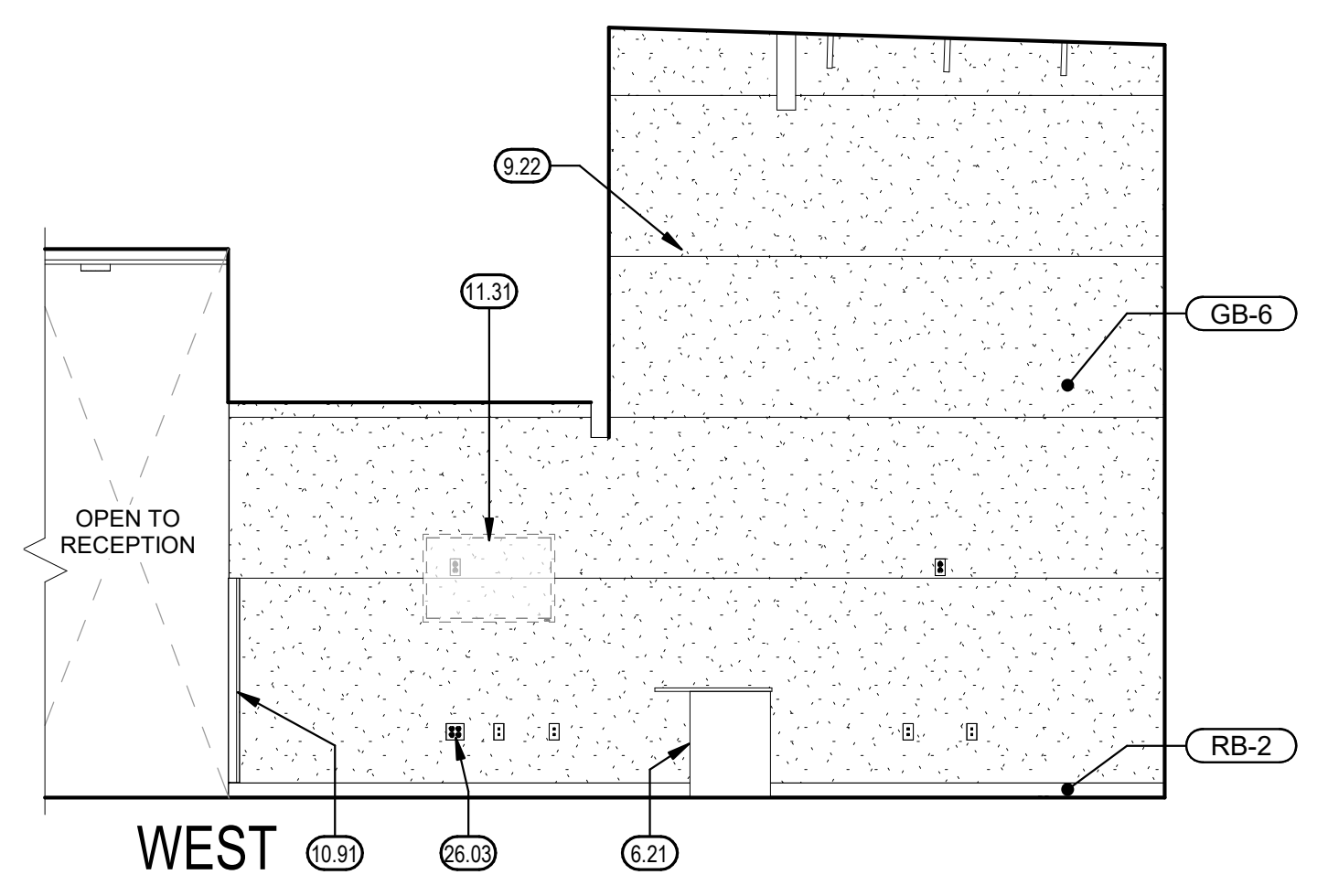

WEST

LOBBY - A01

1/4" = 1'-0" 6

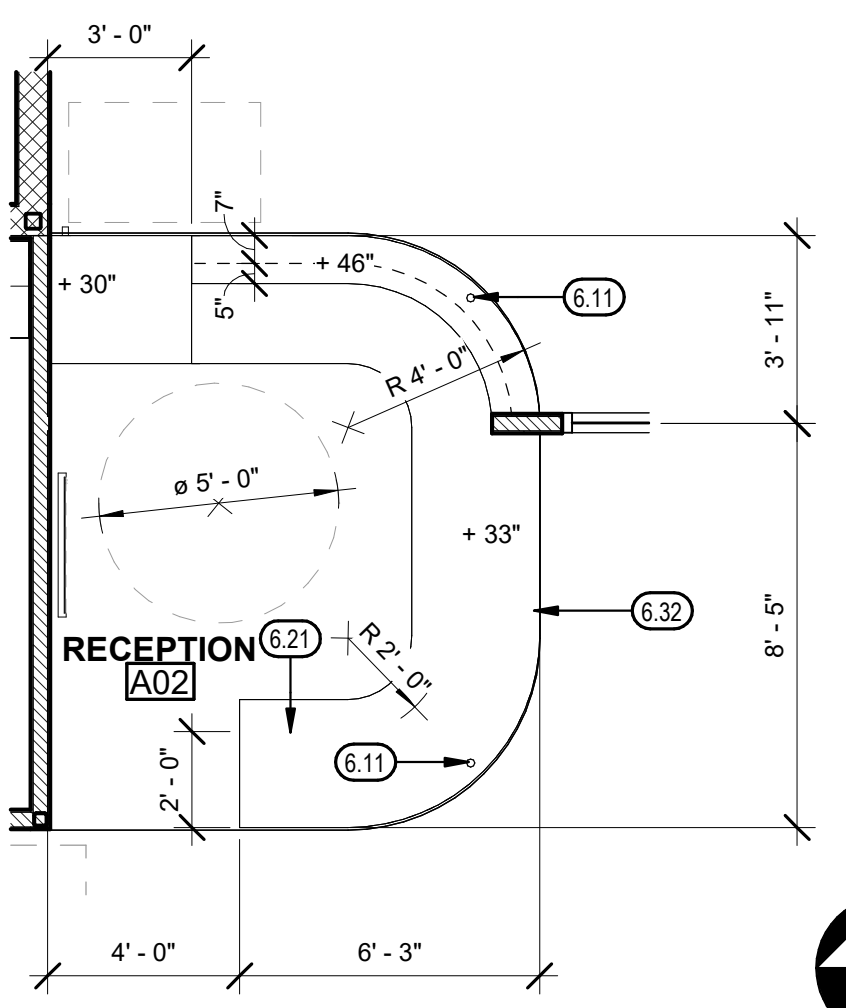

RECEPTION - A02 PLAN

1/4" = 1'-0" 28

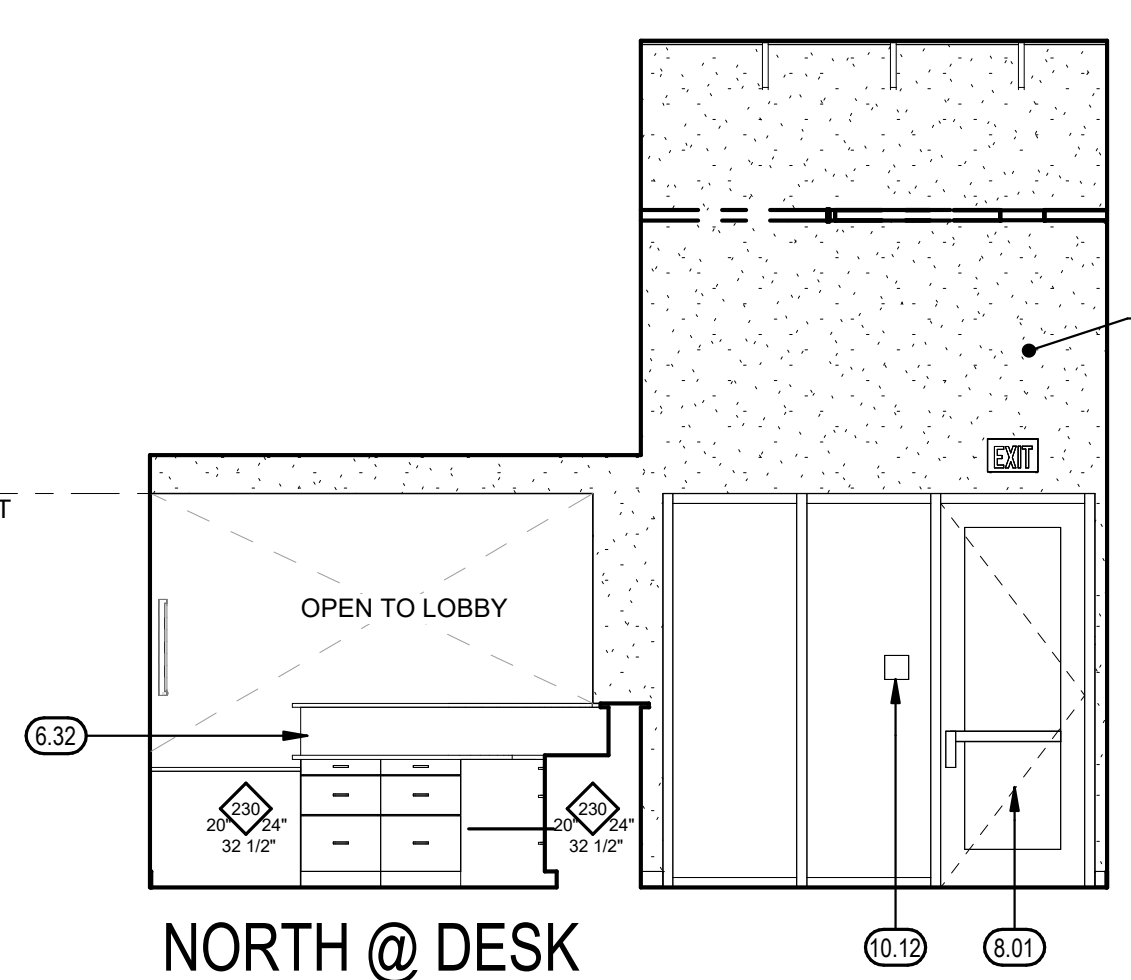

NORTH @ DESK

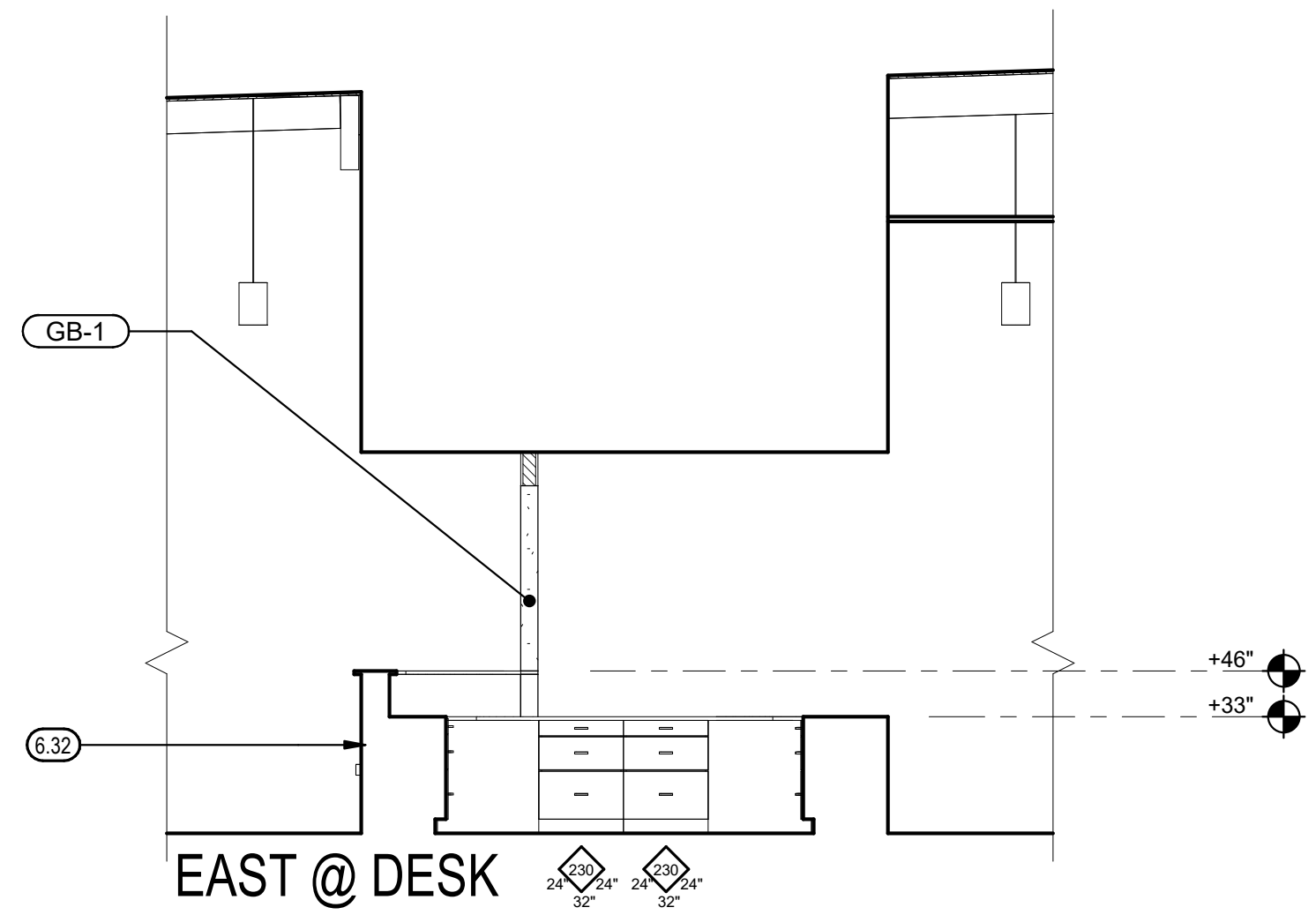

EAST @ DESK

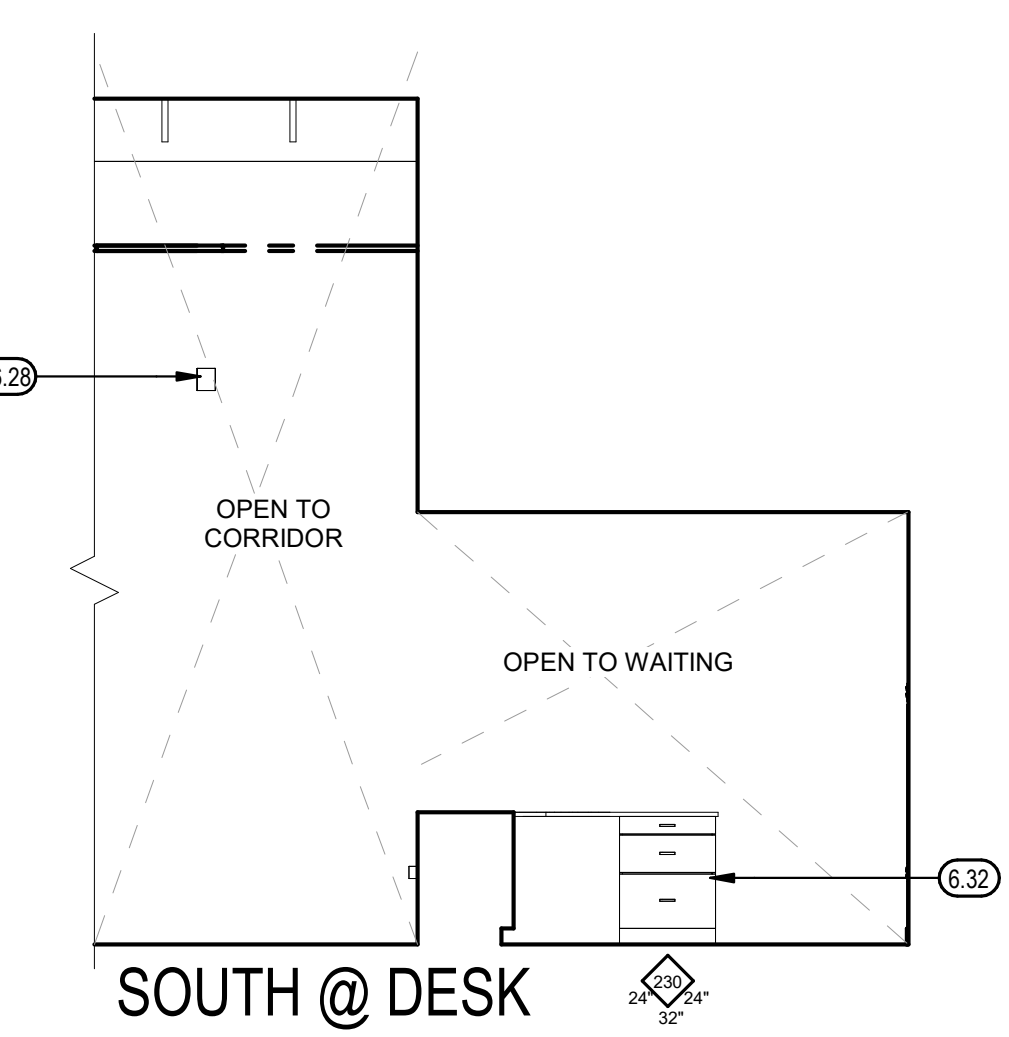

SOUTH @ DESK

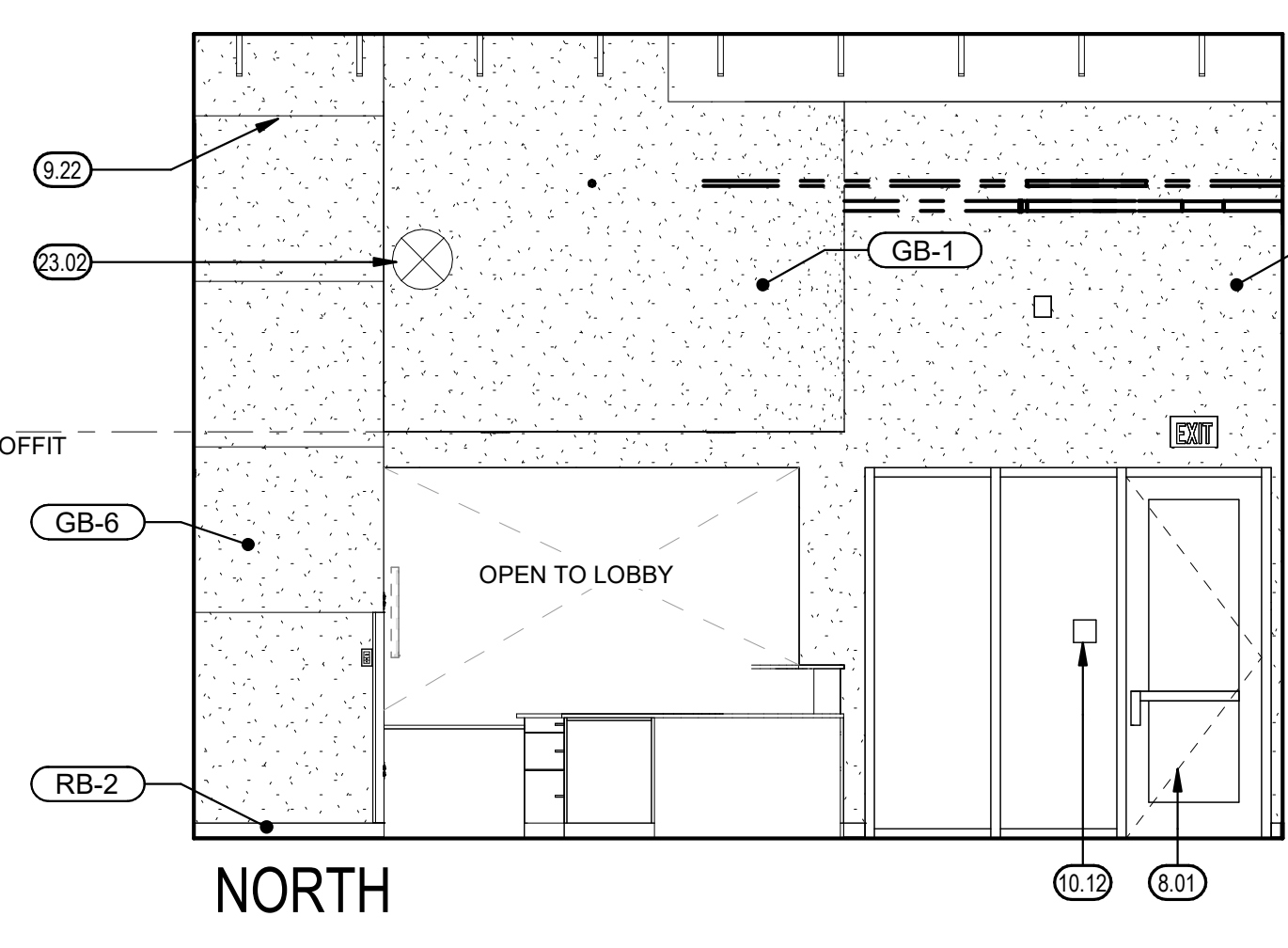

NORTH

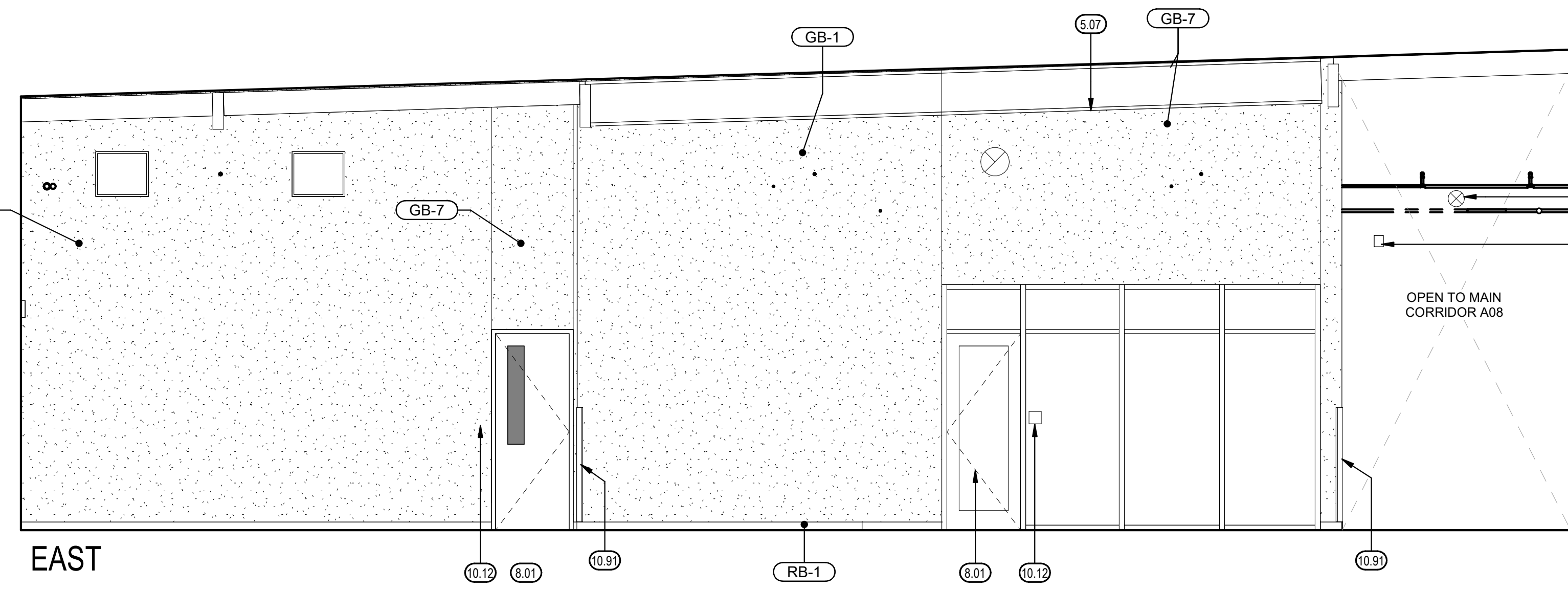

EAST

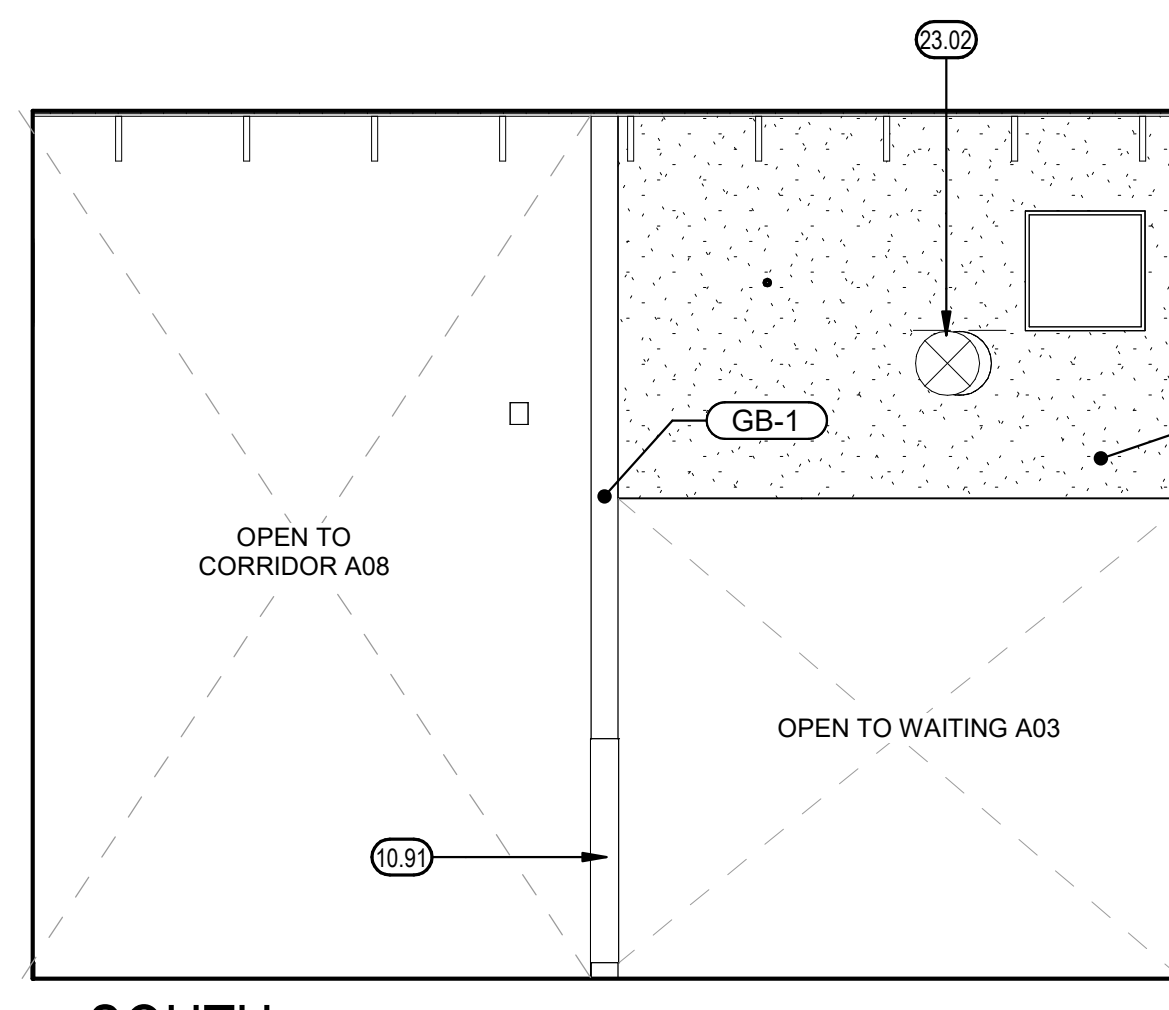

SOUTH

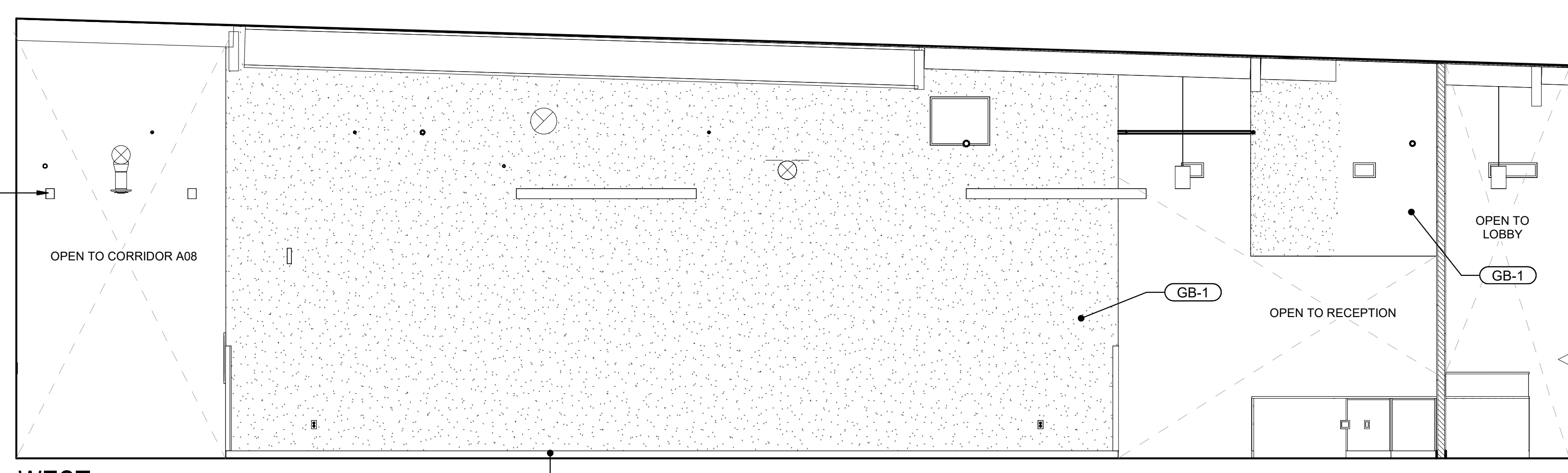

WEST

RECEPTION - A02

1/4" = 1'-0" 10

KEYNOTES

- 5.07 EXPOSED STRUCTURAL FRAMING
- 6.11 GROMMET AT DESK HEIGHT
- 6.21 PLASTIC LAMINATE BASE CABINET
- 6.32 PLASTIC LAMINATE RECEPTION COUNTER. SEE DETAIL 16 / A861, 21 / A861 & 26 / A861
- 8.01 DOOR AND FRAME AS SCHEDULED
- 8.21 ALUMINUM STOREFRONT
- 9.22 3/8" EXTRUDED ALUMINUM REVEAL FACTORY PRIMED, PAINT
- 10.12 ROOM IDENTIFICATION SIGNAGE, TYP. SEE DETAIL 3 / A801
- 10.91 CORNER GUARD, TYP. SEE DETAIL 6 / A860
- 11.31 PROVIDE BACKING FOR OFOI MONITOR, SEE DETAILS 1/A860, 3/A860, 8/A860, & 12/A860
- 23.02 DUCT, SEE MECHANICAL
- 26.03 WALL OUTLET, SEE ELECTRICAL, TYP.
- 26.25 EXIT SIGN, SEE ELECTRICAL
- 26.28 SUSPENDED LIGHT FIXTURE

IDENTIFICATION STAMP
DIV. OF THE STATE ARCHITECT
APP: 02-121813 INC.
REVIEWED FOR
DATE: 09/28/2023

For the separate use of these drawings, the user assumes all responsibility for any errors or omissions. The user agrees to indemnify and hold the architect harmless for any claims or damages arising out of the use of these drawings without the architect's written authorization.

MARK	DATE	DESCRIPTION
	7/17/23	DSA BACKCHECK

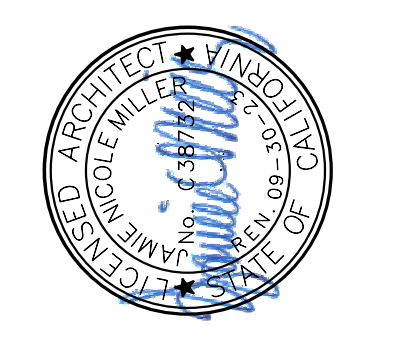

TETER, INC.
PRESNO HEADQUARTERS
VISALIA | BAKERSFIELD | MADERA | SAN LUIS OBISPO
ARCHITECTS ENGINEERS CONNECTED

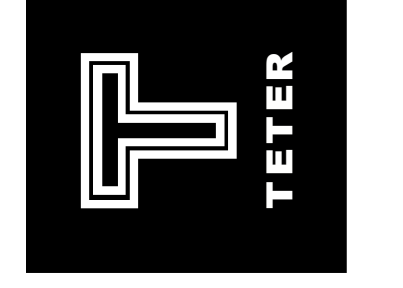

GENERAL NOTES

- A. PROVIDE BLOCKING FOR ALL WALL MOUNTED ACCESSORIES AND EQUIPMENT, TYP. SEE 1 / A860
- B. FOR ACCESSIBLE FIXTURE AND ACCESSORY MOUNTING HEIGHTS AND CLEARANCES, SEE 12 / A800, 3 / A800, AND 13 / A800
- C. FOR TYPICAL CASEWORK ANCHORAGE SEE 2 / A861
- D. FOR GRAB BAR ANCHORAGE SEE 9 / A800 AND 10 / A800
- E. FOR MIRROR ANCHORAGE SEE 19 / A800 AND 20 / A800
- F. SEE INTERIOR FINISH SCHEDULE A900 AND A940 FOR ADDITIONAL INFORMATION.

KEY PLAN

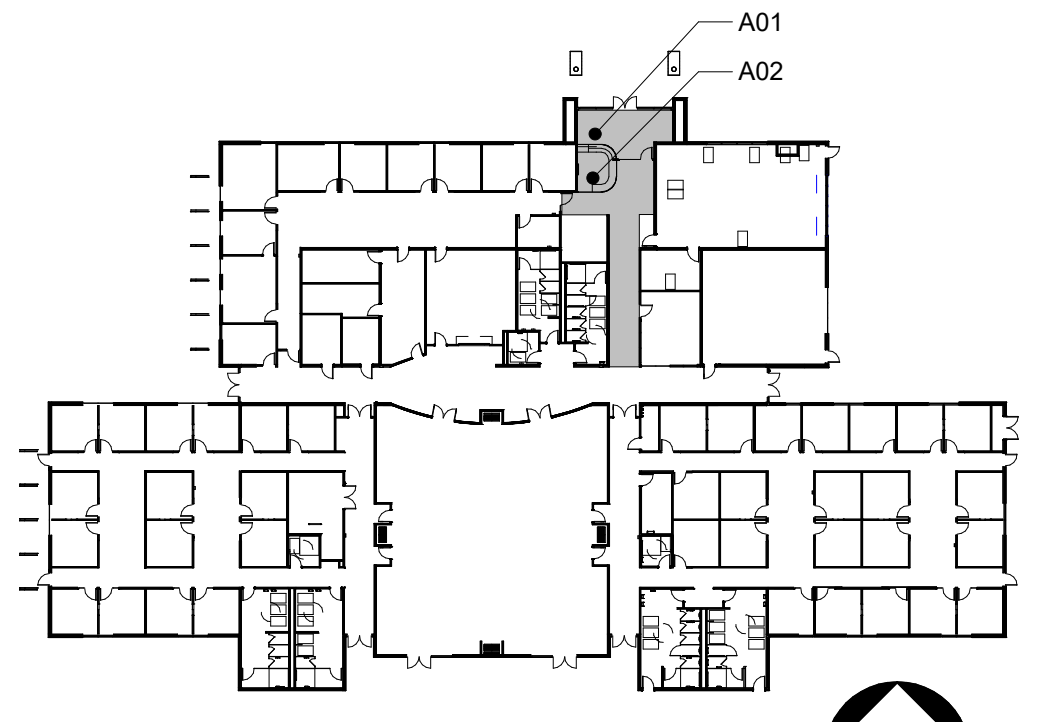

ONLINE SCHOOL & SPECIAL EDUCATION
ADMINISTRATION DISTRICT OFFICE EXPANSION
CLOVIS UNIFIED SCHOOL DISTRICT
CLOVIS, CA
DRAWING TITLE
INTERIOR ELEVATIONS - BLDG A - ONLINE SCHOOL

PROJECT NO.
12242.00
DRAWING
A910

PLOT DATE: 9/13/2023 2:01:04 PM

\\net-files\1\Users\Elizabeth.Conti_TETRI\Documents\12242-A-DOO_SITE_ealz.conterias.rvt

PLOT DATE: 9/13/2023 2:01:28 PM

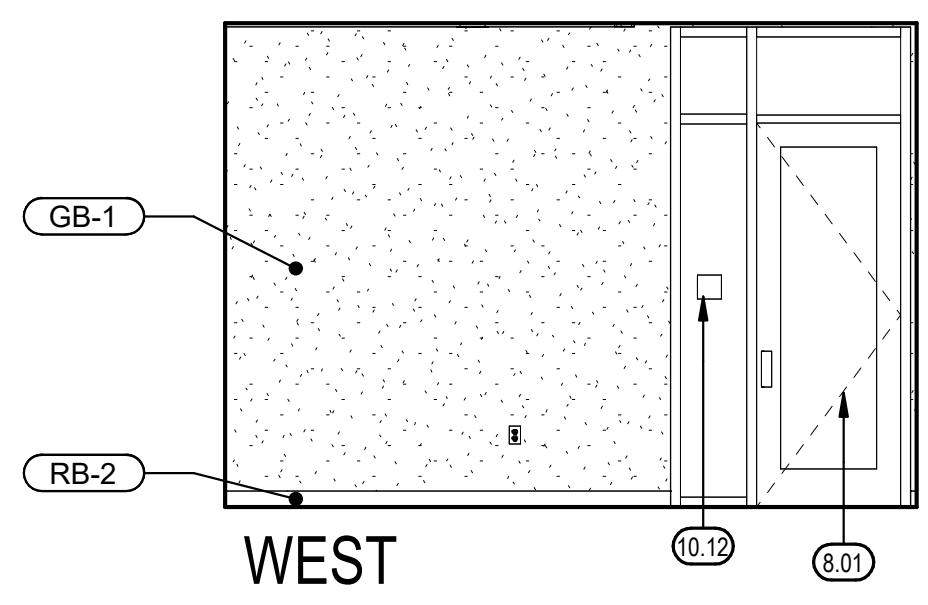
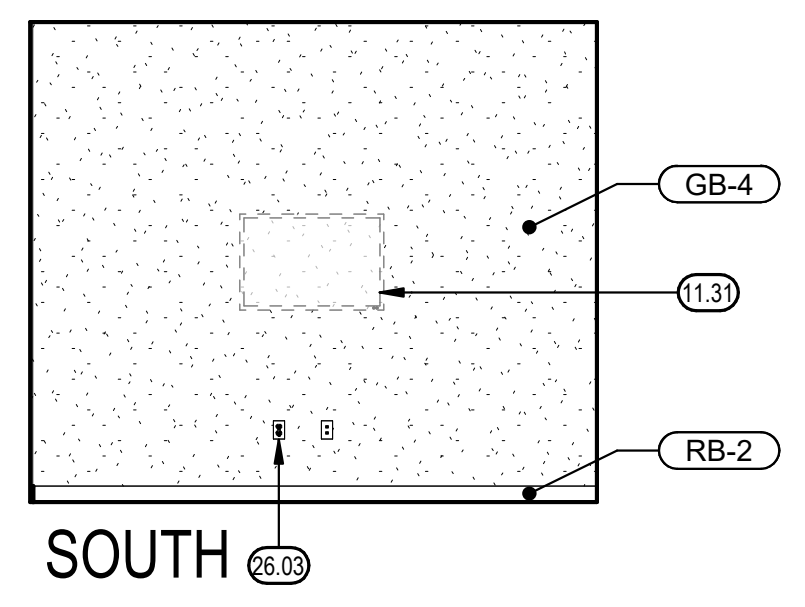
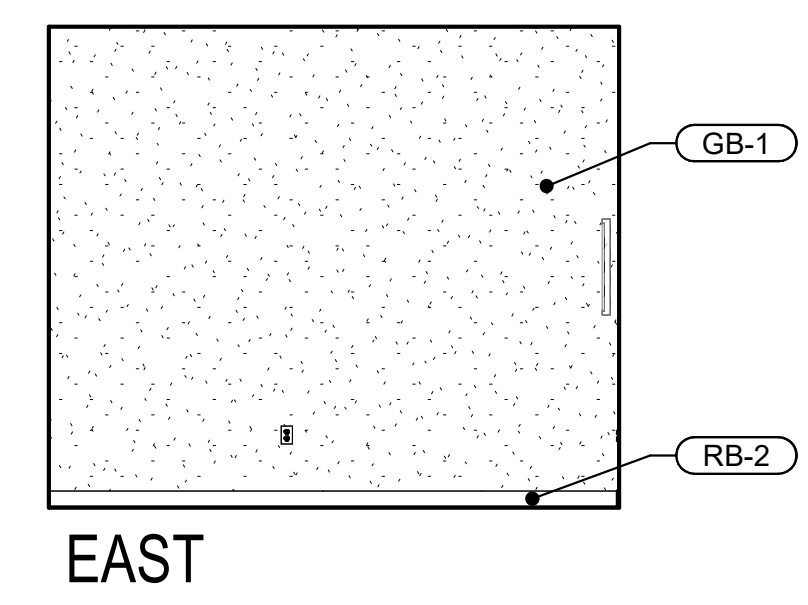

WAITING - A03 1/4" = 1'-0" 6

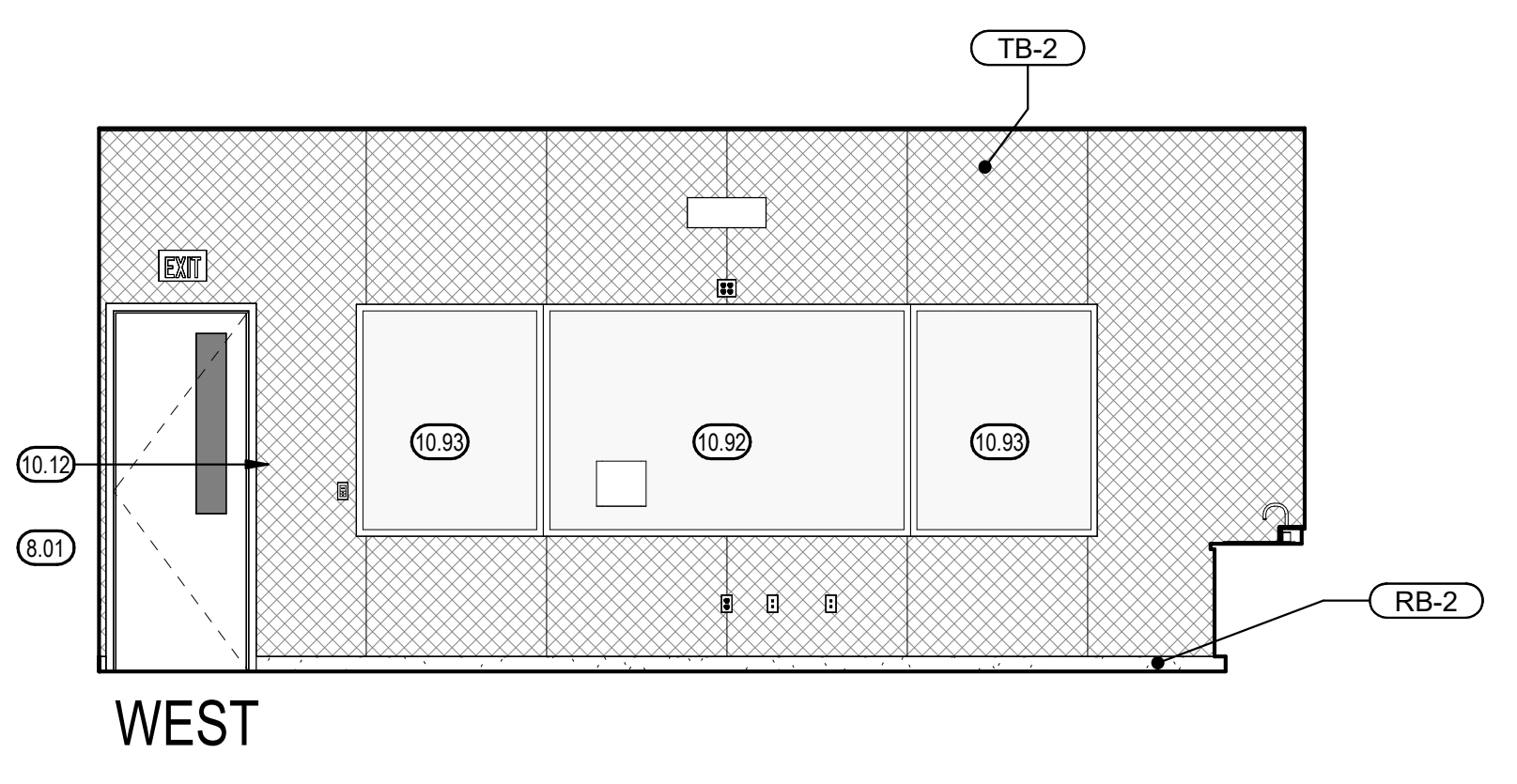
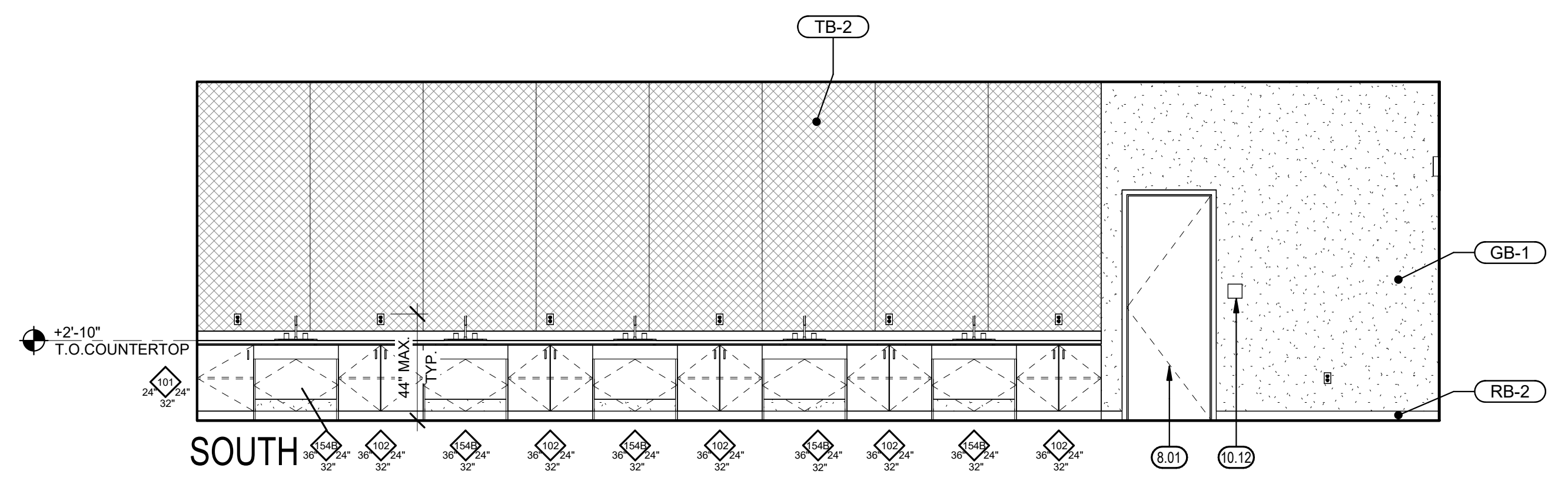
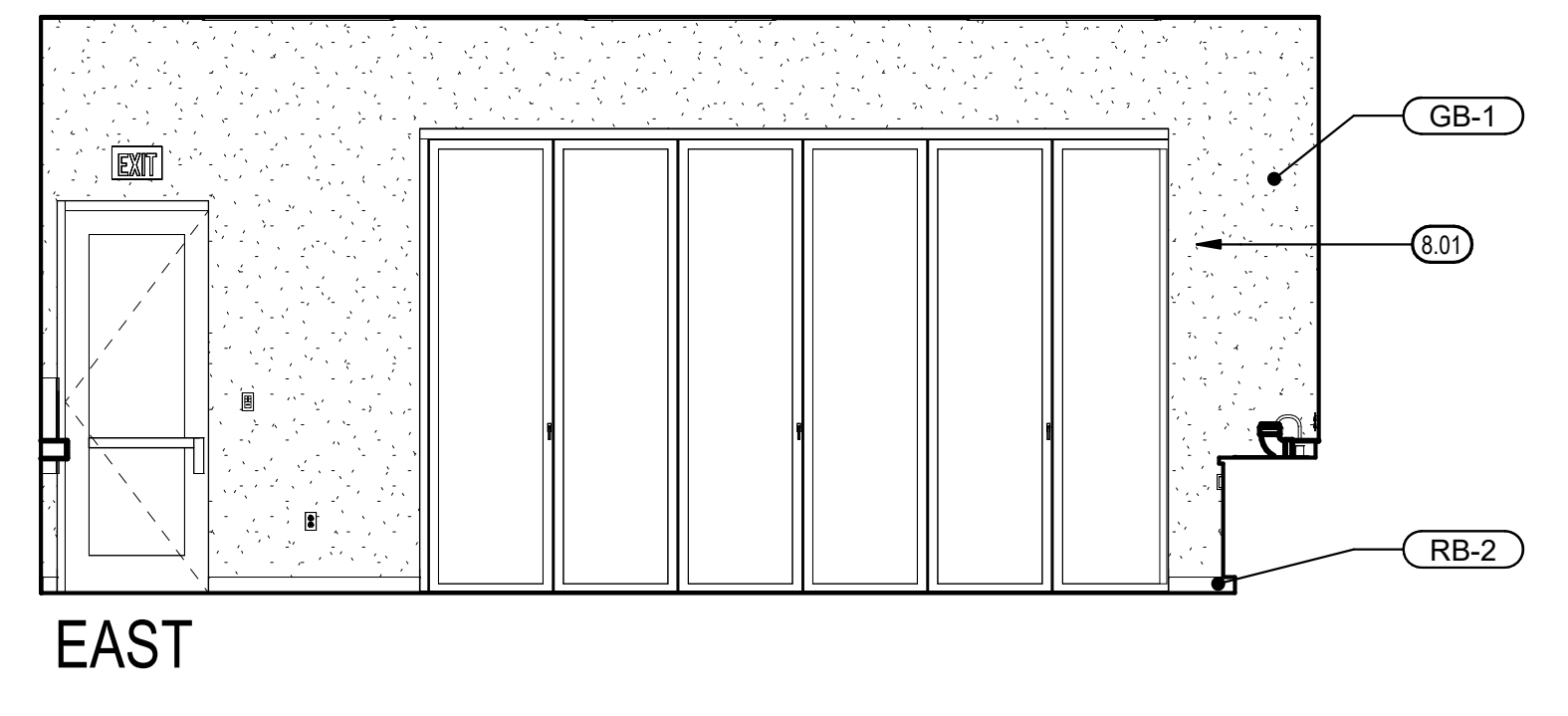
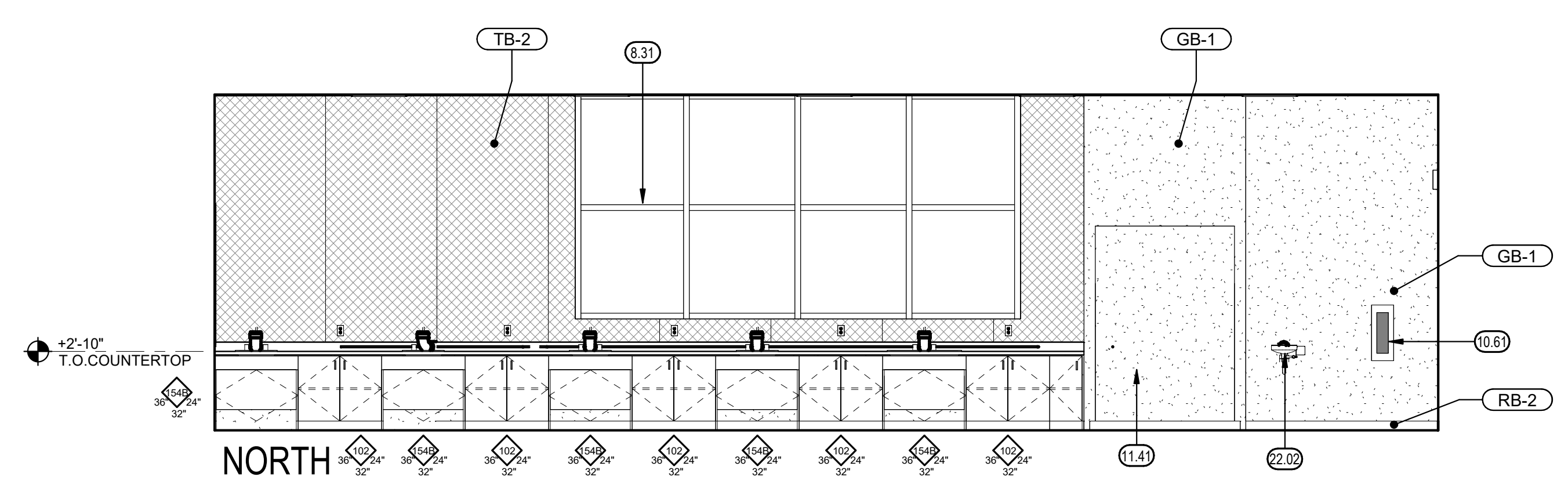

STEM - A04 1/4" = 1'-0" 8

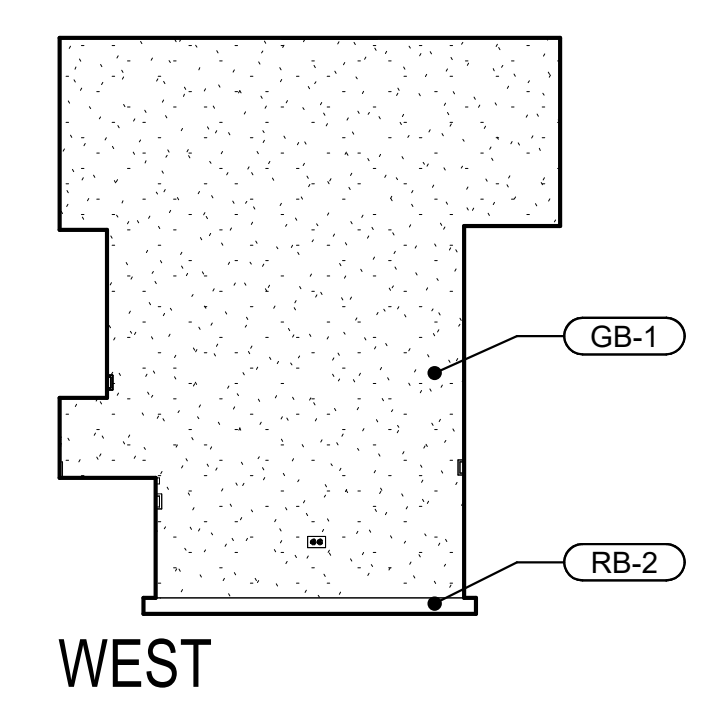
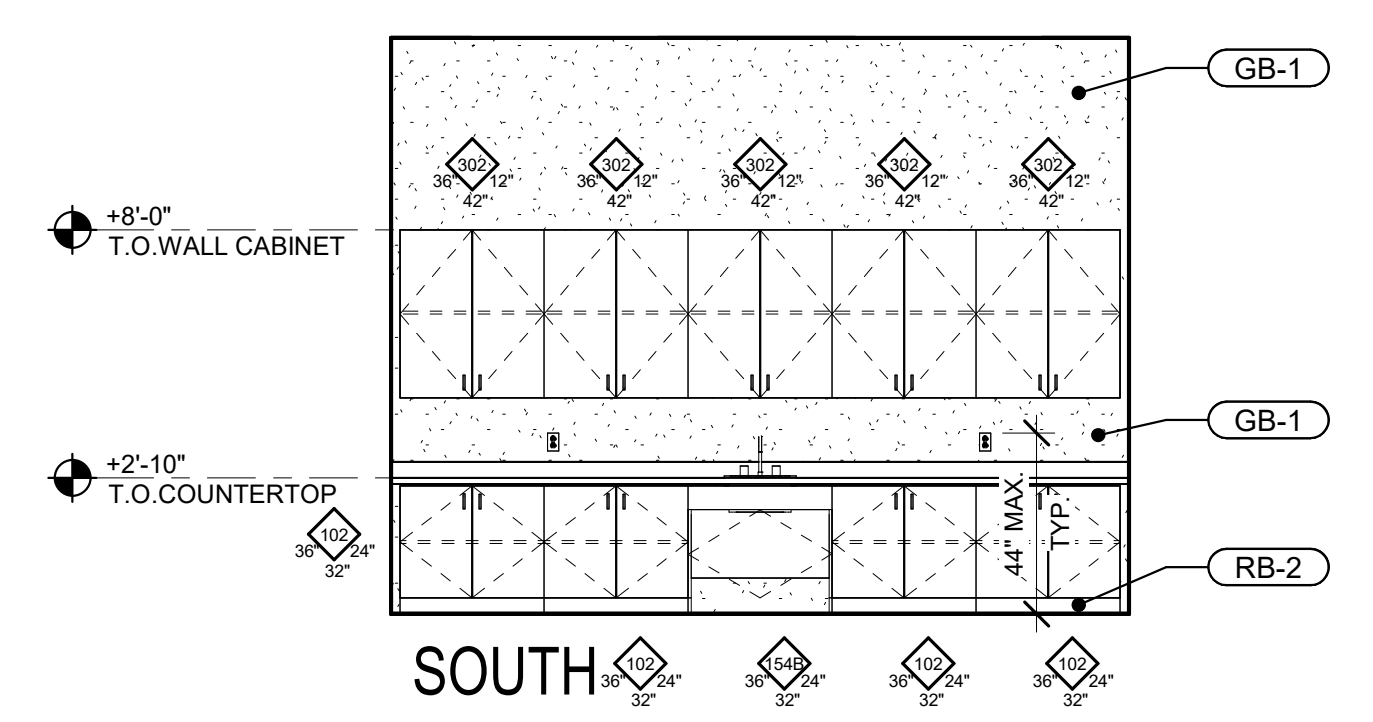
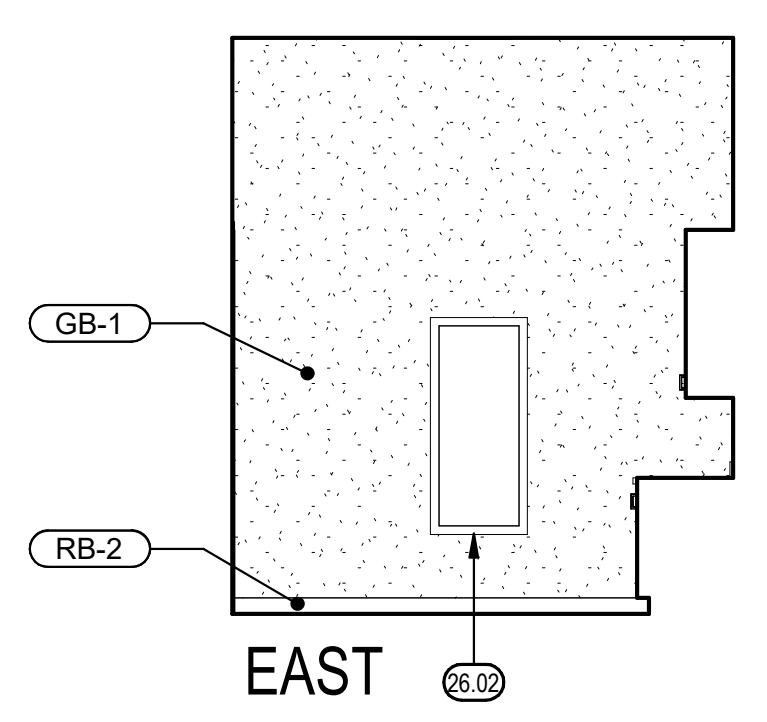
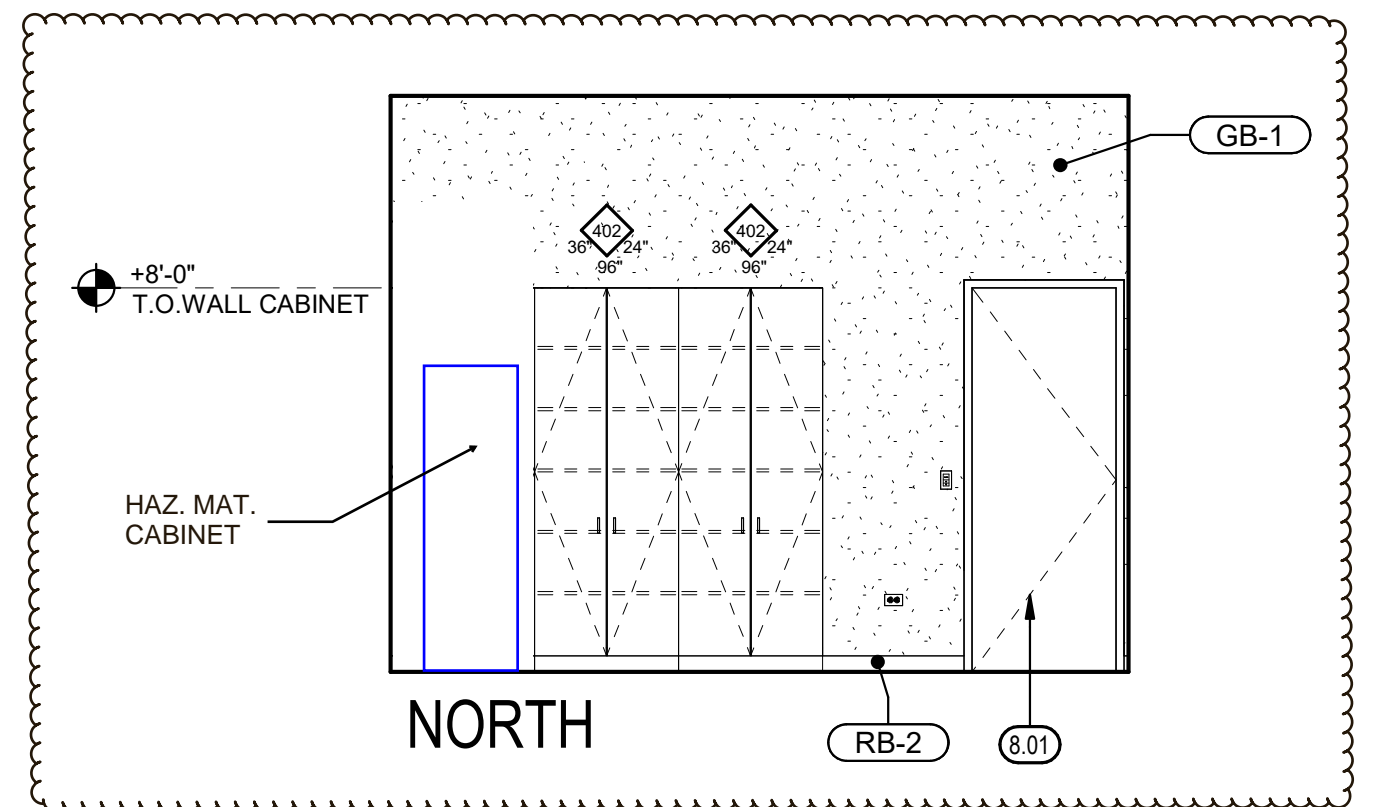

STEM PREP - A05 1/4" = 1'-0" 9

KEYNOTES 00.00

- 8.01 DOOR AND FRAME AS SCHEDULED
- 8.31 WINDOW AND FRAME AS SCHEDULED
- 10.12 ROOM IDENTIFICATION SIGNAGE, TYP. SEE DETAIL 3 / A801
- 10.61 FIRE EXTINGUISHER CABINET AND FIRE EXTINGUISHER
- 10.92 5X8' MARKERBOARD, SEE DETAIL 7 / A860
- 10.93 5X4' MARKERBOARD, SEE DETAIL 7 / A860
- 11.31 PROVIDE BACKING FOR OFOI MONITOR, SEE DETAILS 1/A860, 3/A860, 6/A860, & 12/A860
- 11.41 FUME HOOD SYSTEM, SEE MECHANICAL. FOR ANCHORAGE, SEE DETAIL
- 22.02 EMERGENCY EYE WASH, SEE PLUMBING
- 26.02 ELECTRICAL PANEL, SEE ELECTRICAL
- 26.03 WALL OUTLET, SEE ELECTRICAL, TYP.

IDENTIFICATION STAMP
DIV. OF THE STATE ARCHITECT
APP: 02-121813 INC.
REVIEWED FOR
SS FLS ACS
DATE: 09/28/2023

I, the undersigned, hereby certify that the above is a true and correct copy of the original drawing as submitted to me for review and approval. I am a duly licensed professional architect in the State of California, and my registration number is 12345. I am not to be held responsible for any errors or omissions on this drawing without my written authorization.

MARK	DATE	DESCRIPTION
	7/17/23	DSA BACKCHECK



TETER, INC.
FRESNO HEADQUARTERS
VISALIA | BAKERSFIELD | MADERA | SAN LUIS OBISPO
ARCHITECTS ENGINEERS CONNECTED

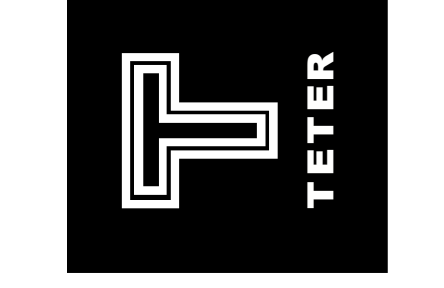

GENERAL NOTES

- A. PROVIDE BLOCKING FOR ALL WALL MOUNTED ACCESSORIES AND EQUIPMENT, TYP., SEE 1 / A860
- B. FOR ACCESSIBLE FIXTURE AND ACCESSORY MOUNTING HEIGHTS AND CLEARANCES, SEE 12 / A800, 3 / A800, AND 13 / A800
- C. FOR TYPICAL CASEWORK ANCHORAGE SEE 2 / A881
- D. FOR GRAB BAR ANCHORAGE SEE 9 / A800 AND 10 / A800
- E. FOR MIRROR ANCHORAGE SEE 19 / A800 AND 20 / A800
- F. SEE INTERIOR FINISH SCHEDULE A900 AND A940 FOR ADDITIONAL INFORMATION.

KEY PLAN

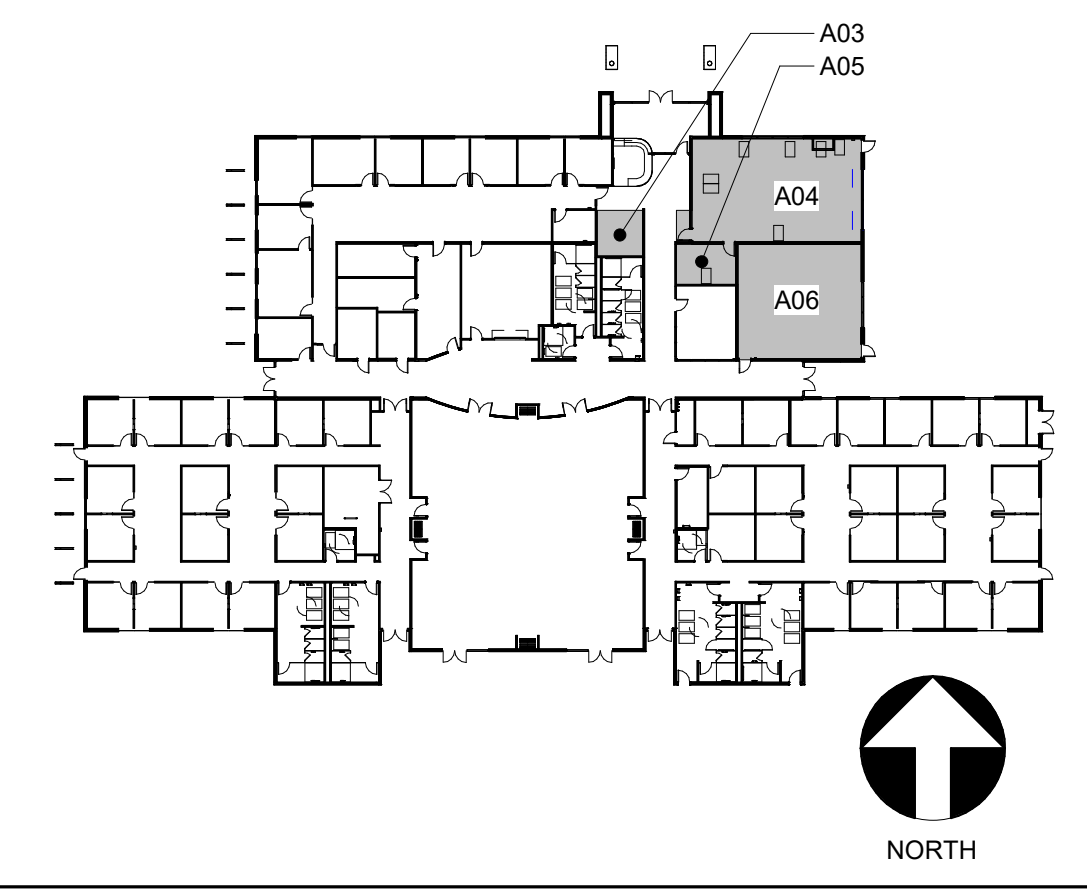

ONLINE SCHOOL & SPECIAL EDUCATION
ADMINISTRATION DISTRICT OFFICE EXPANSION
CLOVIS UNIFIED SCHOOL DISTRICT
CLOVIS, CA
DRAWING TITLE
INTERIOR ELEVATIONS - BLDG A - ONLINE SCHOOL

PROJECT NO.
12242.00
DRAWING
A911

\\net-files\1\Users\Elizabeth.Conti_TETRI\Documents\12242-A-DO_SITE_siticontieras.rvt

PLOT DATE: 9/13/2023 2:01:51 PM

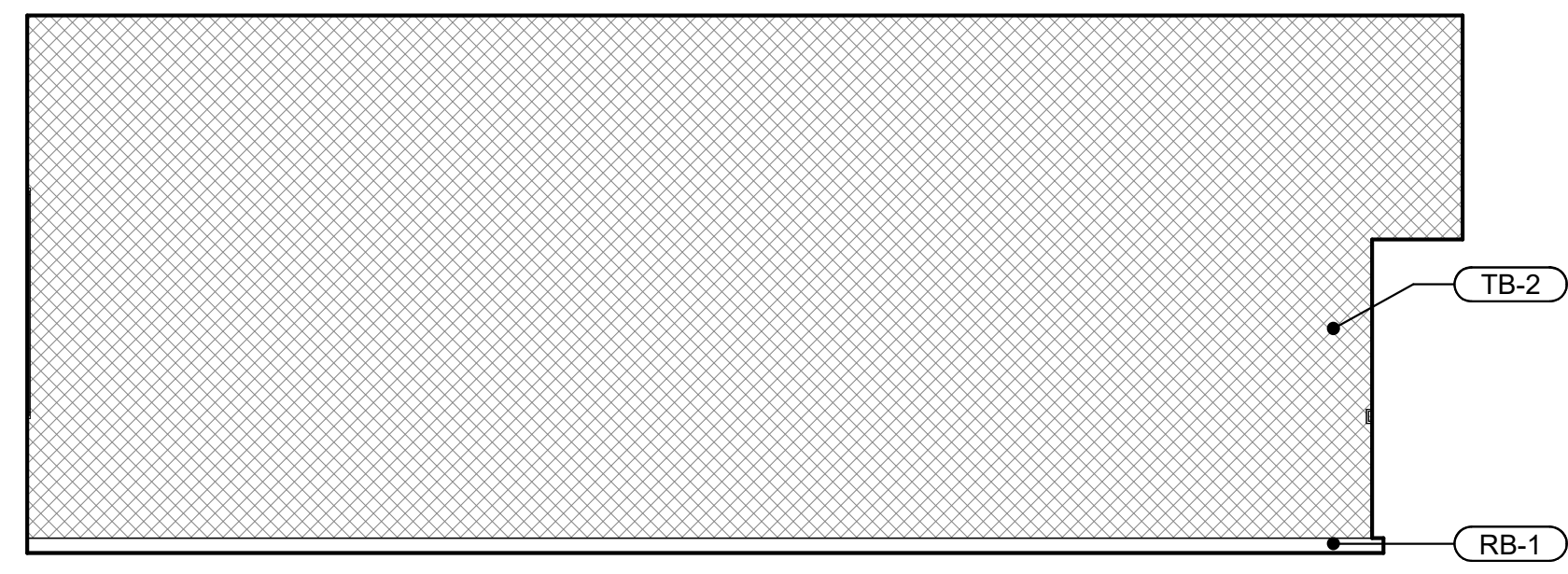

NORTH

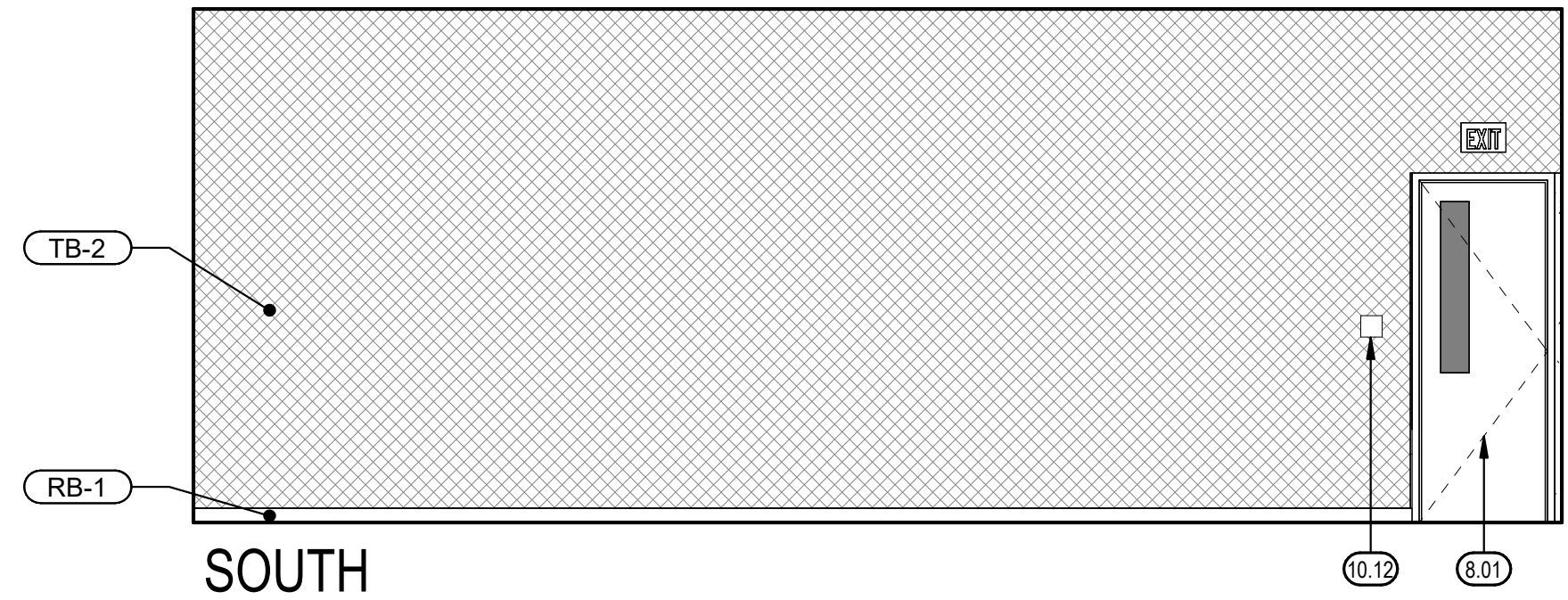

SOUTH

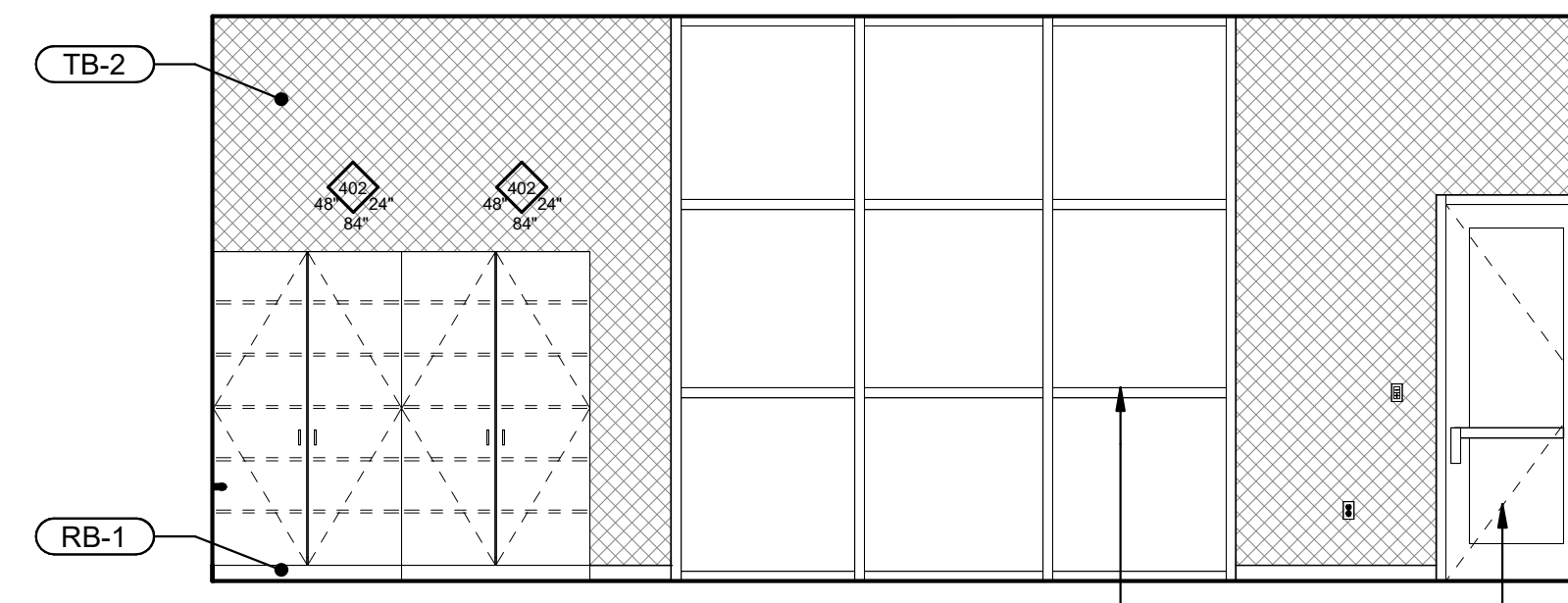

EAST

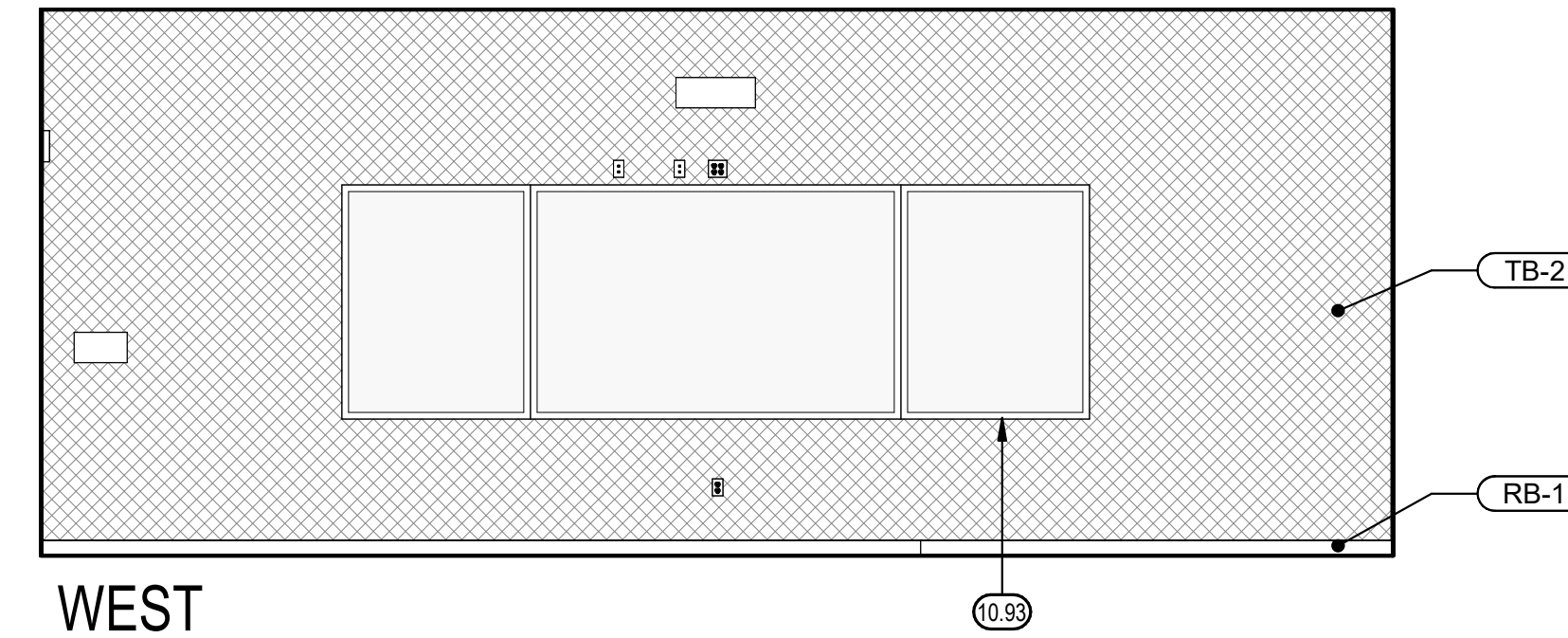

WEST

COMPUTER LAB - A06

1/4" = 1'-0" 7

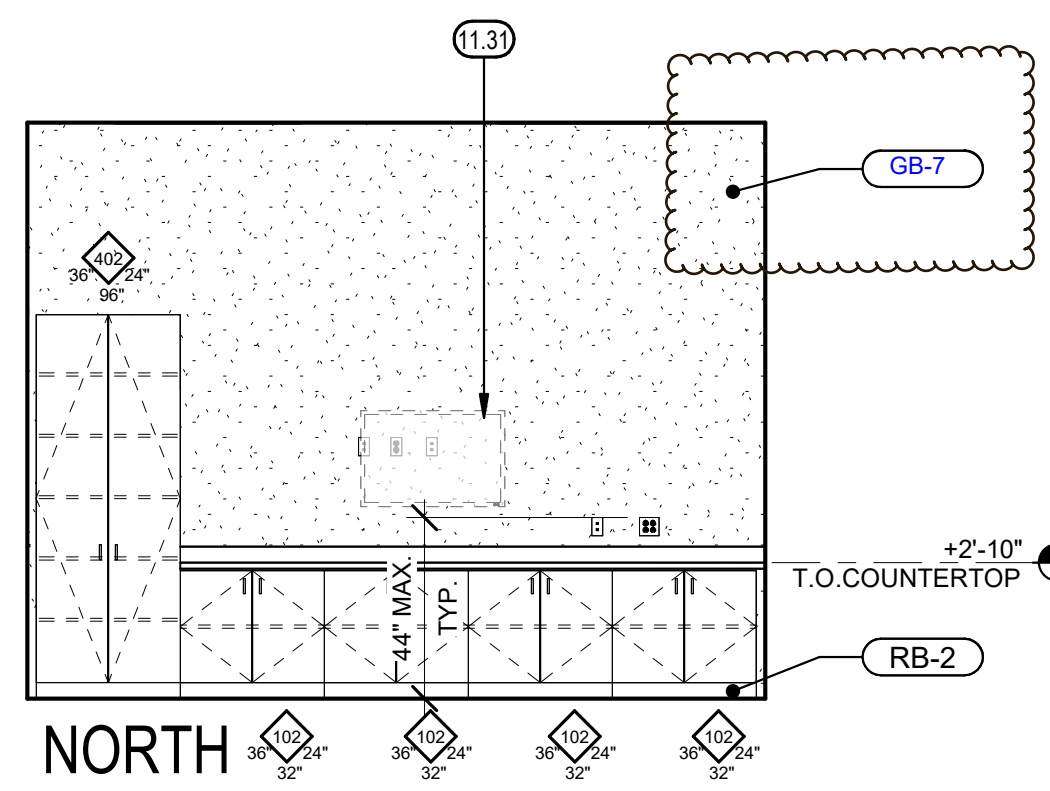

NORTH

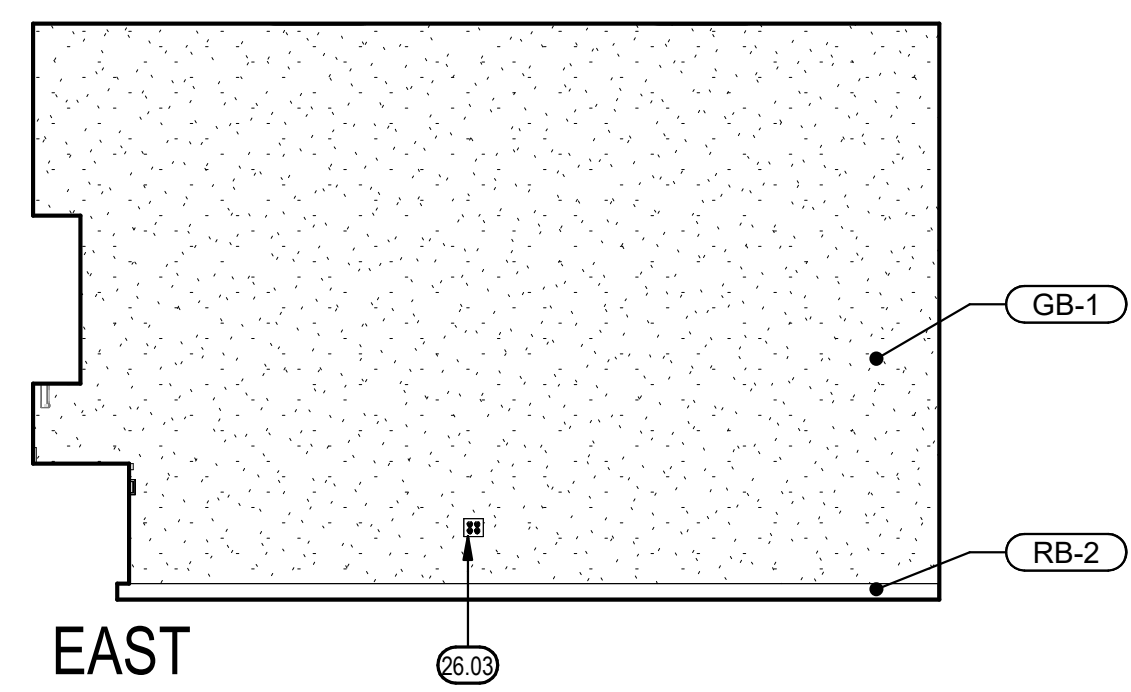

EAST

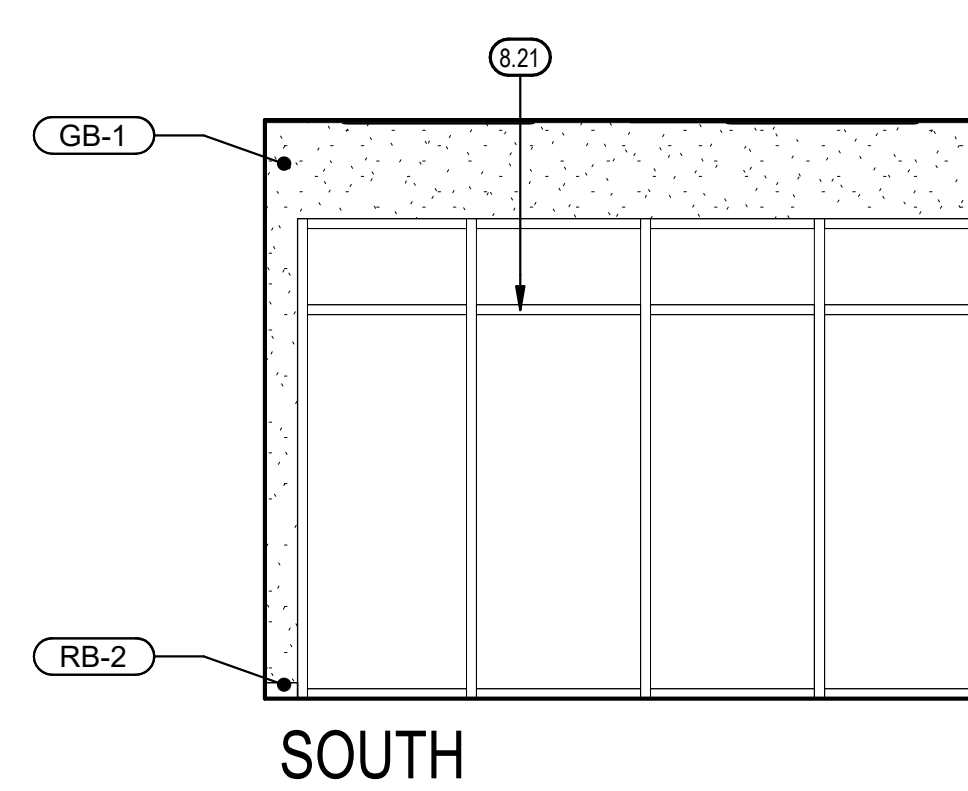

SOUTH

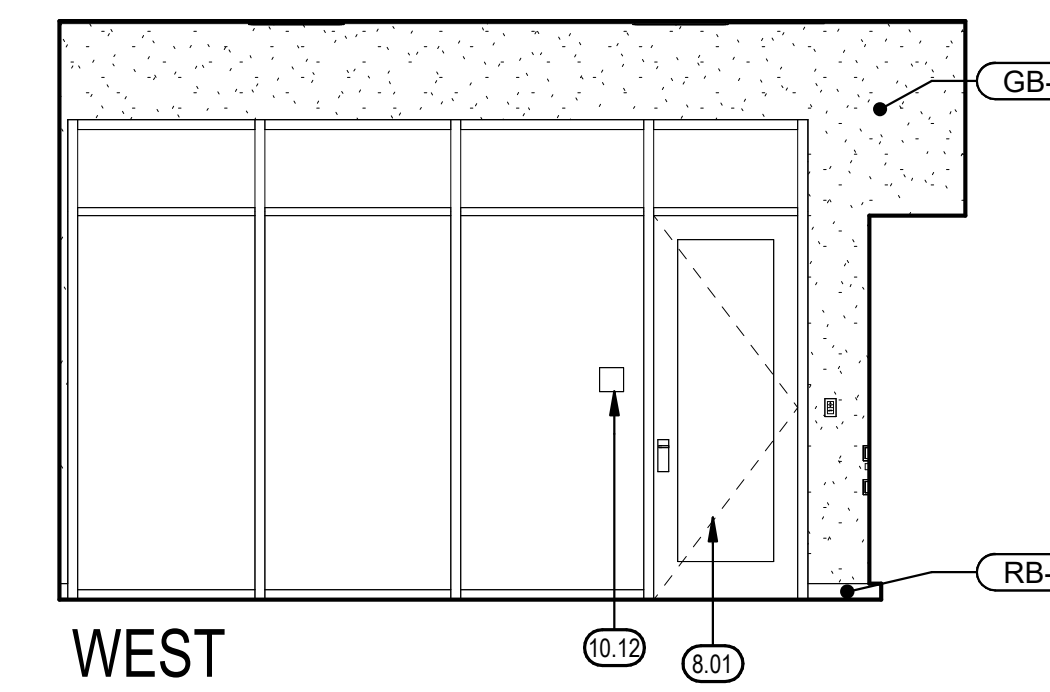

WEST

CONFERENCE - A07

1/4" = 1'-0" 8

KEYNOTES

- 8.01 DOOR AND FRAME AS SCHEDULED
- 8.21 ALUMINUM STOREFRONT
- 8.31 WINDOW AND FRAME AS SCHEDULED
- 10.12 ROOM IDENTIFICATION SIGNAGE, TYP. SEE DETAIL 3 / A801
- 10.92 5'X8' MARKERBOARD, SEE DETAIL 7 / A860
- 10.93 5'X4' MARKERBOARD, SEE DETAIL 7 / A860
- 11.31 PROVIDE BACKING FOR OFI MONITOR, SEE DETAILS 1/A860, 3/A860, 5/A860, & 12/A860
- 26.03 WALL OUTLET, SEE ELECTRICAL, TYP.

IDENTIFICATION STAMP
 DIV. OF THE STATE ARCHITECT
 APP: 02-121813 INC.
 REVIEWED FOR:
 SS FLS ACS
 DATE: 09/28/2023

I hereby certify that the above is a true and correct copy of the original drawing as submitted to me for review and approval. I am a duly licensed professional architect in the State of California. My commission expires on 09/30/2024.

MARK	DATE	DESCRIPTION
	7/17/23	DSA BACKCHECK



TETER, INC.
 ARCHITECTS ENGINEERS CONNECTED
 FRESNO HEADQUARTERS
 VISALIA | BAKERSFIELD | MADERA | SAN LUIS OBISPO

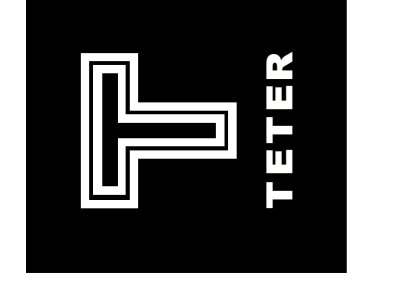

GENERAL NOTES

- A. PROVIDE BLOCKING FOR ALL WALL MOUNTED ACCESSORIES AND EQUIPMENT, TYP. SEE 1 / A860
- B. FOR ACCESSIBLE FIXTURE AND ACCESSORY MOUNTING HEIGHTS AND CLEARANCES, SEE 12 / A800, 3 / A800, AND 13 / A800
- C. FOR TYPICAL CASEWORK ANCHORAGE SEE 2 / A861
- D. FOR GRAB BAR ANCHORAGE SEE 9 / A800 AND 10 / A800
- E. FOR MIRROR ANCHORAGE SEE 19 / A800 AND 20 / A800
- F. SEE INTERIOR FINISH SCHEDULE A800 AND A940 FOR ADDITIONAL INFORMATION.

KEY PLAN

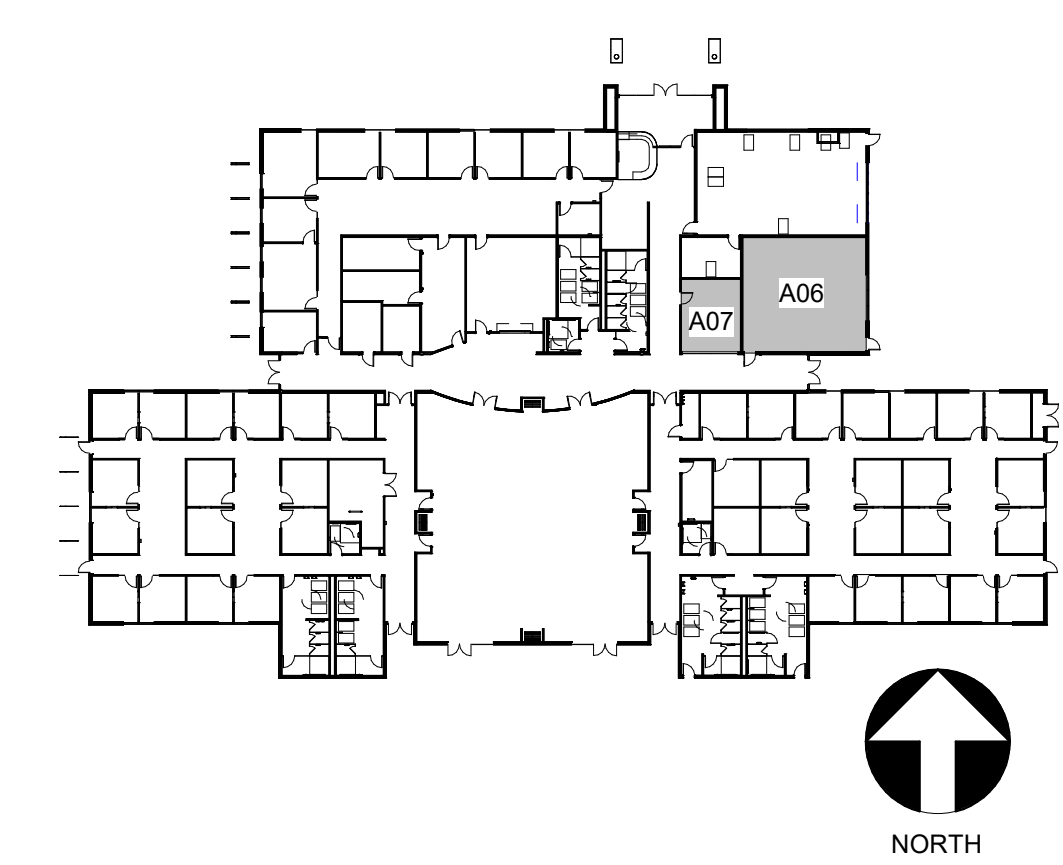

ONLINE SCHOOL & SPECIAL EDUCATION
 ADMINISTRATION DISTRICT OFFICE EXPANSION
 CLOVIS UNIFIED SCHOOL DISTRICT
 CLOVIS, CA
 DRAWING TITLE
 INTERIOR ELEVATIONS - BLDG A - ONLINE SCHOOL

PROJECT NO.
 12242.00
 DRAWING
A912

\\net-files1\Users\Elizabeth.Conti_TETRI\Documents\12242-A-DO_SITE_siticontainers.rvt

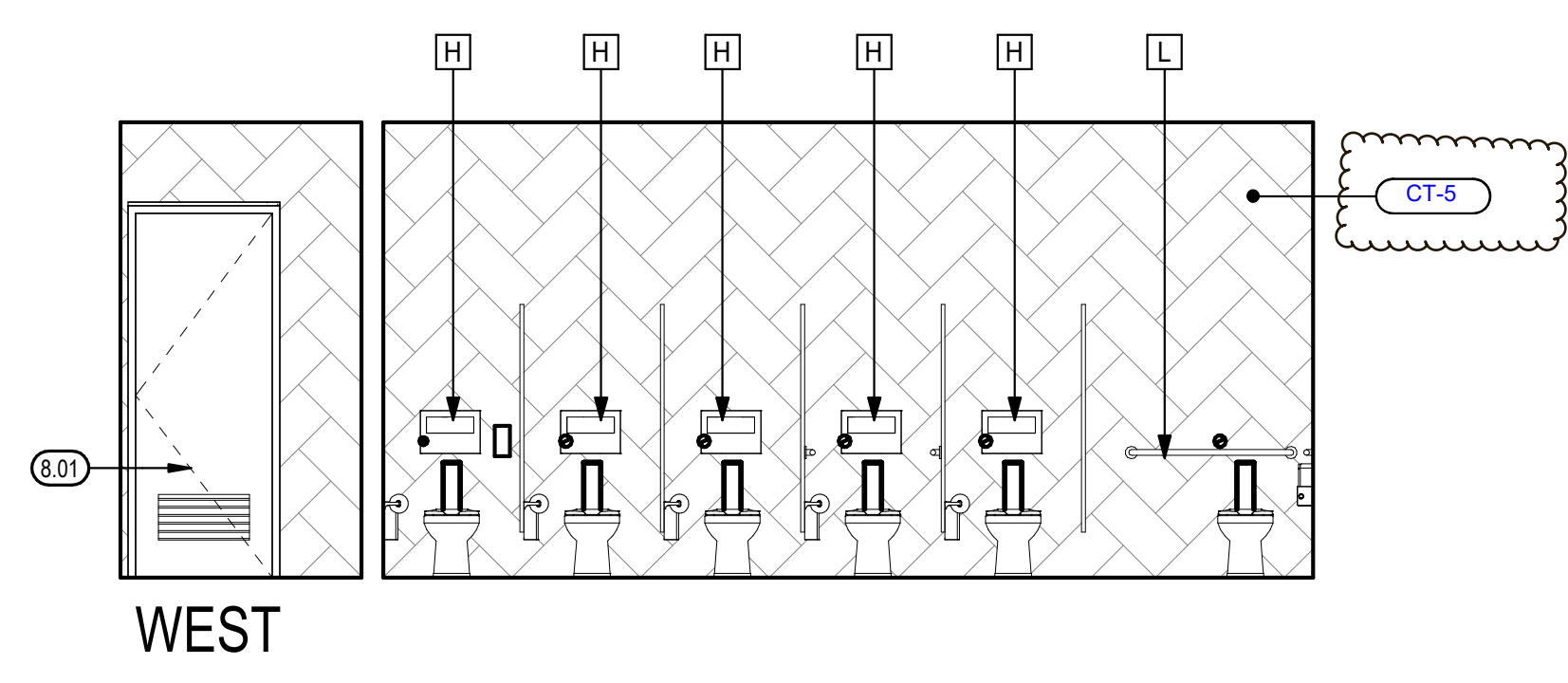
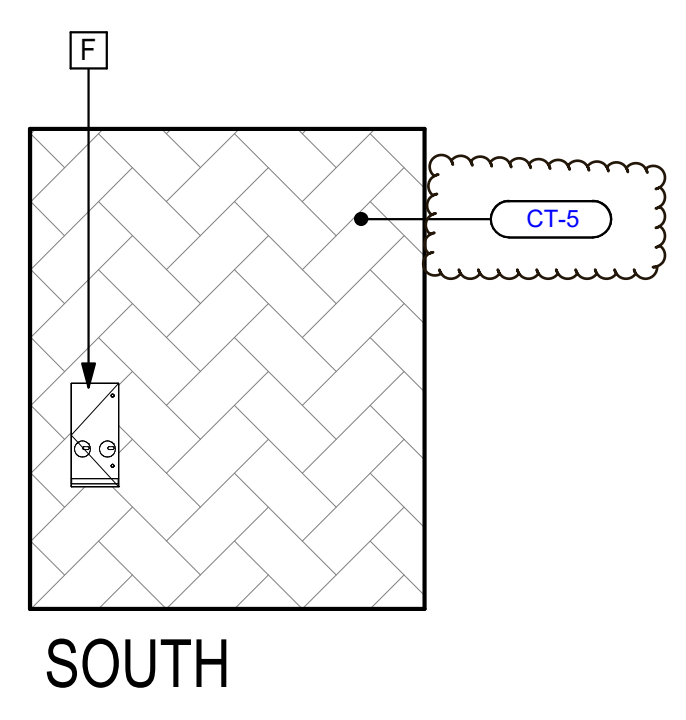
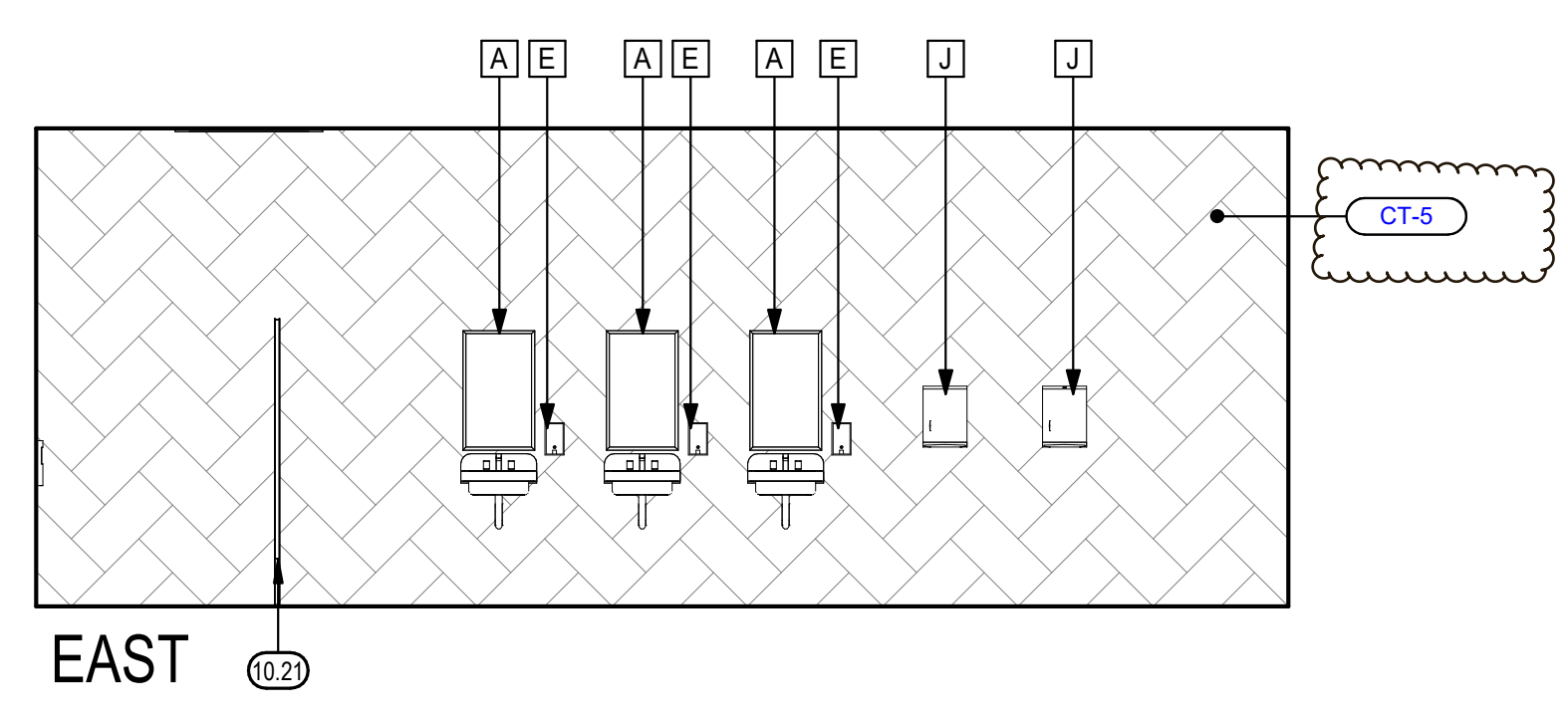
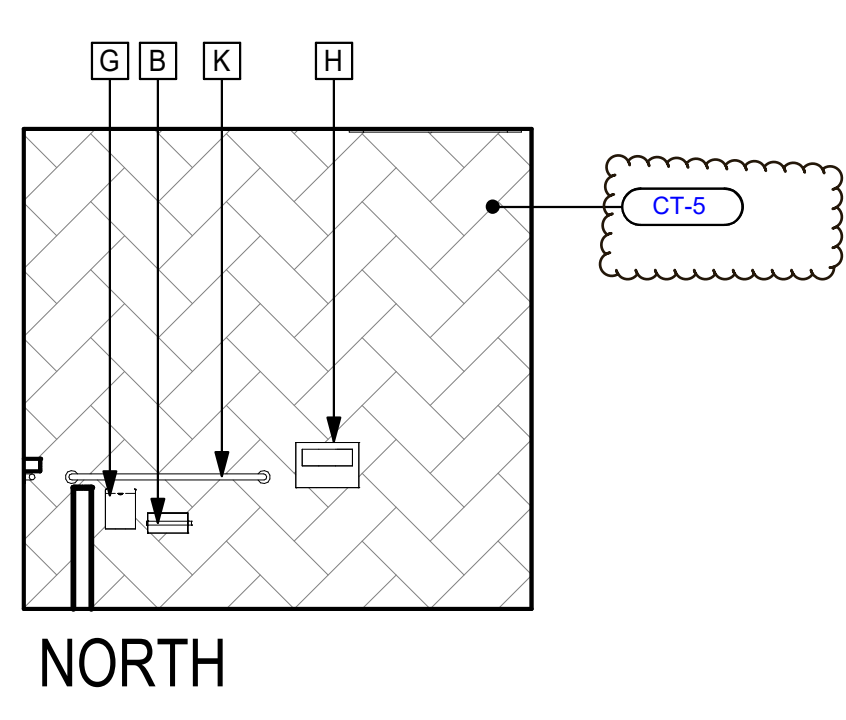

WOMEN - A09 1/4" = 1'-0" 6

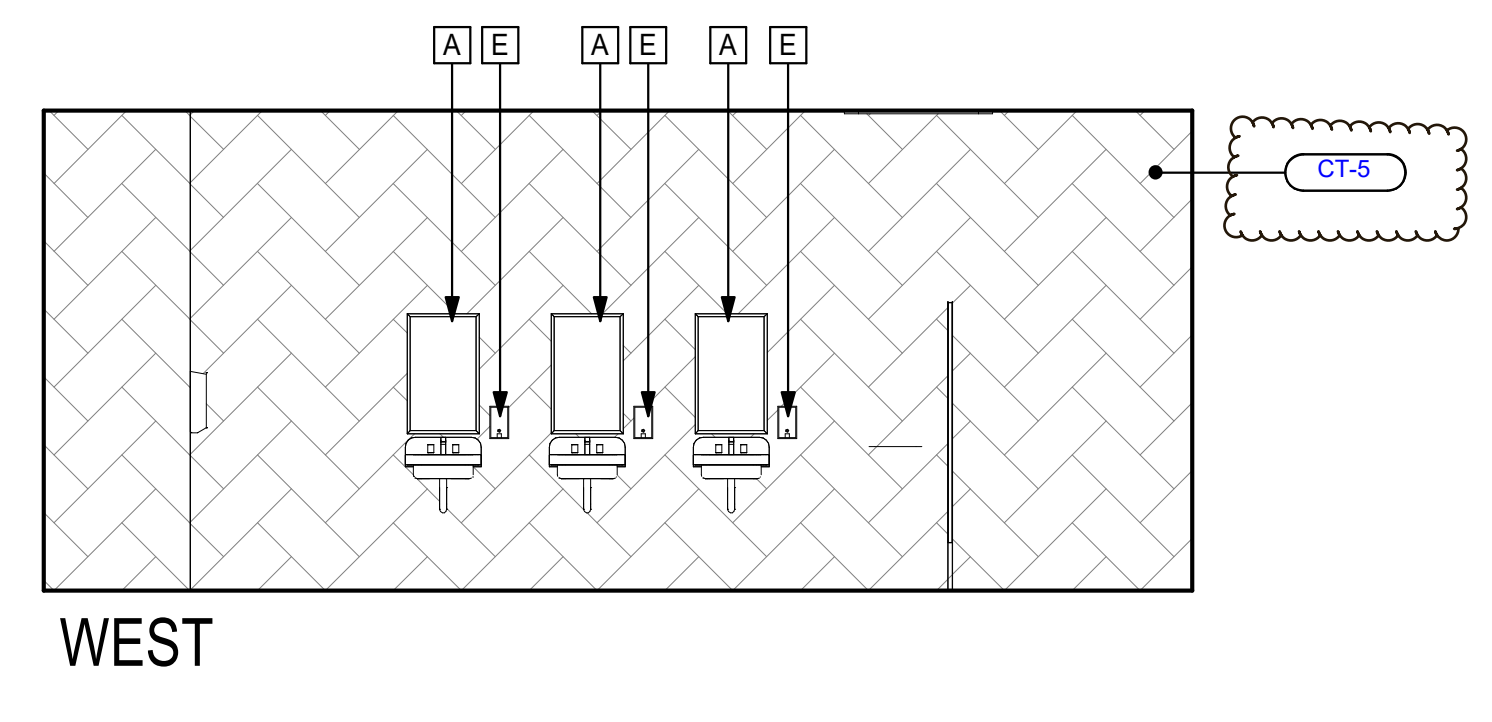
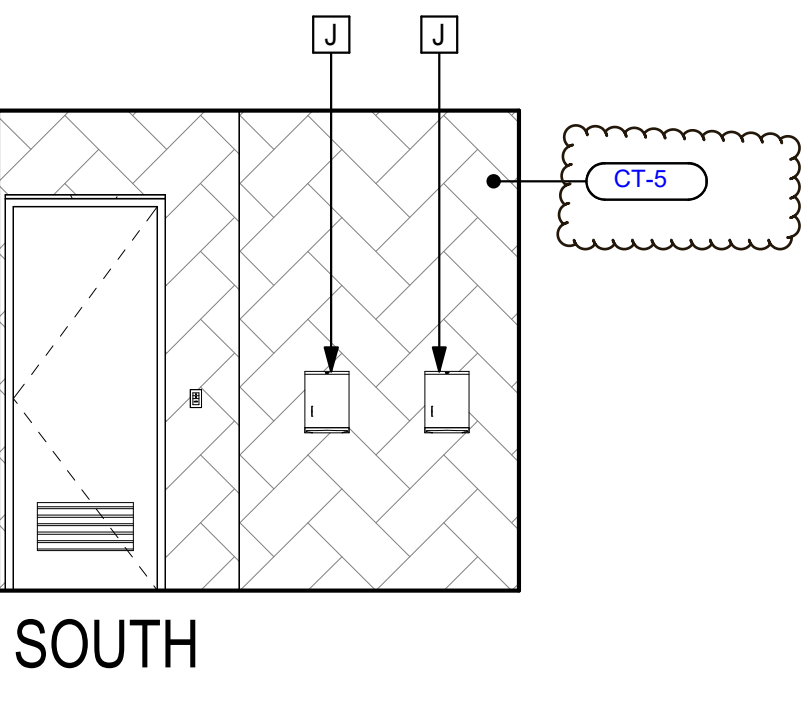
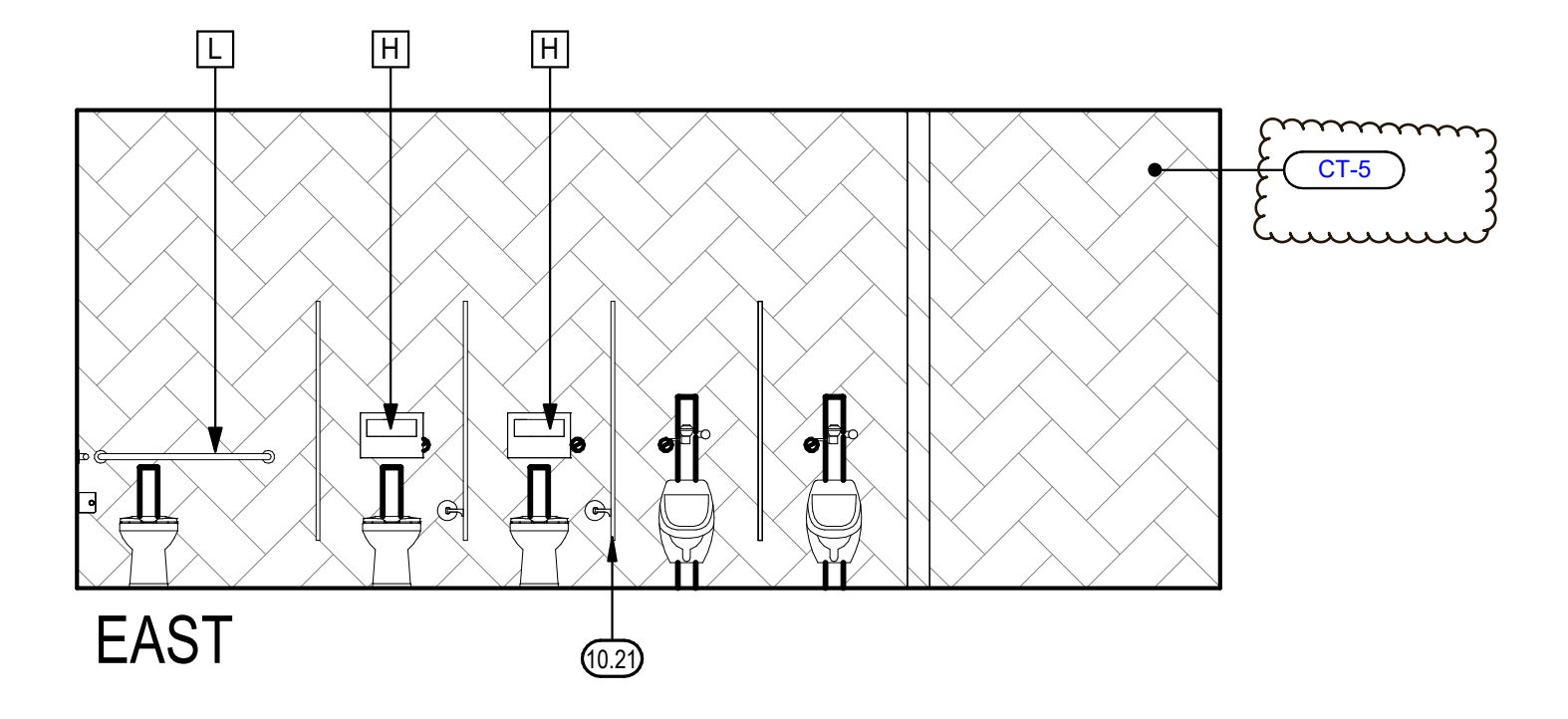
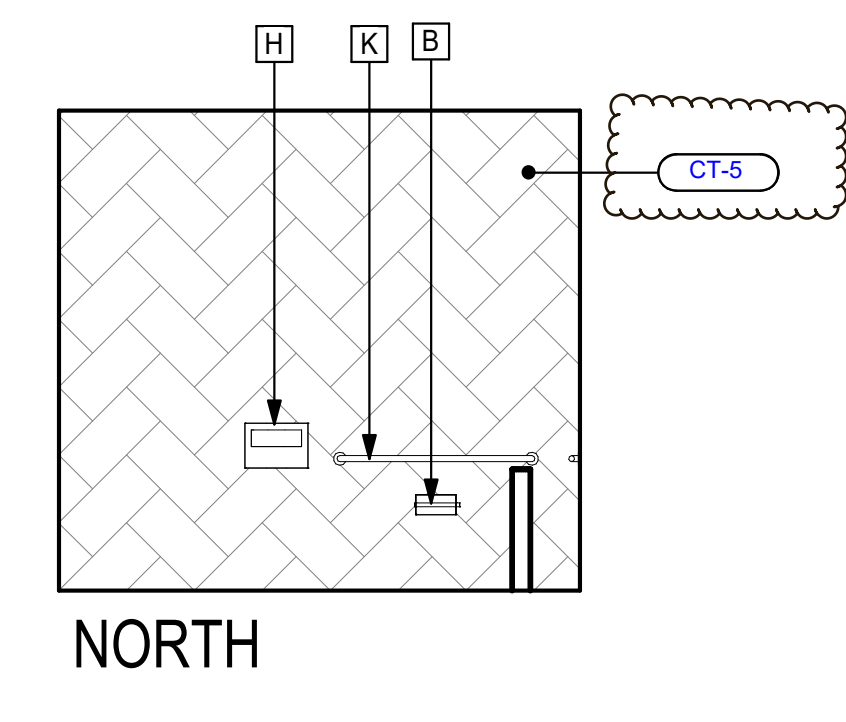

MEN - A10 1/4" = 1'-0" 7

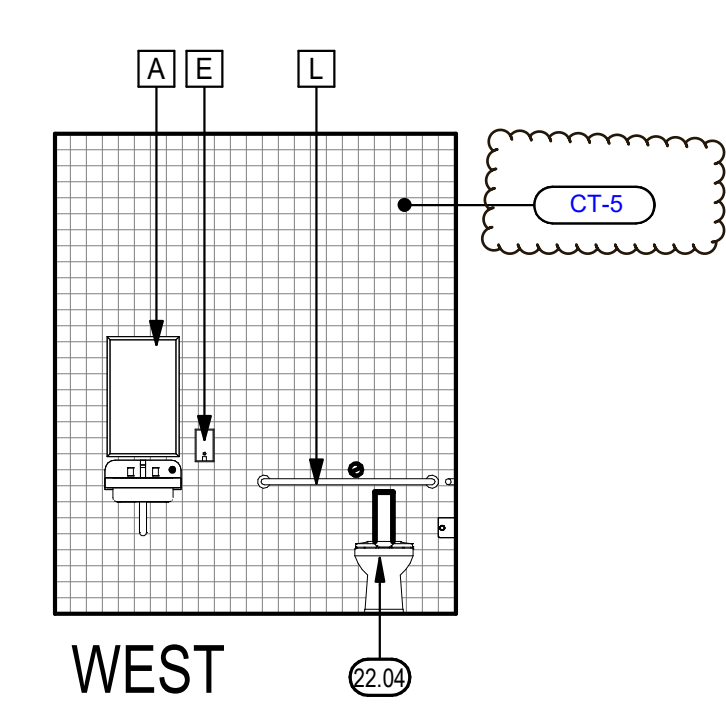
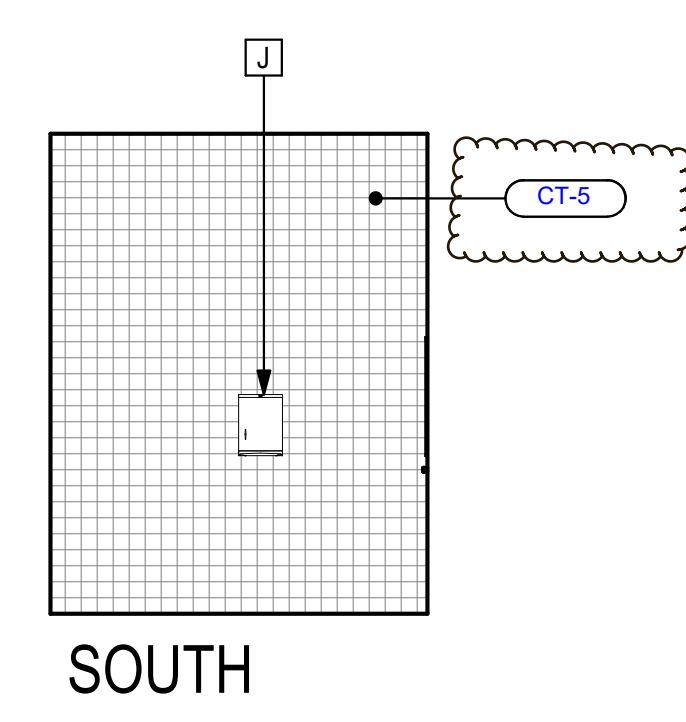
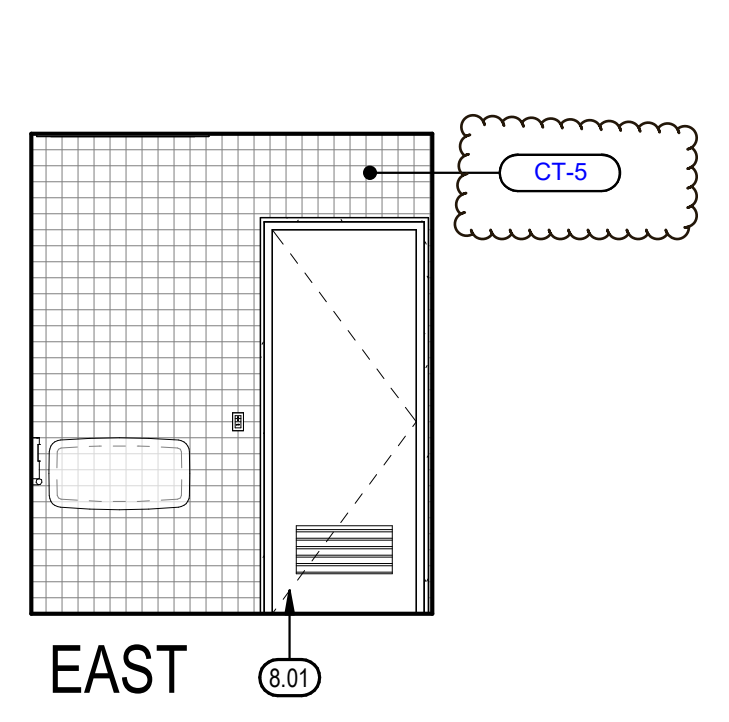
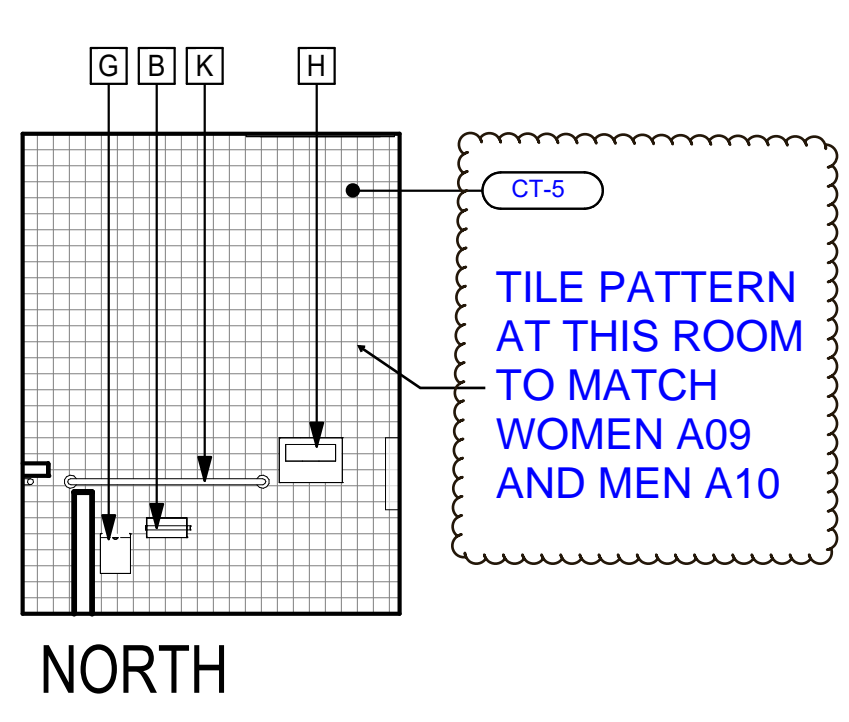

UNISEX - A11 1/4" = 1'-0" 8

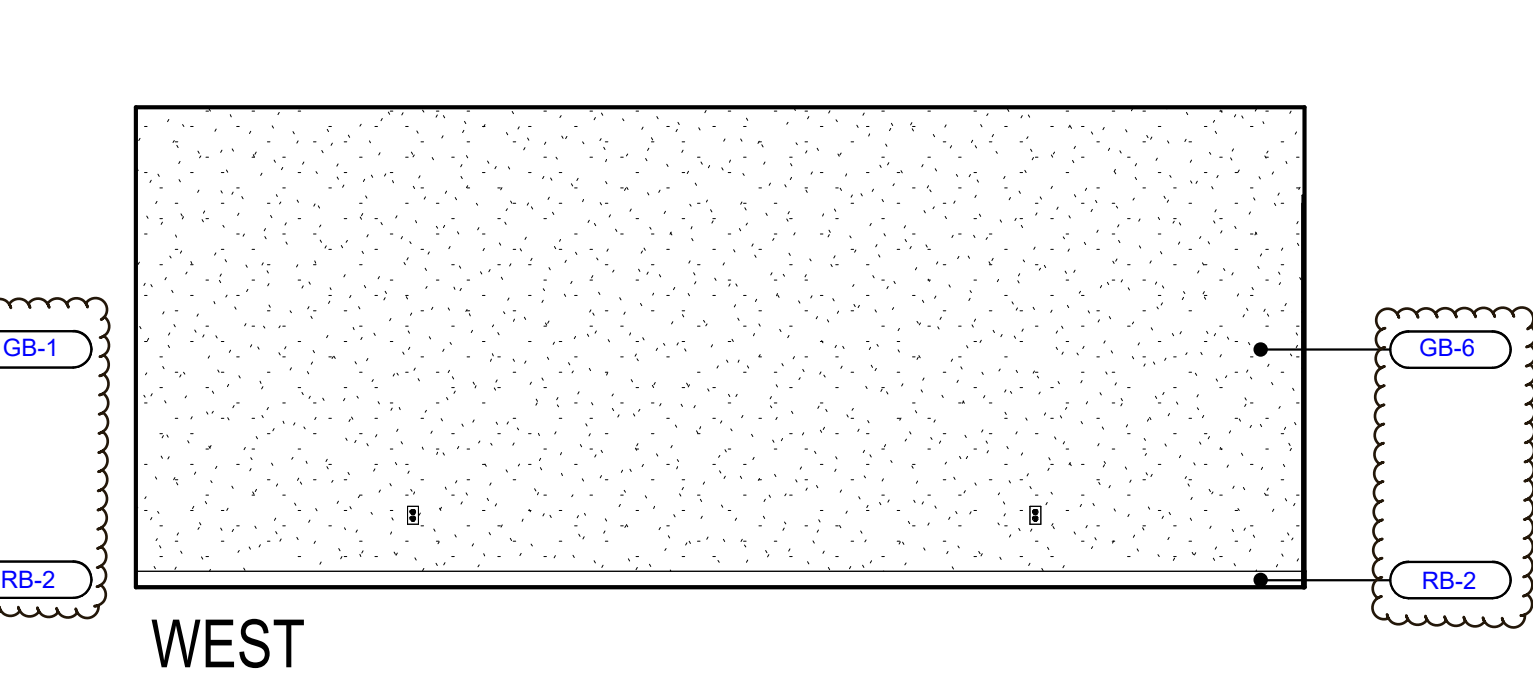
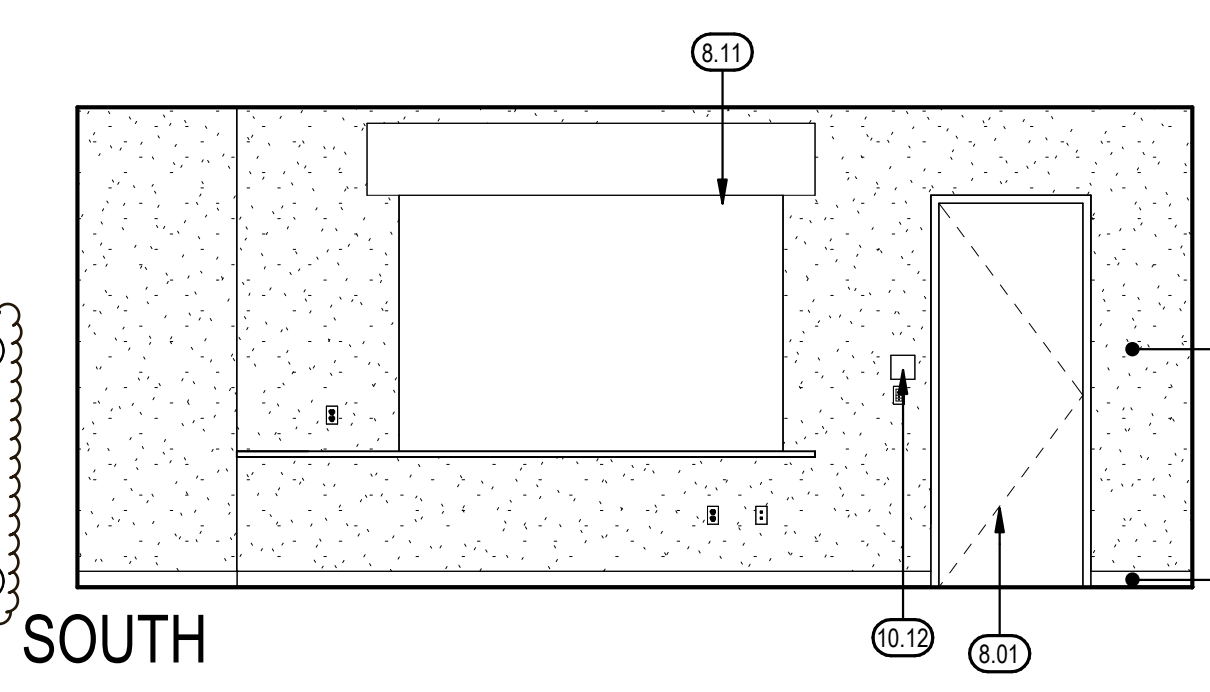
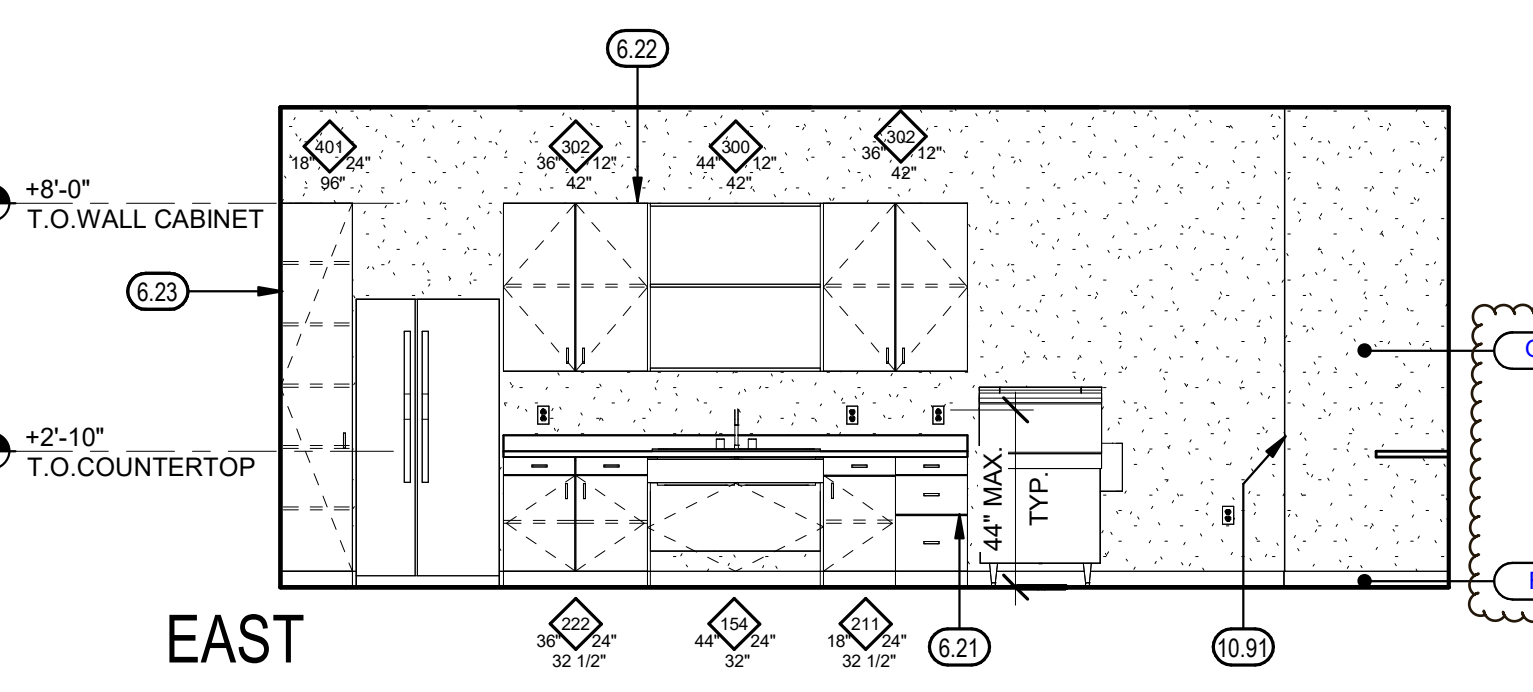
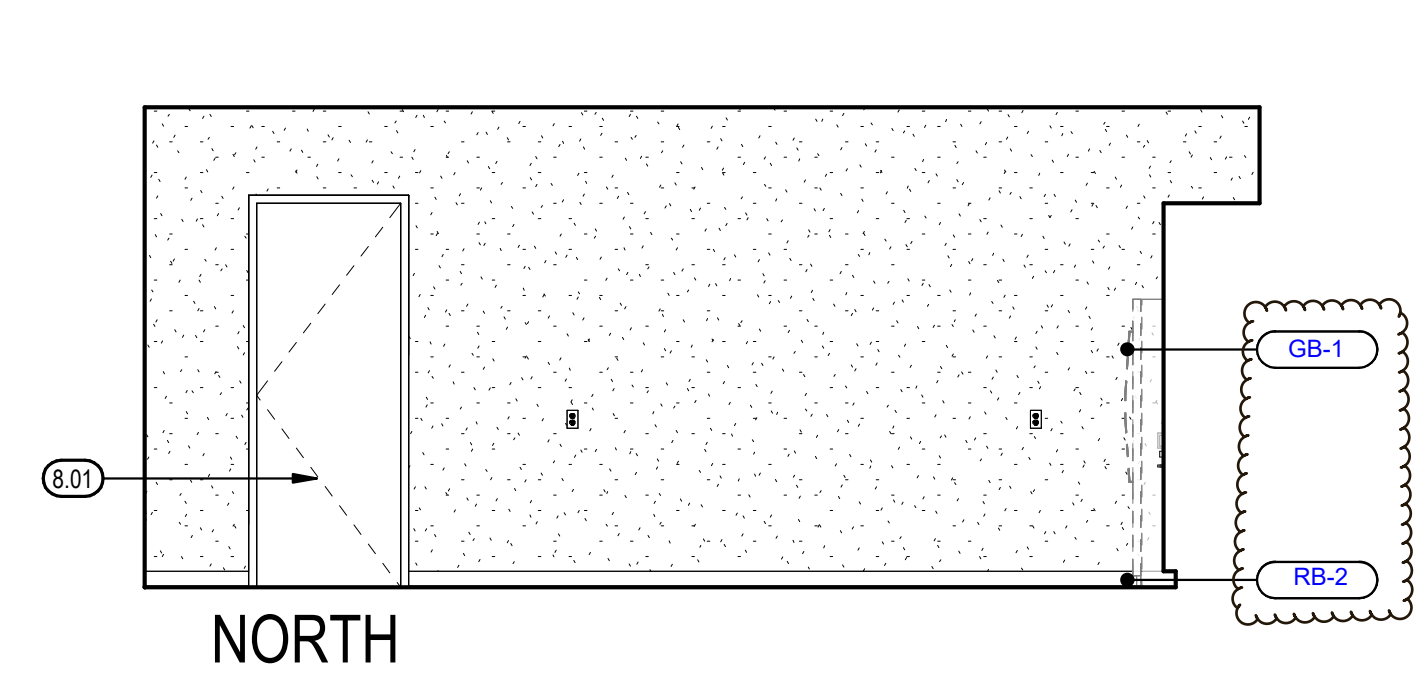

LOUNGE - A12 1/4" = 1'-0" 9

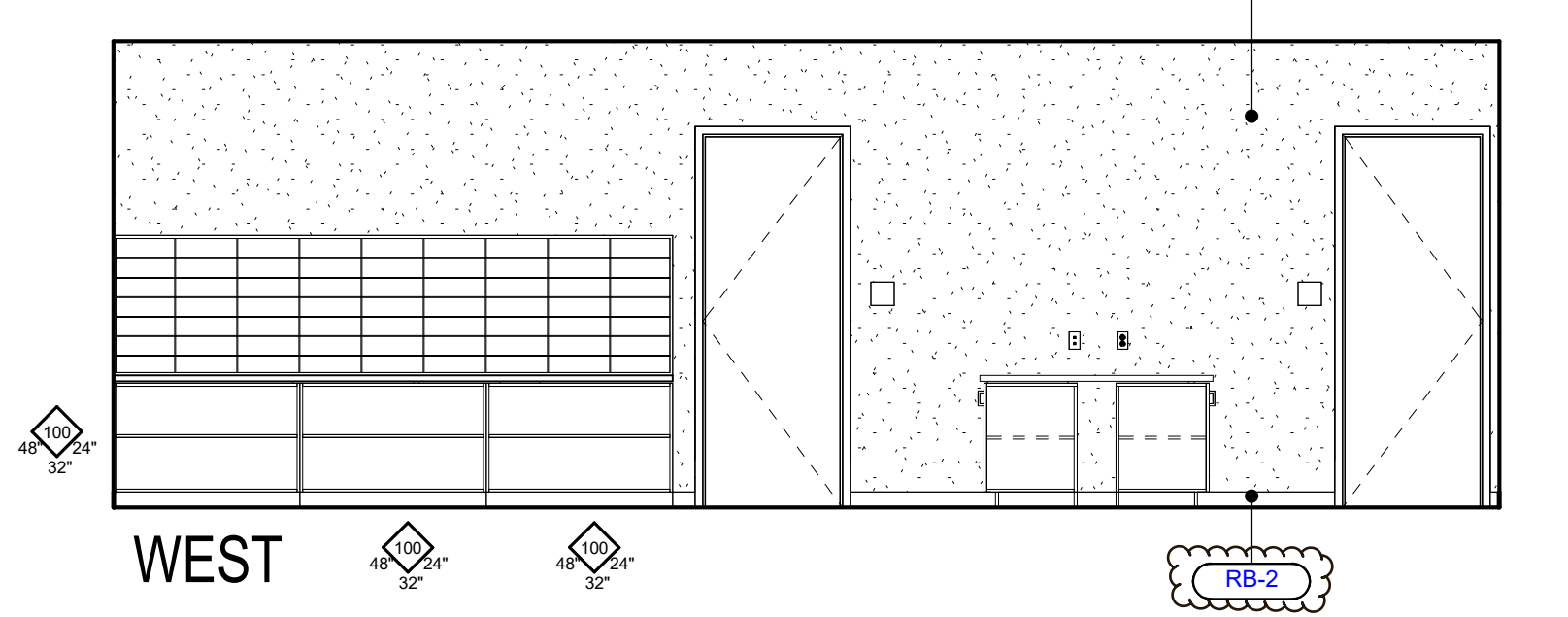
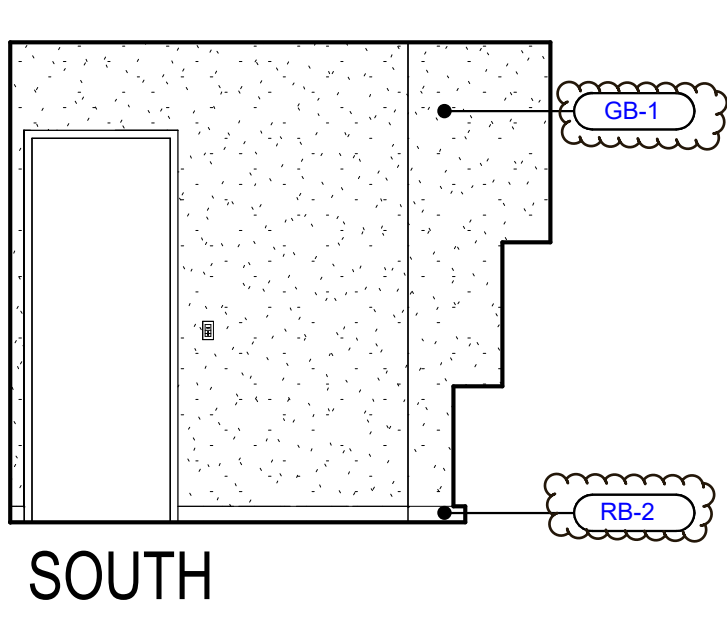
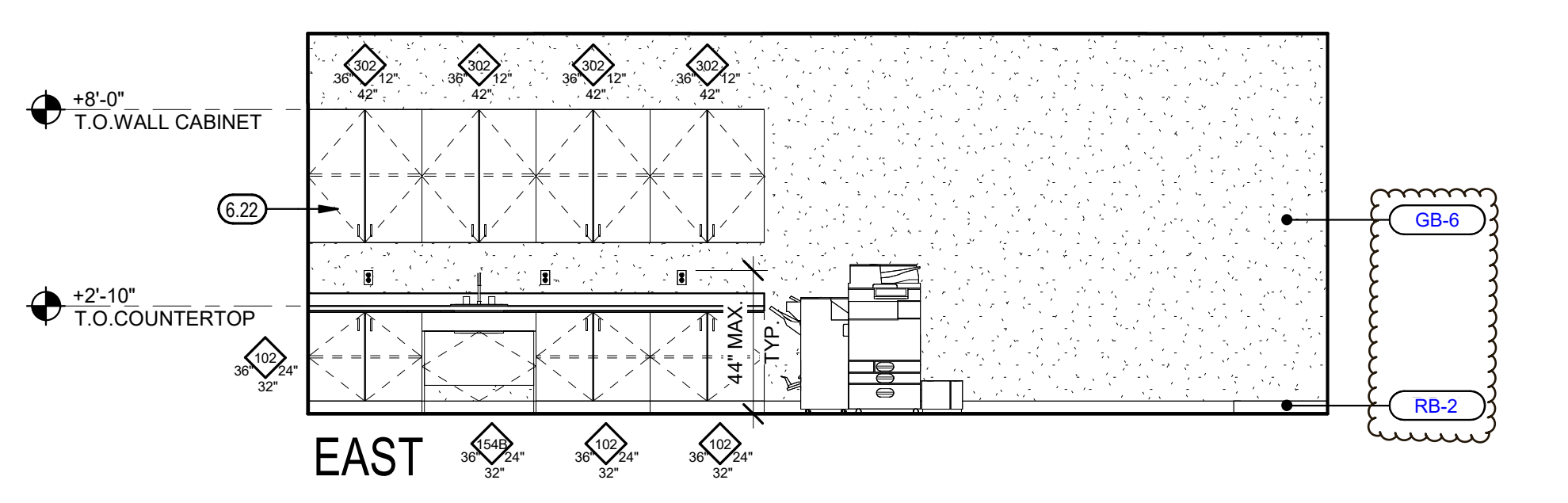
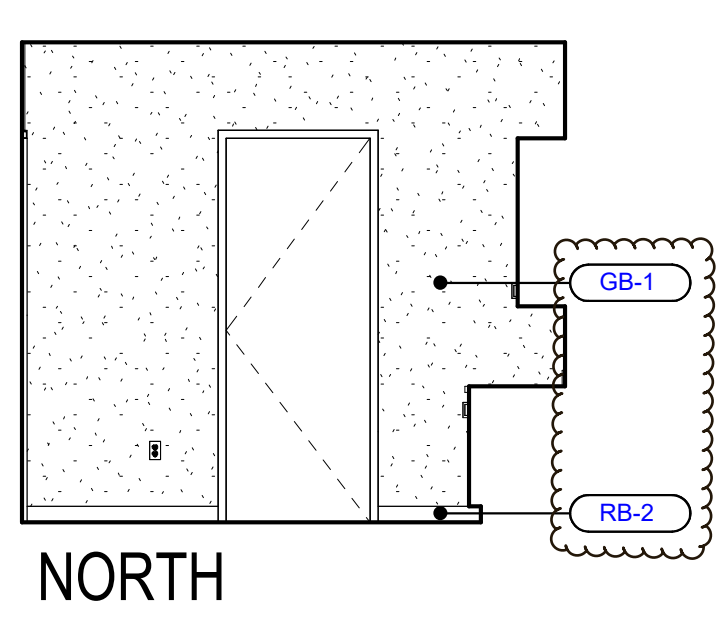

WORKROOM - A13 1/4" = 1'-0" 10

KEYNOTES

- 6.21 PLASTIC LAMINATE BASE CABINET
- 6.22 PLASTIC LAMINATE UPPER CABINET
- 6.23 PLASTIC LAMINATE TALL STORAGE CABINET, SEE DETAIL 3 / A861
- 8.01 DOOR AND FRAME AS SCHEDULED
- 8.11 OVERHEAD COILING COUNTER DOOR, SEE DETAIL 15 / A830
- 10.12 ROOM IDENTIFICATION SIGNAGE, TYP. SEE DETAIL 3 / A801
- 10.21 TOILET COMPARTMENT/JURNAL SCREEN, SEE DETAIL 8 / A800
- 10.91 CORNER GUARD, TYP. SEE DETAIL 6 / A860
- 11.17 PRINTER, OFOI
- 22.04 PLUMBING FIXTURE, SEE PLUMBING
- 26.03 WALL OUTLET, SEE ELECTRICAL, TYP.

IDENTIFICATION STAMP
 DIV. OF THE STATE ARCHITECT
 APP: 02-121813 INC.
 REVIEWED FOR
 SS FLS ACS
 DATE: 09/28/2023

MARK	DATE	DESCRIPTION	DSR BACKCHECK
	7/17/23	DSA BACKCHECK	



TETER, INC.
 FRESNO HEADQUARTERS
 VISUAL | BAKERSFIELD | MADERA | TULSA | LOS ORANGE
 ARCHITECTS ENGINEERS CONNECTED

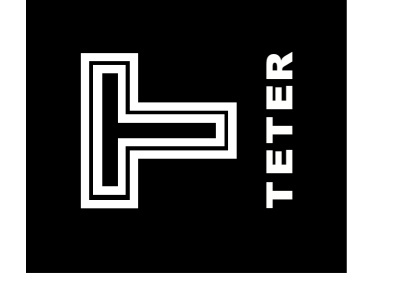

TOILET ACCESSORY SCHEDULE

MARK	DESCRIPTION	MFR.	MODEL NO.	REMARKS
A	MIRROR (18" X 30")	BOBRICK	B-165	SURFACE MTD.
B	TOILET TISSUE DISPENSER	BRADLEY	5241	SURFACE / PARTITION MTD.
C	MOP HOLDER	BOBRICK	B-223x24	SURFACE MTD.
D	ELECTRIC HAND DRYER	EXCEL DRYER INC.	XLERATOR	SURFACED MTD.
E	SOAP DISPENSER (O.F.C.I.)	IMPACT PRODUCTS	9326 FOAMEEZE	SURFACED MTD.
F	SANITARY NAPKIN DISPENSER	BOBRICK	B-2706 25	SURFACE MTD.
G	SANITARY NAPKIN DISPOSAL UNIT	BOBRICK	B-270	SURFACE MTD./PARTITION MTD.
H	TOILET SEAT COVER DISPENSER	BOBRICK	B-221	SURFACE MTD.
J	PAPER TOWEL DISPENSER (O.F.C.I.)	GP PRO UNIVERSAL PUSH PADDLE	54338A	SURFACE MTD.
K	GRAB BAR, SIDE	BOBRICK	B-6806 SERIES	48" LONG
L	GRAB BAR, REAR	BOBRICK	B-6806 SERIES	42" LONG
M	GRAB BAR, REAR	BOBRICK	B-6806 SERIES	30" LONG

GENERAL NOTES

- A. PROVIDE BLOCKING FOR ALL WALL MOUNTED ACCESSORIES AND EQUIPMENT, TYP. SEE 1 / A860
- B. FOR ACCESSIBLE FIXTURE AND ACCESSORY MOUNTING HEIGHTS AND CLEARANCES, SEE 12 / A800, 3 / A800, AND 13 / A800
- C. FOR TYPICAL CASEWORK ANCHORAGE SEE 2 / A861
- D. FOR GRAB BAR ANCHORAGE SEE 9 / A800 AND 10 / A800
- E. FOR MIRROR ANCHORAGE SEE 19 / A800 AND 20 / A800
- F. SEE INTERIOR FINISH SCHEDULE A800 AND A840 FOR ADDITIONAL INFORMATION.

KEY PLAN

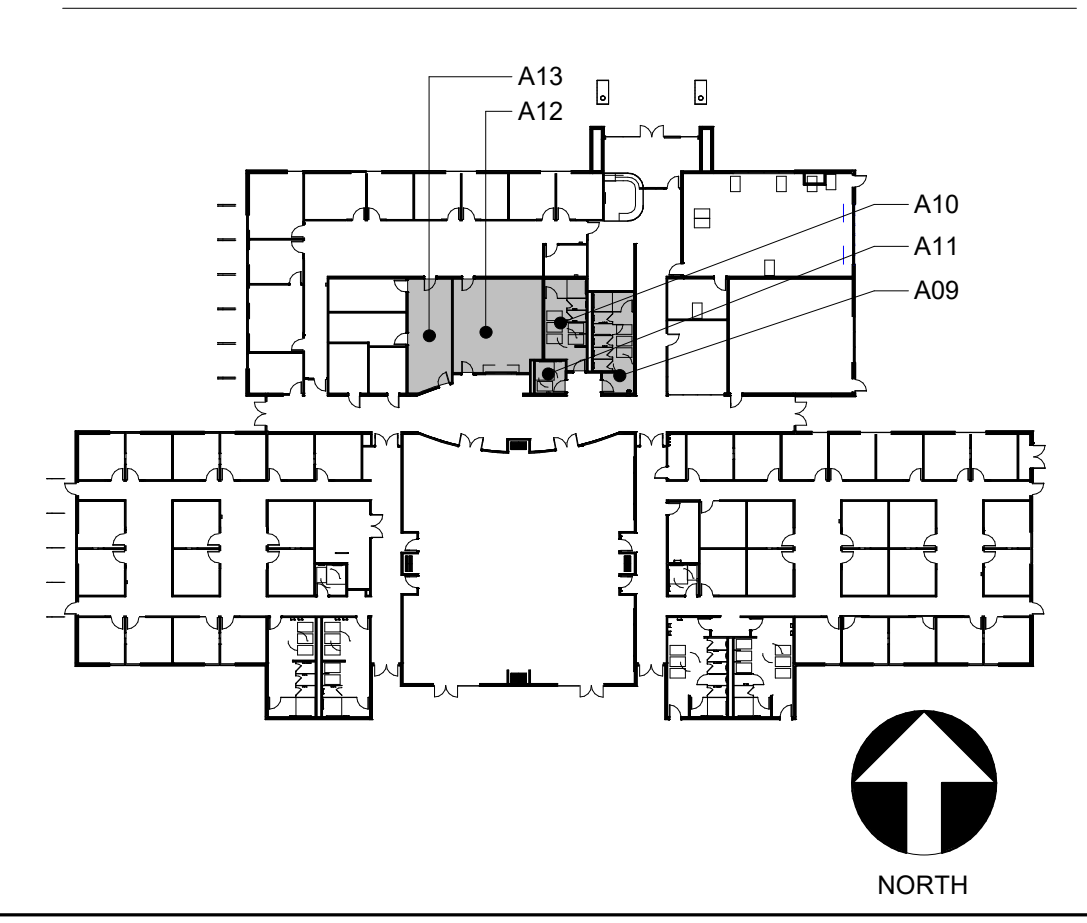

PLOT DATE: 9/13/2023 2:02:51 PM

ONLINE SCHOOL & SPECIAL EDUCATION
 ADMINISTRATION DISTRICT OFFICE EXPANSION
 CLOVIS UNIFIED SCHOOL DISTRICT
 CLOVIS, CA
 DRAWING TITLE
 INTERIOR ELEVATIONS - BLDG A - ONLINE SCHOOL

PROJECT NO.
 12242.00
 DRAWING
A914

\\netfiles1\Users\Elizabeth.Conti_TETRI\Documents\12242-A-DO_SITE_aliz.conteras.rvt

PLOT DATE: 9/13/2023 2:05:28 PM

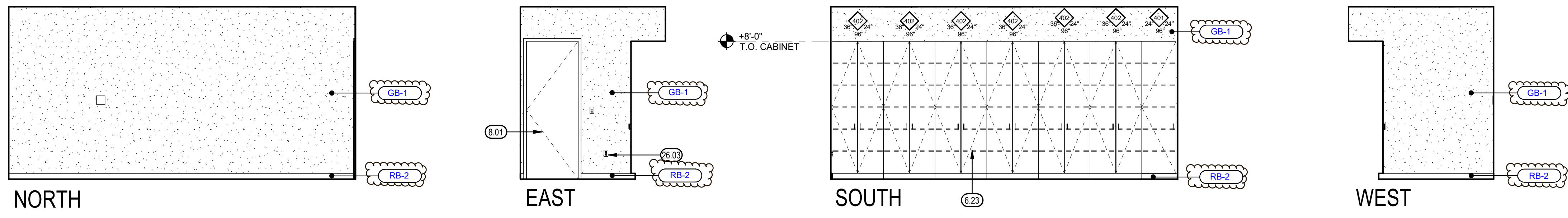

STORAGE (ELEMENTARY) - A14

1/4" = 1'-0" 7

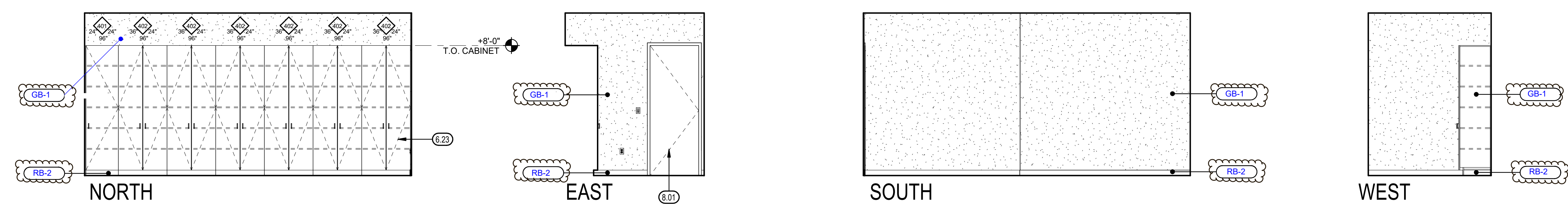

STORAGE (SECONDARY) - A15

1/4" = 1'-0" 8

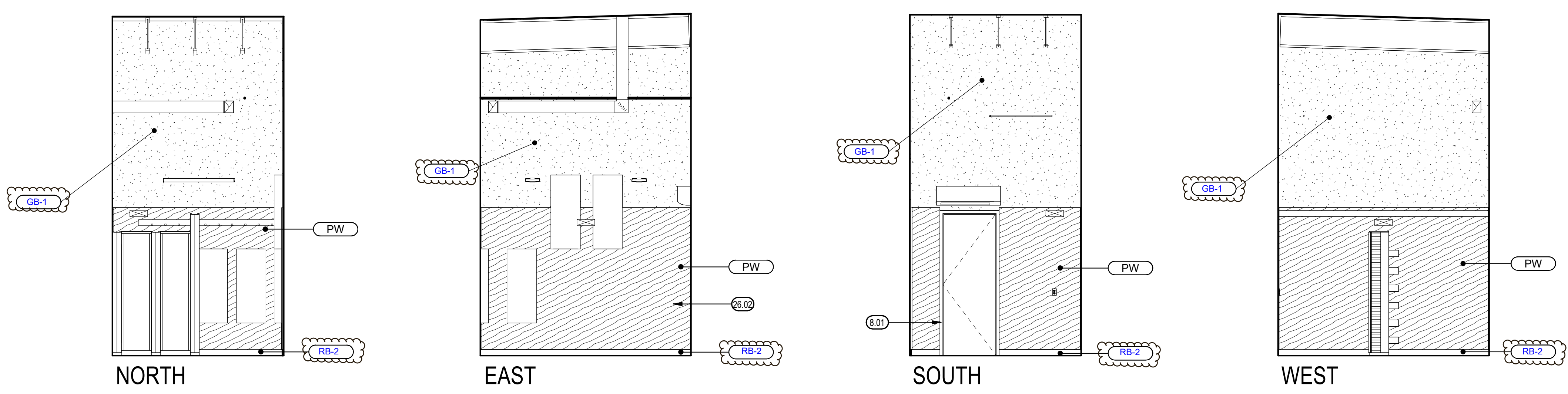

IT - A16

1/4" = 1'-0" 9



ELEC - A17

1/4" = 1'-0" 10

KEYNOTES

- 6.23 PLASTIC LAMINATE TALL STORAGE CABINET, SEE DETAIL 2 / A861
- 8.01 DOOR AND FRAME AS SCHEDULED
- 26.02 ELECTRICAL PANEL, SEE ELECTRICAL
- 26.03 WALL OUTLET, SEE ELECTRICAL, TYP.

IDENTIFICATION STAMP
 DIV. OF THE STATE ARCHITECT
 APP: 02-121813 INC.
 REVIEWED FOR
 SS FLS ACS
 DATE: 09/28/2023

For the purposes of this stamp, the architect reserves its copyright and other proprietary rights in these plans. This document, the instruments of professional service, is not to be used for any other project without the architect's written authorization.

MARK	DATE	DESCRIPTION
	7/17/23	DSA BACKCHECK



TETER, INC.
 PRESNO HEADQUARTERS
 VISALIA | BAKERSFIELD | MADERA | SAN LUIS OBISPO
 ARCHITECTS ENGINEERS CONNECTED

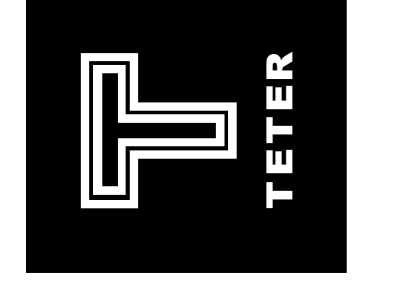

GENERAL NOTES

- A. PROVIDE BLOCKING FOR ALL WALL MOUNTED ACCESSORIES AND EQUIPMENT, TYP., SEE 1 / A860
- B. FOR ACCESSIBLE FIXTURE AND ACCESSORY MOUNTING HEIGHTS AND CLEARANCES, SEE 12 / A800, 3 / A800, AND 13 / A800
- C. FOR TYPICAL CASEWORK ANCHORAGE SEE 2 / A861
- D. FOR GRAB BAR ANCHORAGE SEE 9 / A800 AND 10 / A800
- E. FOR MIRROR ANCHORAGE SEE 19 / A800 AND 20 / A800
- F. SEE INTERIOR FINISH SCHEDULE A900 AND A940 FOR ADDITIONAL INFORMATION.

KEY PLAN

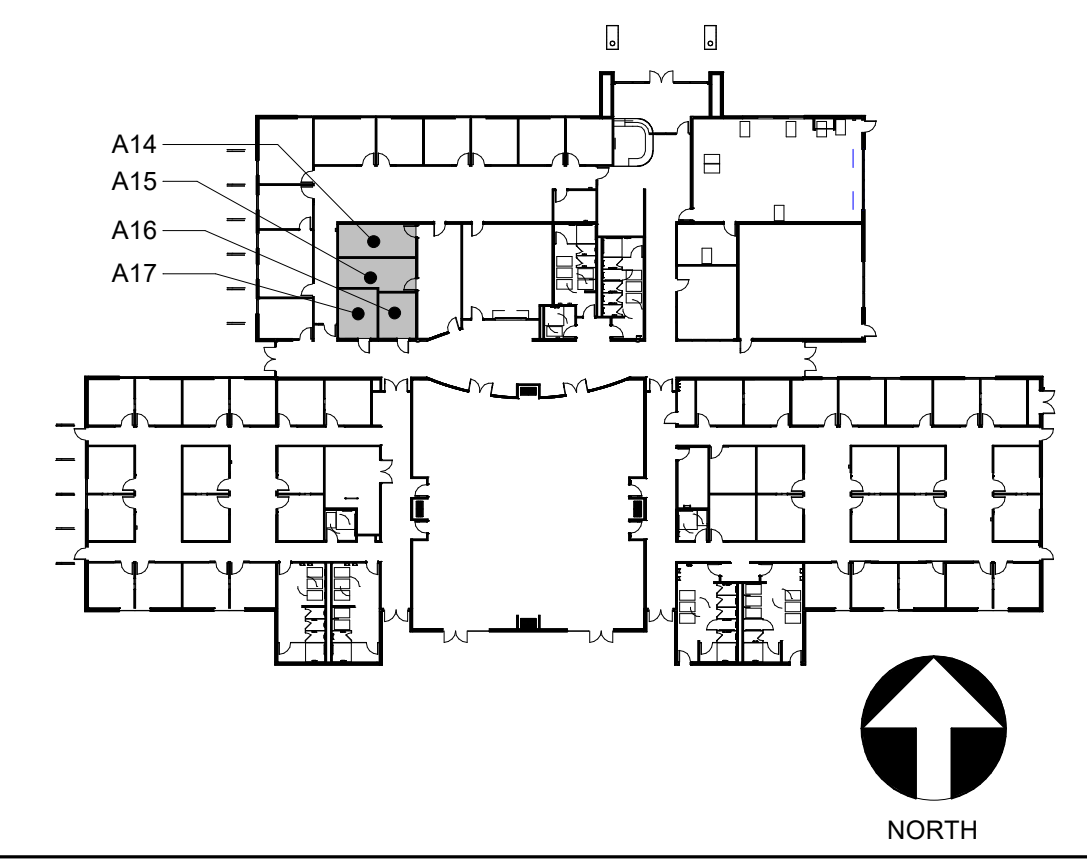

ONLINE SCHOOL & SPECIAL EDUCATION
 ADMINISTRATION DISTRICT OFFICE EXPANSION
 CLOVIS UNIFIED SCHOOL DISTRICT
 CLOVIS, CA
 DRAWING TITLE
 INTERIOR ELEVATIONS - BLDG A - ONLINE SCHOOL

PROJECT NO.
 12242.00
 DRAWING
A915

\\netfiles1\Users\Elizabeth.Conti_TETRI\Documents\12242-A-DO_SITE_elec.conterias.rvt

PLOT DATE: 9/13/2023 2:04:05 PM

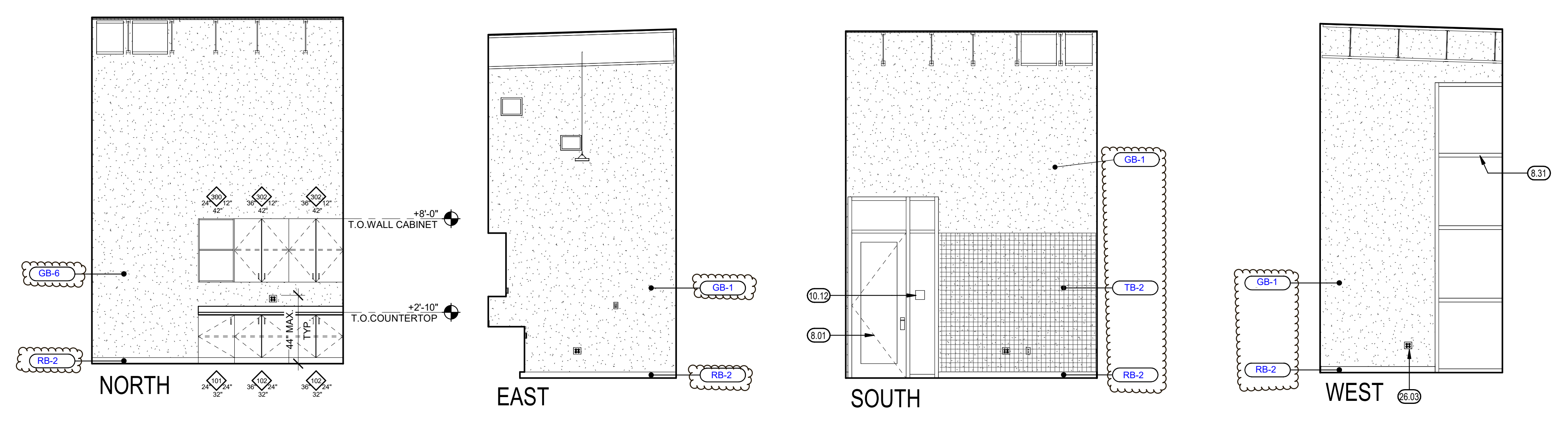

CUSTODIAL OFFICE - A18

1/4" = 1'-0" 10

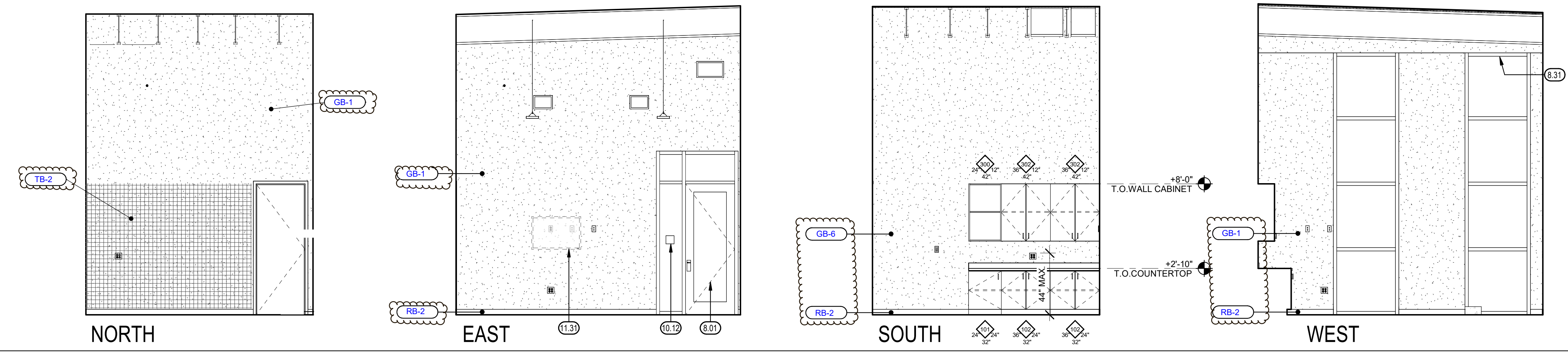

PRINCIPAL - A19

1/4" = 1'-0" 6

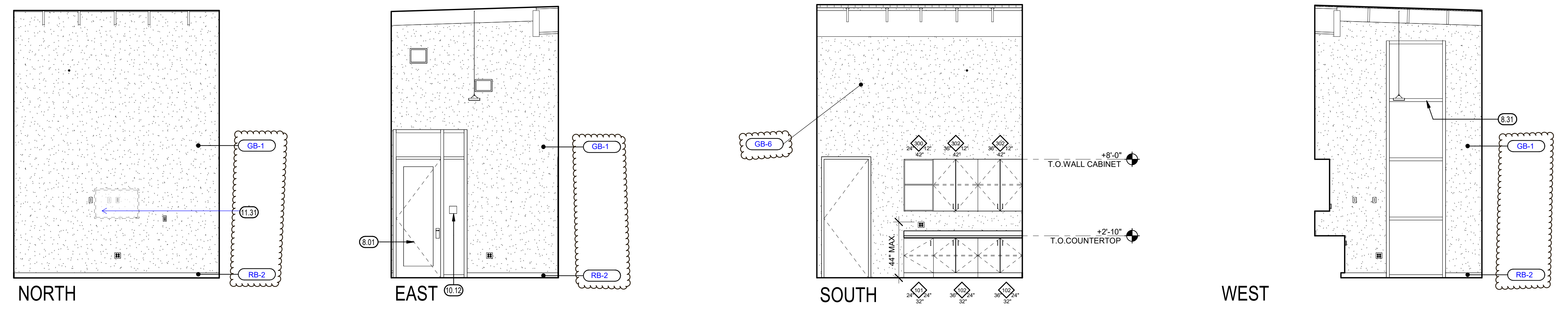

OFFICE MANAGER - A20

1/4" = 1'-0" 7

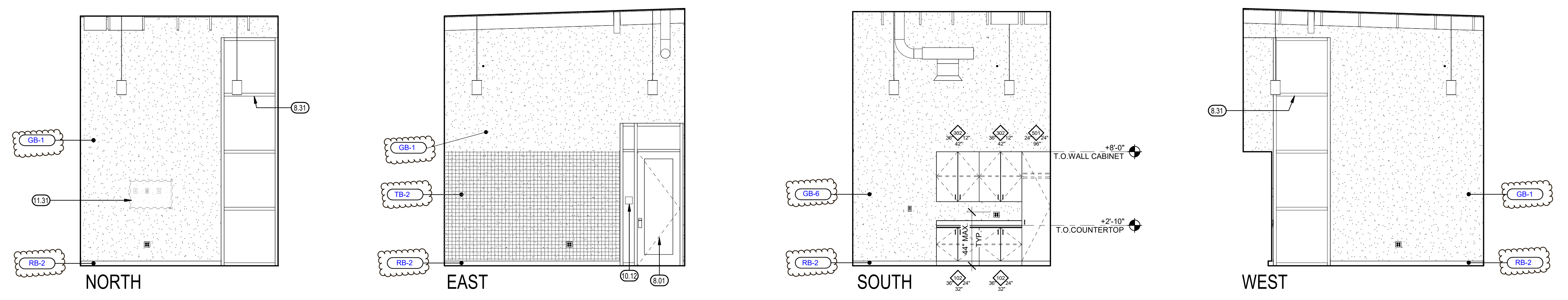

CONFERENCE - A21

1/4" = 1'-0" 8

KEYNOTES 00.00

8.01	DOOR AND FRAME AS SCHEDULED
8.31	WINDOW AND FRAME AS SCHEDULED
10.12	ROOM IDENTIFICATION SIGNAGE, TYP. SEE DETAIL 3 / A801
11.31	PROVIDE BACKING FOR OFCI MONITOR, SEE DETAILS 1/A860, 3/A860, 8/A860, & 12/A860
26.03	WALL OUTLET, SEE ELECTRICAL, TYP.

IDENTIFICATION STAMP
DIV. OF THE STATE ARCHITECT
APP: 02-121813 INC.
REVIEWED FOR
SS FLS ACS
DATE: 09/28/2023

Mark, Date, Description, DSA BACKCHECK

MARK	DATE	DESCRIPTION	DSA BACKCHECK
	7/17/23		

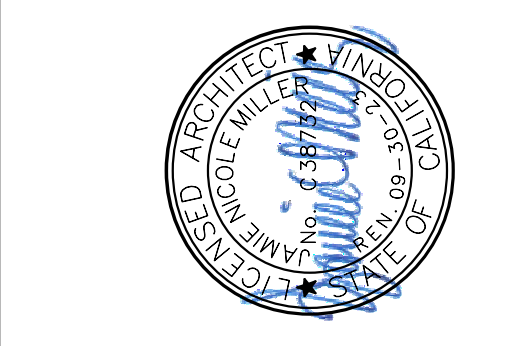

TETER, INC.
PRESNO HEADQUARTERS
VISALIA | BAKERSFIELD | MADERA | SAN LUIS OBISPO
ARCHITECTS ENGINEERS CONNECTED



- GENERAL NOTES**
- PROVIDE BLOCKING FOR ALL WALL MOUNTED ACCESSORIES AND EQUIPMENT, TYP. SEE 1 / A860
 - FOR ACCESSIBLE FIXTURE AND ACCESSORY MOUNTING HEIGHTS AND CLEARANCES, SEE 12 / A800, 3 / A800, AND 13 / A800
 - FOR TYPICAL CASEWORK ANCHORAGE SEE 2 / A861
 - FOR GRAB BAR ANCHORAGE SEE 9 / A800 AND 10 / A800
 - FOR MIRROR ANCHORAGE SEE 19 / A800 AND 20 / A800
 - SEE INTERIOR FINISH SCHEDULE A900 AND A940 FOR ADDITIONAL INFORMATION.

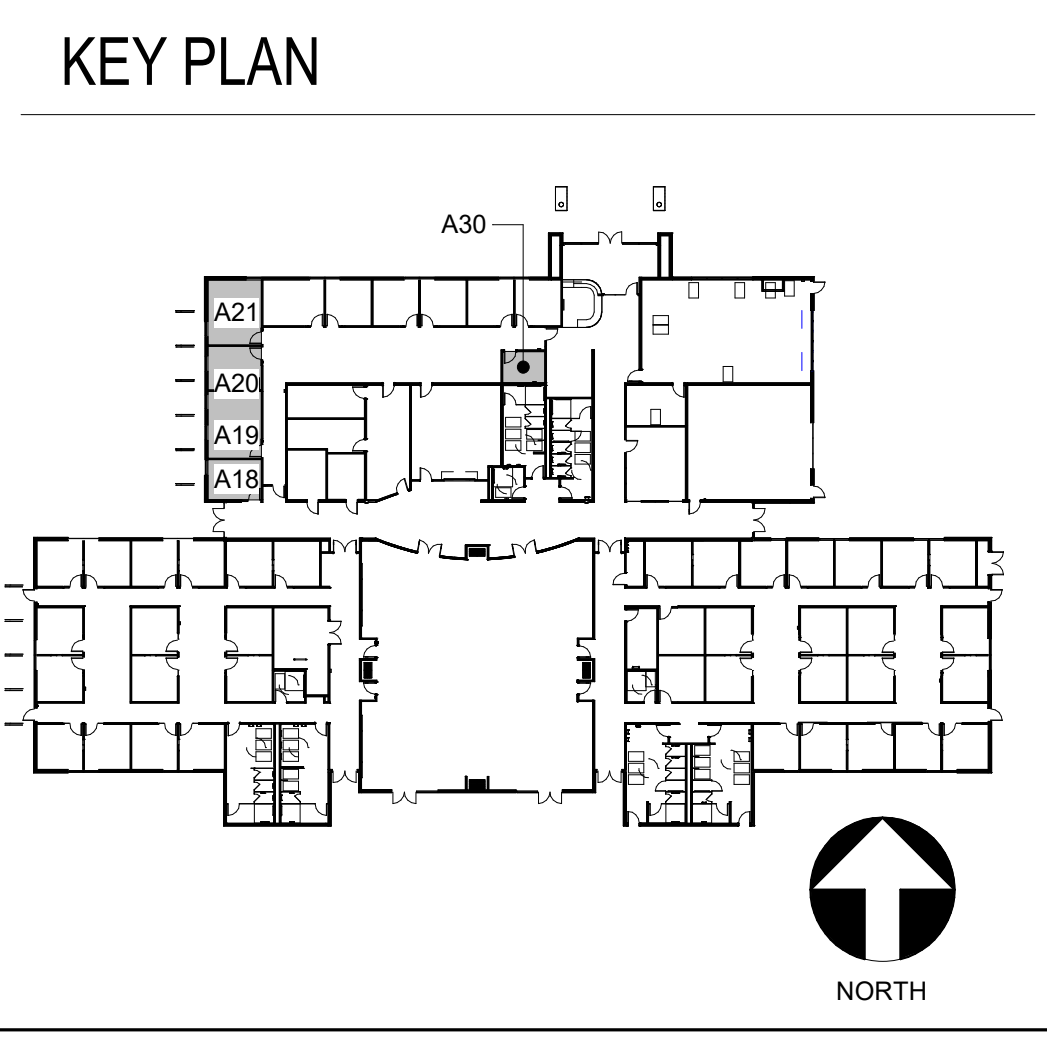

ONLINE SCHOOL & SPECIAL EDUCATION
ADMINISTRATION DISTRICT OFFICE EXPANSION
CLOVIS UNIFIED SCHOOL DISTRICT
CLOVIS, CA
DRAWING TITLE
INTERIOR ELEVATIONS - BLDG A - ONLINE SCHOOL

PROJECT NO.
12242.00
DRAWING
A916

\\netfiles1\Users\Elizabeth.Conti_TETRI\Documents\12242-A-DO_SITE_sitic.contreras.rvt

PLOT DATE: 9/13/2023 2:04:45 PM

KEYNOTES (0.00)

- 8.01 DOOR AND FRAME AS SCHEDULED
- 8.31 WINDOW AND FRAME AS SCHEDULED
- 10.12 ROOM IDENTIFICATION SIGNAGE, TYP. SEE DETAIL 3 / A801
- 11.31 PROVIDE BACKING FOR OF/O MONITOR, SEE DETAILS 11A860, 3/A860, 8/A860, & 12/A860
- 26.03 WALL OUTLET, SEE ELECTRICAL, TYP.

IDENTIFICATION STAMP
 DIV. OF THE STATE ARCHITECT
 APP: 02-121813 INC.
 REVIEWED FOR
 SS FLS ACS
 DATE: 09/28/2023

I hereby certify that the information contained in this document, the drawings, and the specifications incorporated herein, are the work of professional engineers, architects, or other qualified persons, and that I am duly licensed and qualified to perform the services herein.

MARK	DATE	DESCRIPTION
	7/17/23	DSA BACKCHECK



TETER, INC.
 FRESNO HEADQUARTERS
 VISALIA | BAKERSFIELD | MADERA | SAN LUIS OBISPO
 ARCHITECTS ENGINEERS CONNECTED

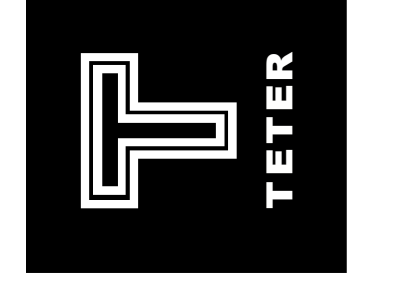

**ONLINE SCHOOL & SPECIAL EDUCATION
 ADMINISTRATION DISTRICT OFFICE EXPANSION
 CLOVIS UNIFIED SCHOOL DISTRICT**
 CLOVIS, CA
 DRAWING TITLE
 INTERIOR ELEVATIONS - BLDG A - ONLINE SCHOOL

PROJECT NO.
 12242.00
 DRAWING
A917

GIS - A22

1/4" = 1'-0" 7

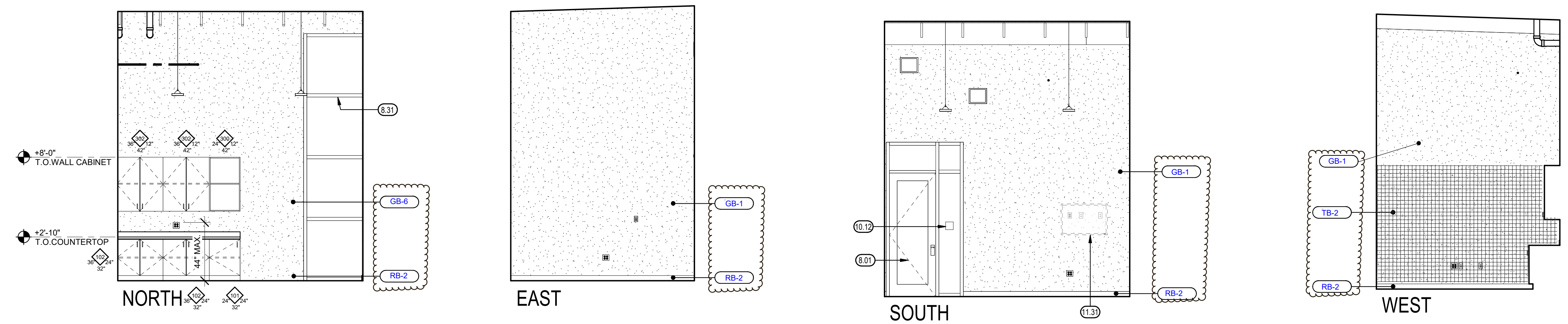

LACTATION - A30

1/4" = 1'-0" 8

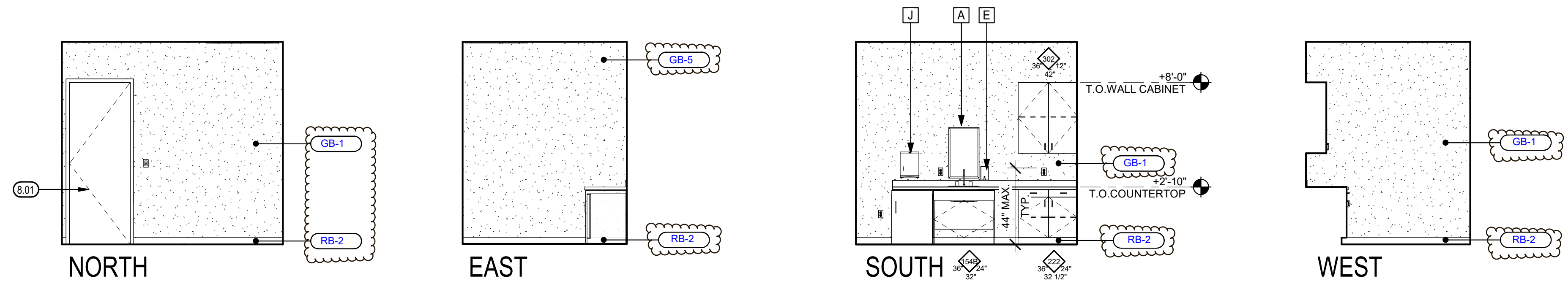

TOILET ACCESSORY SCHEDULE

MARK	DESCRIPTION	MFR.	MODEL NO.	REMARKS
A	MIRROR (18" X 30")	BOBRICK	B-165	SURFACE MTD.
B	TOILET TISSUE DISPENSER	BRADLEY	5241	SURFACE / PARTITION MTD.
C	MOP HOLDER	BOBRICK	B-223x24	SURFACE MTD.
D	ELECTRIC HAND DRYER	EXCEL DRYER INC.	XLERATOR	SURFACED MTD.
E	SOAP DISPENSER (O.F.C.I.)	IMPACT PRODUCTS	9326 FOAMEEZE	SURFACED MTD.
F	SANITARY NAPKIN DISPENSER	BOBRICK	B-2706 25	SURFACE MTD.
G	SANITARY NAPKIN DISPOSAL UNIT	BOBRICK	B-270	SURFACE MTD. / PARTITION MTD.
H	TOILET SEAT COVER DISPENSER	BOBRICK	B-221	SURFACE MTD.
J	PAPER TOWEL DISPENSER (O.F.C.I.)	GP PRO UNIVERSAL PUSH PADDLE	54338A	SURFACE MTD.
K	GRAB BAR, SIDE	BOBRICK	B-6806 SERIES	48" LONG
L	GRAB BAR, REAR	BOBRICK	B-6806 SERIES	42" LONG
M	GRAB BAR, REAR	BOBRICK	B-6806 SERIES	30" LONG

TYPICAL OFFICE ARRANGEMENT 1

1/4" = 1'-0" 9

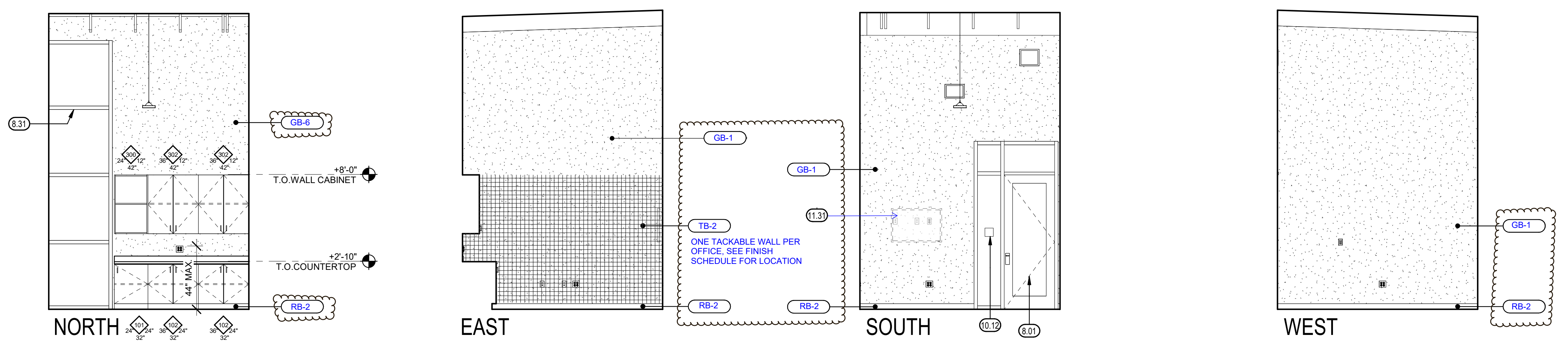

THESE ELEVATIONS APPLY TO:
 A23 A61
 A25 A69
 A27 A86
 A37 A88
 A39
 A59

MIRRORED ROOM CONFIGURATIONS APPLY TO:
 A24 A62
 A26 A68
 A36 A70
 A38 A87
 A60

CASEWORK DIMENSIONS TO BE VERIFIED ON SITE PRIOR TO FABRICATION

TYPICAL OFFICE ARRANGEMENT 2

1/4" = 1'-0" 10

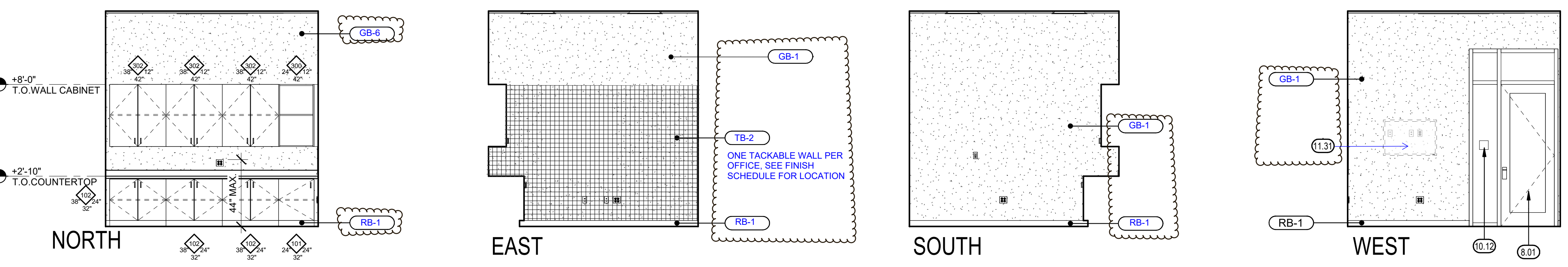

THESE ELEVATIONS APPLY TO:
 A33 A50 A77
 A34 A51 A79
 A42 A52 A82
 A43 A53 A83
 A45 A72
 A46 A73

CASEWORK DIMENSIONS TO BE VERIFIED ON SITE PRIOR TO FABRICATION

GENERAL NOTES

- A. PROVIDE BLOCKING FOR ALL WALL MOUNTED ACCESSORIES AND EQUIPMENT, TYP., SEE 1 / A860
- B. FOR ACCESSIBLE FIXTURE AND ACCESSORY MOUNTING HEIGHTS AND CLEARANCES, SEE 12 / A800, 3 / A800, AND 13 / A800
- C. FOR TYPICAL CASEWORK ANCHORAGE SEE 2 / A861
- D. FOR GRAB BAR ANCHORAGE SEE 9 / A800 AND 10 / A800
- E. FOR MIRROR ANCHORAGE SEE 19 / A800 AND 20 / A800
- F. SEE INTERIOR FINISH SCHEDULE A900 AND A940 FOR ADDITIONAL INFORMATION.

KEY PLAN

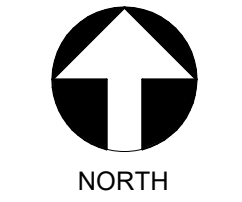
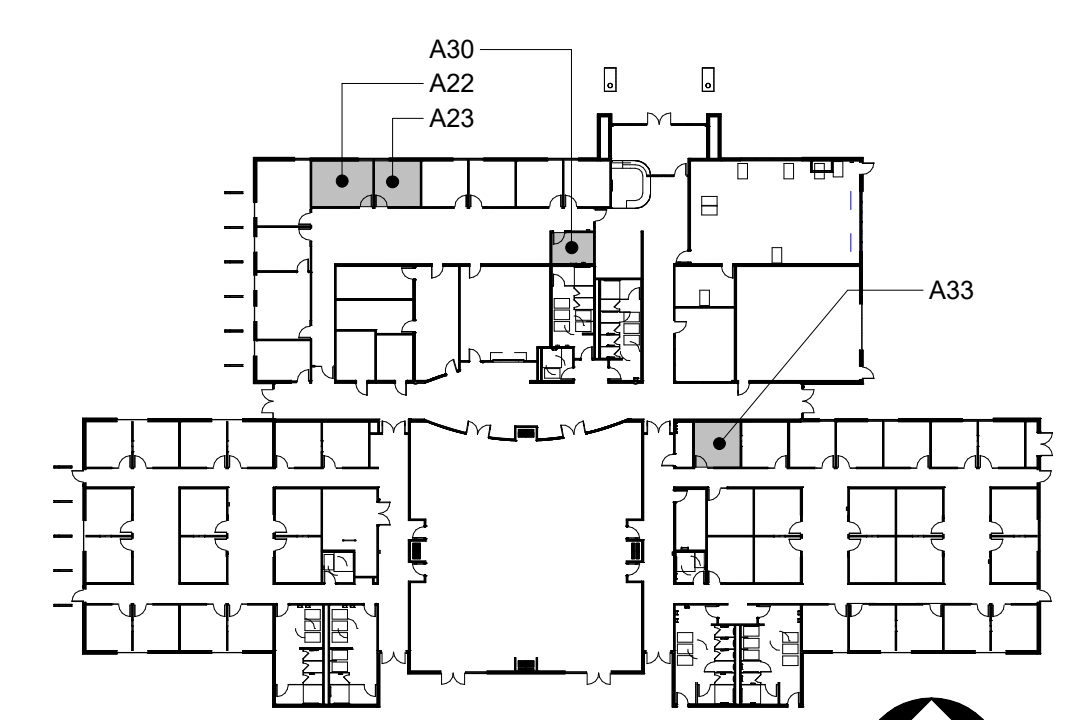

\\netfiles1\Users\Elizabeth.Conti_TETRI\Documents\12242-A-DO_SITE_elec.contriers.rvt

IDENTIFICATION STAMP
DIV. OF THE STATE ARCHITECT
APP: 02-121813 INC.
REVIEWED FOR:
SS FLS ACS
DATE: 09/28/2023

I hereby certify that the information contained in this document, the plans, specifications, and contract documents incorporated herein, are an original and true copy of the work of the architect and are not to be used for any other project without the prior written authorization of the architect.

MARK	DATE	DESCRIPTION
	7/17/23	DSA BACKCHECK

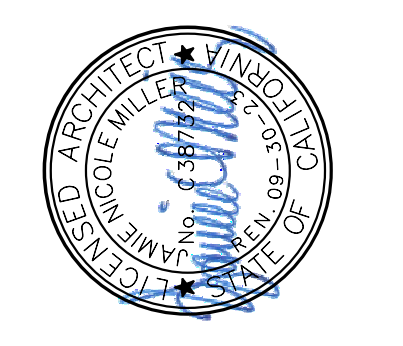

TETER, INC.
PRESNO HEADQUARTERS
VISALIA | BAKERSFIELD | MADERA | SAN LUIS OBISPO
ARCHITECTS ENGINEERS CONNECTED

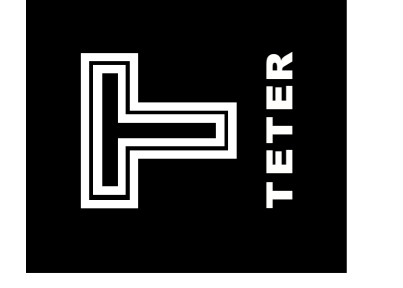

ONLINE SCHOOL & SPECIAL EDUCATION
ADMINISTRATION DISTRICT OFFICE EXPANSION
CLOVIS UNIFIED SCHOOL DISTRICT
CLOVIS, CA
DRAWING TITLE

PROJECT NO.
12242.00
DRAWING
A918

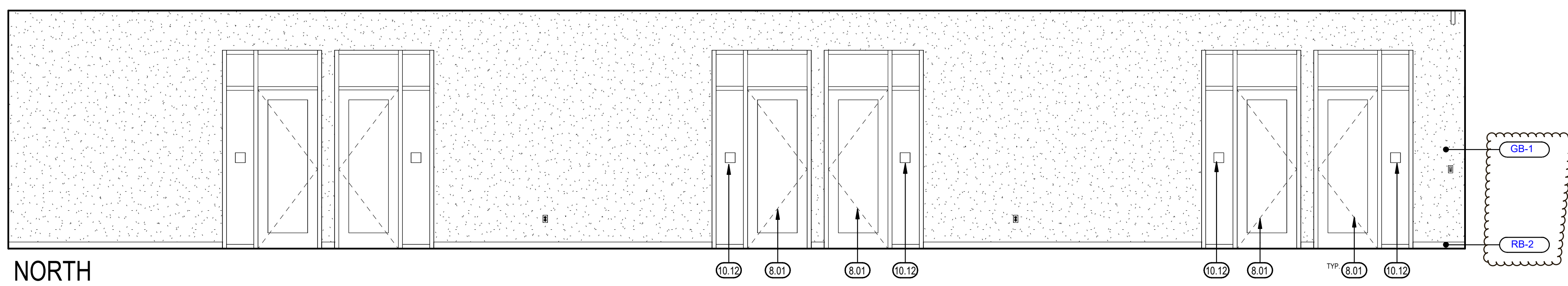

NORTH

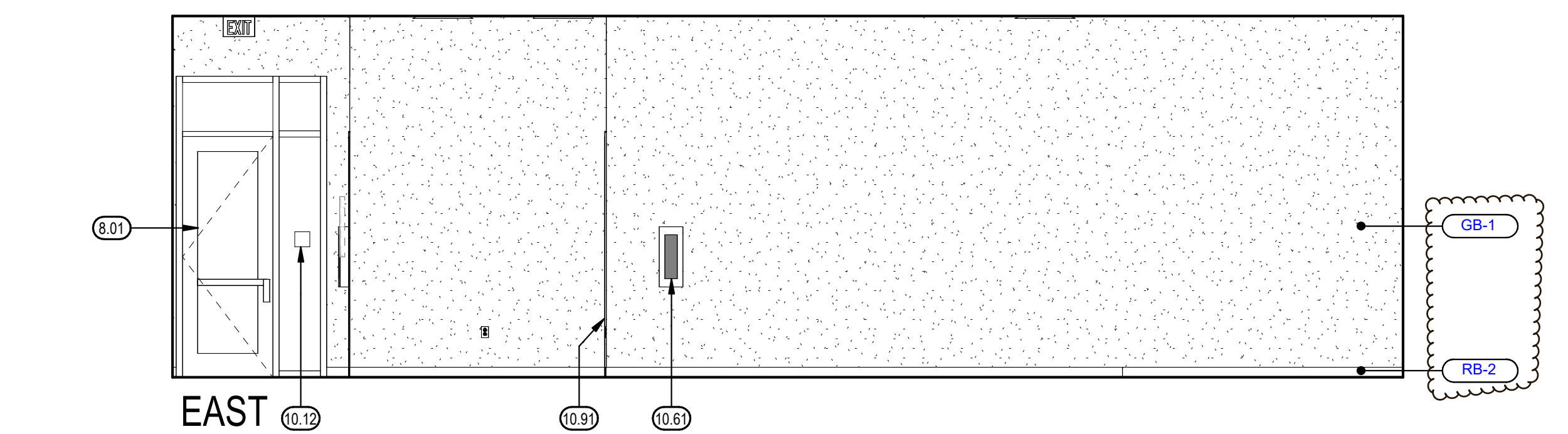

EAST

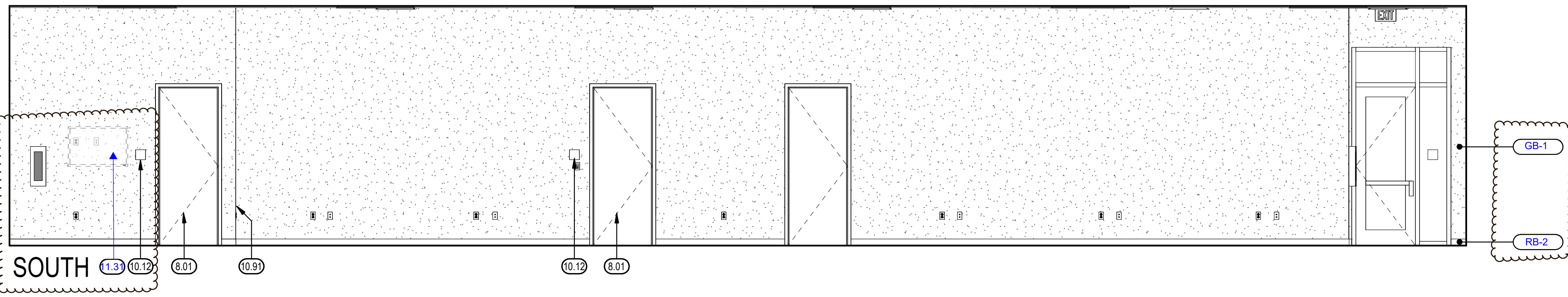

SOUTH

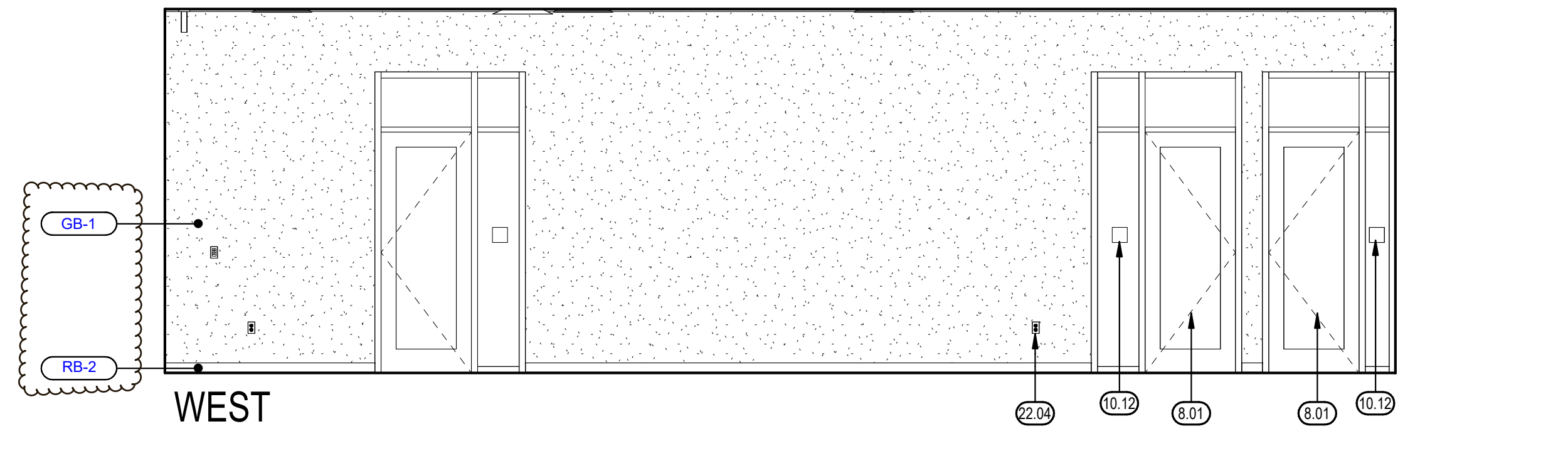

WEST

ADMINISTRATION CORRIDOR - A28

1/4" = 1'-0" 2

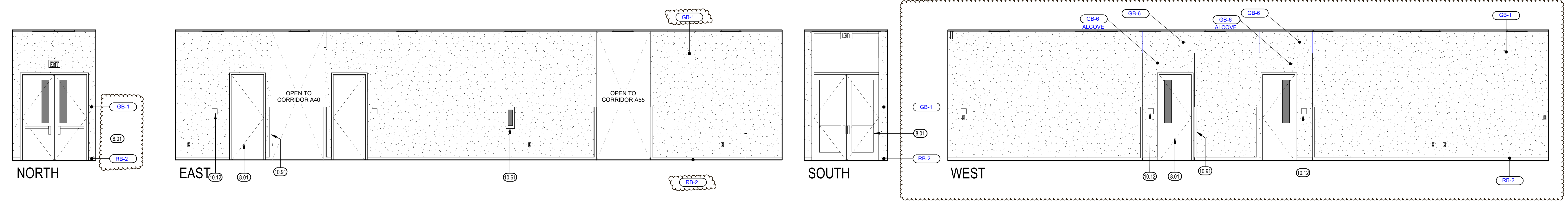

CORRIDOR - A31

1/4" = 1'-0" 3

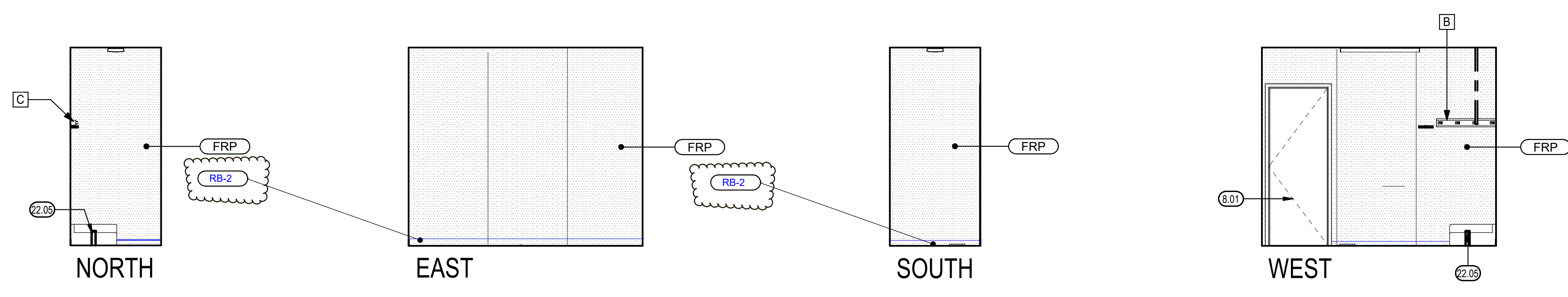

CUSTODIAL - A32

1/4" = 1'-0" 4

KEYNOTES

- 8.01 DOOR AND FRAME AS SCHEDULED
- 10.12 ROOM IDENTIFICATION SIGNAGE, TYP. SEE DETAIL 3 / A801
- 10.61 FIRE EXTINGUISHER CABINET AND FIRE EXTINGUISHER
- 10.91 CORNER GUARD, TYP. SEE DETAIL 6 / A860
- 22.04 PLUMBING FIXTURE, SEE PLUMBING
- 22.05 MOP SINK, SEE PLUMBING
- 26.03 WALL OUTLET, SEE ELECTRICAL, TYP.
- 11.31 PROVIDE BACKING FOR OFC MONITOR, SEE DETAILS 1/A860, 3/A860, 8/A860, & 12/A860

TOILET ACCESSORY SCHEDULE

MARK	DESCRIPTION	MFR.	MODEL NO.	REMARKS
A	MIRROR (18" X 30")	BOBRICK	B-165	SURFACE MTD.
B	TOILET TISSUE DISPENSER	BRADLEY	5241	SURFACE / PARTITION MTD.
C	MOP HOLDER	BOBRICK	B-223x24	SURFACE MTD.
D	ELECTRIC HAND DRYER	EXCEL DRYER INC.	XLERATOR	SURFACED MTD.
E	SOAP DISPENSER (O.F.C.I.)	IMPACT PRODUCTS	9326 FOAMEEZE	SURFACED MTD.
F	SANITARY NAPKIN DISPENSER	BOBRICK	B-2706 25	SURFACE MTD.
G	SANITARY NAPKIN DISPOSAL UNIT	BOBRICK	B-270	SURFACE MTD./PARTITION MTD.
H	TOILET SEAT COVER DISPENSER	BOBRICK	B-221	SURFACE MTD.
J	PAPER TOWEL DISPENSER (O.F.C.I.)	GP PRO UNIVERSAL	54338A	SURFACE MTD.
K	GRAB BAR, SIDE	BOBRICK	B-6806 SERIES	48" LONG
L	GRAB BAR, REAR	BOBRICK	B-6806 SERIES	42" LONG
M	GRAB BAR, REAR	BOBRICK	B-6806 SERIES	30" LONG

GENERAL NOTES

- A. PROVIDE BLOCKING FOR ALL WALL MOUNTED ACCESSORIES AND EQUIPMENT, TYP. SEE 1 / A860
- B. FOR ACCESSIBLE FIXTURE AND ACCESSORY MOUNTING HEIGHTS AND CLEARANCES, SEE 12 / A800, 3 / A800, AND 13 / A800
- C. FOR TYPICAL CASEWORK ANCHORAGE SEE 2 / A861
- D. FOR GRAB BAR ANCHORAGE SEE 9 / A800 AND 10 / A800
- E. FOR MIRROR ANCHORAGE SEE 19 / A800 AND 20 / A800
- F. SEE INTERIOR FINISH SCHEDULE A900 AND A940 FOR ADDITIONAL INFORMATION.

KEY PLAN

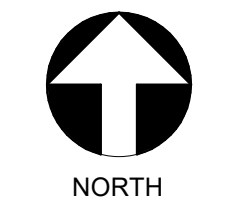
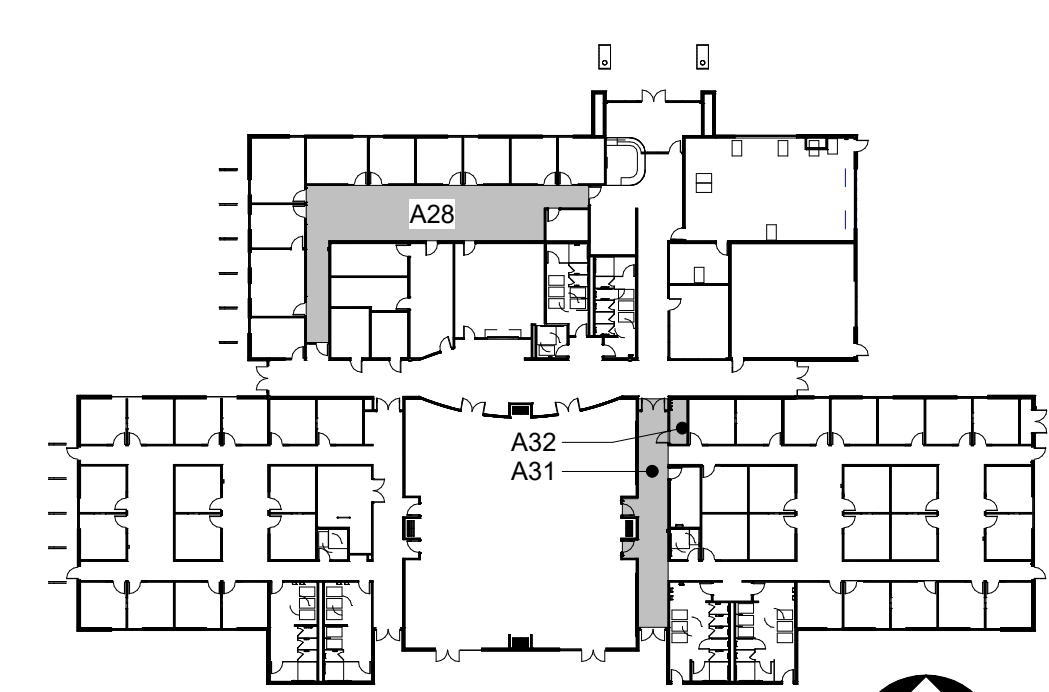

PLOT DATE: 9/13/2023 2:05:17 PM

\\net-files\1\Users\Elizbeth.Conti_TETRI\Documents\12242-A40_SITE_elevations.rvt

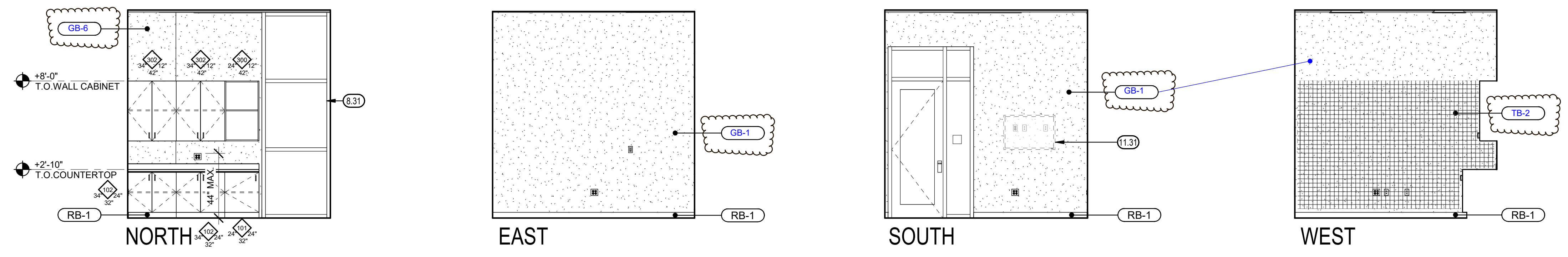

THESE ELEVATIONS APPLY TO:
 A35
 A89

MIRRORED ROOM CONFIGURATIONS APPLY TO:
 A58
 A71

CASEWORK DIMENSIONS TO BE VERIFIED ON SITE PRIOR TO FABRICATION

- KEYNOTES** (0,0)
- 8.01 DOOR AND FRAME AS SCHEDULED
 - 8.31 WINDOW AND FRAME AS SCHEDULED
 - 10.12 ROOM IDENTIFICATION SIGNAGE, TYP. SEE DETAIL 3 / A801
 - 11.31 PROVIDE BACKING FOR QFOI MONITOR, SEE DETAILS 1/A860, 3/A860, 8/A860, & 12/A860
 - 26.02 ELECTRICAL PANEL, SEE ELECTRICAL

IDENTIFICATION STAMP
 DIV. OF THE STATE ARCHITECT
 APP: 02-121813 INC.
 REVIEWED FOR
 SS FS ACS
 DATE: 09/28/2023

MARK	DATE	DESCRIPTION
	7/17/23	DSA BACKCHECK



TYPICAL OFFICE ARRANGEMENT 3

1/4" = 1'-0" 6

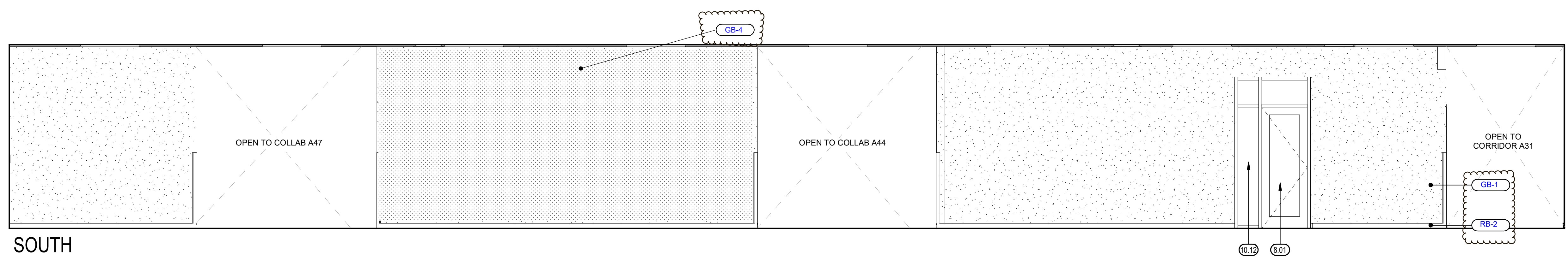
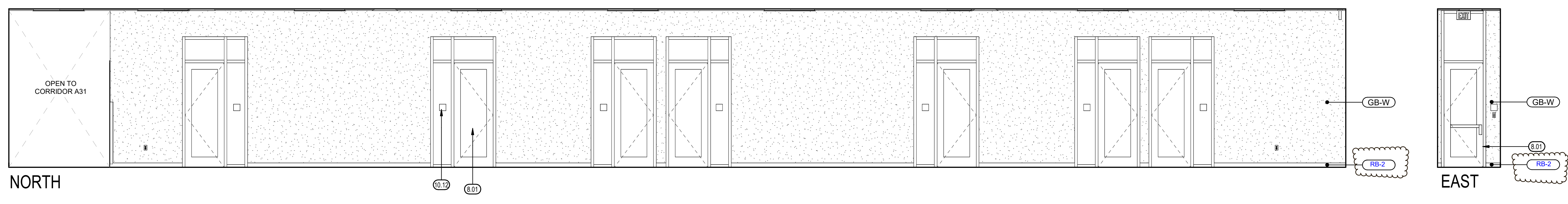

CORRIDOR 5 - A40

1/4" = 1'-0" 8

- GENERAL NOTES**
- A. PROVIDE BLOCKING FOR ALL WALL MOUNTED ACCESSORIES AND EQUIPMENT, TYP. SEE 1 / A860
 - B. FOR ACCESSIBLE FIXTURE AND ACCESSORY MOUNTING HEIGHTS AND CLEARANCES, SEE 12 / A800, 3 / A800, AND 13 / A800
 - C. FOR TYPICAL CASEWORK ANCHORAGE SEE 2 / A861
 - D. FOR GRAB BAR ANCHORAGE SEE 9 / A800 AND 10 / A800
 - E. FOR MIRROR ANCHORAGE SEE 19 / A800 AND 20 / A800
 - F. SEE INTERIOR FINISH SCHEDULE A900 AND A940 FOR ADDITIONAL INFORMATION.

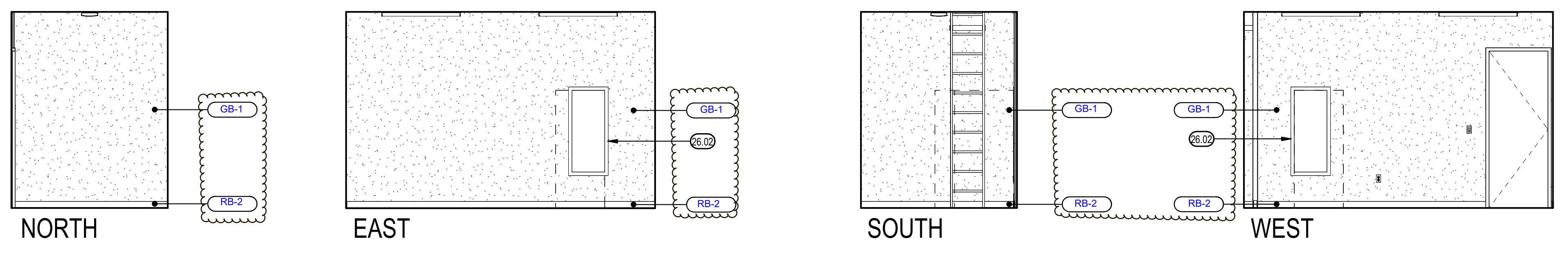

STORAGE - A41

1/4" = 1'-0" 9

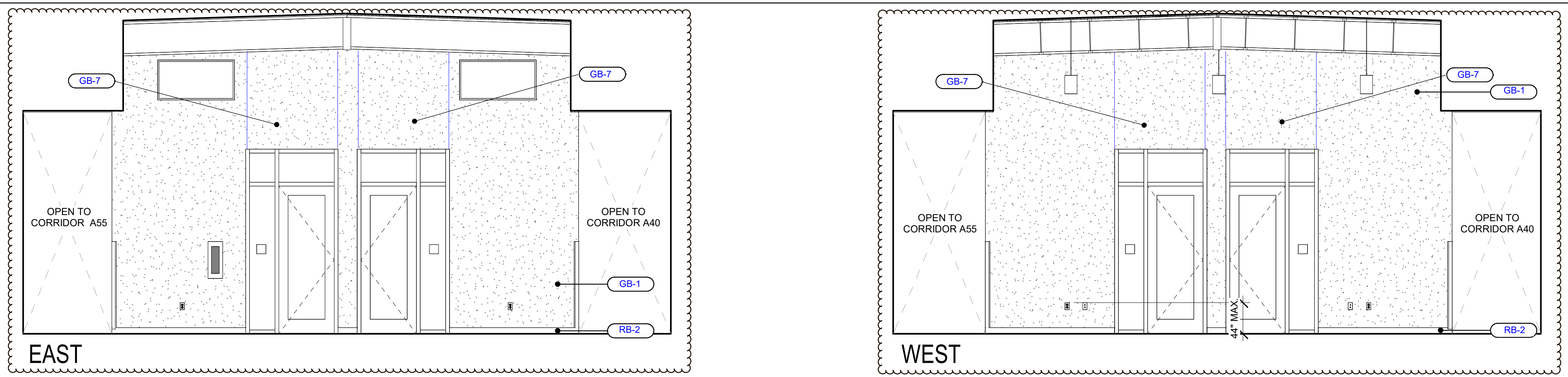

COLLABORATION SPACE - A44

1/4" = 1'-0" 10

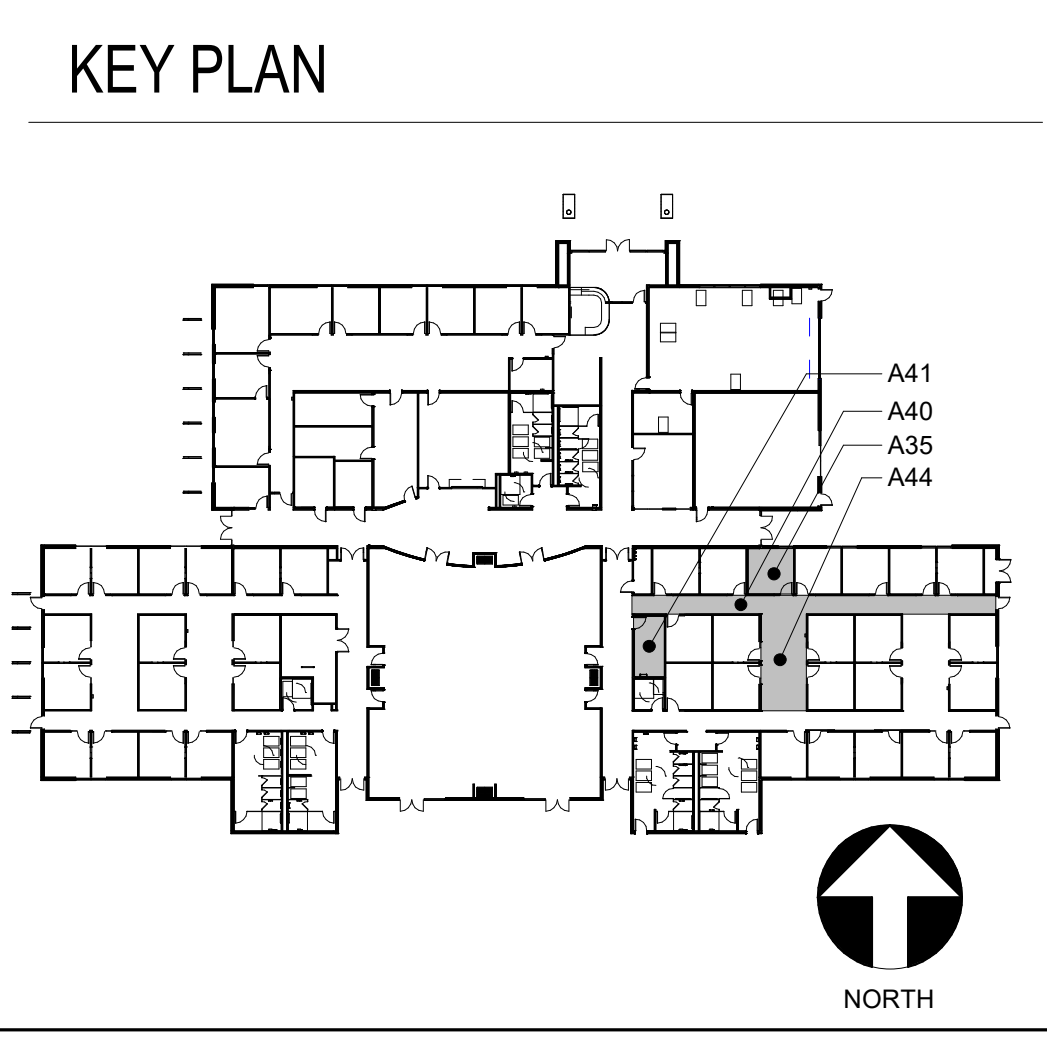

TETER, INC.
 PRESNO HEADQUARTERS
 VISALIA | BAKERSFIELD | MADERA | SAN LUIS OBISPO
 ARCHITECTS ENGINEERS CONNECTED

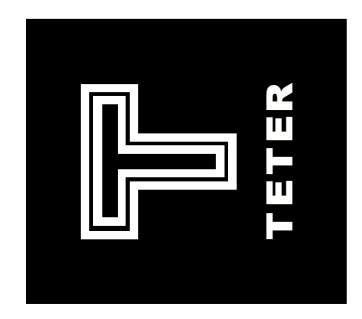

ONLINE SCHOOL & SPECIAL EDUCATION
 ADMINISTRATION DISTRICT OFFICE EXPANSION
 CLOVIS UNIFIED SCHOOL DISTRICT
 CLOVIS, CA
 DRAWING TITLE
 INTERIOR ELEVATIONS - BLDG A - ONLINE SCHOOL

PROJECT NO.
 12242.00
 DRAWING
A919

PLOT DATE: 9/13/2023 2:05:50 PM

\\netfiles1\Users\Elizabeth.Conti_TETRI\Documents\12242-A-DO_SITE_sitic.com\interiors.rvt

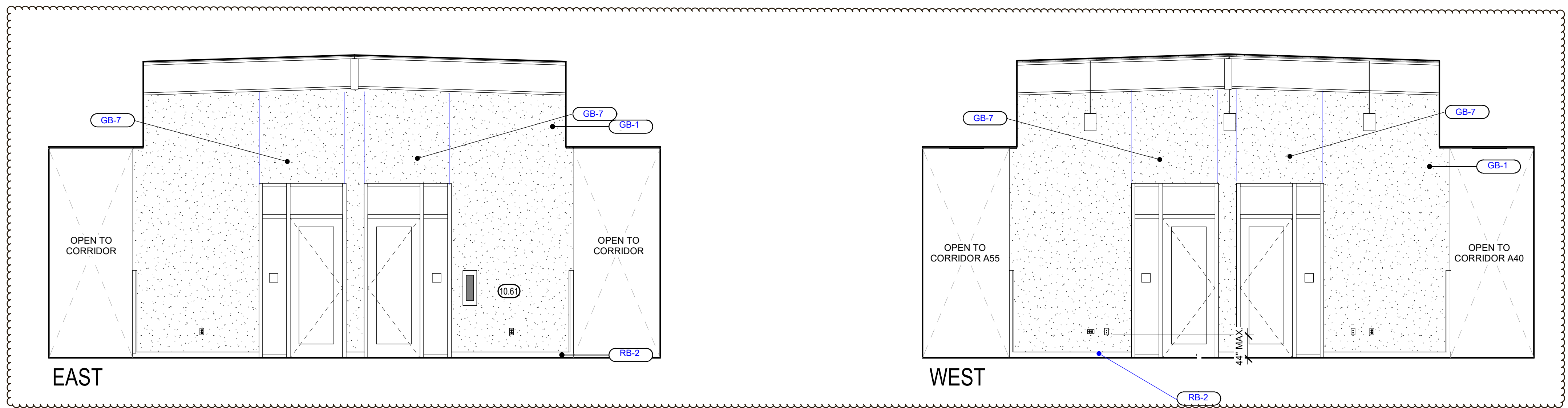

COLLABORATION SPACE - A47

1/4" = 1'-0" 6

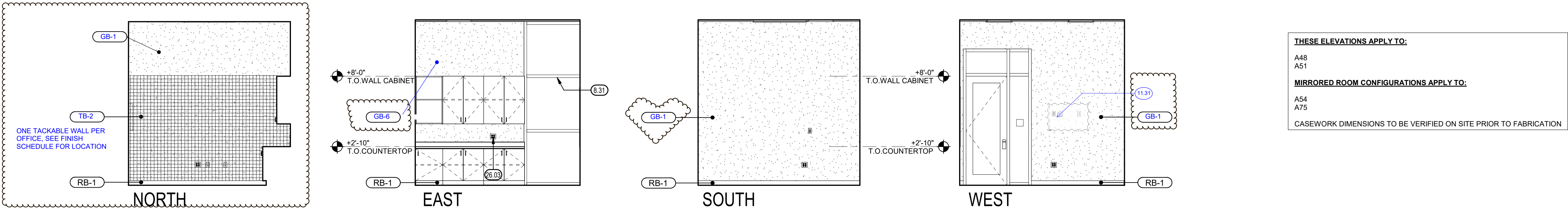

TYPICAL OFFICE ARRANGEMENT 4

1/4" = 1'-0" 7

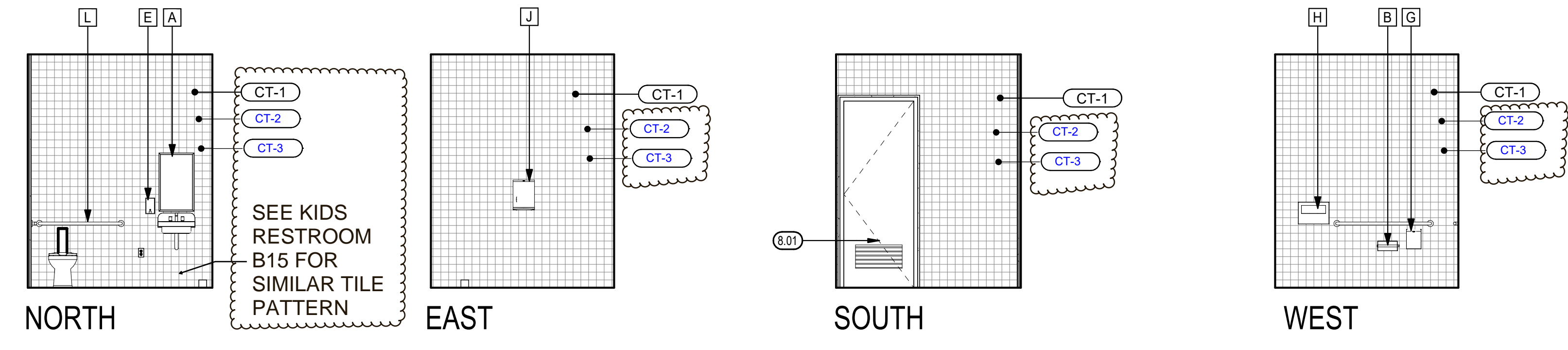

TOILET ACCESSORY SCHEDULE

MARK	DESCRIPTION	MFR.	MODEL NO.	REMARKS
A	MIRROR (18" X 30")	BOBRICK	B-165	SURFACE MTD.
B	TOILET TISSUE DISPENSER	BRADLEY	5241	SURFACE / PARTITION MTD.
C	MOP HOLDER	BOBRICK	B-223x24	SURFACE MTD.
D	ELECTRIC HAND DRYER	EXCEL DRYER INC.	XLERATOR	SURFACED MTD.
E	SOAP DISPENSER (O.F.C.I.)	IMPACT PRODUCTS	9326 FOAMEEZE	SURFACED MTD.
F	SANITARY NAPKIN DISPENSER	BOBRICK	B-2706 25	SURFACE MTD.
G	SANITARY NAPKIN DISPOSAL UNIT	BOBRICK	B-270	SURFACE MTD./PARTITION MTD.
H	TOILET SEAT COVER DISPENSER	BOBRICK	B-221	SURFACE MTD.
J	PAPER TOWEL DISPENSER (O.F.C.I.)	GP PRO UNIVERSAL PUSH PADDLE	54338A	SURFACE MTD.
K	GRAB BAR, SIDE	BOBRICK	B-6806 SERIES	48" LONG
L	GRAB BAR, REAR	BOBRICK	B-6806 SERIES	42" LONG
M	GRAB BAR, REAR	BOBRICK	B-6806 SERIES	30" LONG

UNISEX - A49

1/4" = 1'-0" 8

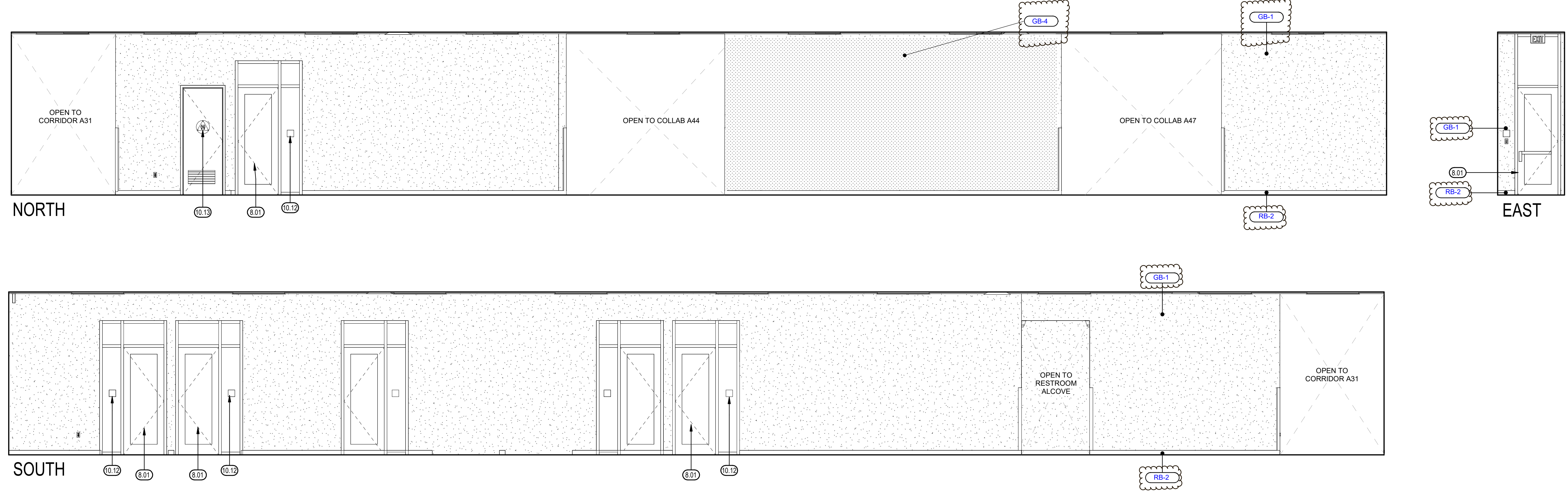

CORRIDOR 6 - A55

1/4" = 1'-0" 10

KEYNOTES

- 8.01 DOOR AND FRAME AS SCHEDULED
- 8.31 WINDOW AND FRAME AS SCHEDULED
- 10.12 ROOM IDENTIFICATION SIGNAGE, TYP. SEE DETAIL 3 / A801
- 10.13 TOILET ROOM GEOMETRIC SYMBOLS, SEE DETAIL 5 / A801
- 10.61 FIRE EXTINGUISHER CABINET AND FIRE EXTINGUISHER
- 22.04 PLUMBING FIXTURE, SEE PLUMBING
- 26.03 WALL OUTLET, SEE ELECTRICAL, TYP.
- 11.31 PROVIDE BACKING FOR OFST MONITOR, SEE DETAILS 11A860, 3A860, 8A860, & 12A860

IDENTIFICATION STAMP
DIV. OF THE STATE ARCHITECT
APP: 02-121813 INC.
REVIEWED FOR:
SS FLS ACS
DATE: 09/28/2023

MARK	DATE	DESCRIPTION
	7/17/23	DSA BACKCHECK

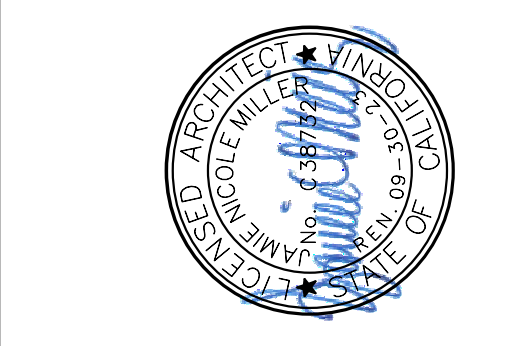

TETER, INC.
FRESNO HEADQUARTERS
VISALIA | BAKERSFIELD | MADERA | SAN LUIS OBISPO
ARCHITECTS ENGINEERS CONNECTED



GENERAL NOTES

- A. PROVIDE BLOCKING FOR ALL WALL MOUNTED ACCESSORIES AND EQUIPMENT, TYP., SEE 1 / A860
- B. FOR ACCESSIBLE FIXTURE AND ACCESSORY MOUNTING HEIGHTS AND CLEARANCES, SEE 12 / A800, 3 / A800, AND 13 / A800
- C. FOR TYPICAL CASEWORK ANCHORAGE SEE 2 / A861
- D. FOR GRAB BAR ANCHORAGE SEE 9 / A800 AND 10 / A800
- E. FOR MIRROR ANCHORAGE SEE 19 / A800 AND 20 / A800
- F. SEE INTERIOR FINISH SCHEDULE A900 AND A940 FOR ADDITIONAL INFORMATION.

KEY PLAN

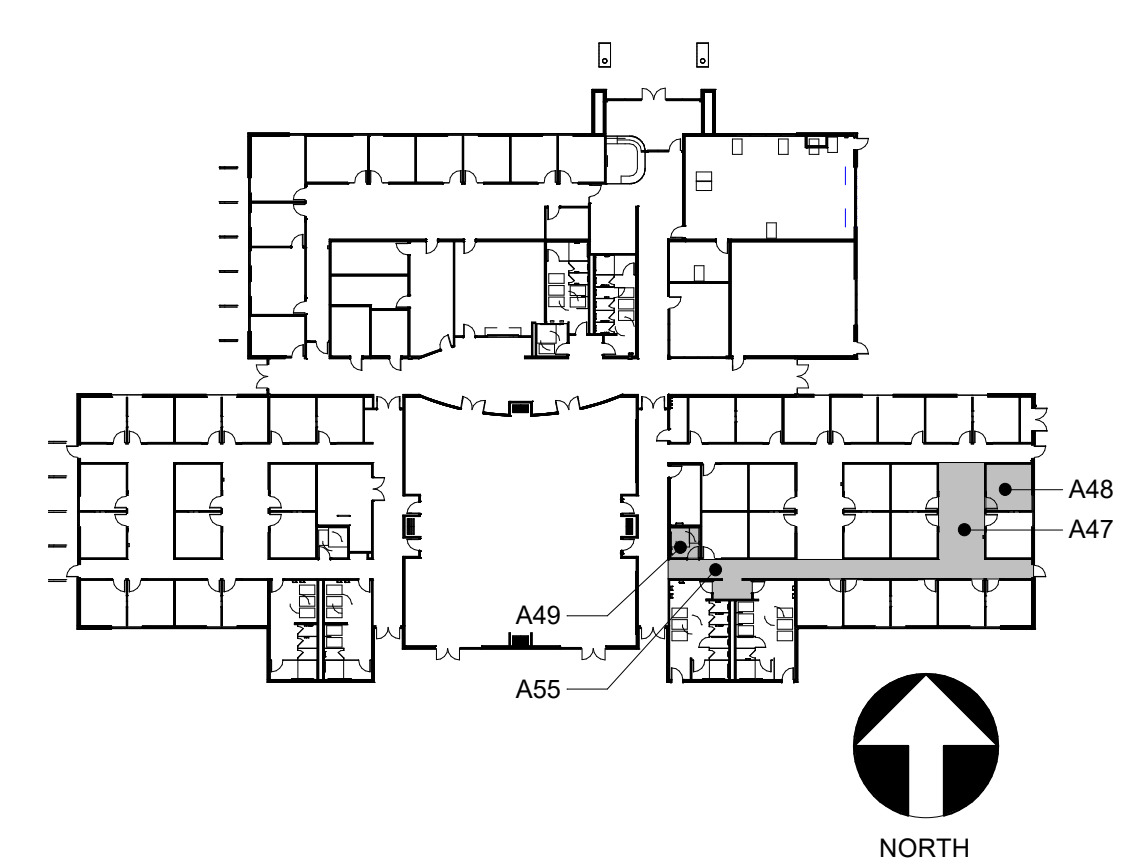

PLOT DATE: 9/13/2023 2:06:24 PM

ONLINE SCHOOL & SPECIAL EDUCATION
ADMINISTRATION DISTRICT OFFICE EXPANSION
CLOVIS UNIFIED SCHOOL DISTRICT
CLOVIS, CA
DRAWING TITLE
INTERIOR ELEVATIONS - BLDG A - ONLINE SCHOOL

PROJECT NO.
12242.00
DRAWING
A920

\\netfiles1\Users\Elizbeth.Conti_TETRI\Documents\12242-A-DO_SITE_siticontainers.rvt

IDENTIFICATION STAMP
 DIV. OF THE STATE ARCHITECT
 APP: 02-121813 INC.
 REVIEWED FOR
 SS FLS ACS
 DATE: 09/28/2023

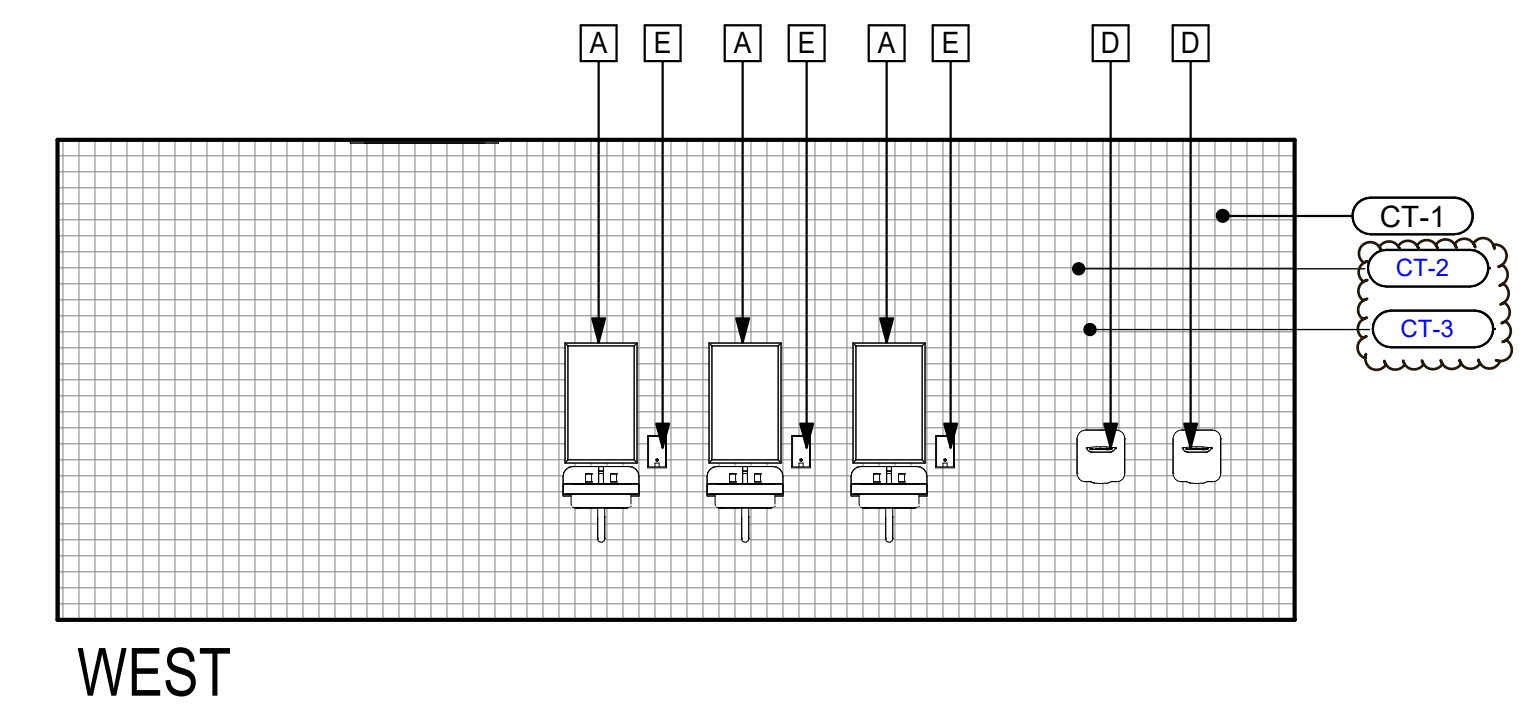
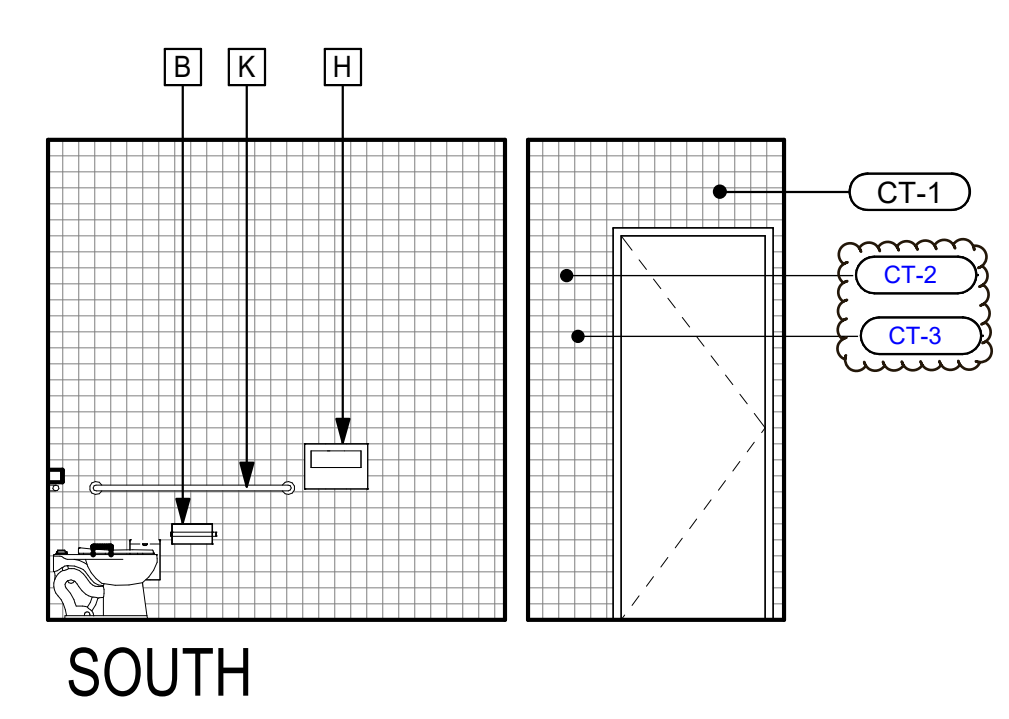
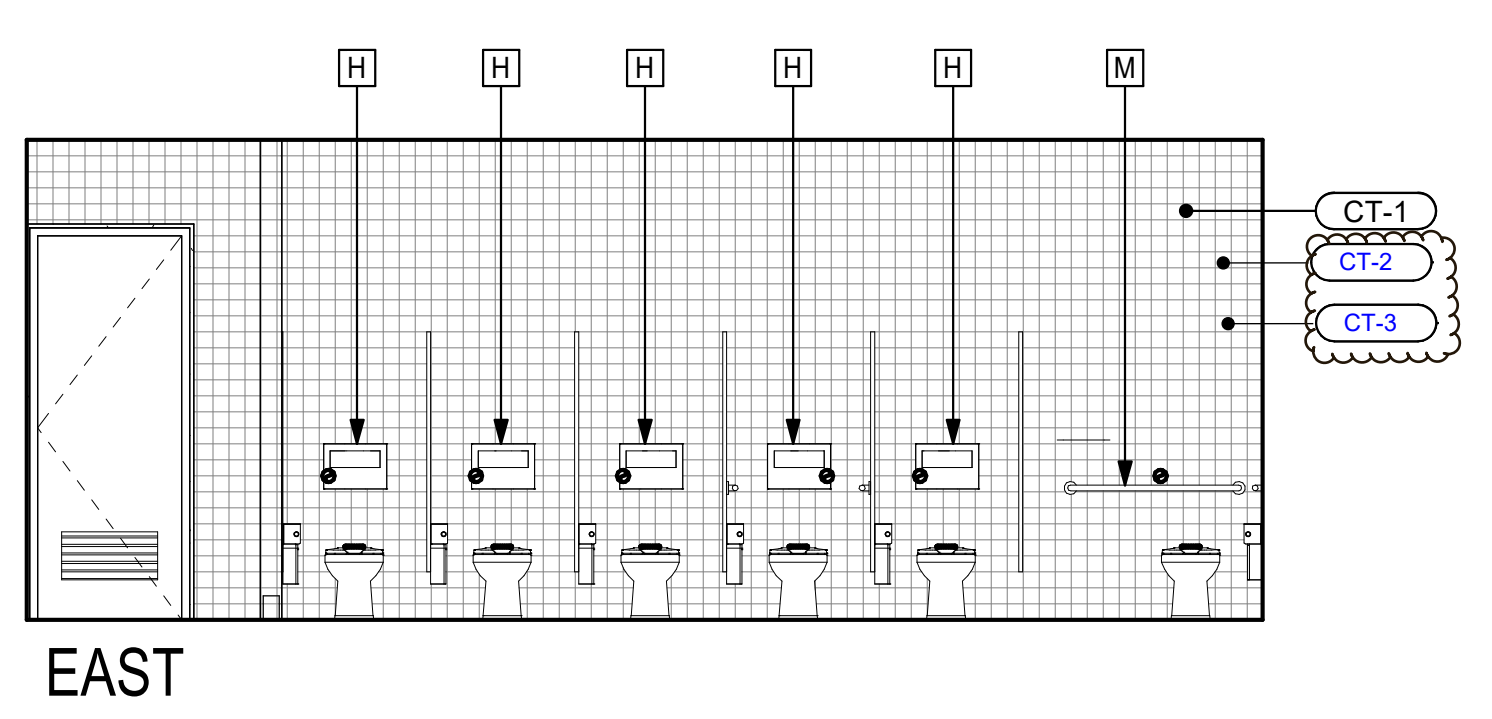
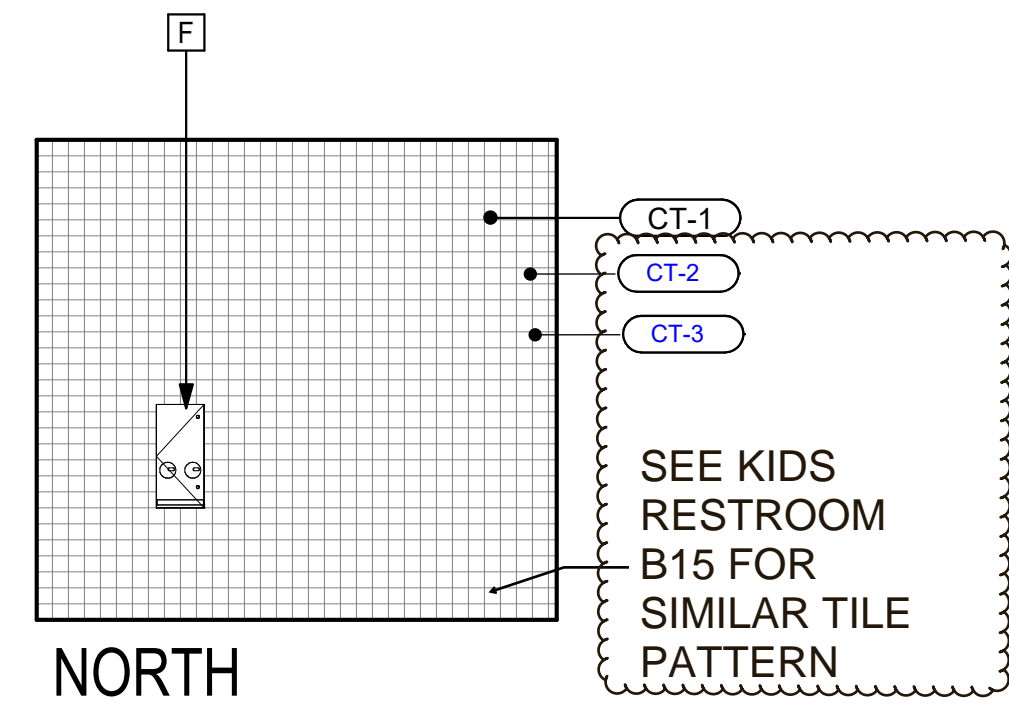

GIRLS RESTROOM - A56

1/4" = 1'-0" 6

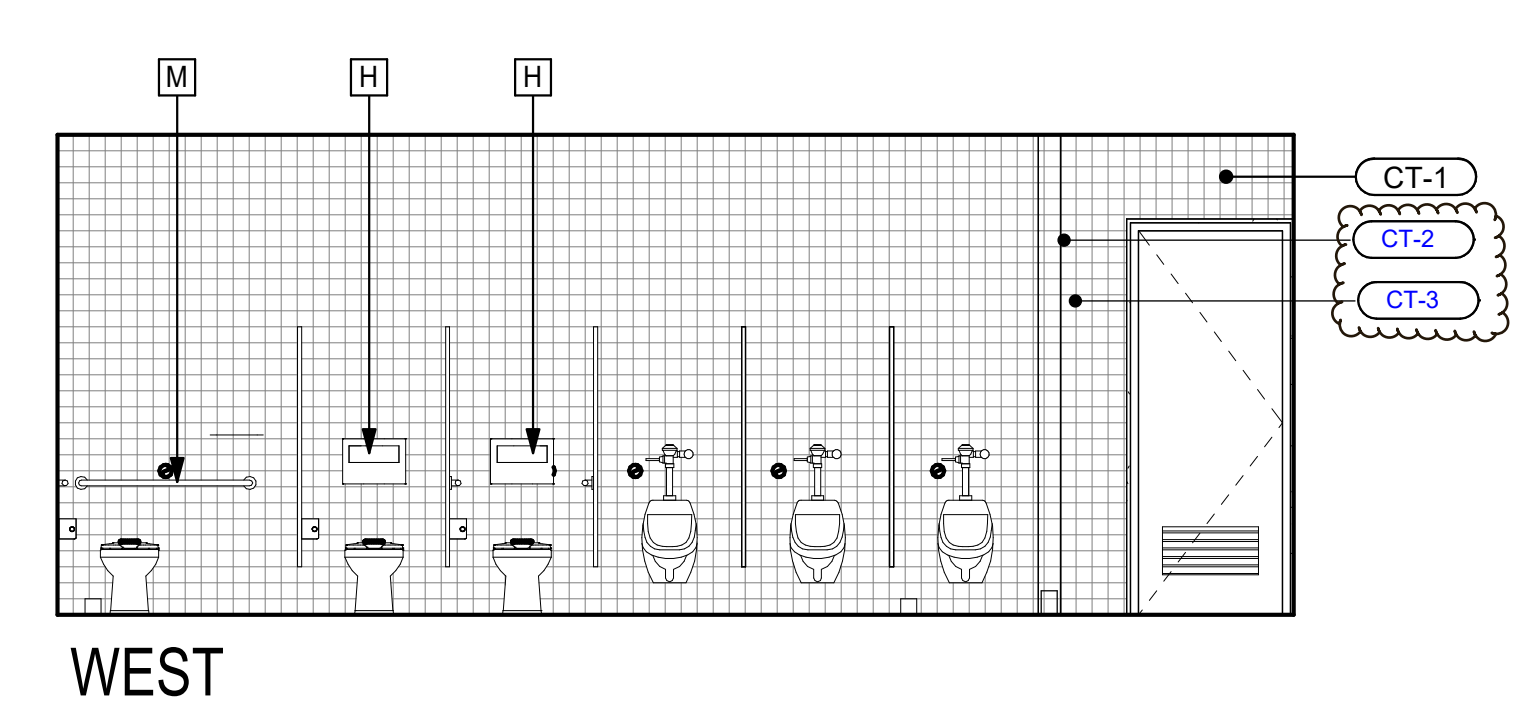
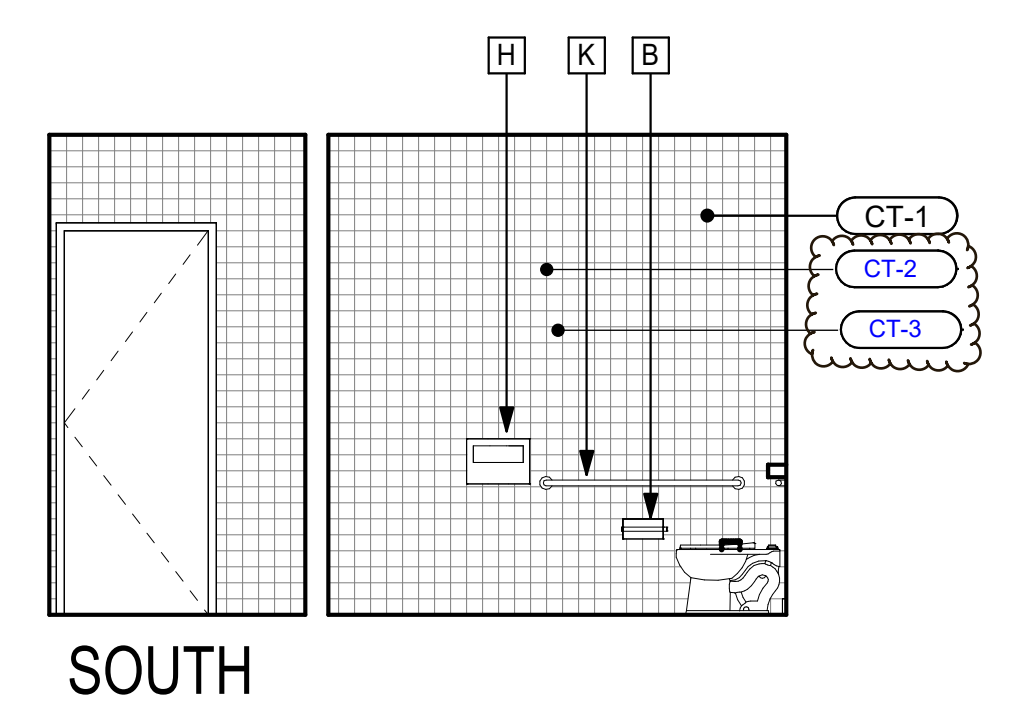
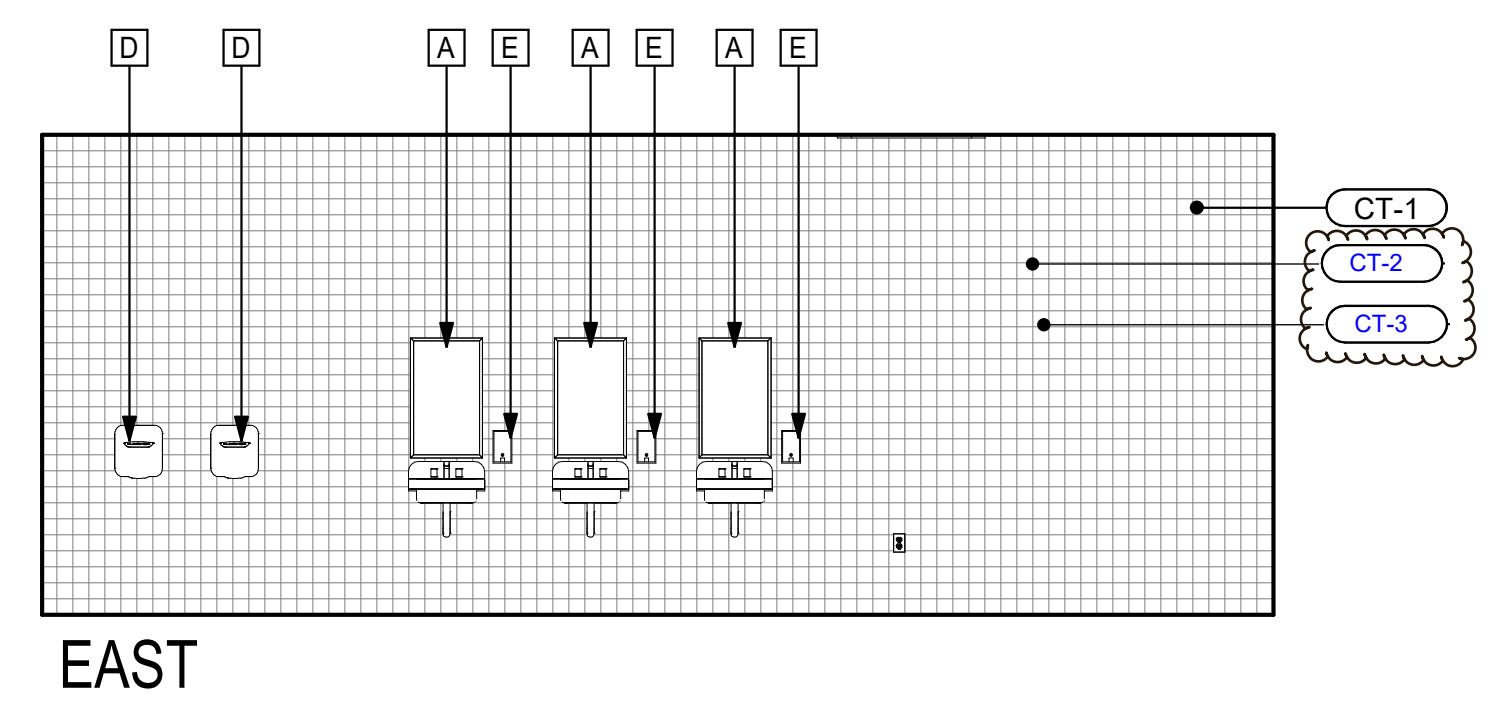
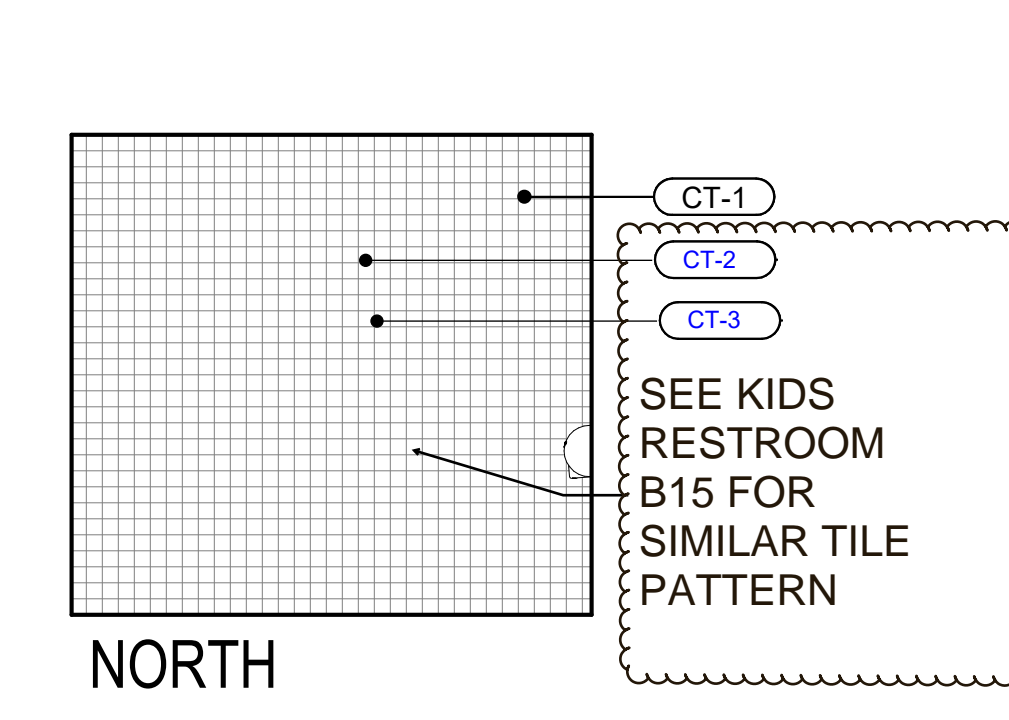

BOYS RESTROOM - A57

1/4" = 1'-0" 7

TOILET ACCESSORY SCHEDULE				
MARK	DESCRIPTION	MFR.	MODEL NO.	REMARKS
A	MIRROR (18" X 30")	BOBRICK	B-165	SURFACE MTD.
B	TOILET TISSUE DISPENSER	BRADLEY	5241	SURFACE / PARTITION MTD.
C	MOP HOLDER	BOBRICK	B-223x24	SURFACE MTD.
D	ELECTRIC HAND DRYER	EXCEL DRYER INC.	XLERATOR	SURFACED MTD.
E	SOAP DISPENSER (O.F.C.I.)	IMPACT PRODUCTS	9326 FOAMEEZE	SURFACED MTD.
F	SANITARY NAPKIN DISPENSER	BOBRICK	B-2706 25	SURFACE MTD.
G	SANITARY NAPKIN DISPOSAL UNIT	BOBRICK	B-270	SURFACE MTD./PARTITION MTD.
H	TOILET SEAT COVER DISPENSER	BOBRICK	B-221	SURFACE MTD.
J	PAPER TOWEL DISPENSER (O.F.C.I.)	GP PRO UNIVERSAL PUSH PADDLE	54338A	SURFACE MTD.
K	GRAB BAR, SIDE	BOBRICK	B-6806 SERIES	48" LONG
L	GRAB BAR, REAR	BOBRICK	B-6806 SERIES	42" LONG
M	GRAB BAR, REAR	BOBRICK	B-6806 SERIES	30" LONG

THIS DRAWING IS THE PROPERTY OF TETER, INC. AND IS TO BE USED ONLY FOR THE PROJECT AND SITE SPECIFICALLY IDENTIFIED HEREIN. IT IS TO BE KEPT IN CONFIDENCE AND NOT REPRODUCED OR TRANSMITTED IN ANY FORM OR BY ANY MEANS, ELECTRONIC OR MECHANICAL, INCLUDING PHOTOCOPYING, RECORDING, OR BY ANY INFORMATION STORAGE AND RETRIEVAL SYSTEM, WITHOUT THE WRITTEN PERMISSION OF TETER, INC.

MARK	DATE	DESCRIPTION
	7/17/23	DSA BACKCHECK



TETER, INC.
 PRESNO HEADQUARTERS
 VISALIA | BANGORFIELD | MADERA | SAN LUIS OBISPO
 ARCHITECTS ENGINEERS CONNECTED

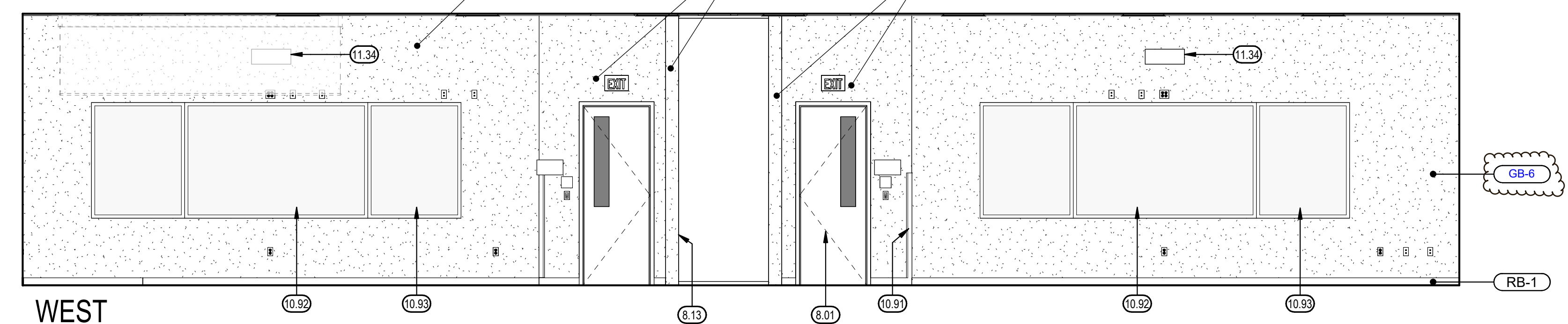
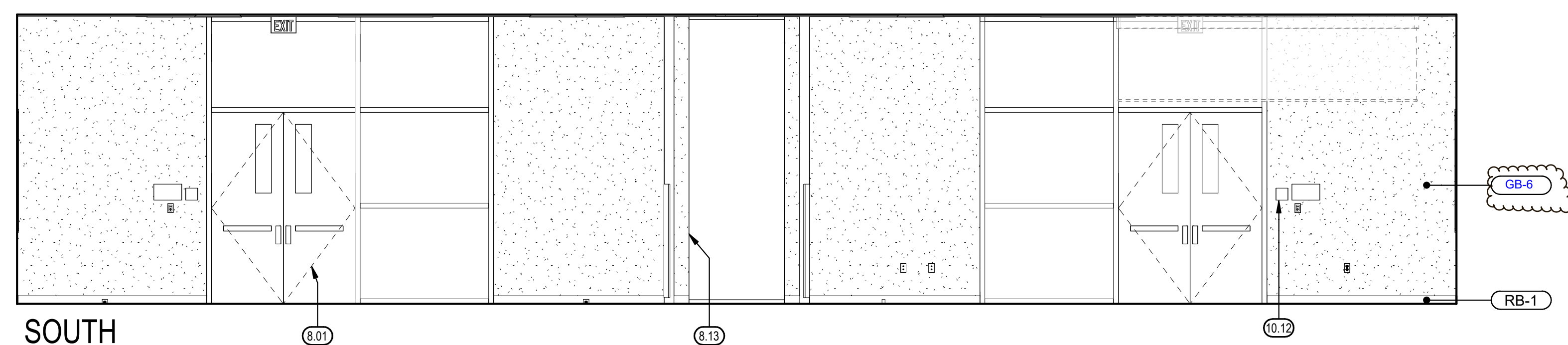
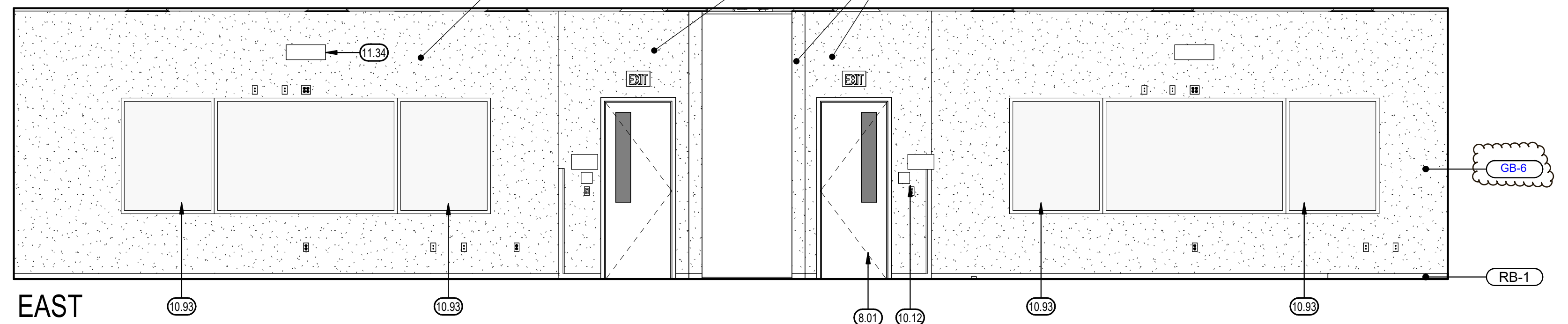
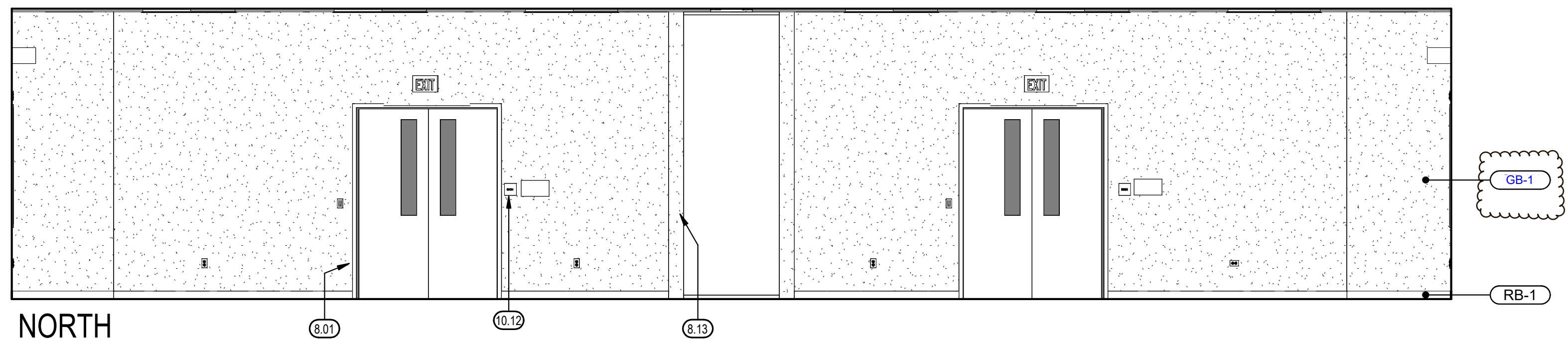
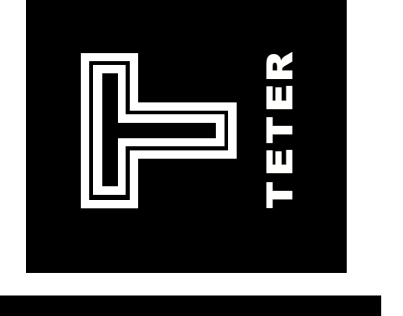

FLEX ROOMS - A63, A64, A65, A66

1/4" = 1'-0" 4

KEYNOTES

- 8.01 DOOR AND FRAME AS SCHEDULED
- 8.13 NANAWALL
- 10.12 ROOM IDENTIFICATION SIGNAGE, TYP. SEE DETAIL 3 / A801
- 10.91 CORNER GUARD, TYP. SEE DETAIL 6 / A860
- 10.92 5'X8' MARKERBOARD, SEE DETAIL 7 / A860
- 10.93 5'X4' MARKERBOARD, SEE DETAIL 7 / A860
- 11.34 WALL MOUNTED SHORT THROW PROJECTOR, SEE ELECTRICAL
- 26.03 WALL OUTLET, SEE ELECTRICAL, TYP.

GENERAL NOTES

- A. PROVIDE BLOCKING FOR ALL WALL MOUNTED ACCESSORIES AND EQUIPMENT, TYP. SEE 1 / A860
- B. FOR ACCESSIBLE FIXTURE AND ACCESSORY MOUNTING HEIGHTS AND CLEARANCES, SEE 12 / A800, 3 / A800, AND 13 / A800
- C. FOR TYPICAL CASEWORK ANCHORAGE SEE 2 / A861
- D. FOR GRAB BAR ANCHORAGE SEE 9 / A800 AND 10 / A800
- E. FOR MIRROR ANCHORAGE SEE 19 / A800 AND 20 / A800
- F. SEE INTERIOR FINISH SCHEDULE A800 AND A940 FOR ADDITIONAL INFORMATION.

KEY PLAN

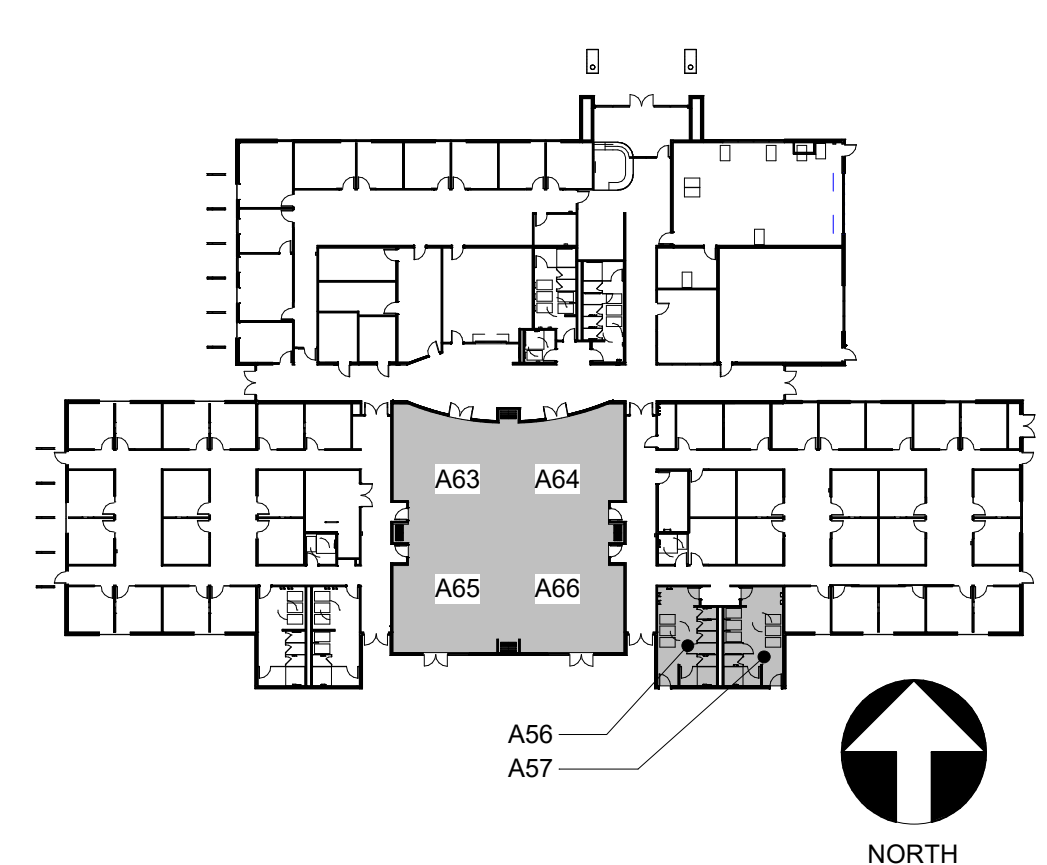

PLOT DATE: 9/13/2023 2:06:59 PM

ONLINE SCHOOL & SPECIAL EDUCATION
 ADMINISTRATION DISTRICT OFFICE EXPANSION
 CLOVIS UNIFIED SCHOOL DISTRICT
 CLOVIS, CA
 DRAWING TITLE
 INTERIOR ELEVATIONS - BLDG A - ONLINE SCHOOL

PROJECT NO.
 12242.00
 DRAWING
A921

\\net-files\1\Users\Elizabeth.Conti_TETRI\Documents\12242-A-DOO_SITE_silic.conterias.rvt

PLOT DATE: 9/13/2023 2:07:24 PM

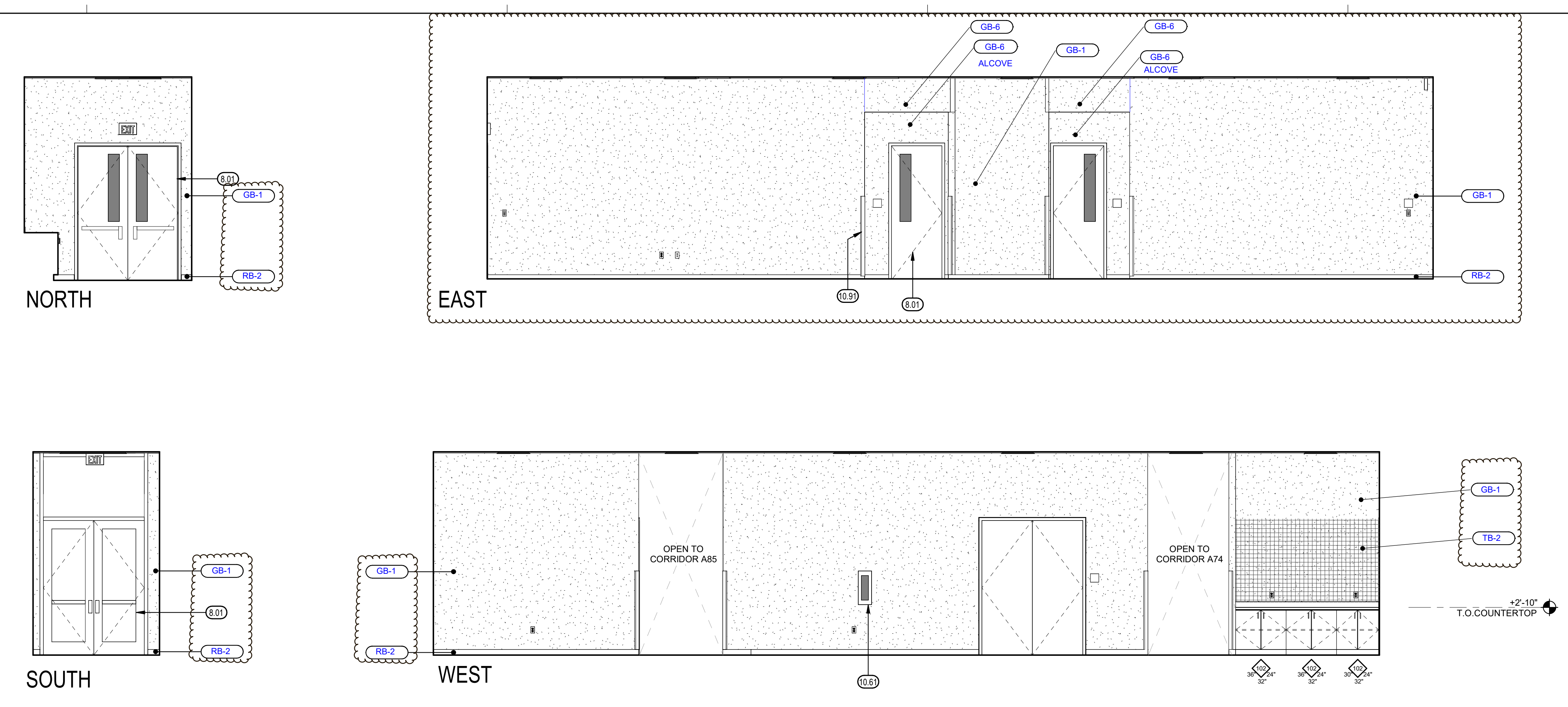

CORRIDOR 3 - A67 1/4" = 1'-0" 7



CORRIDOR 1 - A74 1/4" = 1'-0" 9

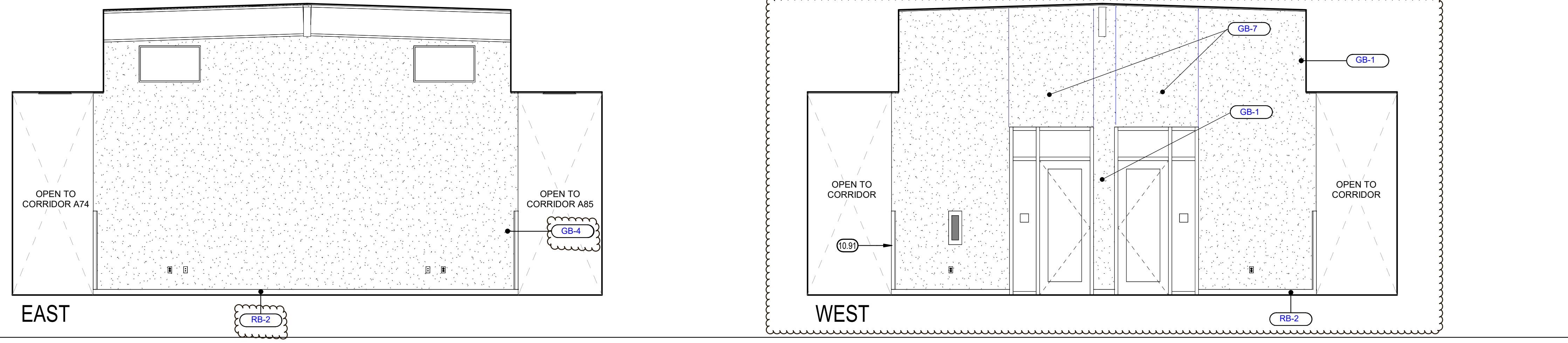

COLLABORATION SPACE - A76 1/4" = 1'-0" 10

KEYNOTES 00

- 8.01 DOOR AND FRAME AS SCHEDULED
- 10.12 ROOM IDENTIFICATION SIGNAGE, TYP. SEE DETAIL 3 / A801
- 10.61 FIRE EXTINGUISHER CABINET AND FIRE EXTINGUISHER
- 10.91 CORNER GUARD, TYP. SEE DETAIL 6 / A860

IDENTIFICATION STAMP
 DIV. OF THE STATE ARCHITECT
 APP: 02-121813 INC.
 REVIEWED FOR
 SS FLS ACS
 DATE: 09/28/2023

Mark, Date, Description, DSA Backcheck

MARK	DATE	DESCRIPTION	DSA BACKCHECK
	7/17/23		

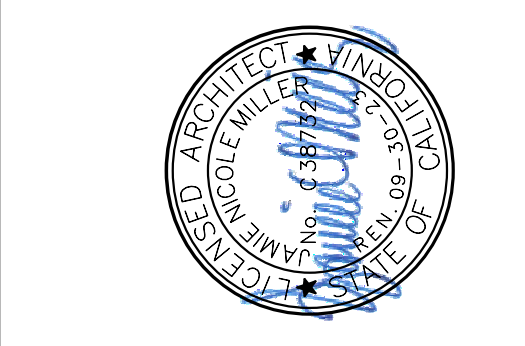

TETER, INC.
 PRESNO HEADQUARTERS
 VISALIA | BAKERSFIELD | MADERA | SAN LUIS OBISPO
 ARCHITECTS ENGINEERS CONNECTED



GENERAL NOTES

- A. PROVIDE BLOCKING FOR ALL WALL MOUNTED ACCESSORIES AND EQUIPMENT, TYP. SEE 1 / A860
- B. FOR ACCESSIBLE FIXTURE AND ACCESSORY MOUNTING HEIGHTS AND CLEARANCES, SEE 12 / A800, 3 / A800, AND 13 / A800
- C. FOR TYPICAL CASEWORK ANCHORAGE SEE 2 / A861
- D. FOR GRAB BAR ANCHORAGE SEE 9 / A800 AND 10 / A800
- E. FOR MIRROR ANCHORAGE SEE 19 / A800 AND 20 / A800
- F. SEE INTERIOR FINISH SCHEDULE A900 AND A940 FOR ADDITIONAL INFORMATION.

KEY PLAN

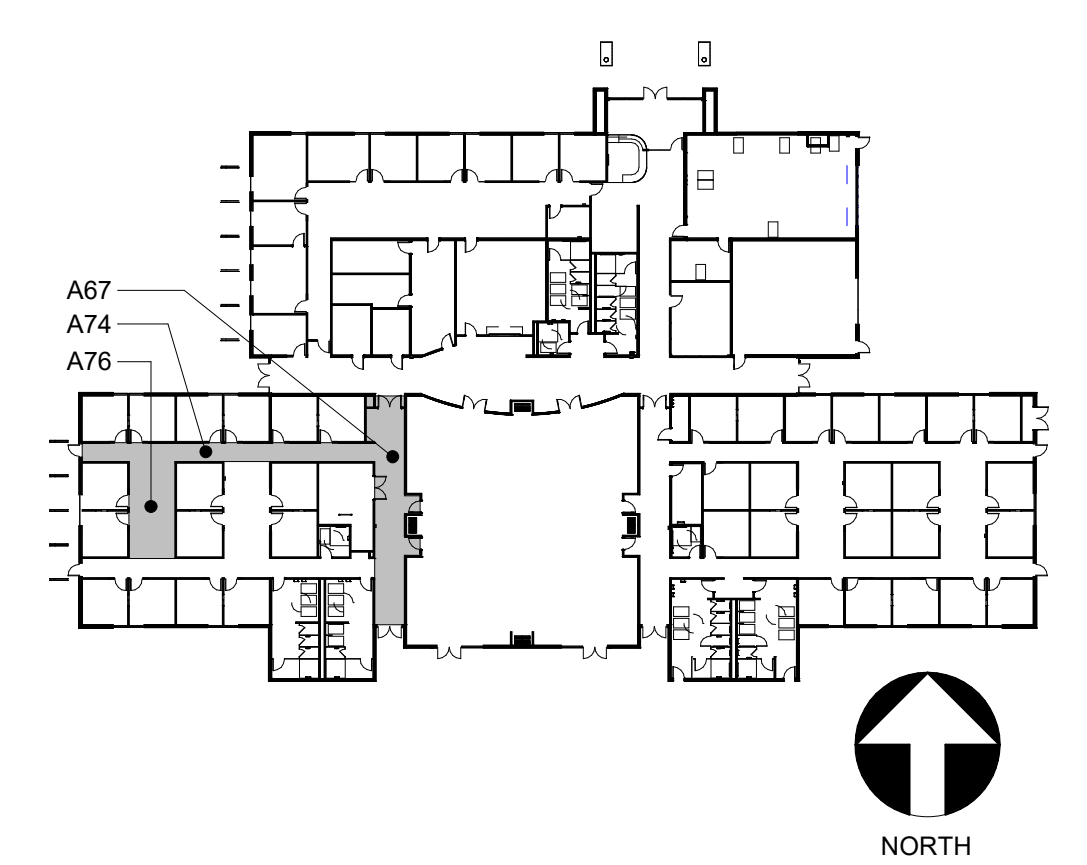

ONLINE SCHOOL & SPECIAL EDUCATION
 ADMINISTRATION DISTRICT OFFICE EXPANSION
 CLOVIS UNIFIED SCHOOL DISTRICT
 CLOVIS, CA
 DRAWING TITLE
 INTERIOR ELEVATIONS - BLDG A - ONLINE SCHOOL

PROJECT NO.
 12242.00
 DRAWING
A922

\\net-file1\Users\Elizabeth.Conti_TETRI\Documents\12242-A-DO_31TE_silic.conterias.rvt

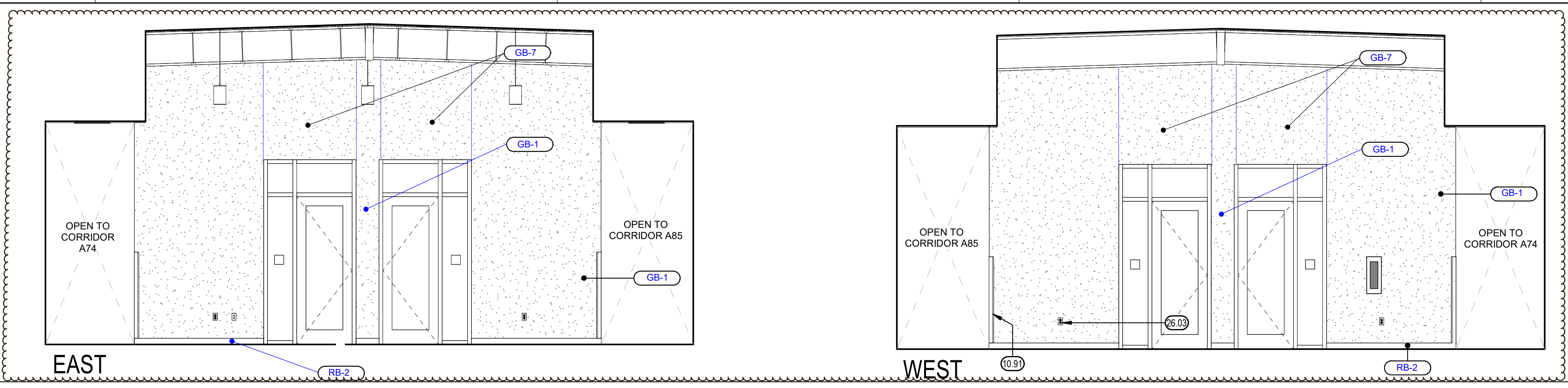

COLLABORATION SPACE - A78

1/4" = 1'-0" 6

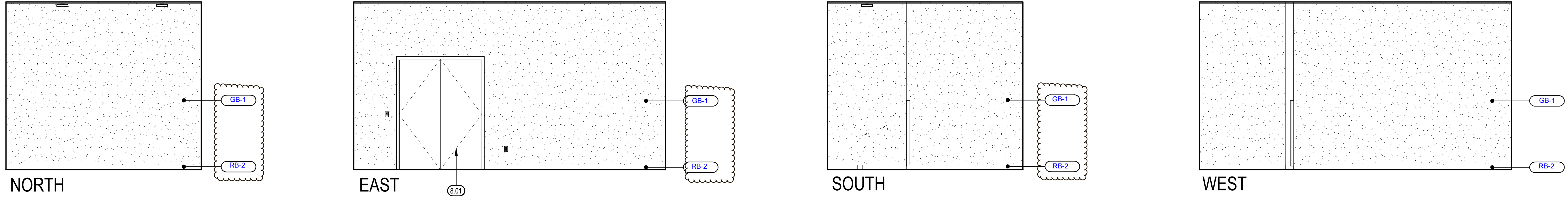

STORAGE - A80

1/4" = 1'-0" 7

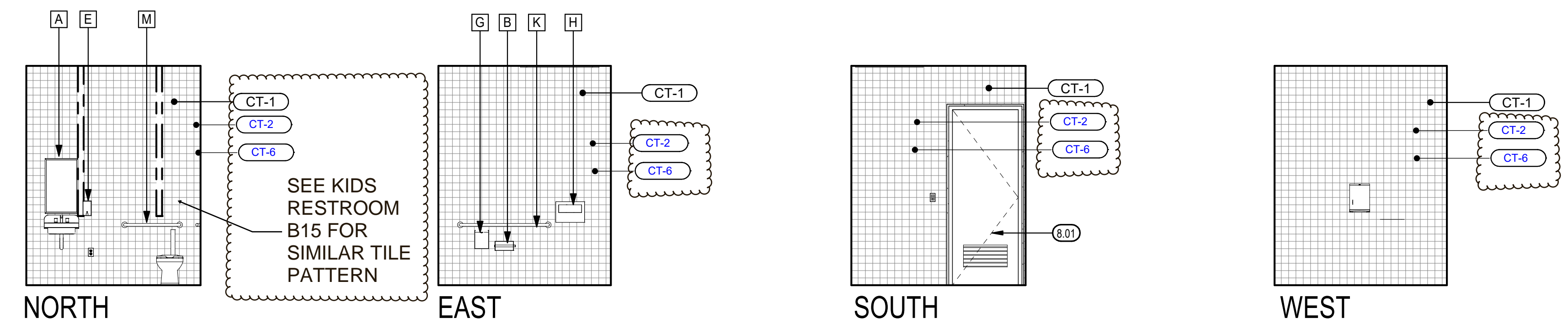

UNISEX - A84

1/4" = 1'-0" 8

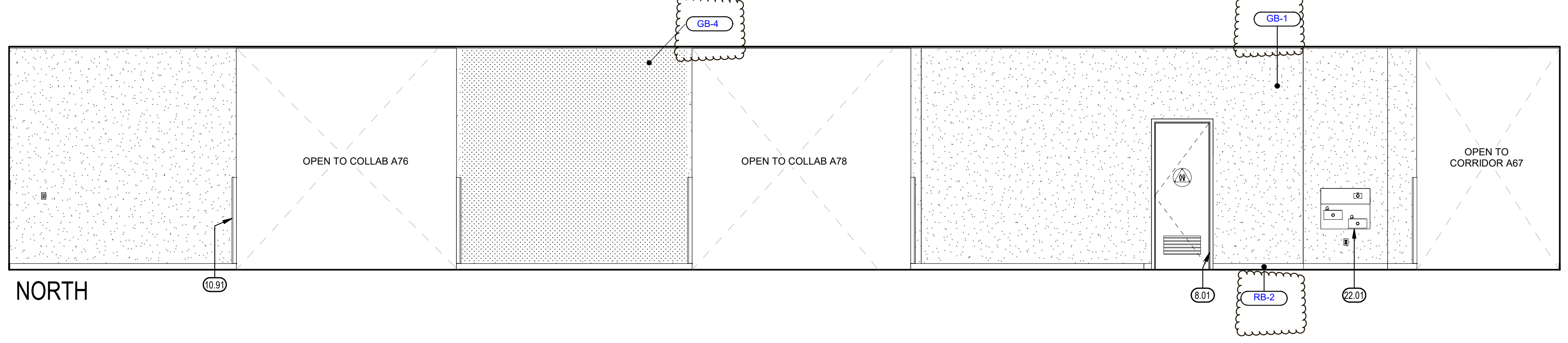

CORRIDOR 2 - A85

1/4" = 1'-0" 10

KEYNOTES 00.00

- 8.01 DOOR AND FRAME AS SCHEDULED
- 10.12 ROOM IDENTIFICATION SIGNAGE, TYP. SEE DETAIL 3 / A801
- 10.13 TOILET ROOM GEOMETRIC SYMBOLS, SEE DETAIL 5 / A801
- 10.61 FIRE EXTINGUISHER CABINET AND FIRE EXTINGUISHER
- 10.91 CORNER GUARD, TYP. SEE DETAIL 6 / A800
- 22.01 HIGH-LOW DRINKING FOUNTAIN, SEE PLUMBING, AND DETAIL 24 / A800
- 26.03 WALL OUTLET, SEE ELECTRICAL, TYP.

IDENTIFICATION STAMP
 DIV. OF THE STATE ARCHITECT
 APP: 02-121813 INC.
 REVIEWED FOR:
 SS FLS ACS
 DATE: 09/28/2023

For the purposes of this drawing, the user hereby grants the architect the right to use the drawing for the project and to reproduce the drawing in whole or in part for the project without the user's written authorization.

MARK	DATE	DESCRIPTION
	7/17/23	DSA BACKCHECK



TETER, INC.
 ARCHITECTS ENGINEERS CONNECTED
 FRESNO HEADQUARTERS
 VISALIA | BANGORFIELD | MODOSTO | SAN LUIS OBISPO

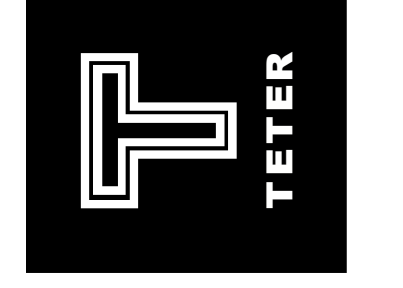

ONLINE SCHOOL & SPECIAL EDUCATION
 ADMINISTRATION DISTRICT OFFICE EXPANSION
 CLOVIS UNIFIED SCHOOL DISTRICT
 CLOVIS, CA
 DRAWING TITLE
 INTERIOR ELEVATIONS - BLDG A - ONLINE SCHOOL

TOILET ACCESSORY SCHEDULE

MARK	DESCRIPTION	MFR.	MODEL NO.	REMARKS
A	MIRROR (18" X 30")	BOBRICK	B-165	SURFACE MTD.
B	TOILET TISSUE DISPENSER	BRADLEY	5241	SURFACE / PARTITION MTD.
C	MOP HOLDER	BOBRICK	B-223x24	SURFACE MTD.
D	ELECTRIC HAND DRYER	EXCEL DRYER INC.	XLERATOR	SURFACED MTD.
E	SOAP DISPENSER (O.F.C.I.)	IMPACT PRODUCTS	9326 FOAMEEZE	SURFACED MTD.
F	SANITARY NAPKIN DISPENSER	BOBRICK	B-2706.25	SURFACE MTD.
G	SANITARY NAPKIN DISPOSAL UNIT	BOBRICK	B-270	SURFACE MTD./PARTITION MTD.
H	TOILET SEAT COVER DISPENSER	BOBRICK	B-221	SURFACE MTD.
J	PAPER TOWEL DISPENSER (O.F.C.I.)	GP PRO UNIVERSAL	54338A	SURFACE MTD.
K	GRAB BAR, SIDE	BOBRICK	B-6806 SERIES	48" LONG
L	GRAB BAR, REAR	BOBRICK	B-6806 SERIES	42" LONG
M	GRAB BAR, REAR	BOBRICK	B-6806 SERIES	30" LONG

GENERAL NOTES

- A. PROVIDE BLOCKING FOR ALL WALL MOUNTED ACCESSORIES AND EQUIPMENT, TYP. SEE 1 / A860
- B. FOR ACCESSIBLE FIXTURE AND ACCESSORY MOUNTING HEIGHTS AND CLEARANCES, SEE 12 / A800, 3 / A800, AND 13 / A800
- C. FOR TYPICAL CASEWORK ANCHORAGE SEE 2 / A861
- D. FOR GRAB BAR ANCHORAGE SEE 9 / A800 AND 10 / A800
- E. FOR MIRROR ANCHORAGE SEE 19 / A800 AND 20 / A800
- F. SEE INTERIOR FINISH SCHEDULE A900 AND A940 FOR ADDITIONAL INFORMATION.

KEY PLAN

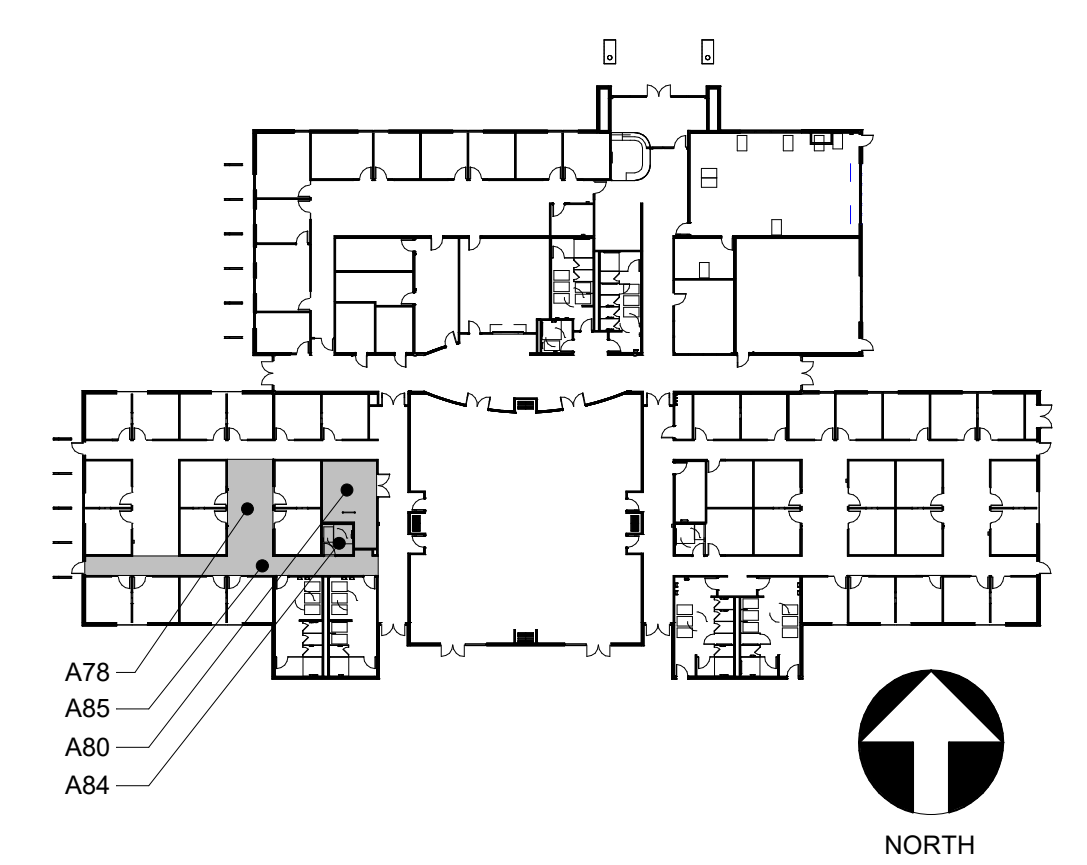

PLOT DATE: 9/13/2023 2:07:59 PM

PROJECT NO.
 12242.00
 DRAWING
A923

\\netfiles1\Users\Elizabeth.Conti_TETRI\Documents\12242-A-DO_SITE_silic.conterias.rvt

PLOT DATE: 9/13/2023 2:06:23 PM

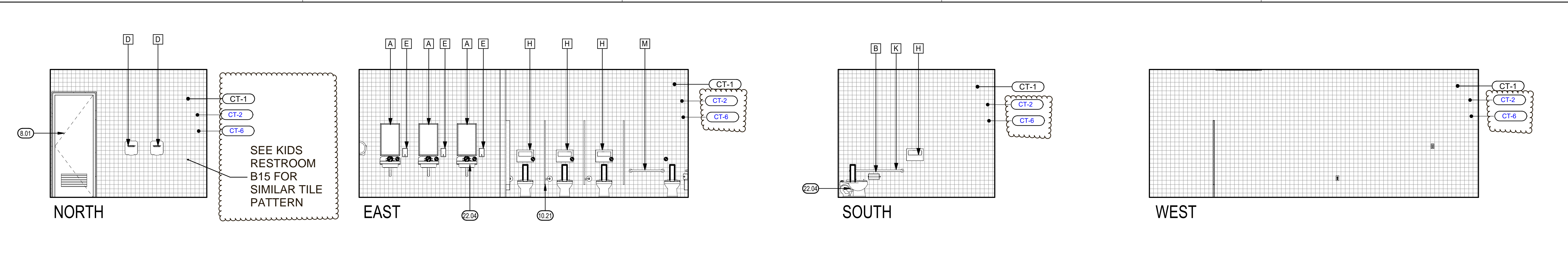

GIRLS RESTROOM - A90

1/4" = 1'-0" 6

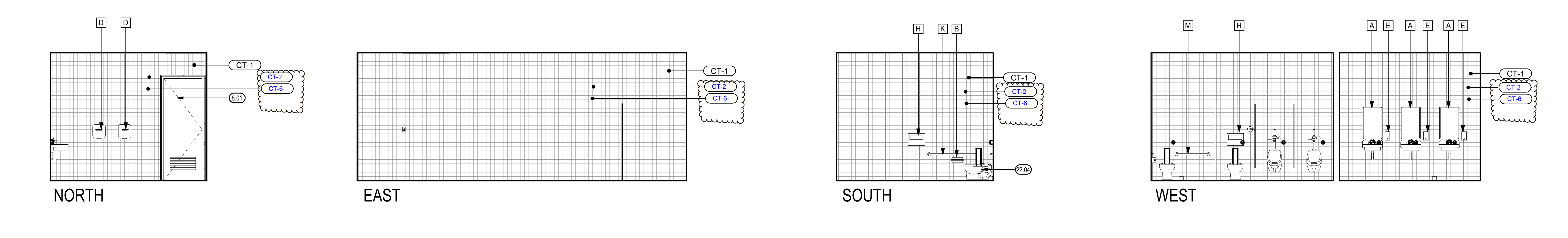

BOYS RESTROOM - A91

1/4" = 1'-0" 7

KEYNOTES

- 8.01 DOOR AND FRAME AS SCHEDULED
- 10.21 TOILET COMPARTMENT/URINAL SCREEN, SEE DETAIL 8 / A800
- 22.04 PLUMBING FIXTURE, SEE PLUMBING

IDENTIFICATION STAMP
DIV. OF THE STATE ARCHITECT
APP: 02-121813 INC.
REVIEWED FOR
SS FLS ACS
DATE: 09/28/2023

For the separate use of these drawings, the user assumes all responsibility for the accuracy and completeness of the information contained herein. This document, the drawings, and the information contained herein, are the property of TETER, INC. and shall remain confidential. No part of this document, the drawings, or the information contained herein, may be reproduced, stored in a retrieval system, or transmitted in any form or by any means, electronic, mechanical, photocopying, recording, or by any information storage and retrieval system, without the prior written authorization of TETER, INC.

MARK	DATE	DESCRIPTION
	7/17/23	DSA BACKCHECK



TETER, INC.
FRESNO HEADQUARTERS
VISALIA | BAKERSFIELD | MADERA | SAN LUIS OBISPO
ARCHITECTS ENGINEERS CONNECTED

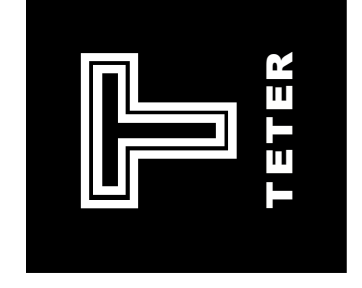

ONLINE SCHOOL & SPECIAL EDUCATION
ADMINISTRATION DISTRICT OFFICE EXPANSION
CLOVIS UNIFIED SCHOOL DISTRICT
CLOVIS, CA
DRAWING TITLE
INTERIOR ELEVATIONS - BLDG A - ONLINE SCHOOL

TOILET ACCESSORY SCHEDULE

MARK	DESCRIPTION	MFR.	MODEL NO.	REMARKS
A	MIRROR (18" X 30")	BOBRICK	B-165	SURFACE MTD.
B	TOILET TISSUE DISPENSER	BRADLEY	5241	SURFACE / PARTITION MTD.
C	MOP HOLDER	BOBRICK	B-223x24	SURFACE MTD.
D	ELECTRIC HAND DRYER	EXCEL DRYER INC.	XLERATOR	SURFACED MTD.
E	SOAP DISPENSER (O.F.C.I.)	IMPACT PRODUCTS	0326 FOAMEEZE	SURFACED MTD.
F	SANITARY NAPKIN DISPENSER	BOBRICK	B-2706 25	SURFACE MTD.
G	SANITARY NAPKIN DISPOSAL UNIT	BOBRICK	B-270	SURFACE MTD./PARTITION MTD.
H	TOILET SEAT COVER DISPENSER	BOBRICK	B-221	SURFACE MTD.
J	PAPER TOWEL DISPENSER (O.F.C.I.)	GP PRO UNIVERSAL PUSH PADDLE	54338A	SURFACE MTD.
K	GRAB BAR, SIDE	BOBRICK	B-6806 SERIES	48" LONG
L	GRAB BAR, REAR	BOBRICK	B-6806 SERIES	42" LONG
M	GRAB BAR, REAR	BOBRICK	B-6806 SERIES	30" LONG

GENERAL NOTES

- A. PROVIDE BLOCKING FOR ALL WALL MOUNTED ACCESSORIES AND EQUIPMENT, TYP. SEE 1 / A800
- B. FOR ACCESSIBLE FIXTURE AND ACCESSORY MOUNTING HEIGHTS AND CLEARANCES, SEE 12 / A800, 3 / A800, AND 13 / A800
- C. FOR TYPICAL CASEWORK ANCHORAGE SEE 2 / A861
- D. FOR GRAB BAR ANCHORAGE SEE 9 / A800 AND 10 / A800
- E. FOR MIRROR ANCHORAGE SEE 19 / A800 AND 20 / A800
- F. SEE INTERIOR FINISH SCHEDULE A900 AND A940 FOR ADDITIONAL INFORMATION.

KEY PLAN

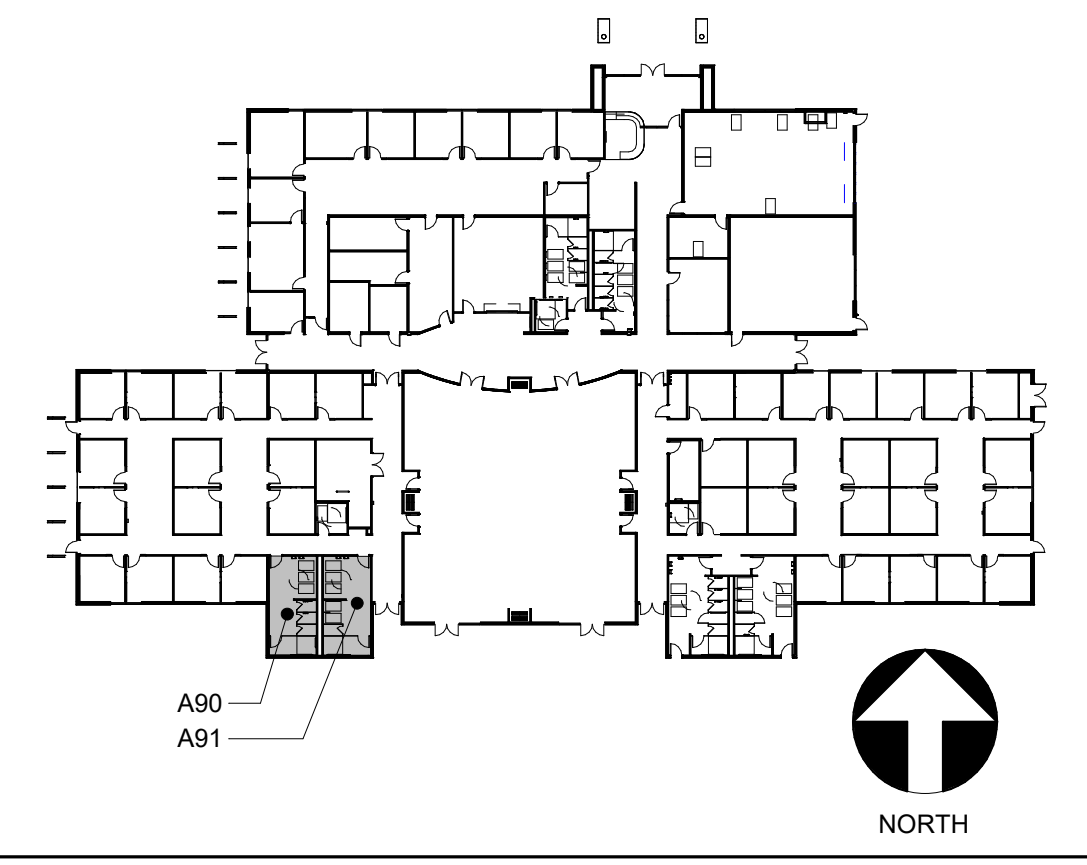

PROJECT NO.
12242.00
DRAWING
A924

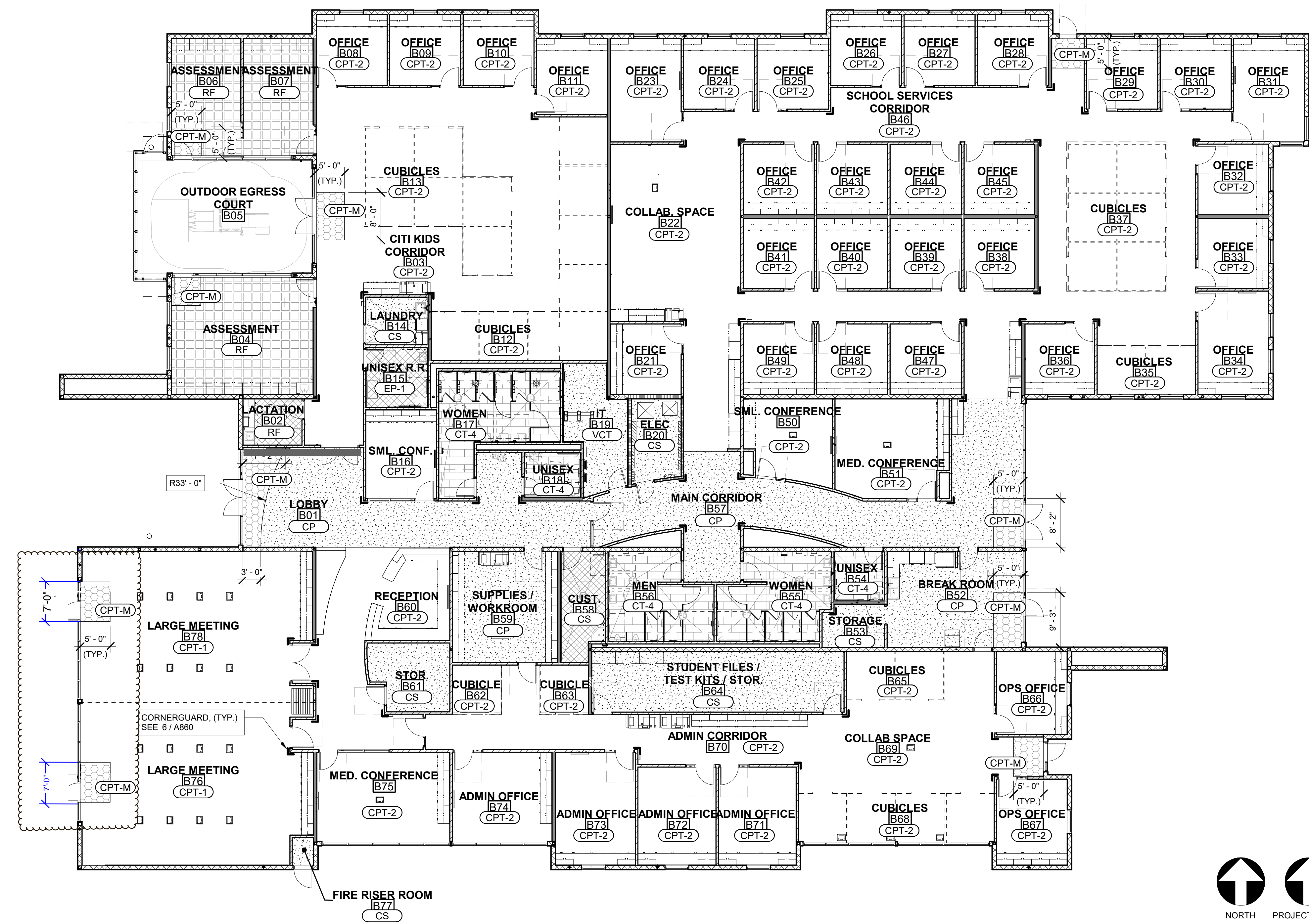

GENERAL NOTES

- SEE INTERIOR ELEVATIONS FOR WAINSCOT/MATERIAL HEIGHT.

REMARKS

- A. AT EXPOSED CEILING LOCATIONS, PAINT ALL EXPOSED STRUCTURE, DUCTS, PIPING, UNDERSIDE OF INSULATION, PROVIDE 1" X 1" CONT. METAL TRIM PAINTED WHERE INSULATION MEETS WALL.
- B. 4" X 8" ALUM. FRAMED TACKBOARD PANELS OVER PAINTED GYPSUM BOARD.
- C. CERAMIC TILE COVE BASE.
- D. CUBICLES/FURNITURE BY OWNER.
- E. SEE EXTERIOR FINISH SCHEDULE FOR ADDITIONAL PLYWOOD INFORMATION.
- F. SEE ELECTRICAL SPEC FOR ADDITIONAL PLYWOOD INFORMATION.
- G. GB-5 AT RESTROOM ALCOVE.

FLOOR FINISH PLAN - BLDG B - SPECIAL EDUCATION ADMINISTRATION

3/32" = 1'-0" 3

ROOM FINISH SCHEDULE - SPECIAL EDUCATION ADMIN

#	ROOM NAME	FLOOR	BASE	NORTH	EAST	SOUTH	WEST	CEILING	EXPOSED COUNTERTOPS & BACKSPASH	EXPOSED CASEWORK	REMARKS
B01	LOBBY	CPT-M	RB-2	GB-1	GB-1	GB-1	GB-1	ACP	PL-2/SS-1	PL-1	
B02	LACTATION	RF	RB-2	GB-1	GB-2	GB-1	GB-1	ACP	PL-2	PL-1	
B03	CITI KIDS CORRIDOR	CPT-2	RB-2	GB-1	GB-1	GB-1	GB-1	ACP	PL-2	PL-1	
B04	ASSESSMENT	RF	RB-2	GB-1	GB-1	GB-1	GB-1	ACP	PL-2	PL-1	
B05	OUTDOOR EGRESS COURT	SEE 3/A940	--	--	--	--	--	SEE SHEET A950	--	--	E
B06	ASSESSMENT	RF/CPT-M	RB-2	GB-1	GB-1	GB-1	GB-1	ACP	PL-2	PL-1	
B07	ASSESSMENT	RF	RB-2	GB-1	GB-1	GB-1	GB-1	ACP	PL-2	PL-1	
B08	OFFICE	CPT-2	RB-2	GB-2	GB-1	GB-1	GB-1	ACP	PL-2	PL-1	
B09	OFFICE	CPT-2	RB-2	GB-2	GB-1	GB-1	GB-1	ACP	PL-2	PL-1	
B10	OFFICE	CPT-2	RB-2	GB-2	GB-1	GB-1	GB-1	ACP	PL-2	PL-1	
B11	OFFICE	CPT-2	RB-2	GB-2	GB-1	GB-1	GB-1	ACP	PL-2	PL-1	
B12	CUBICLES	CPT-2	RB-2	GB-1	GB-1	GB-1	GB-1	ACP	PL-2	PL-1	
B13	CUBICLES	CPT-2/CPT-M	RB-2	GB-1	GB-1	GB-1	GB-1	ACP	PL-2	PL-1	D
B14	LAUNDRY	CS	RB-2	GB-3	GB-3	GB-3	GB-3	EXP	GB-3	PL-1	
B15	UNISEX R.R.	EP-1	EP-1	CT-1/CT-2/CT-7	CT-1/CT-2/CT-7	CT-1/CT-2/CT-7	CT-1/CT-2/CT-7	GB-3	GB-3	PL-1	
B16	SML CONF.	CPT-2	RB-2	GB-2	GB-1	GB-1	GB-1	ACP	PL-2	PL-1	
B17	WOMEN	CT-4	CT-4	CT-5	CT-5	CT-5	CT-5	GB-3	GB-3	PL-1	
B18	UNISEX	CT-4	CT-4	CT-5	CT-5	CT-5	CT-5	GB-3	GB-3	PL-1	
B19	IT	VCT	RB-2	GB-1PW	GB-1PW	GB-1PW	GB-1PWE	EXP	EXP	PL-1	F
B20	ELEC	CS	RB-2	GB-1	GB-1	GB-1	GB-1	EXP	EXP	PL-1	
B21	OFFICE	CPT-2	RB-2	GB-1	GB-1	GB-1	GB-2	ACP	PL-2	PL-1	
B22	COLLAB SPACE	CPT-2	RB-2	GB-1	GB-1/GB-4	GB-1	GB-1	ACP	PL-2	PL-1	
B23	OFFICE	CPT-2	RB-2	GB-2	GB-1	GB-1	GB-1	ACP	PL-2	PL-1	
B24	OFFICE	CPT-2	RB-2	GB-2	GB-1	GB-1	GB-1	ACP	PL-2	PL-1	
B25	OFFICE	CPT-2	RB-2	GB-2	GB-1	GB-1	GB-1	ACP	PL-2	PL-1	
B26	OFFICE	CPT-2	RB-2	GB-2	GB-1	GB-1	GB-1	ACP	PL-2	PL-1	
B27	OFFICE	CPT-2	RB-2	GB-2	GB-1	GB-1	GB-1	ACP	PL-2	PL-1	
B28	OFFICE	CPT-2	RB-2	GB-2	GB-1	GB-1	GB-1	ACP	PL-2	PL-1	
B29	OFFICE	CPT-2	RB-2	GB-2	GB-1	GB-1	GB-1	ACP	PL-2	PL-1	
B30	OFFICE	CPT-2	RB-2	GB-2	GB-1	GB-1	GB-1	ACP	PL-2	PL-1	
B31	OFFICE	CPT-2	RB-2	GB-2	GB-1	GB-1	GB-1	ACP	PL-2	PL-1	
B32	OFFICE	CPT-2	RB-2	GB-2	GB-1	GB-1	GB-1	ACP	PL-2	PL-1	
B33	OFFICE	CPT-2	RB-2	GB-2	GB-1	GB-1	GB-1	ACP	PL-2	PL-1	
B34	OFFICE	CPT-2	RB-2	GB-1	GB-1	GB-1	GB-2	ACP	PL-2	PL-1	
B35	CUBICLES	CPT-2	RB-2	GB-1	GB-1	GB-1	GB-2	ACP	PL-2	PL-1	D
B36	OFFICE	CPT-2	RB-2	GB-1	GB-1	GB-1	GB-2	ACP	PL-2	PL-1	
B37	CUBICLES	CPT-2/CPT-M	RB-2	GB-2	GB-1	GB-1	GB-1/GB-4	ACP	PL-2	PL-1	D
B38	OFFICE	CPT-2	RB-2	GB-2	GB-1	GB-1	GB-1	ACP	PL-2	PL-1	
B39	OFFICE	CPT-2	RB-2	GB-2	GB-1	GB-1	GB-1	ACP	PL-2	PL-1	
B40	OFFICE	CPT-2	RB-2	GB-2	GB-1	GB-1	GB-1	ACP	PL-2	PL-1	

ROOM FINISH SCHEDULE - SPECIAL EDUCATION ADMIN

#	ROOM NAME	FLOOR	BASE	NORTH	EAST	SOUTH	WEST	CEILING	EXPOSED COUNTERTOPS & BACKSPASH	EXPOSED CASEWORK	REMARKS
B41	OFFICE	CPT-2	RB-2	GB-2	GB-1	GB-1	GB-1	ACP	PL-2	PL-1	
B42	OFFICE	CPT-2	RB-2	GB-1	GB-1	GB-1	GB-1	ACP	PL-2	PL-1	
B43	OFFICE	CPT-2	RB-2	GB-1	GB-1	GB-1	GB-1	ACP	PL-2	PL-1	
B44	OFFICE	CPT-2	RB-2	GB-1	GB-1	GB-2	GB-1	ACP	PL-2	PL-1	
B45	OFFICE	CPT-2	RB-2	GB-1	GB-1	GB-2	GB-1	ACP	PL-2	PL-1	
B46	SCHOOL SERVICES CORRIDOR	CPT-2	RB-2	GB-1	GB-1	GB-1/GB-4	GB-1	ACP	PL-2	PL-1	
B47	OFFICE	CPT-2	RB-2	GB-1	GB-1	GB-2	GB-1	ACP	PL-2	PL-1	
B48	OFFICE	CPT-2	RB-2	GB-1	GB-1	GB-2	GB-1	ACP	PL-2	PL-1	
B49	OFFICE	CPT-2	RB-2	GB-1	GB-1	GB-2	GB-1	ACP	PL-2	PL-1	
B50	SML CONFERENCE	CPT-2	RB-2	GB-1	GB-1	GB-2	GB-1	ACP	PL-2	PL-1	
B51	MED. CONFERENCE	CPT-2	RB-2	GB-1	GB-1	GB-1	GB-1	ACP	PL-2	PL-1	
B52	BREAK ROOM	CP	RB-2	GB-1	GB-1	GB-1	GB-1	ACP	PL-2	PL-1	
B53	STORAGE	CS	RB-2	GB-1	GB-1	GB-1	GB-1	EXP	GB-1	PL-1	
B54	UNISEX	CT-4	CT-4	CT-5	CT-5	CT-5	CT-5	GB-3	GB-3	PL-1	
B55	WOMEN	CT-4	CT-4	CT-5	CT-5	CT-5	CT-5	GB-3	GB-3	PL-1	
B56	MEN	CT-4	CT-4	CT-5	CT-5	CT-5	CT-5	GB-3	GB-3	PL-1	
B57	MAIN CORRIDOR	CP	RB-2	GB-1	GB-1	GB-1/GB-5	GB-1/GB-5	ACP/GB-1/GB-5	ACP/GB-1/GB-5	PL-1	
B58	CUST.	FRP-1	FRP-1	FRP-1	FRP-1	FRP-1	FRP-1	EXP	FRP-1	PL-1	
B59	SUPPLIES / WORKROOM	CP	RB-2	FRP-1	FRP-1	FRP-1	FRP-1	EXP	FRP-1	PL-1	
B60	RECEPTION	CPT-2	RB-2	GB-1	GB-1	GB-1	GB-1	ACP	PL-2/SS-1	PL-1	
B61	STOR.	CS	RB-2	GB-1	GB-1	GB-1	GB-1	EXP	GB-1	PL-1	
B62	CUBICLE	CPT-2	RB-2	GB-1	GB-1	GB-1	GB-1	ACP	PL-2	PL-1	
B63	CUBICLE	CPT-2	RB-2	GB-1	GB-1	GB-1	GB-1	ACP	PL-2	PL-1	
B64	STUDENT FILES / TEST KITS / STOR.	CS	RB-2	GB-1	GB-1	GB-1	GB-1	ACP	PL-2	PL-1	
B65	CUBICLES	CPT-2	RB-2	GB-1	GB-1	GB-1	GB-1	ACP	PL-2	PL-1	
B66	OPS OFFICE	CPT-2	RB-2	GB-1	GB-1	GB-1	GB-1	ACP	PL-2	PL-1	
B67	OPS OFFICE	CPT-2	RB-2	GB-1	GB-1	GB-1	GB-1	ACP	PL-2	PL-1	
B68	CUBICLES	CPT-2	RB-2	GB-1	GB-1	GB-1	GB-1	ACP	PL-2	PL-1	
B69	COLLAB SPACE	CPT-2	RB-2	GB-1	GB-1	GB-1	GB-1	ACP	PL-2	PL-1	
B70	ADMIN CORRIDOR	CPT-2	RB-2	GB-1	GB-1	GB-1	GB-1	ACP	PL-2	PL-1	
B71	ADMIN OFFICE	CPT-2	RB-2	GB-1	GB-1	GB-1	GB-1	ACP	PL-2	PL-1	
B72	ADMIN OFFICE	CPT-2	RB-2	GB-1	GB-1	GB-1	GB-1	ACP	PL-2	PL-1	
B73	ADMIN OFFICE	CPT-2	RB-2	GB-1	GB-1	GB-1	GB-1	ACP	PL-2	PL-1	
B74	ADMIN OFFICE	CPT-2	RB-2	GB-1	GB-1	GB-1	GB-1	ACP	PL-2	PL-1	
B75	MED. CONFERENCE	CPT-2	RB-2	GB-1	GB-2	GB-1	GB-1	ACP	PL-2	PL-1	
B76	LARGE MEETING	CPT-1	RB-1	GB-2/GB-1	GB-1	GB-1	GB-1	ACP/GB-1	PL-2	PL-1	
B77	FIRE RISER ROOM	CS	RB-2	GB-1	GB-1	GB-1	GB-1	EXP	EXP	PL-1	
B78	LARGE MEETING	CPT-1	RB-1	GB-1	GB-2/GB-1	GB-1	GB-1	ACP/GB-1	PL-2	PL-1	

ABBREVIATIONS

ACP	SUSPENDED ACOUSTICAL CEILING PANEL	CT-1	CERAMIC WALL TILE (FIELD, WHITE)	FRP-1	FIBERGLASS REINFORCED PANEL	RB-1	TOPSET RUBBER BASE (BLUE)
CP	CONCRETE, POLISHED	CT-2	CERAMIC WALL TILE (ACCENT, GRAY)	GB-1	GYP BD., PAINT (WHITE)	RB-2	TOPSET RUBBER BASE (GRAY)
CPT-1	OCFC CARPET	CT-3	CERAMIC WALL TILE (ACCENT, DARK BLUE)	GB-2	GYP BD., PAINT (GRAY BLUE)	RF	RUBBER FLOORING
CPT-2	CARPET	CT-4	FLOOR TILE (FIELD)	GB-3	GYP BD., PAINT (WHITE SEMI GLOSS)	SS-1	SOLID SURFACE
CPT-3	CARPET	CT-5	WALL TILE (FIELD)	GB-4	GYP BD., LEVEL 4 FINISH FOR GRAPHIC WALLCOVERING (IMAGE TO BE SELECTED BY OWNER)	SS-2	SOLID SURFACE
CPT-M	CARPET	CT-6	CERAMIC WALL TILE (ACCENT, DARK GREEN)	GB-5	GYP BD., PAINT (GRAY)	TB-1	ALUMINUM FRAMED TACKBOARD
CS	CONCRETE, SEALED	CT-7	CERAMIC WALL TILE (ACCENT, LIGHT BLUE)	GB-6	GYP BD., PAINT (BLUE)	TB-2	TACKABLE WALL PANEL w/TAPED GYP BD.
		EP-1	RESINOUS FLOORING	GB-7	GYP BD., PAINT (GREEN)	VCT	VINYL COMPOSITION TILE
		ER	EPOXY RESIN LAB COUNTERTOP	PL-1	PLASTIC LAMINATE CABINET		
		EXP-1	EXPOSED, NOT FINISH	PL-2	PLASTIC LAMINATE COUNTERTOP		
		EXP-2	NOT USED	PW	PLYWOOD WITH INTUMESCENT PAINT		
		EXP-3	EXPOSED, PAINTED (WHITE)				

Mark, Date, Description, DSA BACKCHECK, 7/17/23

MARK	DATE	DESCRIPTION	DSA BACKCHECK

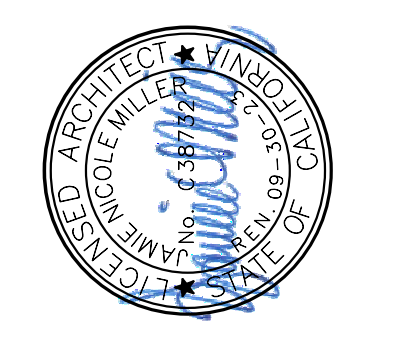

TETER, INC.
FRESNO HEADQUARTERS
VISUAL | BAKERSFIELD | MADERA | SAN LUIS OBISPO
ARCHITECTS ENGINEERS CONNECTED

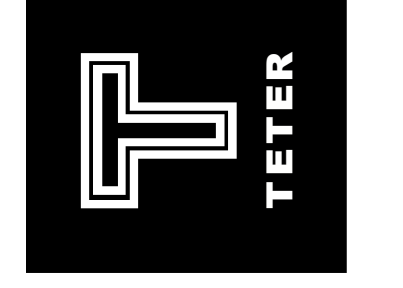

ONLINE SCHOOL & SPECIAL EDUCATION ADMINISTRATION DISTRICT OFFICE EXPANSION CLOVIS UNIFIED SCHOOL DISTRICT CLOVIS, CA DRAWING TITLE FINISH FLOOR PLAN - BLDG B - SPECIAL EDUCATION ADMIN

PROJECT NO. 12242.00 DRAWING NO. A940

\\netfiles1\Users\Elizabeth.Conti_TETRI\Documents\12242-A-DO_SITE_aliz.conteras.rvt

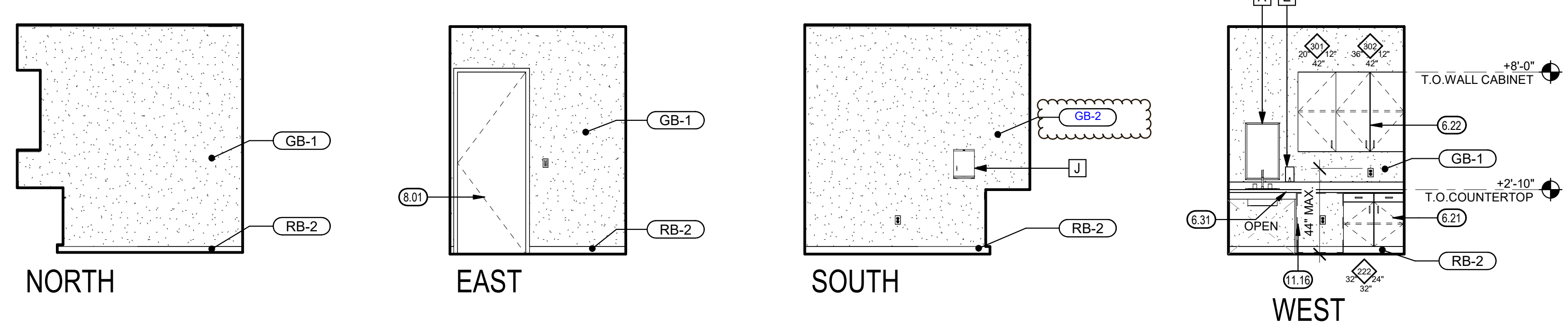

LACTATION - B02 1/4" = 1'-0" 6

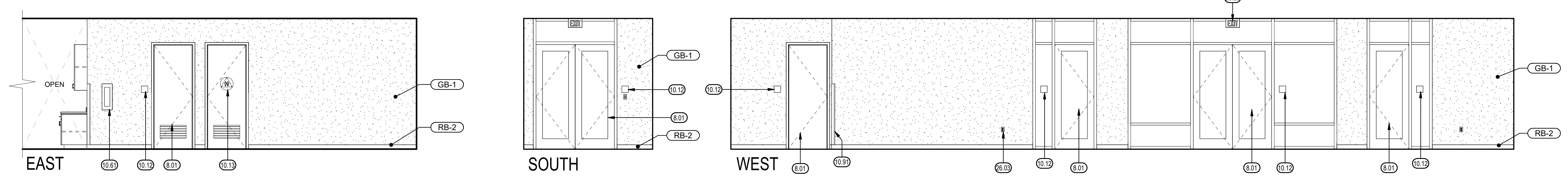

CITI KIDS CORRIDOR - B03 1/4" = 1'-0" 7

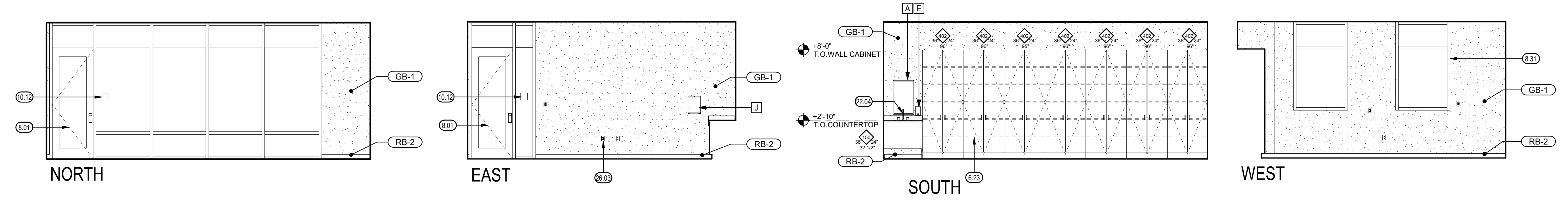

ASSESSMENT - B04 1/4" = 1'-0" 8

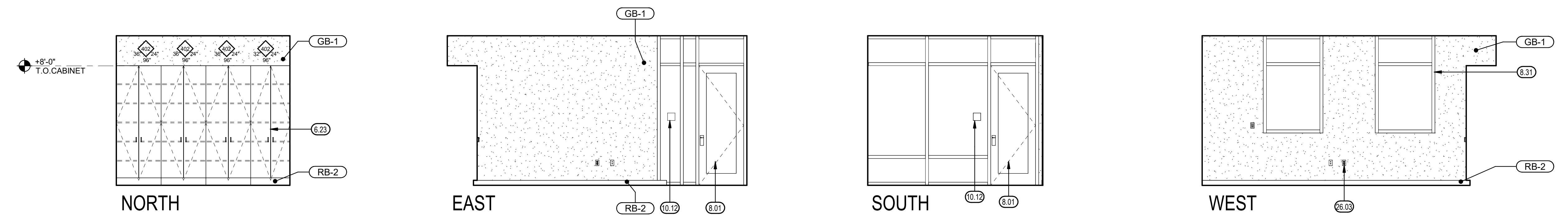

ASSESSMENT - B06 1/4" = 1'-0" 9

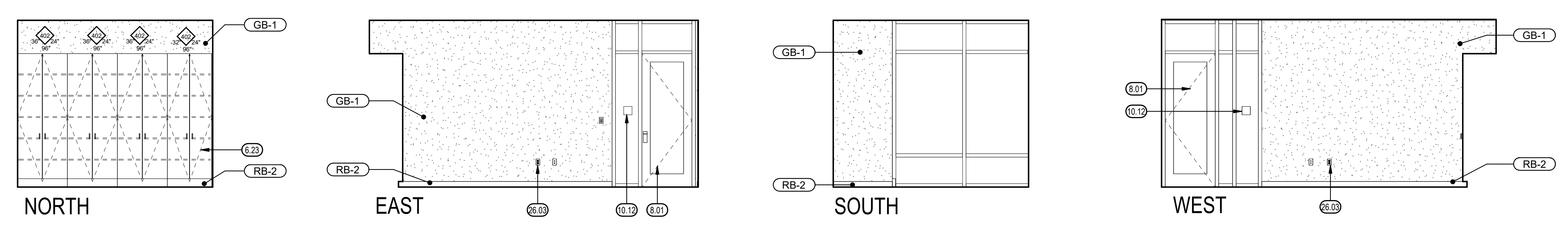

ASSESSMENT - B07 1/4" = 1'-0" 10

KEYNOTES 00.00

- 6.21 PLASTIC LAMINATE BASE CABINET
- 6.22 PLASTIC LAMINATE UPPER CABINET
- 6.23 PLASTIC LAMINATE TALL STORAGE CABINET, SEE DETAIL 3 / A861
- 6.31 ACCESSIBLE SINK AND CABINET, SEE DETAIL 13 / A800
- 8.01 DOOR AND FRAME AS SCHEDULED
- 8.31 WINDOW AND FRAME AS SCHEDULED
- 10.12 ROOM IDENTIFICATION SIGNAGE, TYP. SEE DETAIL 3 / A801
- 10.13 TOILET ROOM GEOMETRIC SYMBOLS, SEE DETAIL 6 / A801
- 10.61 FIRE EXTINGUISHER CABINET AND FIRE EXTINGUISHER
- 10.91 CORNER GUARD, TYP. SEE DETAIL 6 / A860
- 11.16 UNDER COUNTER FRIDGE, OFOI, SEE ELECTRICAL
- 22.04 PLUMBING FIXTURE, SEE PLUMBING
- 26.03 WALL OUTLET, SEE ELECTRICAL, TYP.
- 26.25 EXIT SIGN, SEE ELECTRICAL

IDENTIFICATION STAMP
 DIV. OF THE STATE ARCHITECT
 APP: 02-121813 INC.
 REVIEWED FOR
 SS FLS ACS
 DATE: 09/28/2023

I, the undersigned, hereby certify that I am the author of the drawings and specifications herein, and that I am a duly licensed and qualified professional architect in the State of California. My registration number is 12345.

MARK	DATE	DESCRIPTION
	7/17/23	DSA BACKCHECK



TETER, INC.
 ARCHITECTS ENGINEERS CONNECTED
 VISALIA, CALIFORNIA

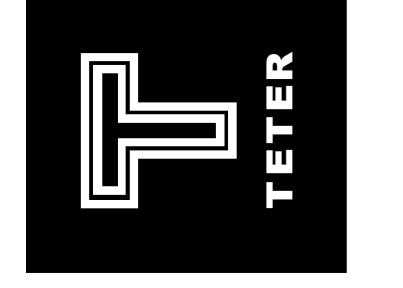

TOILET ACCESSORY SCHEDULE

MARK	DESCRIPTION	MFR.	MODEL NO.	REMARKS
A	MIRROR (18" X 30")	BOBRICK	B-165	SURFACE MTD.
B	TOILET TISSUE DISPENSER	BRADLEY	5241	SURFACE / PARTITION MTD.
C	MOP HOLDER	BOBRICK	B-223x24	SURFACE MTD.
D	ELECTRIC HAND DRYER	EXCEL DRYER INC.	XLERATOR	SURFACED MTD.
E	SOAP DISPENSER (O.F.C.I.)	IMPACT PRODUCTS	9326 FOAMEEZE	SURFACED MTD.
F	SANITARY NAPKIN DISPENSER	BOBRICK	B-2706 25	SURFACE MTD.
G	SANITARY NAPKIN DISPOSAL UNIT	BOBRICK	B-270	SURFACE MTD. / PARTITION MTD.
H	TOILET SEAT COVER DISPENSER	BOBRICK	B-221	SURFACE MTD.
J	PAPER TOWEL DISPENSER (O.F.C.I.)	GP PRO UNIVERSAL	54338A	SURFACE MTD.
K	GRAB BAR, SIDE	BOBRICK	B-6806 SERIES	48" LONG
L	GRAB BAR, REAR	BOBRICK	B-6806 SERIES	42" LONG
M	GRAB BAR, REAR	BOBRICK	B-6806 SERIES	30" LONG

GENERAL NOTES

- A. PROVIDE BLOCKING FOR ALL WALL MOUNTED ACCESSORIES AND EQUIPMENT, TYP. SEE 1 / A860
- B. FOR ACCESSIBLE FIXTURE AND ACCESSORY MOUNTING HEIGHTS AND CLEARANCES, SEE 12 / A800, 3 / A800, AND 13 / A800
- C. FOR TYPICAL CASEWORK ANCHORAGE SEE 2 / A861
- D. FOR GRAB BAR ANCHORAGE SEE 9 / A800 AND 10 / A800
- E. FOR MIRROR ANCHORAGE SEE 19 / A800 AND 20 / A800
- F. SEE INTERIOR FINISH SCHEDULE A900 AND A940 FOR ADDITIONAL INFORMATION.

KEY PLAN

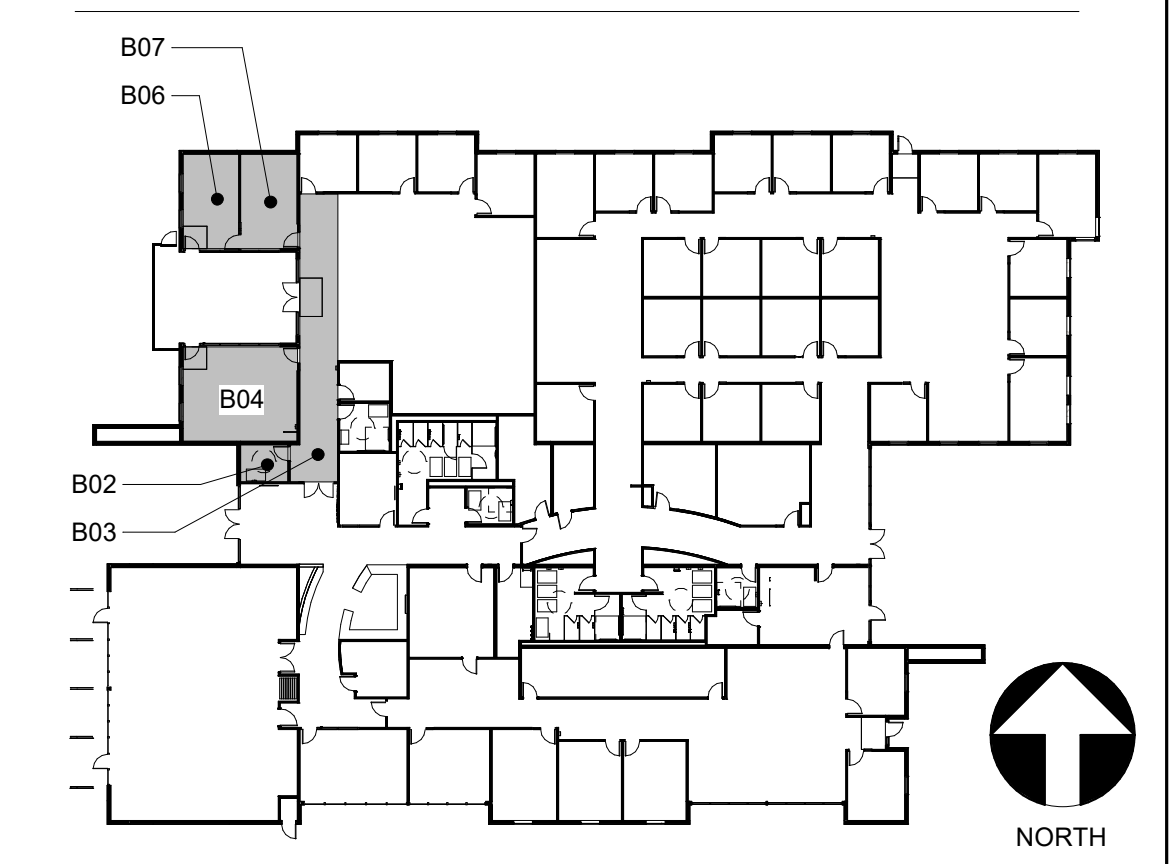

ONLINE SCHOOL & SPECIAL EDUCATION
 ADMINISTRATION DISTRICT OFFICE EXPANSION
 CLOVIS UNIFIED SCHOOL DISTRICT
 CLOVIS, CA
 DRAWING TITLE
 INTERIOR ELEVATIONS - BLDG B - SPECIAL EDUCATION ADMIN

PROJECT NO.
 12242.00
 DRAWING
A951

PLOT DATE: 9/13/2023 2:10:32 PM

\\net-files\1\Users\Elizabeth.Conti_TETRI\Documents\12242-A-DO_SITE_aliz.conteras.rvt

PLOT DATE: 9/13/2023 2:16:30 PM

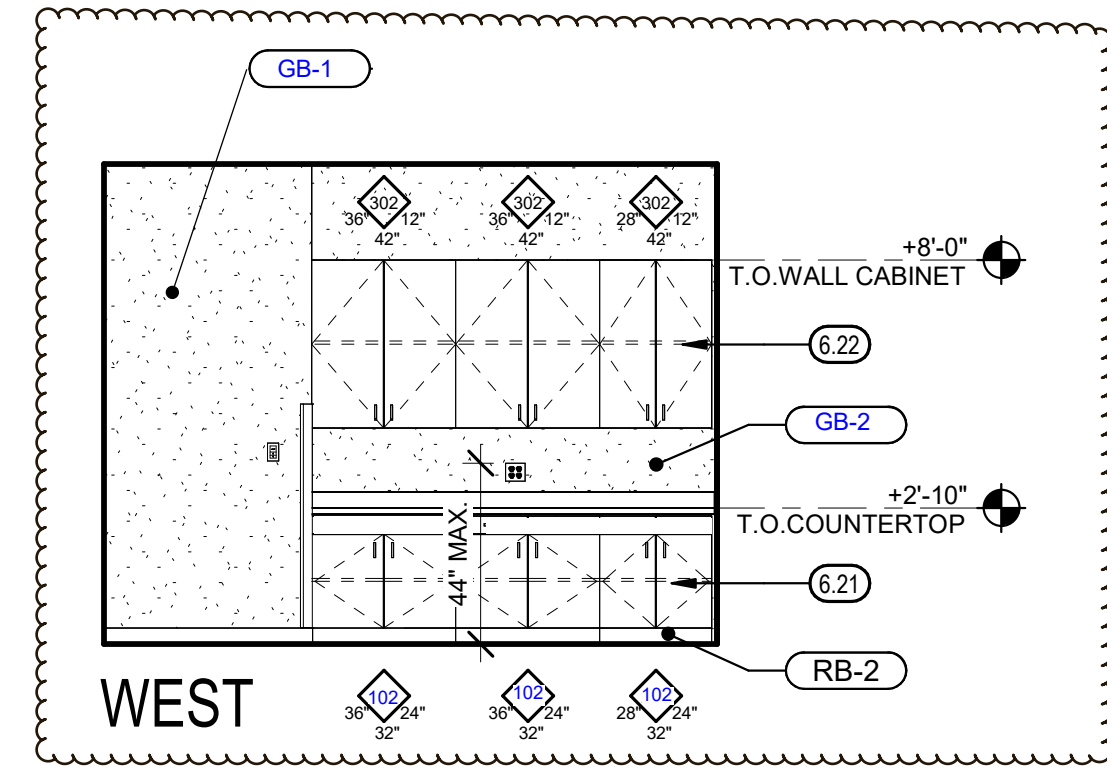
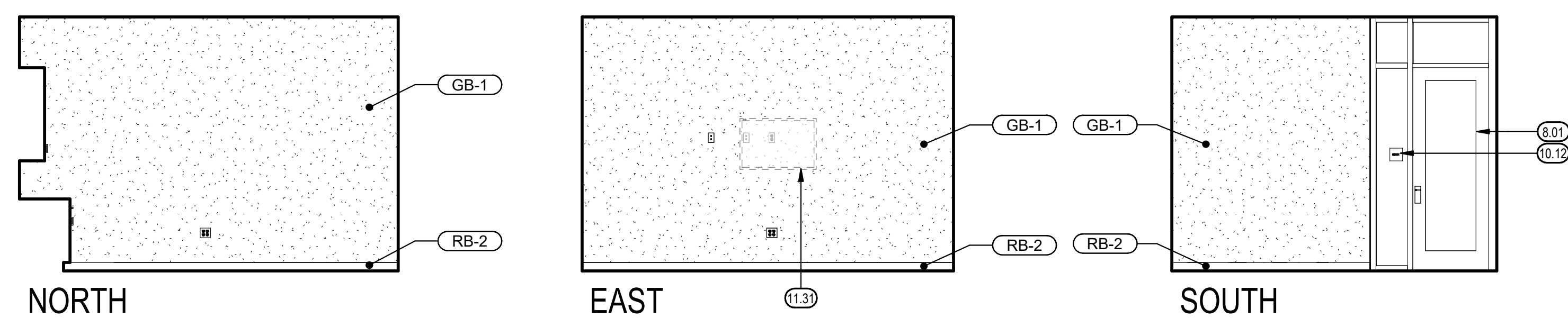

SMALL CONFERENCE - B50

1/4" = 1'-0" 6

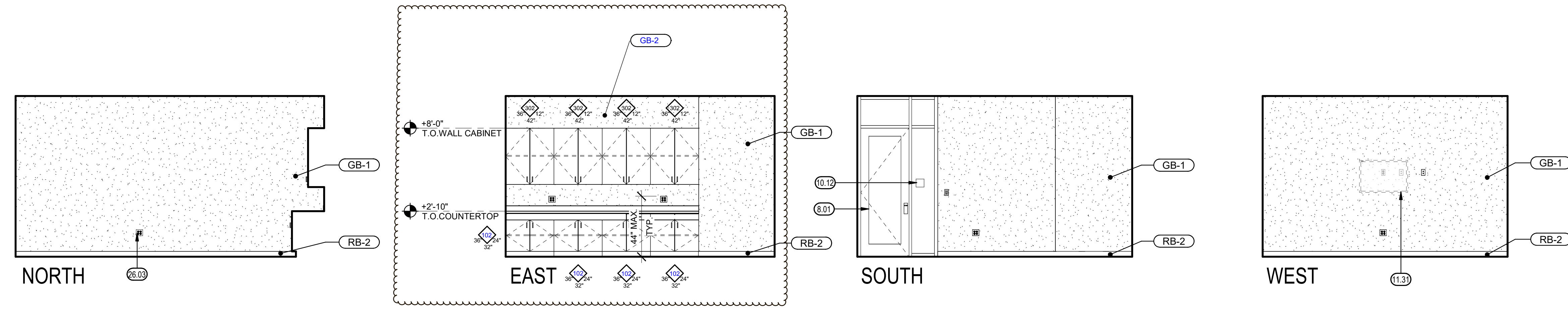

MEDIUM CONFERENCE - B51

1/4" = 1'-0" 7

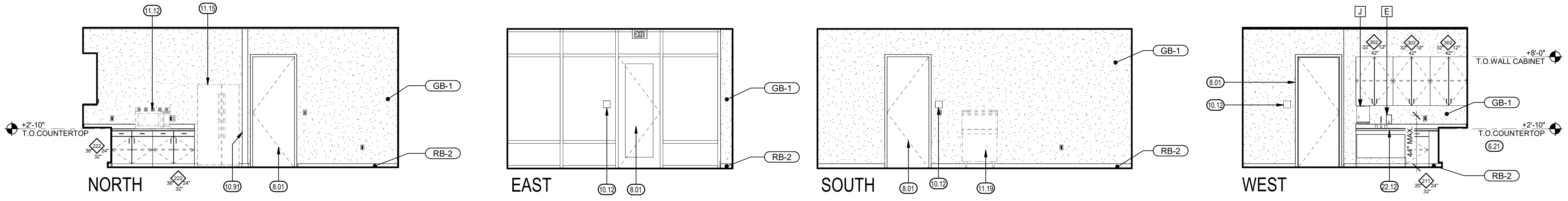

BREAK ROOM - B52

1/4" = 1'-0" 8

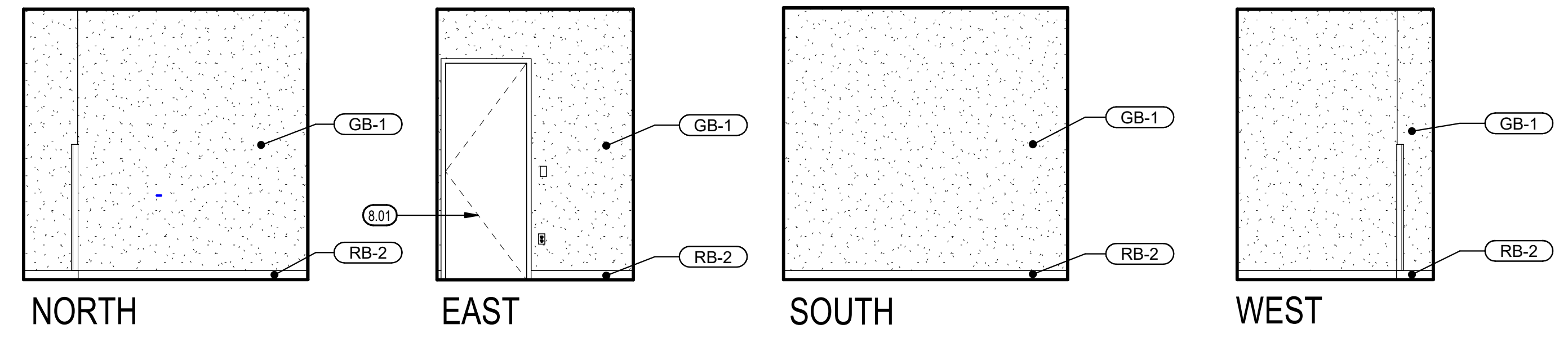

STORAGE - B53

1/4" = 1'-0" 19

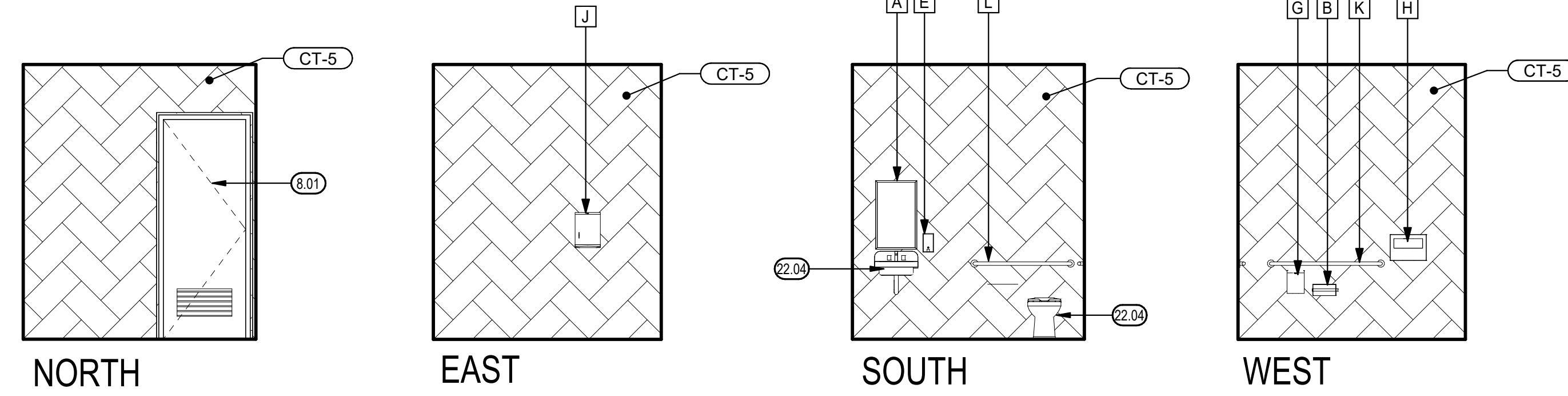

UNISEX - B54

1/4" = 1'-0" 9

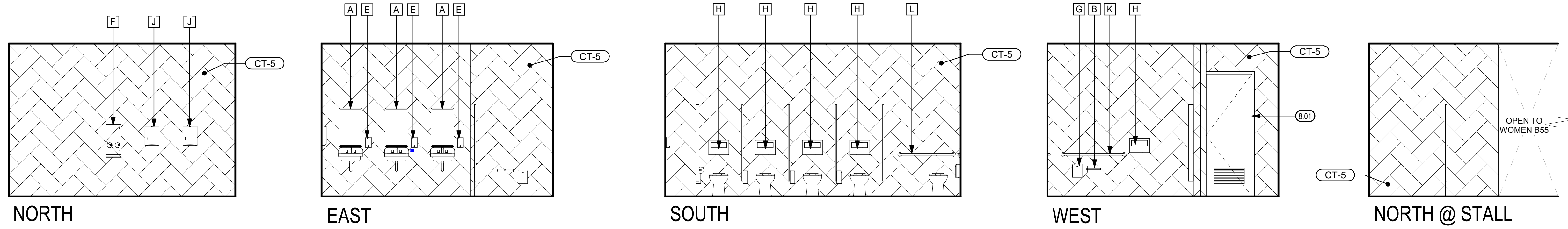

WOMEN - B55

1/4" = 1'-0" 10

KEYNOTES (0.0)

- 6.21 PLASTIC LAMINATE BASE CABINET
- 6.22 PLASTIC LAMINATE UPPER CABINET
- 8.01 DOOR AND FRAME AS SCHEDULED
- 10.12 ROOM IDENTIFICATION SIGNAGE, TYP. SEE DETAIL 3 / A801
- 10.91 CORNER GUARD, TYP. SEE DETAIL 6 / A860
- 11.12 MICROWAVE OVEN, OFOI
- 11.15 REFRIGERATOR, OFOI. SEE PLUMBING & ELECTRICAL
- 11.19 ICE MACHINE, OFOI. SEE PLUMBING & ELECTRICAL
- 11.31 PROVIDE BACKING FOR OFOI MONITOR, SEE DETAILS 1/A860, 3/A860, 8/A860, & 12/A860
- 22.04 PLUMBING FIXTURE. SEE PLUMBING
- 22.12 SINK WITH GARBAGE DISPOSAL
- 26.03 WALL OUTLET, SEE ELECTRICAL, TYP.
- 26.25 EXIT SIGN, SEE ELECTRICAL

IDENTIFICATION STAMP
 DIV. OF THE STATE ARCHITECT
 APP: 02-121813 INC.
 REVIEWED FOR: []
 DATE: 09/28/2023

MARK	DATE	DESCRIPTION	DSR
	7/17/23	DSA BACKCHECK	



TOILET ACCESSORY SCHEDULE

MARK	DESCRIPTION	MFR.	MODEL NO.	REMARKS
A	MIRROR (18" X 30")	BOBRICK	B-165	SURFACE MTD.
B	TOILET TISSUE DISPENSER	BRADLEY	5241	SURFACE / PARTITION MTD.
C	MOP HOLDER	BOBRICK	B-223x24	SURFACE MTD.
D	ELECTRIC HAND DRYER	EXCEL DRYER INC.	XLERATOR	SURFACED MTD.
E	SOAP DISPENSER (O.F.C.I.)	IMPACT PRODUCTS	9326 FOAMEEZE	SURFACED MTD.
F	SANITARY NAPKIN DISPENSER	BOBRICK	B-2706 25	SURFACE MTD.
G	SANITARY NAPKIN DISPOSAL UNIT	BOBRICK	B-270	SURFACE MTD./PARTITION MTD.
H	TOILET SEAT COVER DISPENSER	BOBRICK	B-221	SURFACE MTD.
J	PAPER TOWEL DISPENSER (O.F.C.I.)	GP PRO UNIVERSAL	54338A	SURFACE MTD.
K	GRAB BAR, SIDE	BOBRICK	B-6806 SERIES	48" LONG
L	GRAB BAR, REAR	BOBRICK	B-6806 SERIES	42" LONG
M	GRAB BAR, REAR	BOBRICK	B-6806 SERIES	30" LONG

GENERAL NOTES

- A. PROVIDE BLOCKING FOR ALL WALL MOUNTED ACCESSORIES AND EQUIPMENT, TYP. SEE 1 / A800
- B. FOR ACCESSIBLE FIXTURE AND ACCESSORY MOUNTING HEIGHTS AND CLEARANCES, SEE 12 / A800, 3 / A800, AND 13 / A800
- C. FOR TYPICAL CASEWORK ANCHORAGE SEE 2 / A861
- D. FOR GRAB BAR ANCHORAGE SEE 9 / A800 AND 10 / A800
- E. FOR MIRROR ANCHORAGE SEE 19 / A800 AND 20 / A800
- F. SEE INTERIOR FINISH SCHEDULE A900 AND A940 FOR ADDITIONAL INFORMATION.

KEY PLAN

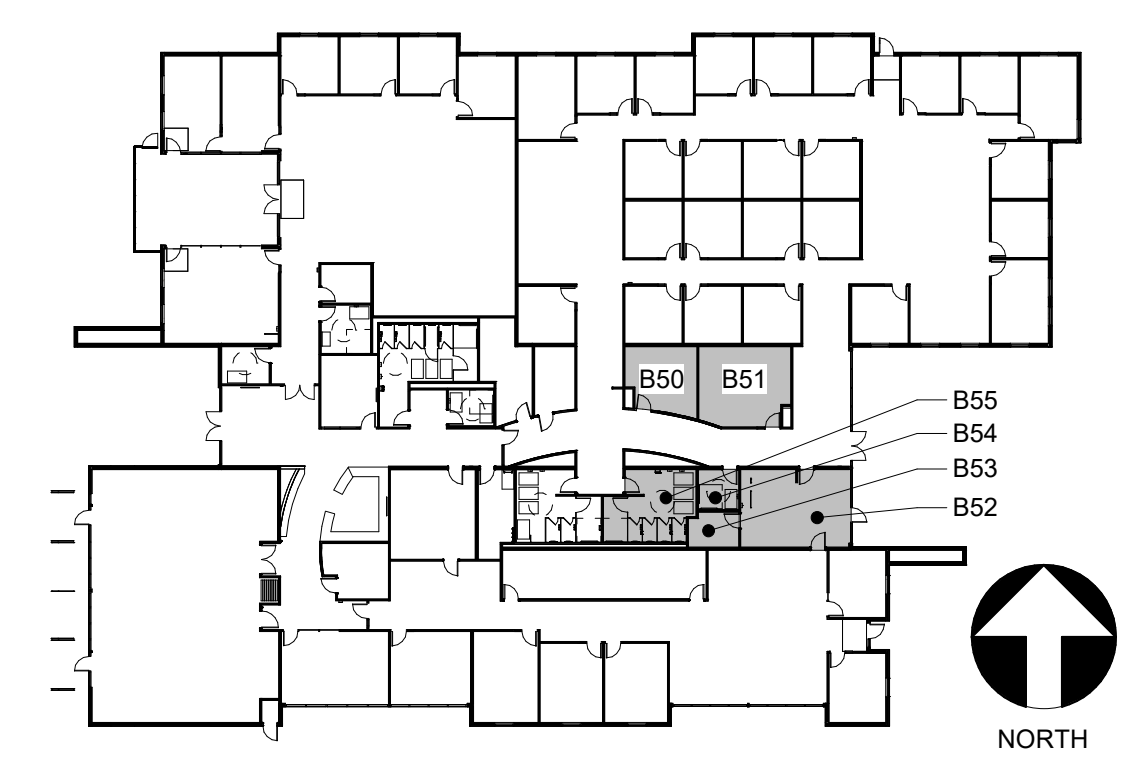

TETER, INC.
 FRESNO HEADQUARTERS
 VISUAL ENGINEERING | MODERNO | SAN LUIS OBISPO
 ARCHITECTS ENGINEERS CONNECTED

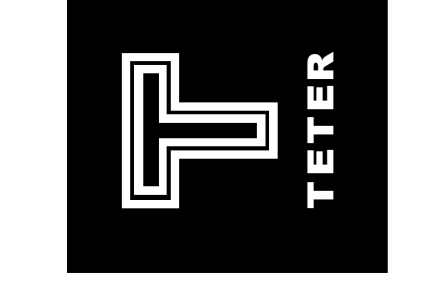

ONLINE SCHOOL & SPECIAL EDUCATION ADMINISTRATION DISTRICT OFFICE EXPANSION
 CLOVIS UNIFIED SCHOOL DISTRICT
 CLOVIS, CA
 DRAWING TITLE
 INTERIOR ELEVATIONS - BLDG B - SPECIAL EDUCATION ADMIN

PROJECT NO.
 12242.00
 DRAWING
A956

\\net-files\1\Users\Elizabeth.Conti_TETRI\Documents\12242-A-DO_SITE_aliz.conteras.rvt

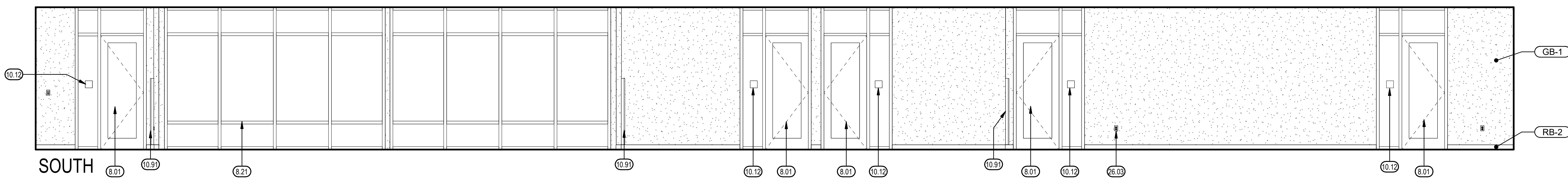
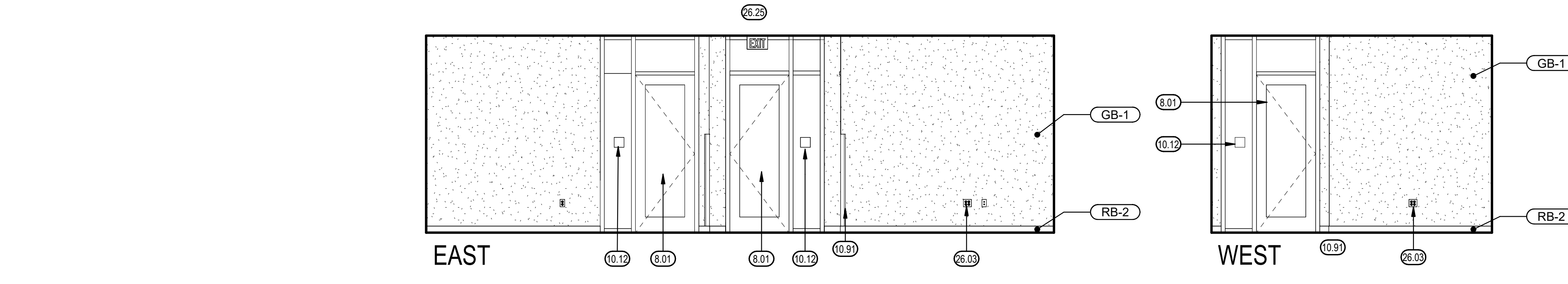
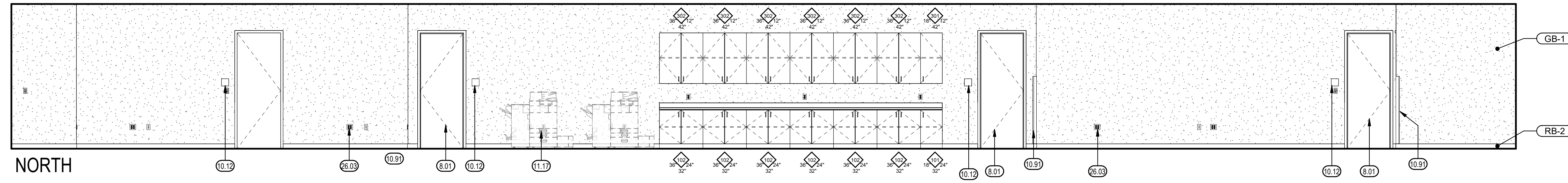

ADMIN CORRIDOR - B70

1/4" = 1'-0" 8

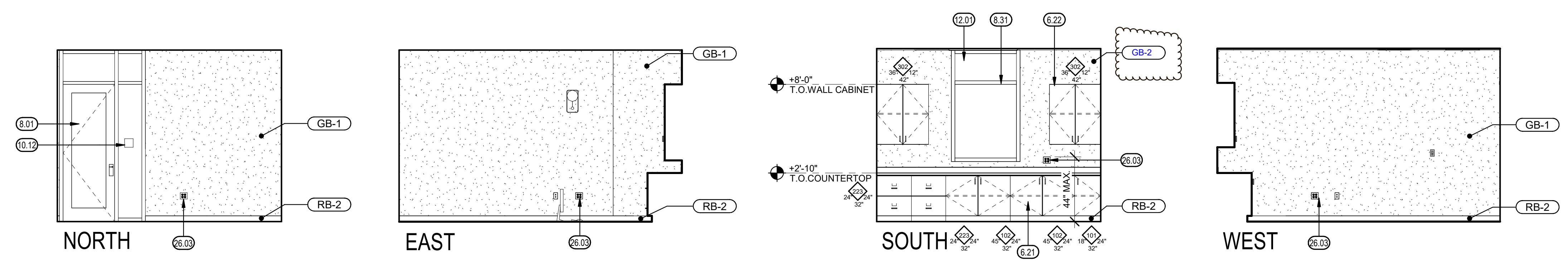

ADMIN. OFFICE - B71

1/4" = 1'-0" 9

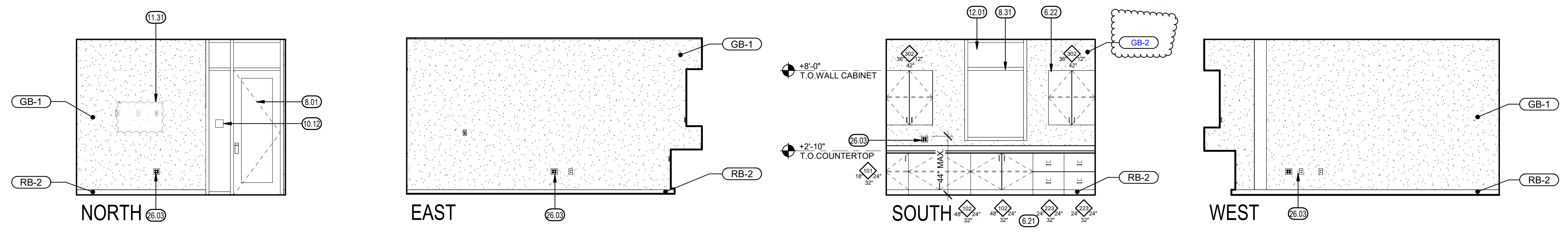

ADMIN. OFFICE - B73

1/4" = 1'-0" 10

KEYNOTES

- 6.21 PLASTIC LAMINATE BASE CABINET
- 6.22 PLASTIC LAMINATE UPPER CABINET
- 8.01 DOOR AND FRAME AS SCHEDULED
- 8.21 ALUMINUM STOREFRONT
- 8.31 WINDOW AND FRAME AS SCHEDULED
- 10.12 ROOM IDENTIFICATION SIGNAGE, TYP. SEE DETAIL 3 / A801
- 10.91 CORNER GUARD, TYP. SEE DETAIL 6 / A860
- 11.17 PRINTER, OFOI
- 11.31 PROVIDE BACKING FOR OFOI MONITOR, SEE DETAILS 1/A860, 3/A860, 8/A860, & 12/A860
- 12.01 NOT USED
- 26.03 WALL OUTLET, SEE ELECTRICAL, TYP.
- 26.25 EXIT SIGN, SEE ELECTRICAL.

IDENTIFICATION STAMP
 DIV. OF THE STATE ARCHITECT
 APP: 02-121813 INC.
 REVIEWED FOR
 SS FLS ACS
 DATE: 09/28/2023

For the use, reproduction, or distribution of this document, the user must obtain the written consent of the architect. This consent shall be in writing and shall be on the architect's letterhead.

MARK	DATE	DESCRIPTION
	7/17/23	DSA BACKCHECK



TETER, INC.
 PRESNO HEADQUARTERS
 VISALIA | BANGORFIELD | WOODSTOCK | SAN LUIS OBISPO
 ARCHITECTS ENGINEERS CONNECTED

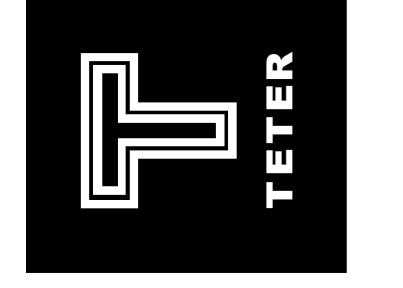

GENERAL NOTES

- A. PROVIDE BLOCKING FOR ALL WALL MOUNTED ACCESSORIES AND EQUIPMENT, TYP. SEE 1 / A860
- B. FOR ACCESSIBLE FIXTURE AND ACCESSORY MOUNTING HEIGHTS AND CLEARANCES, SEE 12 / A800, 3 / A800, AND 13 / A800
- C. FOR TYPICAL CASEWORK ANCHORAGE SEE 2 / A861
- D. FOR GRAB BAR ANCHORAGE SEE 9 / A800 AND 10 / A800
- E. FOR MIRROR ANCHORAGE SEE 19 / A800 AND 20 / A800
- F. SEE INTERIOR FINISH SCHEDULE A900 AND A940 FOR ADDITIONAL INFORMATION.

KEY PLAN

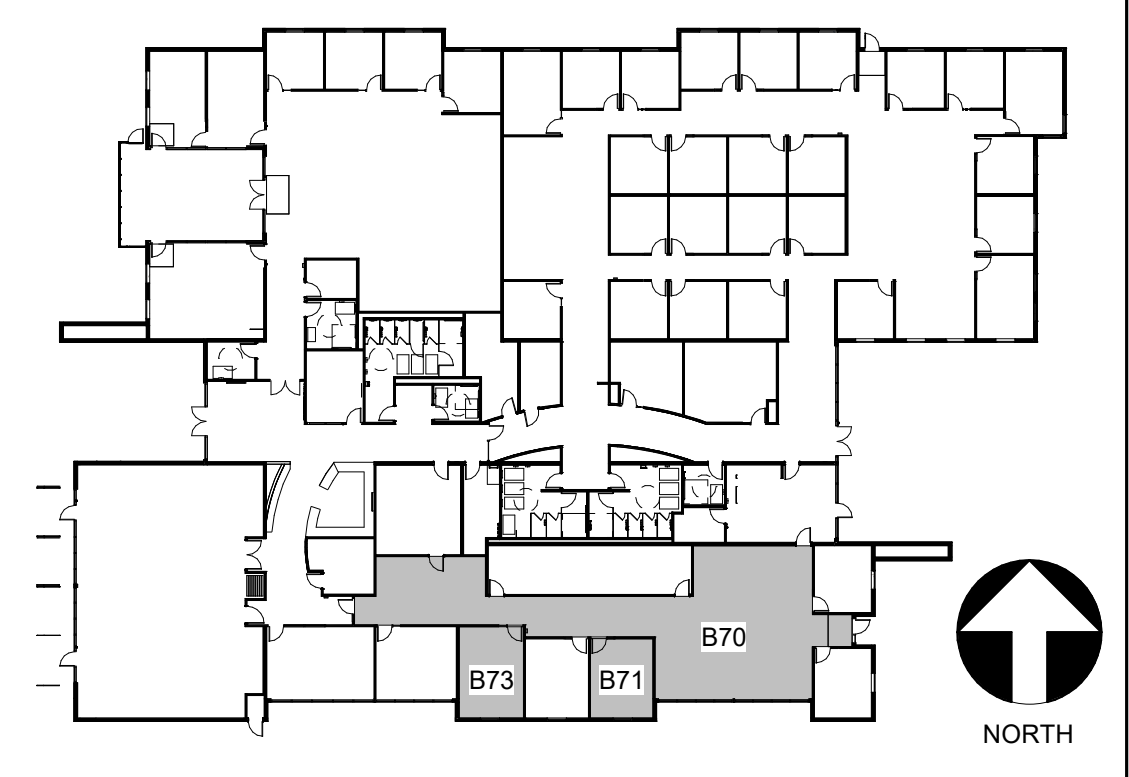

ONLINE SCHOOL & SPECIAL EDUCATION
 ADMINISTRATION DISTRICT OFFICE EXPANSION
 CLOVIS UNIFIED SCHOOL DISTRICT
 CLOVIS, CA
 DRAWING TITLE
 INTERIOR ELEVATIONS - BLDG B - SPECIAL EDUCATION ADMIN

PROJECT NO.
 12242.00
 DRAWING
A959

PLOT DATE: 9/13/2023 2:19:49 PM

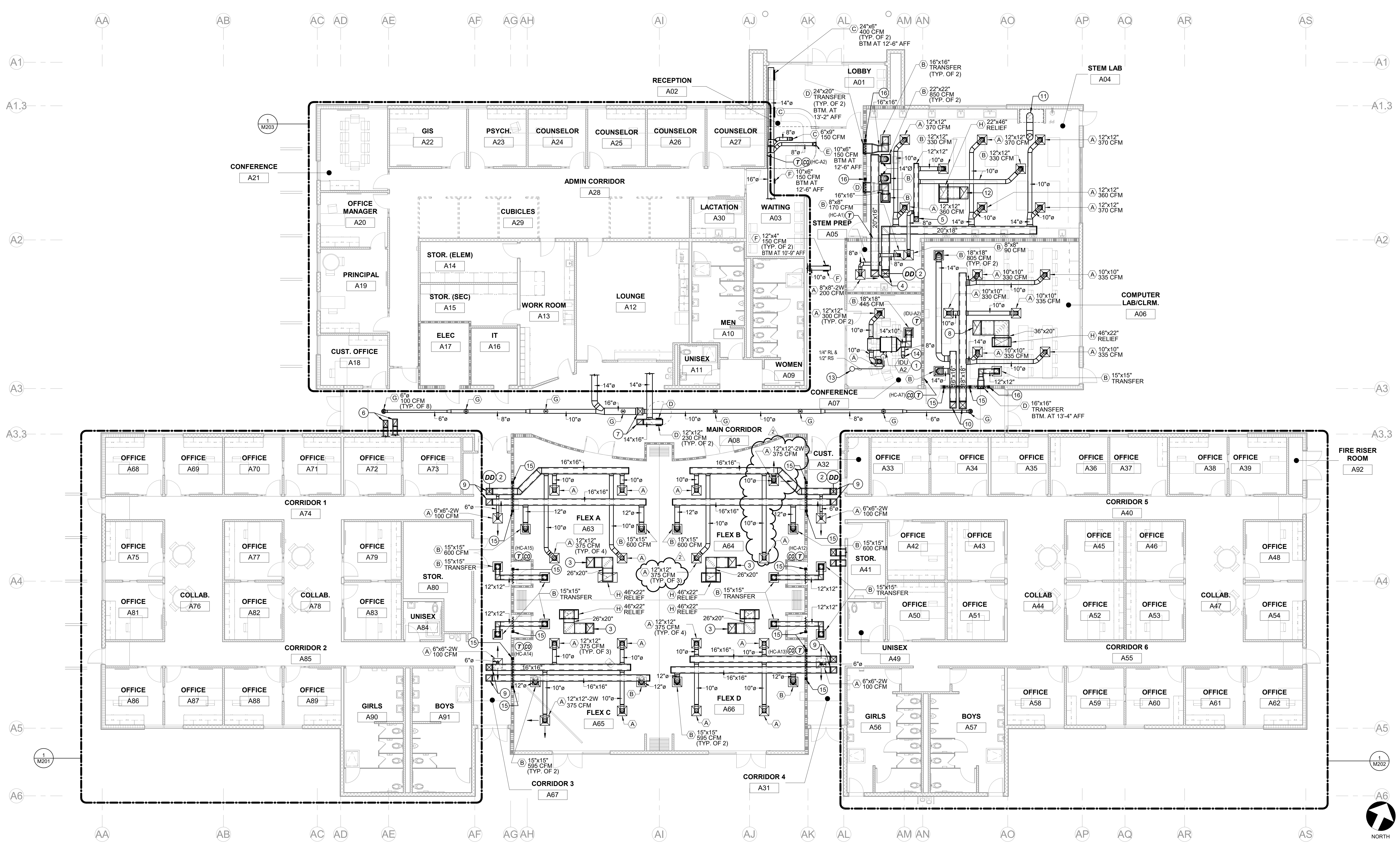

MECHANICAL FLOOR PLAN - BUILDING A

1/8" = 1'-0" 1

KEYNOTES

- 1 DUCTED INDOOR UNIT SUSPENDED FROM STRUCTURE ABOVE. SEE 16/M800 FOR SUPPORT.
- 2 INSTALL DUCT SMOKE DETECTOR IN SA DUCT DROP. SEE 23/M800 FOR DETAIL.
- 3 26"x20" DUCT UP TO RELIEF HOOD ON ROOF. SEE M500 FOR CONT.
- 4 20"x18" SA & 20"x16" RA DUCTS UP TO PACKAGE UNIT ON ROOF. SEE M500 FOR CONT.
- 5 12"x12" EA DUCT UP TO EXHAUST FAN ON ROOF. SEE M500 FOR CONT.
- 6 12"x18" SA & 12"x18" RA DUCTS UP TO PACKAGE UNIT ON ROOF. SEE M500 FOR CONT.
- 7 18"x14" SA & 16"x14" RA DUCTS UP TO PACKAGE UNIT ON ROOF. SEE M500 FOR CONT.
- 8 36"x20" DUCT UP TO RELIEF HOOD ON ROOF. SEE M500 FOR CONT.
- 9 16"x16" SA & 16"x16" RA DUCTS UP TO PACKAGE UNIT ON ROOF. SEE M500 FOR CONT.
- 10 18"x18" SA & 16"x16" RA DUCTS UP TO PACKAGE UNIT ON ROOF. SEE M500 FOR CONT.

- 11 CONNECT 16"Ø STAINLESS STEEL EA DUCT TO FUME HOOD AND ROUTE UP THRU ROOF TO EXHAUST FAN. SEE M500 FOR CONT.
- 12 30"x20" DUCT UP TO RELIEF HOOD ON ROOF. SEE M500 FOR CONT.
- 13 1/4" RL & 1/2" RS UP TO ODU ON ROOF. SEE M500 FOR CONT.
- 14 8"Ø OSA DUCT UP TO INTAKE VENT ON ROOF. SEE M500 FOR CONT.
- 15 INSTALL FIRE/SMOKE DAMPER IN DUCT. SEE 19/M800 FOR DETAIL.
- 16 INSTALL FIRE/SMOKE DAMPER AT SIDEWALL GRILLE. SEE 27/M800 FOR DETAIL.

GENERAL NOTES

- A. SEE DETAIL 11,13&24/M800 FOR TYPICAL CEILING GRILLE.
- B. SEE DETAIL DETAILS 12&13/M800 FOR TYPICAL DUCT SUPPORTS.
- C. SEE DETAIL 21/M800 FOR TYPICAL DUCT BRANCH DETAILS.
- D. REFRIGERANT RL&RS PIPING SHOWN AS SINGLE LINE FOR CLARITY. SEE DETAIL 17/M800 FOR TYPICAL REFRIGERANT PIPE SUPPORTS.
- E. MOUNT THERMOSTATS AT +48" AFF TO TOP OF BOX.
- F. DUCT SIZES SHOWN ARE INSIDE CLEAR DIMENSIONS. WHERE INTERNAL LINING IS SHOWN OR SPECIFIED, INCREASE FABRICATED DUCT DIMENSIONS TO ACCOMMODATE.

MARK	DATE	DESCRIPTION	DSA BACKCHECK
2	10/24/23	FLEX ROOM B GRILLE RELOCATION	

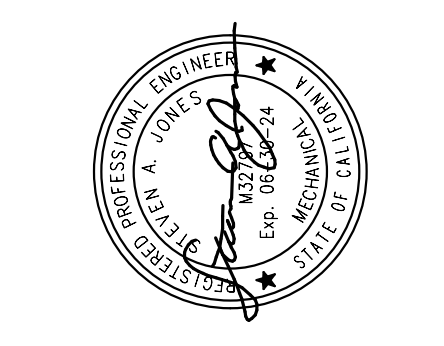

TETER, LLP
 FRESNO HEADQUARTERS
 VISUAL | BAKERSFIELD | MADERA | SAN LUIS OBISPO
 ARCHITECTS ENGINEERS CONNECTED

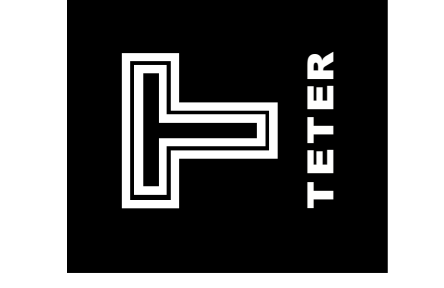

ONLINE SCHOOL & SPECIAL EDUCATION
 ADMINISTRATION DISTRICT OFFICE EXPANSION
 CLOVIS UNIFIED SCHOOL DISTRICT
 CLOVIS, CA
 DRAWING TITLE
 OVERALL MECHANICAL FLOOR PLAN - BUILDING A

PROJECT NO.
 12242.00
 DRAWING
M200

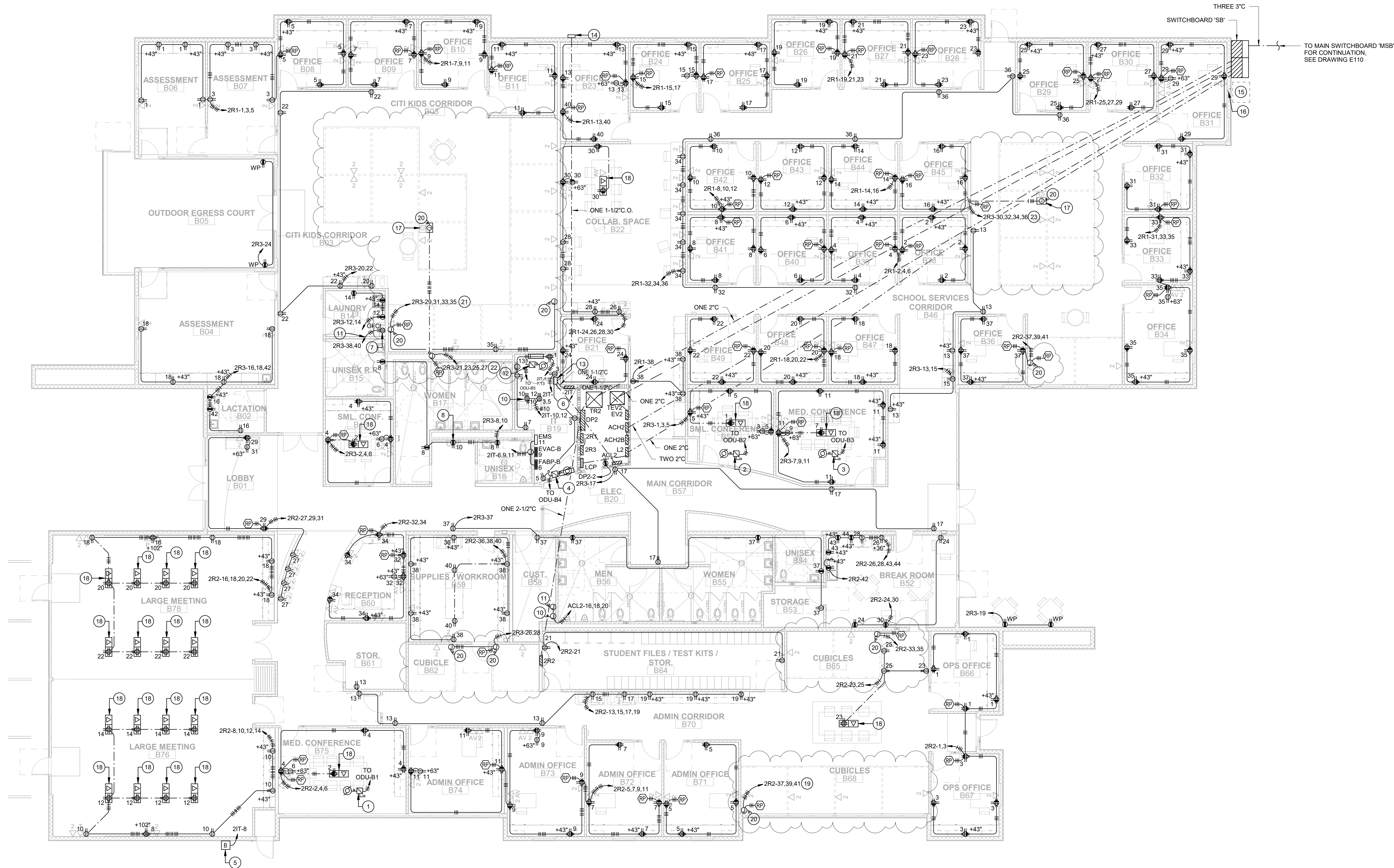

POWER PLAN - BUILDING B

1/8" = 1'-0" 1

KEYNOTES

- 1 PROVIDE 250V, 30A, 3-POLE GENERAL DUTY FUSED DISCONNECT WITH 15A FUSES. PROVIDE CONNECTION FOR 208V, 1φ, 2.73 MCA, INDOOR UNIT 'IDU-B1' VIA OUTDOOR UNIT 'ODU-B1'.
- 2 PROVIDE 250V, 30A, 3-POLE GENERAL DUTY FUSED DISCONNECT WITH 15A FUSES. PROVIDE CONNECTION FOR 208V, 1φ, 1.69 MCA, INDOOR UNIT 'IDU-B2' VIA OUTDOOR UNIT 'ODU-B2'.
- 3 PROVIDE 250V, 30A, 3-POLE GENERAL DUTY FUSED DISCONNECT WITH 15A FUSES. PROVIDE CONNECTION FOR 208V, 1φ, 1.69 MCA, INDOOR UNIT 'IDU-B3' VIA OUTDOOR UNIT 'ODU-B3'.
- 4 PROVIDE 250V, 30A, 3-POLE GENERAL DUTY FUSED DISCONNECT WITH 15A FUSES. PROVIDE CONNECTION FOR 208V, 1φ, 1.0 MCA, INDOOR UNIT 'IDU-B4' VIA OUTDOOR UNIT 'ODU-B4'.
- 5 PROVIDE 120V POWER CONNECTION TO FIRE SPRINKLER ELECTRIC BELL, THRU WATER FLOW SWITCH ON FIRE SPRINKLER RISER.
- 6 PROVIDE A CIRCUIT BREAKER LOCKING DEVICE ON EACH CIRCUIT BREAKER SUPPLYING FIRE ALARM SYSTEM EQUIPMENT AND PROVIDE A RED LABEL THAT READS: "FIRE ALARM / ECS" ADJACENT TO THE CIRCUIT BREAKER.
- 7 NEMA 14-30R, 125/250V, 30A, 3-POLE, 4-WIRE GROUNDING TYPE ELECTRIC DRYER RECEPTACLE. PROVIDE 30A, 250V, GROUND-FAULT CIRCUIT INTERRUPTER PROTECTIVE DEVICE AT OUTLET.
- 8 120V, 20A, DUPLEX GFCI TYPE RECEPTACLE MOUNTED WITHIN ELECTRIC DRINKING FOUNTAIN ENCLOSURE PER MANUFACTURER'S INSTALLATION INSTRUCTIONS.
- 9 PROVIDE ONE 1" CW WITH 2#10 CU THWN AND #10 CU GND FOR IRRIGATION CONTROLLER.
- 10 PROVIDE ONE 30A, 120V, 2-POLE, 3-WIRE GROUNDING TYPE NEMA L5-30R RECEPTACLES ABOVE EACH TELECOMMUNICATION RACK.
- 11 ONE 3/4" CW, #10 CU THWN, #10 CU GND.
- 12 PROVIDE 250V, 30A, 3-POLE GENERAL DUTY FUSED DISCONNECT WITH 15A FUSES. PROVIDE CONNECTION FOR 208V, 1φ, 1.0 MCA, INDOOR UNIT 'IDU-B5' VIA OUTDOOR UNIT 'ODU-B5'.
- 13 PROVIDE 14.5"W x 28"H x 8.5"D PULLCAN.
- 14 PROVIDE 12"x12"x6" PULLCAN AT 12" A.F.G. TO BOTTOM OF PULLCAN.
- 15 FUTURE LOCATION OF SOLAR READY INVERTERS AND PANELS.
- 16 FUTURE LOCATION OF SOLAR READY CONDUIT.
- 17 PROVIDE LEGRAND #RFB6 SERIES FURNITURE FEED FLOOR BOX WITH FURNITURE FEED COVER.
- 18 PROVIDE LEGRAND #RFB6 SERIES FLOORBOX.
- 19 PROVIDE HANDLE TIE FOR CIRCUITS WITH SHARED NEUTRAL, CIRCUITS 2R2-38,41.
- 20 PROVIDE FLEXIBLE POWER CONNECTION TO MODULAR FURNITURE.
- 21 PROVIDE HANDLE TIE FOR CIRCUITS WITH SHARED NEUTRAL, CIRCUITS 2R3-31,33,35.
- 22 PROVIDE HANDLE TIE FOR CIRCUITS WITH SHARED NEUTRAL, CIRCUITS 2R3-23,25,27.
- 23 PROVIDE HANDLE TIE FOR CIRCUITS WITH SHARED NEUTRAL, CIRCUITS 2R3-32,34,36.

GENERAL NOTES

- A. PROVIDE ELECTRICAL FEEDERS PER SINGLE LINE DIAGRAM.
- B. CONDUIT AND CONDUCTORS SHALL BE CONCEALED, U.O.N.
- C. PENETRATIONS THROUGH WALLS, CEILINGS, FLOORS, AND/OR ROOFS SHALL BE SEALED.
- D. ALL 120V, 15A AND 20A RECEPTACLES WITHIN KITCHENS AND RESTROOMS SHALL BE GFCI TYPE RECEPTACLES. IN ALL OTHER SPACES, 120V, 15A AND 20A RECEPTACLES WITHIN 6' OF SINKS OR FAUCETS SHALL BE GFCI TYPE RECEPTACLES.
- E. SEAL PENETRATIONS THROUGH FIRE RATED ASSEMBLIES PER 23/E600.

ONLINE SCHOOL & SPECIAL EDUCATION ADMINISTRATION DISTRICT OFFICE EXPANSION CLOVIS UNIFIED SCHOOL DISTRICT CLOVIS, CA

PROJECT NO. 12242.00 DRAWING E220

TETER, INC. FRESNO HEADQUARTERS VISALIA BRANISFIELD WOODS RD VISALIA, CA ARCHITECTS ENGINEERS CONNECTED

MARK	DATE	DESCRIPTION	DSA BACKCHECK
2	10/25/23	ADDENDUM #5	
	9/21/23		

7/20/2023

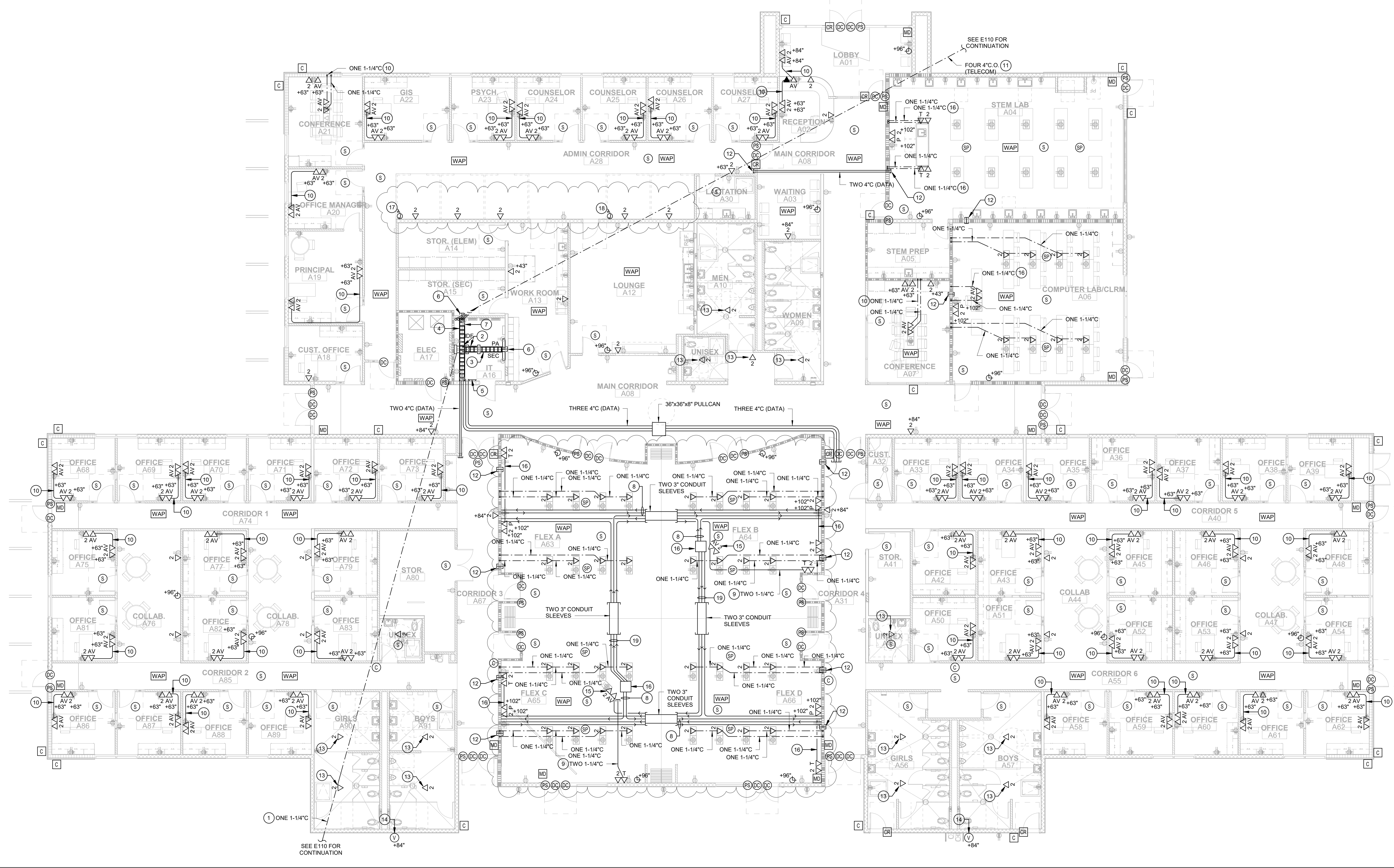

SIGNAL PLAN - BUILDING A

1/8" = 1'-0" 1

KEYNOTES

- 1 PROVIDE ONE 1-1/4" WITH ONE TYPE 'DX' CABLE FOR IRRIGATION CONTROLLER.
- 2 IDF: PROVIDE TWO 7' TALL, 19" EIA STANDARD TWO-POST RACKS, BLACK IN COLOR. CHATSWORTH PRODUCTS, INC. MODEL 55093-703. PROVIDE 6" VELOCITY VERTICAL MOUNT CABLE MANAGEMENT 45 RU (ONE ON EACH SIDE AND BETWEEN EACH TWO-POST RACK).
- 3 PROVIDE STRAIGHT SECTION OF 18" WIDE LADDER TYPE CABLE RUNWAY MOUNTED AT 7'-6" A.F.F.
- 4 PROVIDE STRAIGHT SECTION OF 18" WIDE LADDER TYPE CABLE RUNWAY MOUNTED AT 8'-0" A.F.F.
- 5 PROVIDE TELECOMMUNICATION MAIN GROUNDING BUS (TMGB) AND GROUNDING AND BONDING FOR TELECOMMUNICATION RACKS AND PATHWAYS.
- 6 PROVIDE 4" EMT SLEEVE WITH POLYETHYLENE BUSHINGS THROUGH WALL ABOVE CABLE TRAY RUNWAY INTO ATTIC SPACE IN ADJACENT ROOM.
- 7 PROVIDE END MOUNTING BRACKET CABLE RUNWAY SUPPORT. TYPICAL AT EACH END. REFER TO DETAIL 12/E601. PROVIDE SIDE MOUNTING BRACKET CABLE RUNWAY SUPPORT. TYPICAL AT EACH END. REFER TO DETAIL 12/E601. PROVIDE RACK MOUNTING BRACKET CABLE RUNWAY SUPPORT. REFER TO DETAIL 12/E601. PROVIDE TRAPEZOID STYLE CABLE RUNWAY SUPPORT. REFER TO DETAIL 13/E601.
- 8 TWO 100' DIRECTIONAL HDMI CABLES D-TECH HDT-HOF70431M. DIRECTION OF CABLE INDICATED ON DRAWING.

- 9 PROVIDE TWO ACTIVE HDMI CABLES, ONE 3.5MM CABLE BETWEEN WALLPLATE AND PROJECTOR.
- 10 PROVIDE ONE HDMI CABLE BETWEEN AV PORTS.
- 11 FOUR 4" C, THREE 4" C (SPARE) - ONE 4" C WITH ONE TYPE 'FO' CABLE BETWEEN BUILDING 'B' MDF AND BUILDING 'A' IDF IN ONE 4" C.
- 12 PROVIDE RATED WALL PENETRATION 4" EMT SLEEVE WITH 4" FLAMESTOPPER FIRE STOPPING DEVICE ON BOTH ENDS OF CONDUIT.
- 13 CEILING MOUNT DATA OUTLET FOR FUTURE DISTRICT PROVIDED VAPE SENSOR.
- 14 EXTERIOR WALL MOUNT DATA OUTLET FOR FUTURE DISTRICT PROVIDED VAPE SENSOR.
- 15 CEILING MOUNT DATA AND AV OUTLETS FOR PROJECTOR. PROVIDE 4S BACKBOX WITH SINGLE GANG TRIM AND COVERPLATE WITH TWO HDMI JACKS, ONE 3.5MM AUDIO JACK, AND ONE USB JACK.
- 16 PROVIDE EXTRON PVM-220 ENCLOSURE ADJACENT TO PROJECTOR MOUNT.
- 17 PROVIDE 1-1/2" LIQUID-TIGHT FLEXIBLE METAL CONDUIT CONNECTION TO MODULAR FURNITURE WITH 6 TYPE 'D' CABLES.
- 18 PROVIDE 1-1/2" LIQUID-TIGHT FLEXIBLE METAL CONDUIT CONNECTION TO MODULAR FURNITURE WITH 4 TYPE 'D' CABLES.
- 19 THREE 100' DIRECTIONAL HDMI CABLES D-TECH HDT-HOF70431M. DIRECTION OF CABLE INDICATED ON DRAWING.

LEGEND

- T TEACHER STATION WALL PLATE: PROVIDE 4S BACKBOX WITH SINGLE GANG TRIM AND COVERPLATE AT 18" AFF. U.O.N. WITH TWO HDMI JACKS, ONE 3.5MM AUDIO JACK, AND ONE USB JACK. PROVIDE TWO 1-1/4" CONCEALED IN WALL AND STUB INTO ACCESSIBLE ATTIC SPACE ABOVE NEAREST T-BAR CEILING. U.O.N.
- P CLASSROOM SHORT-THROW PROJECTOR LOCATION: PROVIDE 4S BACKBOX WITH SINGLE GANG TRIM AND COVERPLATE AT 18" AFF. U.O.N. WITH TWO HDMI JACKS, ONE 3.5MM AUDIO JACK, AND ONE USB JACK. PROVIDE TWO 1-1/4" CONCEALED IN WALL AND STUB INTO ACCESSIBLE ATTIC SPACE ABOVE NEAREST T-BAR CEILING FROM EACH 4S BOX. U.O.N. REFER TO DETAIL 22/E600.
- AV AV INPUT: PROVIDE 4S BACKBOX WITH SINGLE GANG TRIM AND COVERPLATE AT 18" AFF. U.O.N. WITH ONE HDMI JACK. PROVIDE TWO 1-1/4" CONCEALED IN WALL AND STUB INTO ACCESSIBLE ATTIC SPACE ABOVE NEAREST T-BAR CEILING. U.O.N.
- S PROVIDE HOMERUN PA SPEAKER CABLE TO PA TERMINAL BLOCK.
- SP PROVIDE CONNECTION TO AMPLIFIER AT PROJECTOR HOUSING EXTRON 18 AWG SPEAKER CABLE.

TELECOMMUNICATION PATHWAY NOTES

- A. CONDUIT AND CABLES FOR TELECOMMUNICATION OUTLETS SHALL BE CONCEALED WITHIN WALLS AND ABOVE CEILINGS.
- B. TELECOMMUNICATION OUTLET BOXES SHALL BE 5" SQUARE BY 2-7/8" DEEP WITH A SINGLE-GANG BOX EXTENSION THAT IS MOUNTED FLUSH WITH THE FINISHED WALL.
- C. PROVIDE ONE 1" STUBBED FROM EACH TELECOMMUNICATION OUTLET BOX INTO THE ACCESSIBLE ATTIC SPACE TO FACILITATE TELECOMMUNICATION CABLE INSTALLATION.
- D. PROVIDE THREADED SET SCREW CONNECTORS WITH POLYPROPYLENE BUSHINGS AT EACH END OF CONDUIT SYSTEMS USED FOR TELECOMMUNICATION CABLE INSTALLATION. BUSHINGS SHALL BE INSTALLED AND INSPECTED PRIOR TO CABLE INSTALLATION.
- E. CABLE TRAYS SHALL COMPLY WITH NEMA VE 2 STANDARDS AND SHALL BE INSTALLED IN ACCORDANCE WITH NEMA VE 2 INSTALLATION GUIDELINES.

TELECOMMUNICATION CABLING NOTES

- A. EACH TELECOMMUNICATION CABLE SHALL BE HOMERUN FROM THE TELECOMMUNICATION OUTLET TO A PATCH PANEL LOCATED IN THE TELECOMMUNICATION ROOM.
- B. TELECOMMUNICATION CABLES SHALL BE NEATLY BUNDLED WITH VELCRO STRAPS AT 36" C.
- C. TELECOMMUNICATION CABLES SHALL BE INDEPENDENTLY SUPPORTED FROM J-HOOKS WITHIN THE ACCESSIBLE ATTIC SPACE WHERE THEY ARE NOT WITHIN CONDUIT OR SUPPORTED ON CABLE TRAY.
- D. TELECOMMUNICATION CABLES SHALL BE TERMINATED WITH MODULAR JACKS ON PATCH PANELS IN THE TELECOMMUNICATION OUTLETS AND ON MODULAR JACKS AT THE TELECOMMUNICATION OUTLETS.
- E. TELECOMMUNICATION CABLE SERVING WIRELESS ACCESS POINTS SHALL BE TERMINATED WITH PLUS TYPE CONNECTORS AT THE LOCATION OF THE WIRELESS ACCESS POINT.

SECURITY AND ACCESS ROUGH-IN NOTES

- A. SECURITY AND ACCESS SYSTEM ROUGH-IN REQUIREMENTS:
 - a. AT DOOR CONTACT LOCATIONS - DRILL 1/2" HOLE IN STRIKE SIDE OF DOOR FRAME AND THROUGH HEADER. INSTALL A PULL WIRE BETWEEN OPENING IN DOOR FRAME AND ACCESSIBLE ATTIC.
 - b. AT MOTION DETECTOR LOCATIONS - INSTALL A SINGLE-GANG OUTLET BOX WITH A SINGLE-GANG TRIM-RING IN WALL AT 84" A.F.F. INSTALL ONE 1/2" INTO ACCESSIBLE ATTIC SPACE. INSTALL A PULL WIRE BETWEEN OUTLET BOX AND ACCESSIBLE ATTIC.
 - c. AT KEYPAD LOCATIONS - INSTALL A SINGLE-GANG OUTLET BOX WITH A SINGLE-GANG TRIM-RING IN WALL AT 48" A.F.F. TO TOP OF BOX. INSTALL ONE 3/4" INTO ACCESSIBLE ATTIC SPACE. INSTALL A PULL WIRE BETWEEN OUTLET BOX AND ACCESSIBLE ATTIC.
 - d. AT CARD READER LOCATIONS - INSTALL A SINGLE-GANG OUTLET BOX WITH A SINGLE-GANG TRIM-RING IN WALL AT 48" A.F.F. TO TOP OF BOX. INSTALL ONE 3/4" INTO ACCESSIBLE ATTIC SPACE. INSTALL A PULL WIRE BETWEEN OUTLET BOX AND ACCESSIBLE ATTIC.

ONLINE SCHOOL & SPECIAL EDUCATION ADMINISTRATION DISTRICT OFFICE EXPANSION CLOVIS UNIFIED SCHOOL DISTRICT CLOVIS, CA

PROJECT NO. 12242.00

DRAWING E410

DRAWING TITLE SIGNAL PLAN - BUILDING A

TETER, INC. FRESNO HEADQUARTERS VISUAL ENGINEERING WOODSTOCK TOWN, ILLINOIS ORIGIN ARCHITECTS ENGINEERS CONNECTED

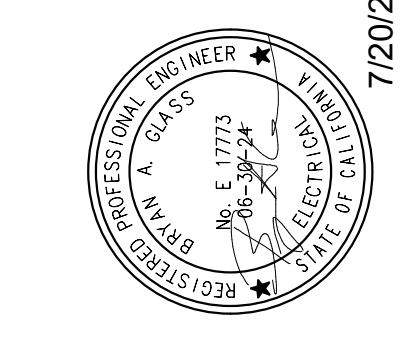

MARK	DATE	DESCRIPTION
1	10/17/23	ADDENDUM #3
2	10/25/23	ADDENDUM #5

10/16/23 DSA BACKCHECK

10/17/23 ADDENDUM #3 10/25/23 ADDENDUM #5

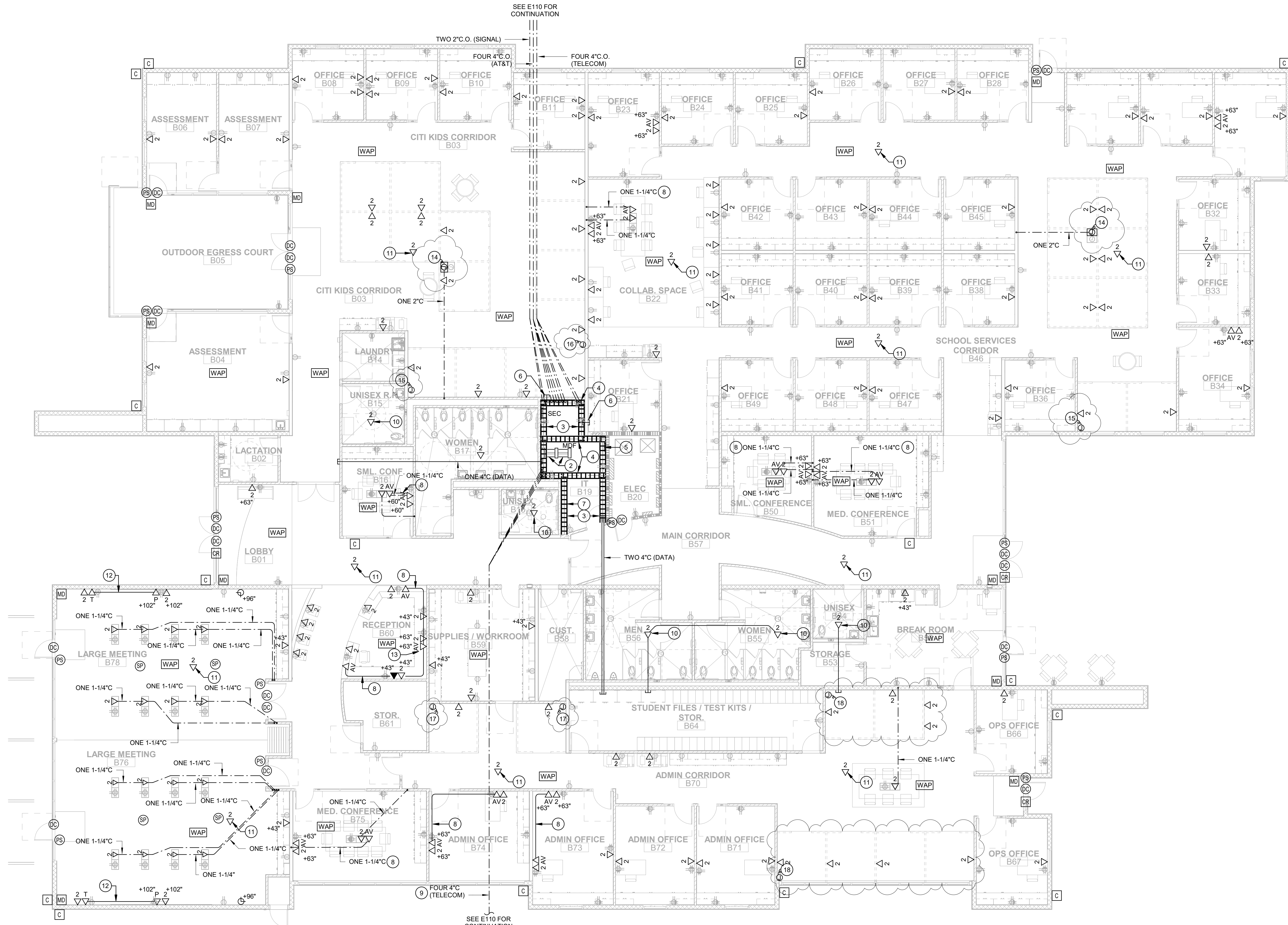

SIGNAL PLAN - BUILDING B

1/8" = 1'-0" 1

KEYNOTES

- 1 PROVIDE ONE 1-1/4" WITH ONE TYPE 'DX' CABLE FOR IRRIGATION CONTROLLER.
- 2 MDF: PROVIDE TWO 7" TALL, 19" EIA STANDARD TWO-POST RACKS. BLACK IN COLOR. CHATSWORTH PRODUCTS, INC. MODEL: 55053-703. PROVIDE LEVITON #8980L-VFR VERTICAL MOUNT CABLE MANAGEMENT (ONE ON EACH SIDE AND BETWEEN EACH TWO-POST RACK).
- 3 PROVIDE STRAIGHT SECTION OF 18" WIDE LADDER TYPE CABLE RUNWAY MOUNTED AT 7'-6" A.F.F.
- 4 PROVIDE STRAIGHT SECTION OF 18" WIDE LADDER TYPE CABLE RUNWAY MOUNTED AT 8'-0" A.F.F.
- 5 PROVIDE TELECOMMUNICATION MAIN GROUNDING BUS (TMGB) AND GROUNDING AND BONDING FOR TELECOMMUNICATION RACKS AND PATHWAYS.
- 6 PROVIDE 4" EMT SLEEVE WITH POLYETHYLENE BUSHINGS THROUGH WALL ABOVE CABLE TRAY RUNWAY INTO ATTIC SPACE IN ADJACENT ROOM.
- 7 PROVIDE END MOUNTING BRACKET CABLE RUNWAY SUPPORT, TYPICAL AT EACH END. REFER TO DETAIL 12/E601. PROVIDE SIDE MOUNTING BRACKET CABLE RUNWAY SUPPORT, TYPICAL AT EACH END. REFER TO DETAIL 12/E601. PROVIDE RACK MOUNTING BRACKET CABLE RUNWAY SUPPORT. REFER TO DETAIL 12/E601. PROVIDE TRAPEZE STYLE CABLE RUNWAY SUPPORT. REFER TO DETAIL 13/E601.

- 8 PROVIDE ONE HDMI CABLE BETWEEN AV PORTS.
- 9 FOUR 4" C, THREE 4" C (SPARE) + ONE 4" C WITH ONE TYPE 'FO' CABLE BETWEEN BUILDING 'B' MDF AND BUILDING 'A' IDF IN ONE 4" C.
- 10 CEILING MOUNT DATA OUTLET FOR FUTURE DISTRICT PROVIDED VAPE SENSOR.
- 11 CEILING MOUNT DATA OUTLET FOR FUTURE DISTRICT PROVIDED IP SPEAKER.
- 12 PROVIDE TWO ACTIVE HDMI CABLES, ONE 3.5MM CABLE, AND ONE USB CABLE BETWEEN WALLPLATE AND PROJECTOR.
- 13 PROVIDE AV FACEPLATE WITH TWO HDMI PORTS AT THIS LOCATION.
- 14 PROVIDE 2" LIQUID-TIGHT FLEXIBLE METAL CONDUIT CONNECTION TO MODULAR FURNITURE WITH 12 TYPE 'D' CABLES.
- 15 PROVIDE 1-1/2" LIQUID-TIGHT FLEXIBLE METAL CONDUIT CONNECTION TO MODULAR FURNITURE WITH 4 TYPE 'D' CABLES.
- 16 PROVIDE 1-1/2" LIQUID-TIGHT FLEXIBLE METAL CONDUIT CONNECTION TO MODULAR FURNITURE WITH 10 TYPE 'D' CABLES.
- 17 PROVIDE 1-1/2" LIQUID-TIGHT FLEXIBLE METAL CONDUIT CONNECTION TO MODULAR FURNITURE WITH 2 TYPE 'D' CABLES.
- 18 PROVIDE 1-1/2" LIQUID-TIGHT FLEXIBLE METAL CONDUIT CONNECTION TO MODULAR FURNITURE WITH 8 TYPE 'D' CABLES.

LEGEND

- T
▽ TEACHER STATION WALL PLATE: PROVIDE 4S BACKBOX WITH SINGLE GANG TRIM AND COVERPLATE AT +18" AFF. U.O.N. WITH TWO HDMI JACKS, ONE 3.5MM AUDIO JACK, AND ONE USB JACK. PROVIDE TWO 1-1/4" C CONCEALED IN WALL AND STUB INTO ACCESSIBLE ATTIC SPACE ABOVE NEAREST T-BAR CEILING, U.O.N.
- P
▽ CLASSROOM SHORT-THROW PROJECTOR LOCATION: PROVIDE 4S BACKBOX WITH SINGLE GANG TRIM AND COVERPLATE AT +18" AFF. U.O.N. WITH TWO HDMI JACKS, ONE 3.5MM AUDIO JACK, AND ONE USB JACK. PROVIDE TWO 1-1/4" C CONCEALED IN WALL AND STUB INTO ACCESSIBLE ATTIC SPACE ABOVE NEAREST T-BAR CEILING FROM EACH 4S BOX, U.O.N. REFER TO DETAIL 22/E600.
- AV
▽ AV INPUT: PROVIDE 4S BACKBOX WITH SINGLE GANG TRIM AND COVERPLATE AT +18" AFF. U.O.N. WITH ONE HDMI JACK. PROVIDE TWO 1-1/4" C CONCEALED IN WALL AND STUB INTO ACCESSIBLE ATTIC SPACE ABOVE NEAREST T-BAR CEILING, U.O.N.
- SP
○ PROVIDE CONNECTION TO AMPLIFIER AT PROJECTOR HOUSING EXTRON 18 AWG SPEAKER CABLE.

TELECOMMUNICATION PATHWAY NOTES

- A. CONDUIT AND CABLES FOR TELECOMMUNICATION OUTLETS SHALL BE CONCEALED WITHIN WALLS AND ABOVE CEILINGS.
- B. TELECOMMUNICATION OUTLET BOXES SHALL BE 5" SQUARE BY 2-7/8" DEEP WITH A SINGLE-GANG BOX EXTENSION THAT IS MOUNTED FLUSH WITH THE FINISHED WALL.
- C. PROVIDE ONE 1" STUBBED FROM EACH TELECOMMUNICATION OUTLET BOX INTO THE ACCESSIBLE ATTIC SPACE TO FACILITATE TELECOMMUNICATION CABLE INSTALLATION.
- D. PROVIDE THREADED SET SCREW CONNECTORS WITH POLYPROPYLENE BUSHINGS AT EACH END OF CONDUIT SYSTEMS USED FOR TELECOMMUNICATION CABLE INSTALLATION. BUSHINGS SHALL BE INSTALLED AND INSPECTED PRIOR TO CABLE INSTALLATION.
- E. CABLE TRAY RUNWAYS SHALL COMPLY WITH NEMA VE 1 STANDARDS AND SHALL BE INSTALLED IN ACCORDANCE WITH NEMA VE 2 INSTALLATION GUIDELINES.

TELECOMMUNICATION CABLING NOTES

- A. EACH TELECOMMUNICATION CABLE SHALL BE HOMERUN FROM THE TELECOMMUNICATION OUTLET TO A PATCH PANEL LOCATED IN THE MDF IN THE IT ROOM.
- B. TELECOMMUNICATION CABLES SHALL BE NEATLY BUNDLED WITH VELCRO STRAPS AT 30°C.
- C. TELECOMMUNICATION CABLES SHALL BE INDEPENDENTLY SUPPORTED FROM J-HOOKS WITHIN THE ACCESSIBLE ATTIC SPACE WHERE THEY ARE NOT WITHIN CONDUIT OR SUPPORTED ON CABLE TRAY.
- D. TELECOMMUNICATION CABLES SHALL BE TERMINATED WITH MODULAR JACKS ON PATCH PANELS IN THE TELECOMMUNICATION ENCLOSURE AND ON MODULAR JACKS AT THE TELECOMMUNICATION OUTLETS.
- E. TELECOMMUNICATION CABLE SERVING WIRELESS ACCESS POINTS SHALL BE TERMINATED WITH PLUG TYPE CONNECTORS AT THE LOCATION OF THE WIRELESS ACCESS POINT.

SECURITY AND ACCESS ROUGH-IN NOTES

- A. SECURITY AND ACCESS SYSTEM ROUGH-IN REQUIREMENTS:
 - a. AT DOOR CONTACT LOCATIONS - DRILL 1/2" HOLE IN STRIKE SIDE OF DOOR FRAME AND THROUGH HEADER, INSTALL A PULL WIRE BETWEEN OPENING IN DOOR FRAME AND ACCESSIBLE ATTIC.
 - b. AT MOTION DETECTOR LOCATIONS - INSTALL A SINGLE-GANG OUTLET BOX WITH A SINGLE-GANG TRIM-RING IN WALL AT 48" A.F.F. INSTALL ONE 1/2" C INTO ACCESSIBLE ATTIC SPACE. INSTALL A PULL WIRE BETWEEN OUTLET BOX AND ACCESSIBLE ATTIC.
 - c. AT KEYPAD LOCATIONS - INSTALL A SINGLE-GANG OUTLET BOX WITH A SINGLE-GANG TRIM-RING IN WALL AT 48" A.F.F. TO TOP OF BOX. INSTALL ONE 3/4" C INTO ACCESSIBLE ATTIC SPACE. INSTALL A PULL WIRE BETWEEN OUTLET BOX AND ACCESSIBLE ATTIC.
 - d. AT CARD READER LOCATIONS - INSTALL A SINGLE-GANG OUTLET BOX WITH A SINGLE-GANG TRIM-RING IN WALL AT 48" A.F.F. TO TOP OF BOX. INSTALL ONE 3/4" C INTO ACCESSIBLE ATTIC SPACE. INSTALL A PULL WIRE BETWEEN OUTLET BOX AND ACCESSIBLE ATTIC.

ONLINE SCHOOL & SPECIAL EDUCATION ADMINISTRATION DISTRICT OFFICE EXPANSION CLOVIS UNIFIED SCHOOL DISTRICT CLOVIS, CA

PROJECT NO. 12242.00 DRAWING TITLE E420

MARK	DATE	DESCRIPTION	DSA BACKCHECK
2	10/25/23	ADDENDUM #5	
	9/21/23		

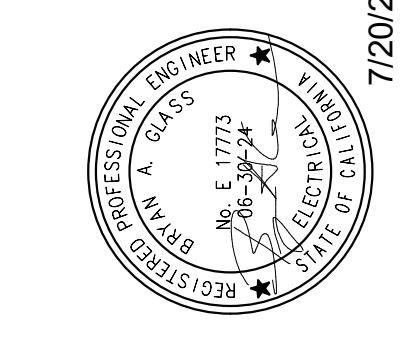

TETER, INC.
FRESNO HEADQUARTERS
VISALIA | BANGORFIELD | WOODSTOCK | SAN LUIS OBISPO
ARCHITECTS ENGINEERS CONNECTED

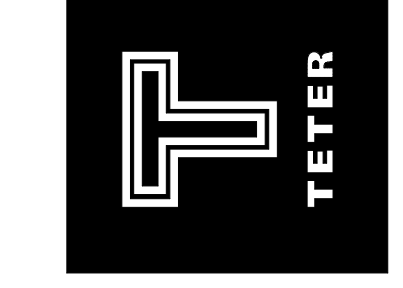

DRAWING TITLE SIGNAL PLAN - BUILDING B

THESE DOCUMENTS ARE THE PROPERTY OF TETER, INC. AND ARE NOT TO BE REPRODUCED OR TRANSMITTED IN ANY FORM OR BY ANY MEANS, ELECTRONIC OR MECHANICAL, WITHOUT THE WRITTEN PERMISSION OF TETER, INC.

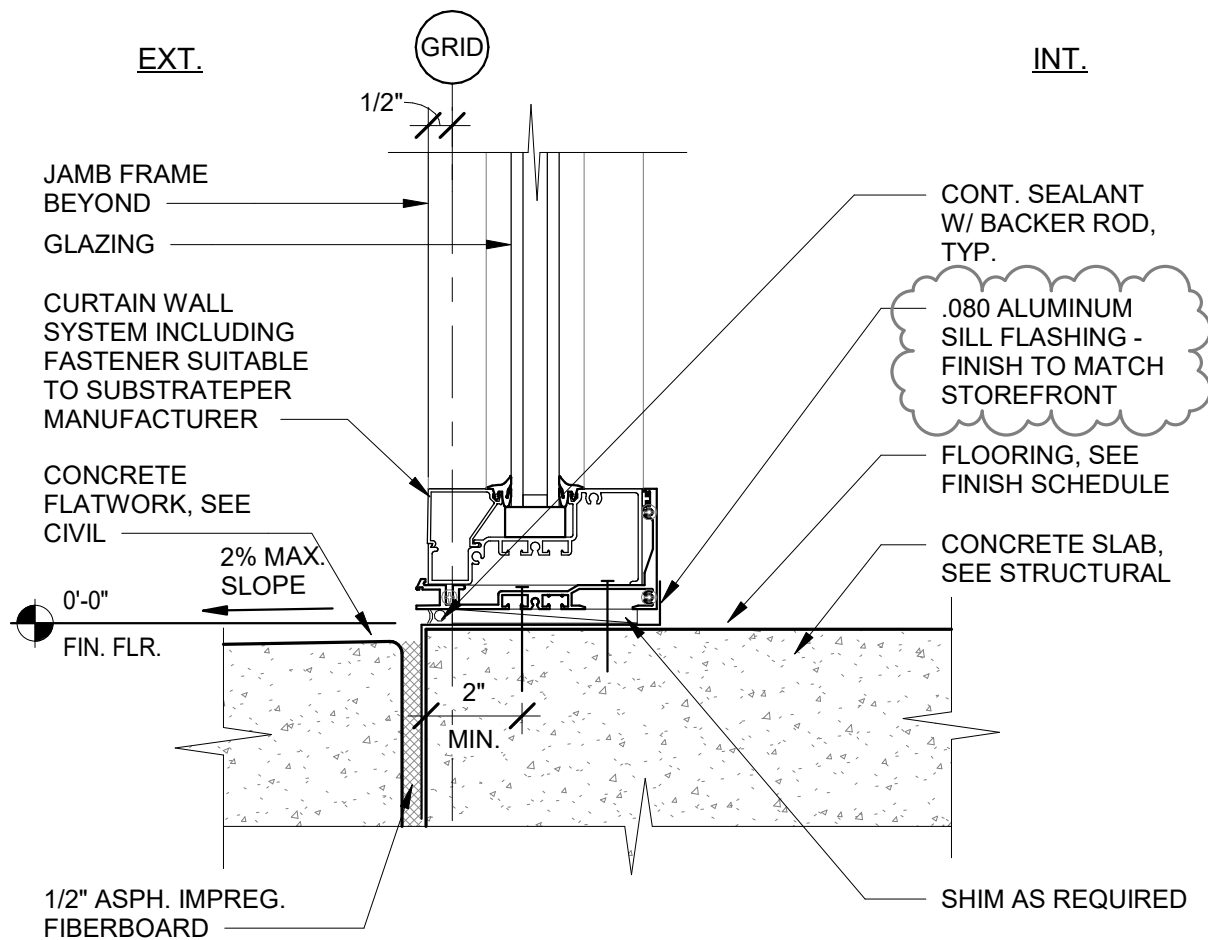

EXT. CURTAIN WALL SILL

3" = 1'-0"

REVISED DETAIL 10/A820



TETER, INC.
 FRESNO HEADQUARTERS
 VISALIA
 BAKERSFIELD
 MODESTO
 SAN LUIS OBISPO

ONLINE SCHOOL & SPECIAL EDUCATION
 ADMINISTRATION DISTRICT OFFICE EXPANSION
 CLOVIS, CA

JOB NUMBER: 12242.00
DWG. DATE: 10/24/23
AD05-A01

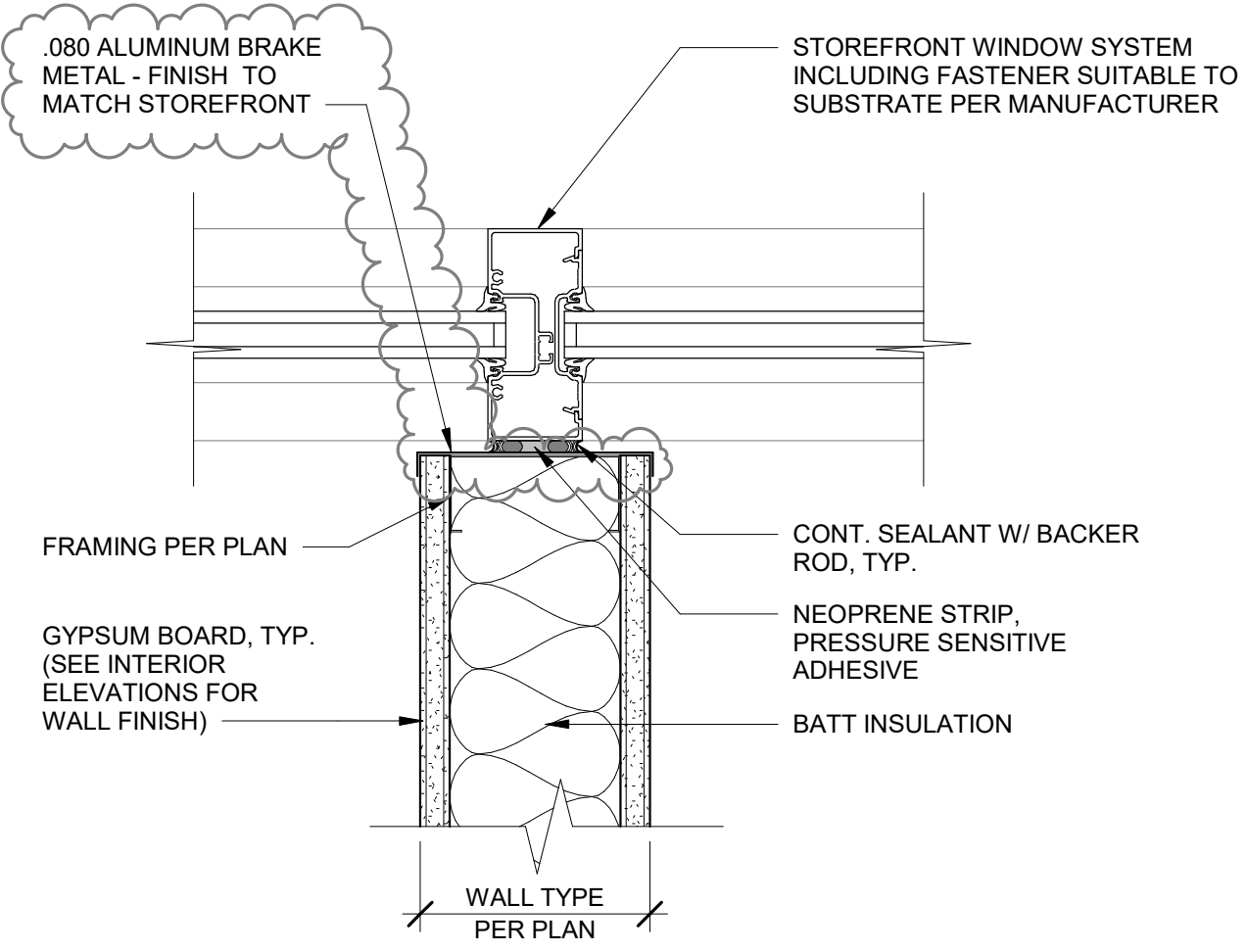

PARTITION AT WINDOW MULLION 3" = 1'-0"

REVISED
DETAIL 22/A822

	TETER, INC. FRESNO HEADQUARTERS VISALIA BAKERSFIELD MODESTO SAN LUIS OBISPO	ONLINE SCHOOL & SPECIAL EDUCATION ADMINISTRATION DISTRICT OFFICE EXPANSION CLOVIS, CA	JOB NUMBER: 12242.00
			DWG. DATE: 10/24/23
			AD05-A02

SCIENCE EQUIPMENT SCHEDULE

MARK	DESCRIPTION	MFR.	MODEL NO.	REMARKS
A1	FUME HOOD w/ STEEL BASE CABINETS	KEWAUNEE	H05	C.F.C.I
B1	FIRE BLANKET & CABINET	FLINN SCIENTIFIC	SE3006	C.F.C.I
C1	ACID/CHEMICAL STORAGE CABINET	JUSTRITE	862228; 22 GALLON, ROYAL BLUE	C.F.C.I
D1	NOT USED			

REFER TO 22/A211 - EQUIPMENT SCHEDULE



TETER

TETER, INC

7535 N. PALM AVE. 201
FRESNO, CA 93711 | 559.437.0887
125 S. BRIDGE ST. 150
VISALIA, CA 93291 | 559.625.5246
1200 DISCOVERY DR. 160
BAKERSFIELD, CA 93309 | 661.843.8400

**ONLINE SCHOOL & SPECIAL EDUCATION
ADMINISTRATION DISTRICT OFFICE EXPANSION**

CLOVIS UNIFIED SCHOOL DISTRICT

CLOVIS, CA

JOB NUMBER:
12242.00

DWG. DATE:
10.24.23

AD5-A03

SUPPLEMENTAL DRAWING

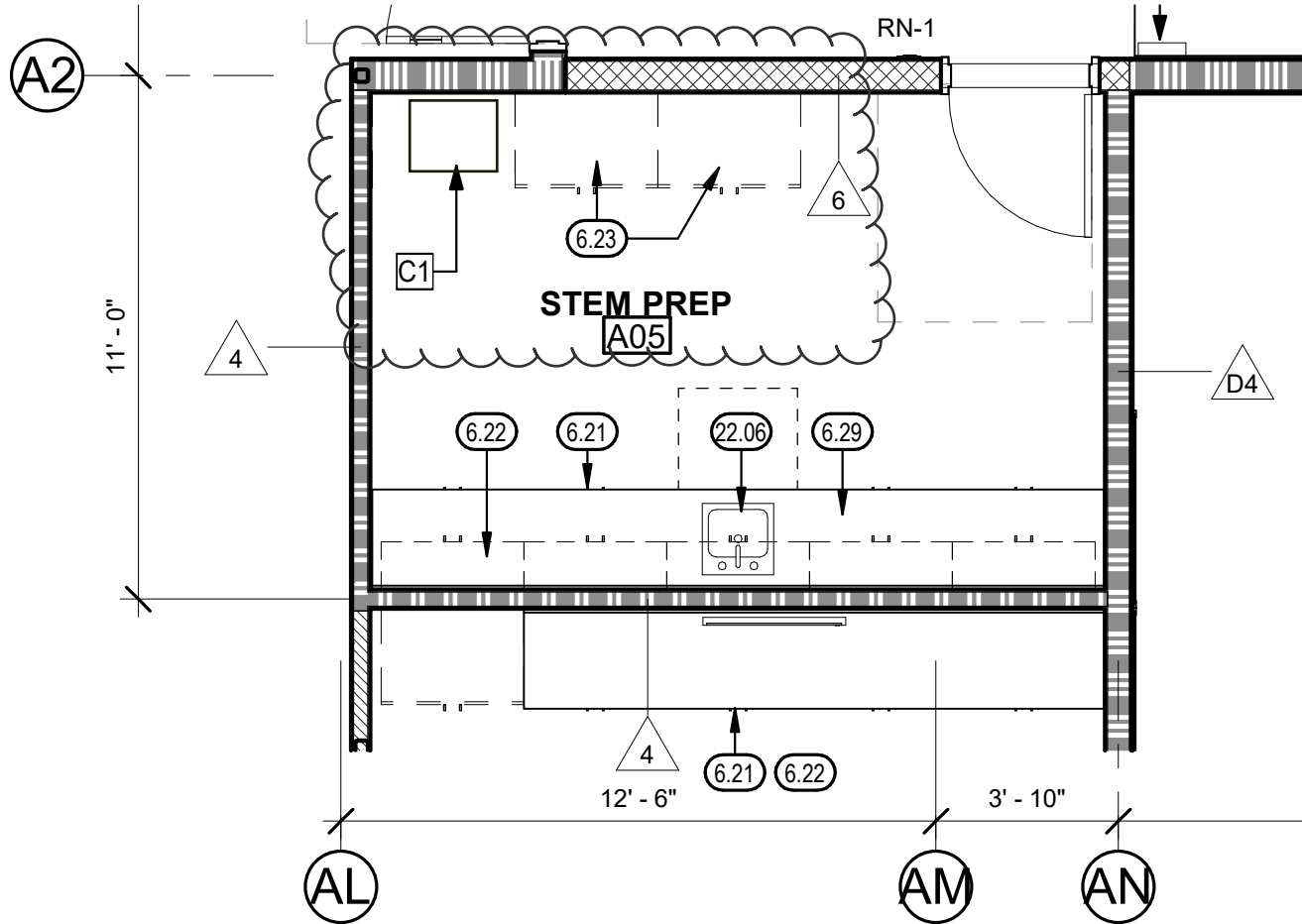

REFER TO 8/A211 - ENLARGED FLOOR PLAN - STEM A04, STEM PREP A05

1/4" = 1'-0"



NORTH



PROJECT NORTH



TETER, INC

7535 N. PALM AVE. 201
 FRESNO, CA 93711 | 559.437.0887
 125 S. BRIDGE ST. 150
 VISALIA, CA 93291 | 559.625.5246
 1200 DISCOVERY DR. 160
 BAKERSFIELD, CA 93309 | 661.843.8400

**ONLINE SCHOOL & SPECIAL EDUCATION
 ADMINISTRATION DISTRICT OFFICE EXPANSION**

CLOVIS UNIFIED SCHOOL DISTRICT

CLOVIS, CA

JOB NUMBER:
12242.00

DWG. DATE:
10.24.23

AD5-A04

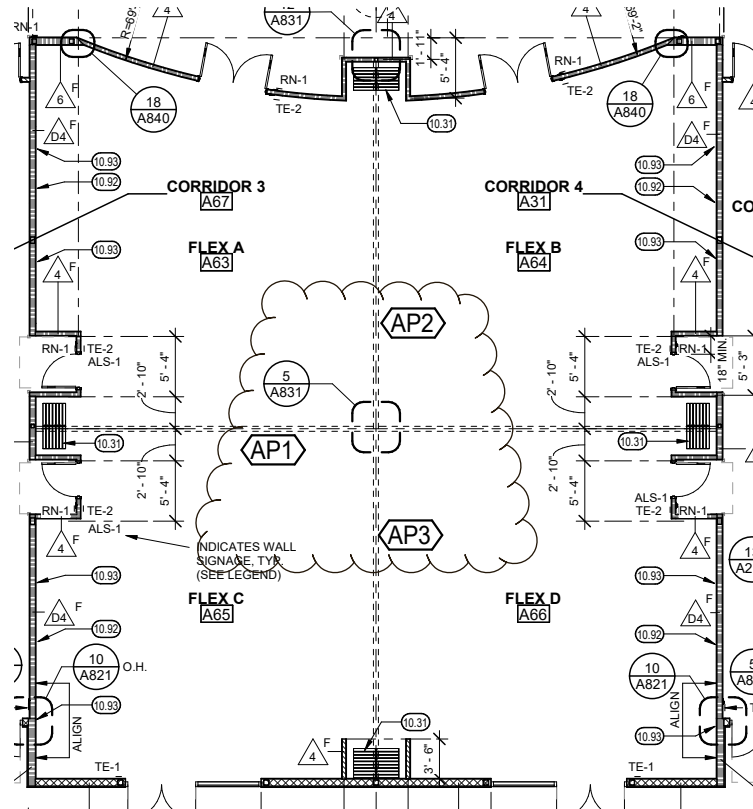

REFER TO 4/A202 - PARTIAL FLOOR PLAN - BLDG
A - ONLINE SCHOOL SOUTH

N.T.S.



NORTH



TETER, INC

7535 N. PALM AVE. 201
FRESNO, CA 93711 | 559.437.0887
125 S. BRIDGE ST. 150
VISALIA, CA 93291 | 559.625.5246
1200 DISCOVERY DR. 160
BAKERSFIELD, CA 93309 | 661.843.8400

**ONLINE SCHOOL & SPECIAL EDUCATION
ADMINISTRATION DISTRICT OFFICE EXPANSION**

CLOVIS UNIFIED SCHOOL DISTRICT

CLOVIS, CA

JOB NUMBER:
12242.00

DWG. DATE:
10.24.23

AD5-A05

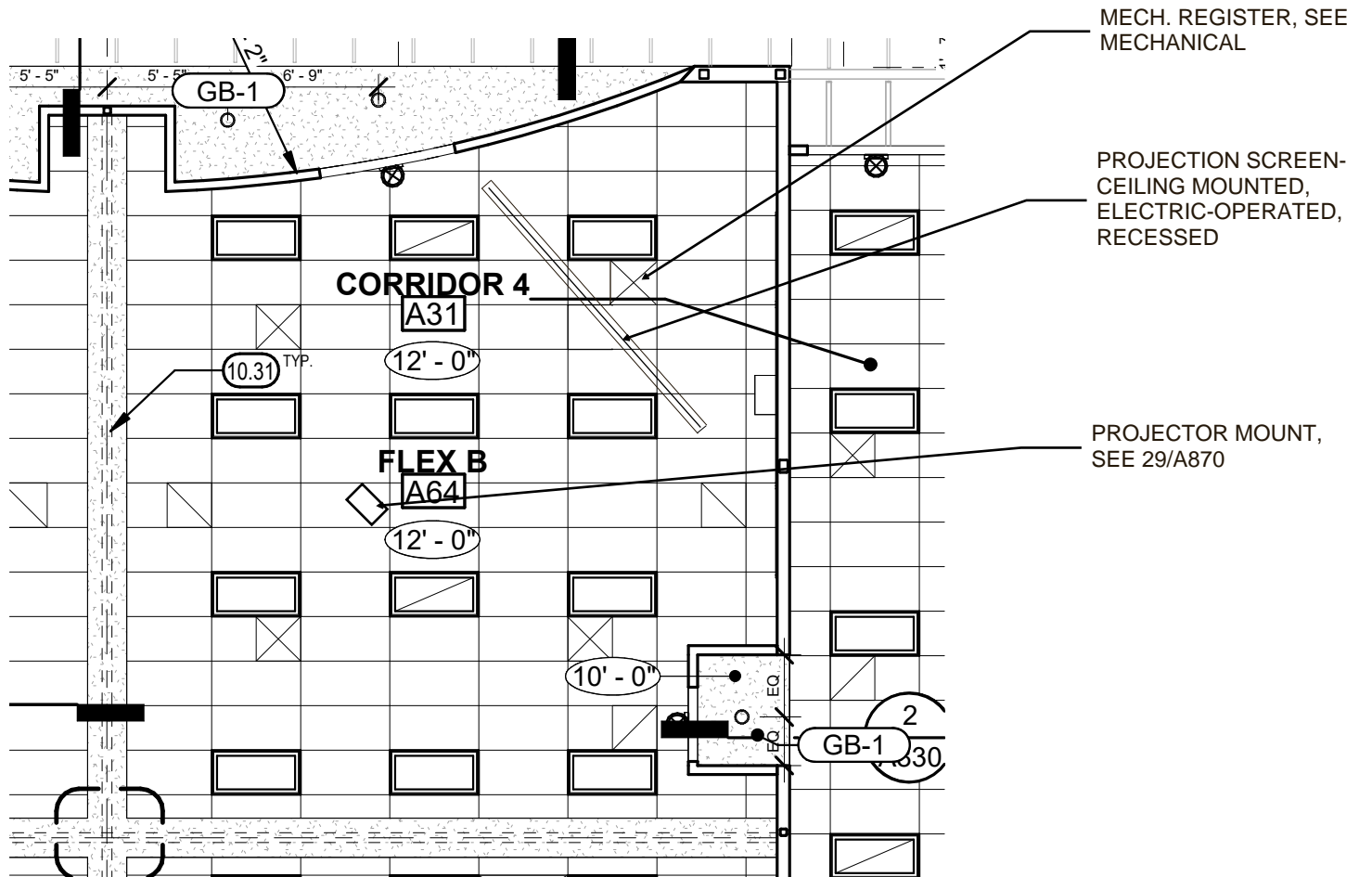

REFER TO SHEET A602 - PARTIAL REFLECTED CEILING PLAN - BLDG A - ONLINE SCHOOL SOUTH

1/8" = 1'-0"



NORTH



PROJECT NORTH



TETER, INC

7535 N. PALM AVE. 201
 FRESNO, CA 93711 | 559.437.0887
 125 S. BRIDGE ST. 150
 VISALIA, CA 93291 | 559.625.5246
 1200 DISCOVERY DR. 160
 BAKERSFIELD, CA 93309 | 661.843.8400

**ONLINE SCHOOL & SPECIAL EDUCATION
 ADMINISTRATION DISTRICT OFFICE EXPANSION**

CLOVIS UNIFIED SCHOOL DISTRICT

CLOVIS, CA

JOB NUMBER:
 12242.00

DWG. DATE:
 10.24.23

AD5-A06

ACCEPTANCE TESTING & FUNCTIONAL TESTING REQUIRMENTS

K. FUNCTIONAL PERFORMANCE TESTING			
The following acceptance tests have been identified as applicable to the project scope: ²			
02	03	04	05
System/ Equipment to be Tested	Brief description of functional performance test	Applicable Reference Appendix	Certified Acceptance Test Technician Required?
HC- A1,A2,A3,A4,A5,A6,A7,A8,A9,A10,A11,A12,A13,A14,A15,A16,A17,A18,A19,B1,B2,B3,B4,B5,B6,B7,B8,B9,B10,B11,B12,B13,B14,B15; IDU-A1,A2,B1,B2,B3	Outdoor Air	NA7.5.1 Outdoor Air	No
HC- A1,A2,A3,A4,A5,A6,A7,A8,A9,A10,A11,A12,A13,A14,A15,A16,A17,A18,A19,B1,B2,B3,B4,B5,B6,B7,B8,B9,B10,B11,B12,B13,B14,B15; IDU-A1,A2,A3,B1,B2,B3,B4,B5	Constant-Volume, Single-Zone, Air Conditioners and Heat Pumps	NA7.5.2 CV, Single Zone AC/HP	No
HC- A1,A2,A3,A4,A5,A6,A7,A8,A9,A10,A11,A12,A13,A14,A15,A16,A17,A18,A19,B1,B2,B3,B4,B5,B6,B7,B8,B9,B10,B11,B12,B13,B14,B15; IDU-A1,A2,B1,B2,B3	Air Distribution Systems	NA7.5.3 Air Distribution	No
HC- A1,A2,A3,A4,A5,A6,A7,A8,A9,A10,A11,A12,A13,A14,A15,A16,A17,A18,A19,B1,B2,B3,B4,B5,B6,B7,B8,B9,B10,B11,B12,B13,B14,B15	Air Economizer Controls	NA7.5.4 Air Economizer Controls	No
HC-A6,A7,A12,A13,A14,A15,B5,B6	Demand Control Ventilation	NA7.5.5 DCV Systems	No
HC- A1,A2,A3,A4,A5,A6,A7,A8,A9,A10,A11,A12,A13,A14,A15,A16,A17,A18,A19,B1,B2,B3,B4,B5,B6,B7,B8,B9,B10,B11,B12,B13,B14,B15; IDU-A1,A2,A3,B1,B2,B3,B4,B5	Automatic Demand Shed Control	NA7.5.10 Demand Shed (HVAC)	No

K. FUNCTIONAL PERFORMANCE TESTING			
HC- A1,A2,A3,A4,A5,A6,A7,A8,A9,A10,A11,A12,A13,A14,A15,A16,A17,A18,A19,B1,B2,B3,B4,B5,B6,B7,B8,B9,B10,B11,B12,B13,B14,B15	Fault Detection and Diagnostics (FDD) for Packaged Direct-Expansion Units	NA7.5.11 FDD for Package DX	No
The acceptance tests required by Title 24, Part 6 outline the minimum functional performance testing scope to be conducted for compliance. However, the commissioning scope may include additional functional performance tests on systems or equipment not having acceptance tests required by Title 24 Part 6.			
The following additional functional performance tests have been requested by the owner or owner's representative:			

06	07
System/ Equipment to be Tested	Brief description of functional performance test
HC- A1,A2,A3,A4,A5,A6,A7,A8,A9,A10,A11,A12,A13,A14,A15,A16,A17,A18,A19,B1,B2,B3,B4,B5,B6,B7,B8,B9,B10,B11,B12,B13,B14,B15; IDU-A1,A2,B1,B2,B3	Outdoor Air
HC- A1,A2,A3,A4,A5,A6,A7,A8,A9,A10,A11,A12,A13,A14,A15,A16,A17,A18,A19,B1,B2,B3,B4,B5,B6,B7,B8,B9,B10,B11,B12,B13,B14,B15; IDU-A1,A2,A3,B1,B2,B3,B4,B5	Constant-Volume, Single-Zone, Air Conditioners and Heat Pumps
HC- A1,A2,A3,A4,A5,A6,A7,A8,A9,A10,A11,A12,A13,A14,A15,A16,A17,A18,A19,B1,B2,B3,B4,B5,B6,B7,B8,B9,B10,B11,B12,B13,B14,B15; IDU-A1,A2,B1,B2,B3	Air Distribution Systems
HC- A1,A2,A3,A4,A5,A6,A7,A8,A9,A10,A11,A12,A13,A14,A15,A16,A17,A18,A19,B1,B2,B3,B4,B5,B6,B7,B8,B9,B10,B11,B12,B13,B14,B15	Air Economizer Controls
HC-A6,A7,A12,A13,A14,A15,B5,B6	Demand Control Ventilation

K. FUNCTIONAL PERFORMANCE TESTING	
HC- A1,A2,A3,A4,A5,A6,A7,A8,A9,A10,A11,A12,A13,A14,A15,A16,A17,A18,A19,B1,B2,B3,B4,B5,B6,B7,B8,B9,B10,B11,B12,B13,B14,B15; IDU-A1,A2,A3,B1,B2,B3,B4,B5	Automatic Demand Shed Control
HC- A1,A2,A3,A4,A5,A6,A7,A8,A9,A10,A11,A12,A13,A14,A15,A16,A17,A18,A19,B1,B2,B3,B4,B5,B6,B7,B8,B9,B10,B11,B12,B13,B14,B15	Fault Detection and Diagnostics (FDD) for Packaged Direct-Expansion Units

¹FOOTNOTE: See the signature block on the last page of this compliance document for the responsible party.

²Required acceptance tests can be determined by reviewing the "Certificates of Acceptance" table on each Certificate of Compliance submitted for permit application.